

# Spin polarization amplification within nonmagnetic semiconductors at room temperature

Soon-Wook Jung and Hyun-Woo Lee

Department of Physics, Pohang University of Science  
and Technology, Pohang, Kyungbuk 790-784, Korea

(Dated: June 16, 2021)

## Abstract

We demonstrate theoretically that the spin polarization of current can be electrically amplified within nonmagnetic semiconductors by exploiting the fact the spin current, compared to the charge current, is weakly perturbed by electric driving forces. As a specific example, we consider a T-shaped current branching geometry made entirely of a nonmagnetic semiconductor, where the current is injected into one of the branches (input branch) and splits into the other two branches (output branches). We show that when the input current has a moderate spin polarization, the spin polarization in one of the output branches can be higher than the spin polarization in the input branch and may reach 100% when the relative magnitudes of current-driving electric fields in the two output branches are properly tuned. The proposed amplification scheme does not use ferromagnets or magnetic fields, and does not require low temperature operation, providing an efficient way to generate a highly spin polarized current in nonmagnetic semiconductors at room temperature.

PACS numbers: 72.25.Hg, 72.25.Dc

One of the major challenges of the spintronics is to electrically generate a highly spin polarized current in a nonmagnetic semiconductor at room temperature [1, 2, 3]. High spin polarization (SP) of 40–90% has been reported [4, 5, 6, 7, 8] in electrical spin injection from a magnetic semiconductor to a nonmagnetic semiconductor but those reports are yet limited to low temperatures since the performance of a magnetic semiconductor as a spin aligner degrades considerably at room temperature. On the other hand, in electrical spin injection from a conventional metallic ferromagnet to a nonmagnetic semiconductor, the temperature dependence is expected to be weaker since the Curie temperatures of many ferromagnets are higher than the room temperature. In this case, however, the conductivity mismatch [9] between a ferromagnet and a nonmagnetic semiconductor suppresses the SP of current [10] below 1% as the current passes the heterojunction interface between a ferromagnet and a nonmagnetic semiconductor. It has been proposed [11, 12, 13] that the conductivity mismatch problem can be resolved by introducing a thin tunnel barrier at the heterojunction interface. Subsequent experiments [14, 15] using oxide tunnel barriers indeed found enhanced SP of 15–30% at room temperature. Schottky tunnel barriers are also demonstrated to be effective and the SP of 2–30% have been reported [16, 17] at low temperatures. Though these results are already encouraging demonstrations of the electrical spin injection into nonmagnetic semiconductors, further enhancement is desired for practical semiconductor spintronic applications. In order to achieve a higher SP at room temperature, effects of the heterojunction interface on the SP needs clarification. There are indications [18, 19] that the SP is affected not only by the height and width of the tunnelling barrier but also by electronic structure of the heterojunction interface.

In this paper, we do not address the issue of the interfacial effects on the SP. Instead we present a method complementary to the electrical spin injection; namely a method to electrically amplify, within nonmagnetic semiconductors, the SP of the injected current. Given spin-up current density  $j^{\uparrow}$  and spin-down current density  $j^{\downarrow}$ , the SP is defined as  $(j^{\uparrow} - j^{\downarrow}) / (j^{\uparrow} + j^{\downarrow}) = j^s / J$ , where  $j^s = j^{\uparrow} - j^{\downarrow}$  is the spin current and  $J = j^{\uparrow} + j^{\downarrow}$  is the charge current. For the SP amplification, we exploit the fact that the spin current  $j^s$  is less affected by the electrical driving forces than the charge current  $J$  is. One of simple ways to exploit this is to use a three-terminal T-shaped current branching geometry (Fig. 1) made entirely of a nonmagnetic semiconductor. When a charge current  $J_{in}$  with the SP  $_{in} < 1$  is injected to the input branch (branch 0), we demonstrate below that the resulting SP profile within the

current branching geometry does depend on the relative magnitude of the current-driving electric fields in the two output branches and that the SP in one of the output branches can be higher than  $j_{in}$ , illustrating the possibility of the electrical SP amplification. The proposed scheme does not need ferromagnets, magnetic fields, or any heterojunction interfaces, and it does not require a low temperature operation. Combined with moderate the SP achieved via electrical spin injection from a conventional metallic ferromagnet [14, 15], the proposed amplification scheme provides an efficient tool to generate a highly spin polarized current in a nonmagnetic semiconductor at room temperature. Recently Kato et al. have reported the observation of electrical spin control in strained semiconductors using the spin-orbit coupling via strain-induced field [20]. In contrast, our spin amplification scheme does not require the application of the strain.

To illustrate our proposal, we use the drift-diffusion model of electron transport in diffusive semiconductors formulated by Yu and Flatté [21]. The spin-resolved current densities  $j^{\uparrow}(x;t)$  and  $j^{\downarrow}(x;t)$  can be written as

$$j^{\uparrow} = \sigma^{\uparrow} E + eD \nabla_x n^{\uparrow}; \quad (1a)$$

$$j^{\downarrow} = \sigma^{\downarrow} E + eD \nabla_x n^{\downarrow}; \quad (1b)$$

where  $e (< 0)$  is the electron charge,  $D$  is the diffusion constant, and  $E$  is the electric field. Here  $\sigma^{(\#)}$  is the spin-up (spin-down) conductivity, which depends on the electron density via  $\sigma^{(\#)} = \sigma_s/2 + e n^{(\#)}$  where  $n^{(\#)}$  is the spin-up (spin-down) electron density deviation from its equilibrium value  $n_s/2$ , and  $\sigma_s$  is the total conductivity in equilibrium. Here the mobility  $\mu$  is a constant independent of  $E$  and  $n^{(\#)}$ , and related to  $D$  via  $\mu = eD/k_B T$  for non-degenerate semiconductors [22].

According to Yu and Flatté [22], a steady state density profile for a non-degenerate n-doped semiconductor satisfies

$$n^{\uparrow} + n^{\downarrow} = 0; \quad (2a)$$

$$\nabla_x^2 (n^{\uparrow} - n^{\downarrow}) + \frac{eE}{k_B T} \nabla_x (n^{\uparrow} - n^{\downarrow}) - \frac{(n^{\uparrow} - n^{\downarrow})}{L_s^2} = 0; \quad (2b)$$

where  $k_B$  is the Boltzmann constant,  $T$  is the temperature, and  $L_s$  is the equilibrium spin relaxation length. The spin resolved electrochemical potentials  $\mu^{(\#)}$  in a semiconductor are related [22] to the spin density  $n^{(\#)}$  via

$$\mu^{(\#)} = k_B T \ln [1 + 2n^{(\#)} - n_s] + eE x + C; \quad (3)$$

where  $C$  is a constant. The charge neutrality condition Eq. (2a) leads to

$$J = -eE; \quad (4a)$$

$$j = eD \nabla (n - n^\#) + eE (n - n^\#); \quad (4b)$$

To get an insight into the electrical SP amplification, it is useful to first consider briefly the weak electric field limit,  $j \ll E_c$ ,  $D = L_s = k_B T / eE_s$ , where Eqs. (2b) and (4b) are simplified to

$$\nabla^2 (n - n^\#) = \frac{(n - n^\#)}{L_s^2}; \quad (5a)$$

$$j = eD \nabla (n - n^\#); \quad (5b)$$

Note that in this limit the spin current  $j$  (and spin density  $n - n^\#$ ) is decoupled from the electric field and governed by diffusion process, while the charge current  $J$  is governed by the electric field [Eq. (4a)]. Recalling that the SP  $\propto j=J$ , this difference in the coupling strengths of the charge current and spin current to the electric field opens up the possibility of the SP amplification via the electric field modulation within a semiconductor. In a conventional two-terminal geometry, however, this possibility cannot be exploited since the charge conservation fixes the electric field [Eq. (4a)] once the magnitude of the injected current is fixed and thus the electric field modulation is not possible. In the current branching geometry in Fig. 1, in contrast, a given injected current  $J_{in}$  is branched into  $J_1$  and  $J_2$ . Since the charge conservation requires only the total current conservation  $J_1 + J_2 = J_{in}$ , the electric field in, say, the branch 1 can be modulated and this degree of freedom can be exploited to amplify the SP in the branch 1 [See Eq. (15)].

Next we consider general  $E$  and apply the drift-diffusion model to the T-shaped current branching geometry (Fig. 1) made of an n-doped diffusive nonmagnetic semiconductor. The charge current  $J_{in}$  with the SP  $\psi_{in}$  is injected into the branch 0 ( $0 < x_0 < l$ ) and flows to the branch 1 ( $x_1 > 0$ ) and 2 ( $x_2 > 0$ ) with the branched current  $J_1$  and  $J_2$ , respectively. Note that the charge currents  $J_i$  and the electric field  $E_i$  ( $i = 0; 1; 2$ ) are constants within each branch  $i$  in the steady state. Taking the coordinates in the branch  $i$  to be positive  $x_i$  (inset in Fig. 1),  $J_i$  in our convention is positive (negative) when the current is flowing outward (inward) from (towards) the branching point,  $x_0 = x_1 = x_2 = 0$ . Note that  $J_0 = -J_{in}$  in this convention. To be specific, we consider below the electron injection into the branch 0.

Thus  $J_{in} < 0$  and  $J_0 = -J_{in} > 0$ . And the direction of the electric field is parallel to the  $x_0$ -axis in the branch 0 ( $E_0 = E_0 \hat{x}_0, E_0 > 0$ ), and antiparallel to the  $x_{1(2)}$ -axis in the branch 1(2) ( $E_{1(2)} = -E_{1(2)} \hat{x}_{1(2)}, E_{1(2)} > 0$ ).

The charge current conservation leads to  $J_0 = -(J_1 + J_2)$ . Defining the branching ratios  $\alpha_1 = J_1/J_{in}$  and  $\alpha_2 = J_2/J_{in}$ , we impose the branching conditions,

$$\alpha_1 + \alpha_2 = 1 \quad \text{and} \quad 0 \leq \alpha_i \leq 1; \quad (6)$$

Due to Eq. (2), the electron density  $n_i^{e\#}$  in the branch  $i$  becomes

$$n_0^{e\#}(x_0) = A_0 e^{x_0=L_{d0}} + B_0 e^{-x_0=L_{u0}}; \quad (7a)$$

$$n_1^{e\#}(x_1) = A_1 e^{x_1=L_{u1}} + B_1 e^{-x_1=L_{d1}}; \quad (7b)$$

$$n_2^{e\#}(x_2) = A_2 e^{x_2=L_{u2}} + B_2 e^{-x_2=L_{d2}}; \quad (7c)$$

and the electrochemical potential  $\mu_i^{e\#}$  becomes

$$\mu_0^{e\#} = k_B T \ln [1 + 2n_0^{e\#}/n_s] + eE_0 x_0 + C_0; \quad (8a)$$

$$\mu_1^{e\#} = k_B T \ln [1 + 2n_1^{e\#}/n_s] - eE_1 x_1 + C_1; \quad (8b)$$

$$\mu_2^{e\#} = k_B T \ln [1 + 2n_2^{e\#}/n_s] - eE_2 x_2 + C_2; \quad (8c)$$

where  $L_{ui} = L_s = \lambda_{ui}$  and  $L_{di} = L_s = \lambda_{di}$  are the up-stream and down-stream spin diffusion lengths, respectively [22], with  $L_{ui}L_{di} = L_s^2$ . Here  $\lambda_{ui}$  and  $\lambda_{di}$  are given by

$$\lambda_{di} = \frac{1}{2} \frac{E_i}{E_c} + \frac{1}{2} \frac{E_i^2}{E_c^2} + 1; \quad (9a)$$

$$\lambda_{ui} = \frac{1}{2} \frac{E_i}{E_c} + \frac{1}{2} \frac{E_i^2}{E_c^2} + 1; \quad (9b)$$

Note that  $L_{di} > L_s > L_{ui}$  since  $E_i > 0$  is assumed. On the other hand, when electrons are extracted from the branch 0 and  $E_i < 0$ , Eqs. (7)–(9) remain the same but  $L_{di} < L_s < L_{ui}$ . Here we have assumed that the thickness of each branch is much smaller than the spin relaxation length, so that the system is essentially one-dimensional. For simplicity, we also assume that the cross sections of all three branches are the same. Then  $E_0 = E_1 + E_2$ . Determination of the coefficients  $A_i$ ,  $B_i$ , and  $C_i$  requires the boundary conditions at the branching point ( $x_0 = x_1 = x_2 = 0$ ) and at the end points of the branches ( $x_0 = l; x_1 = 1; x_2 = 1$ ). When the three branches make an ohmic contact with each other (in this

case the contact is not spin-selective), the spin-resolved electrochemical potentials  $\mu_{\sigma}^{\#}$  are continuous

$$\mu_{\sigma}^{\#}(x_0 = 0) = \mu_{\sigma}^{\#}(x_1 = 0) = \mu_{\sigma}^{\#}(x_2 = 0); \quad (10)$$

and the spin currents are conserved

$$j_0(x_0 = 0) + j_1(x_1 = 0) + j_2(x_2 = 0) = 0; \quad (11)$$

at the branching point. At the end point of the branch 0,

$$j_0(x_0 = l) = j_{in} J_0; \quad (12)$$

and at the end points of the output branches ( $i=1, 2$ ), the finiteness of the spin relaxation length imposes,

$$j_i^{\#}(x_i = l) = j_i^{\#}(x_i = 0) = 0; \quad (13)$$

Without loss of generality, we may set  $C_1 = 0$ . Then the remaining 8 coefficient are fixed by the 8 constraints from Eqs. (10)–(13). After some algebra we obtain the SP  $j_1(x_1) = j_i(x_i) = J_i$ . For example,  $j_1(x_1)$  is given by

$$j_1(x_1) = \frac{j_{in} [(J_{in} - J_c) (u_0 + d_1) e^{x_1=L_{d1}}]}{[(J_{in} - J_c) (u_0 + d_1 + d_2) e^{d_0} + (J_{in} + J_c) (d_0 - d_1 - d_2) e^{-u_0}]}; \quad (14)$$

where  $l=L_s$  and  $J_c = \frac{1}{2} E_c$ . This equation is the main result of this paper.

To understand implications of Eq. (14), we first examine the small injection current limit,  $j_{in} \ll J_c$ , which is equivalent to the weak electric field limit addressed briefly above. In this limit, Eq. (14) is simplified to

$$j_1(x_1) = \frac{j_{in} \exp(-x_1=L_s)}{\sinh(l=L_s) + 2 \cosh(l=L_s)}; \quad (15)$$

Note that  $j_1(x_1)$  becomes larger than  $j_{in}$  for sufficiently small  $j_1 = J_1 = J_{in} = E_1 = E_0$  or for sufficiently small  $E_1$ . Thus a proper tuning of the electric field  $E_1$  in the output branch 1 indeed accomplishes the SP amplification. For  $x_1 \ll l = L_s$ , the SP amplification occurs for  $j_1 < j_{in} = 2$  or  $E_1 < E_0 = 2$ . In particular when  $E_1$  is tuned so that  $j_1 = j_{in}$ , where

$$j_{in} = \frac{j_{in}}{\sinh(l=L_s) + 2 \cosh(l=L_s)}; \quad (16)$$

the SP in the branch 1 becomes 100% at  $x_1 = 0$  and remains close to 100% over the length segment of order  $L_s$  in the branch 1. The magnitude of the 100% spin polarized current is given by  $j_1 J_{in}$ , which becomes  $j_1 J_{in} = 2$  when  $l = L_s$ . Here the factor 2 is due to the branching of the spin current into the two output branches. The expression for  $j_1^{n\#}$  in the weak field limit is illustrative;

$$j_1^{n\#}(x_1) = \frac{1}{2} E_1 \frac{1}{2 \sinh(l=L_s) + 2 \cosh(l=L_s)} : \quad (17)$$

Note that the spin current  $j_1 = j_1^n + j_1^\#$  is independent of  $E_1$  while the charge current  $J_1 = j_1^n + j_1^\#$  is directly proportional to  $E_1$ , thus enabling the SP amplification by the electric field. We remark that Eqs. (15) and (17) can be obtained also by using the diffusion equation [9, 13, 23]  $\nabla^2(\psi^n + \psi^\#) = \alpha x^2 - (\psi^n + \psi^\#) = L_s^2 = 0$ , which is used to describe highly degenerated metal systems.

Figure 2 shows the SP  $j_1$  in the branch 1 for various  $E_0$  as a function of the branching ratio  $\beta_1 = J_1/J_{in} = E_1/E_0$ . For the plots,  $j_{in} = 0.16$ ,  $x_1 = 0.3L_s$ , and  $l = 0.3L_s$  are used. Note that  $\beta_1(x_1 = 0.3L_s)$  is higher than  $j_{in}$  (horizontal solid lines in Fig. 2) when  $\beta_1$  is smaller than a critical value that depends on  $E_0$ , and reaches 1 when  $\beta_1$  is reduced further. The SP amplification for small  $\beta_1$  (or small  $J_1$ ) is most effective for small and moderate injection current  $J_{in}$  (or for  $J_0 < E_c$ ) and becomes less effective in the high injection current limit (or for  $J_0 > E_c$ ). But even for  $J_0 > E_c$ , the SP amplification is still possible provided that the branching ratio  $\beta_1$  is sufficiently small so that  $E_1 < E_c$ . For  $J_0 > E_c$ ,  $J_1 > E_c$ , and  $l = L_s$ , Eq. (14) reduces to  $j_1(x_1) = j_{in} (J_c = j_1 J_{in}) \exp(-x_1/L_s)$  for  $J_{in} < 0$  (electron injection into the branch 0) and to  $j_1(x_1) = j_{in} (J_{in} = j_1 J_c) \exp[-x_1/L_s + (l=L_s)(J_{in}=J_c)l]$  for  $J_{in} > 0$  (electron extraction from the branch 0), which can be large than  $j_{in}$  for sufficiently small  $\beta_1$ . The dependence on the sign of  $J_{in}$  arises since not only the charge current but also the spin current is coupled to the electric field in the strong electric field limit. The coupling between the spin current and the electric field arises from the drift terms [second term in Eq. (2b) and the last term in Eq. (4b)], and makes the relaxation of the spin current dependent on the electric field direction [22].

Next we estimate the field strength  $E_1$  for the SP amplification in real semiconductors at room temperature. For a nondegenerate n-doped nonmagnetic semiconductor [13, 24] with the doping density  $n_s = 10^{16} \text{ cm}^{-3}$ , the mobility  $\mu = 5400 \text{ cm}^2/\text{Vs}$ , and the equilibrium spin diffusion length  $L_s = 1.83 \text{ } \mu\text{m}$ , one finds  $E_c = 141 \text{ V/cm}$  at 300K and  $J_c = 1220 \text{ A/cm}^2$ . For

$E_0 = E_c$  and  $l = 0.3L_s$ , the  $SP_{-1}$  at  $x_1 = 0.3L_s$  is larger than  $\gamma_{in}$  for  $E_1 < 0.31E_c$  ( $44V = cm$ ) and than  $5 \gamma_{in}$  for  $E_1 < 0.046E_c$  ( $6.5V = cm$ ).

Lastly we comment on several prior proposals to generate highly spin polarized current by using multiple-terminal structures [25, 26, 27, 28, 29, 30]. Though the proposed structures are similar to Fig. 1 in the sense that they all use structures with multiple terminals, there are notable differences; The three-terminal structure in Ref. 25 includes two ferromagnetic electrodes and three heterojunction interfaces. The three-terminal structures in Refs. 26 and 27 use the Coulomb blockade effect in quantum dots, which limits their operation to low temperatures. The three-terminal structure in Ref. 28 contains a superconducting electrode, which again limits its operation to low temperatures. The ballistic three-terminal structures in Ref. 29 exploit the Rashba spin-orbit coupling [30] in a two-dimensional electron gas to generate a highly spin polarized current. When parameters for InAs/InGaAs heterostructures are used, it turns out that the operation of this mechanism is limited to a rather narrow energy range, whose width is an order of magnitude smaller than the thermal energy at the room temperature. It is also demonstrated [31] that this mechanism becomes ineffective in the diffusive regime.

In summary, we have demonstrated that the spin polarization can be electrically amplified within a nonmagnetic semiconductor by using a current branching geometry. The proposed amplification scheme does not require a ferromagnet, a magnetic field, or a low temperature operation, and is thus expected to be an efficient method to generate a highly spin polarized current in a nonmagnetic semiconductor at room temperature.

We thank Hu-Jong Lee and Jae-Hoon Park for valuable comments. This work was supported by the SRC/ERC program (Grant No. R11-2000-071) and the Basic Research Program (Grant No. R01-2005-000-10352-0) of MOST/KOSEF and by the Korea Research Foundation Grant (Grant No. KRF-2005-070-C00055) funded by the Korean Government (MOEHRD).

---

[1] G. A. Prinz, *Science* 282, 1660 (1998).

[2] S. A. Wolf, D. D. Awschalom, R. A. Buhrman, J. M. Doughton, S. von Mönch, M. L. Roukes, A. Y. Chtchelkanova, and D. M. Treger, *Science* 294, 1488 (2001).



- [3] I. Zutic, J. Fabian, and S. D. Sarma, *Rev. Mod. Phys.* 76, 323 (2004).
- [4] R. Fiederling, M. Keim, G. Reuscher, W. Ossau, G. Schmidt, A. Waag, and L. W. Molenkamp, *Nature* 402, 787 (1999).
- [5] B. T. Jonker, Y. D. Park, B. R. Bennett, H. D. Cheong, G. Kiøseoglu, and A. Petrou, *Phys. Rev. B* 62, 8180 (2000).
- [6] Y. D. Park, B. T. Jonker, B. R. Bennett, G. Itskos, M. Furis, G. Kiøseoglu, and A. Petrou *Appl. Phys. Lett.* 77, 3989 (2000).
- [7] B. T. Jonker, A. T. Hanbicki, Y. D. Park, G. Itskos, M. Furis, G. Kiøseoglu, A. Petrou, and X. Wei, *Appl. Phys. Lett.* 79, 3098 (2001).
- [8] P. Van Dorpe, Z. Liu, W. Van Roy, V. F. M. Otsnyi, M. Sawicki, G. Borghs, and J. De Boeck, *Appl. Phys. Lett.* 84, 3495 (2004).
- [9] G. Schmidt, D. Ferrand, L. W. Molenkamp, A. T. Filip, and B. J. van Wees, *Phys. Rev. B* 62, R4790 (2000).
- [10] A. T. Filip, B. H. Hoving, F. J. Jedema, B. J. van Wees, B. Dutta, and S. Borghs, *Phys. Rev. B* 62, 9996 (2000).
- [11] E. I. Rashba, *Phys. Rev. B* 62, R16267 (2000).
- [12] D. L. Smith and R. N. Silver, *Phys. Rev. B* 64, 045323 (2001).
- [13] A. Fert and H. Jaes, *Phys. Rev. B* 64, 184420 (2001).
- [14] V. F. M. Otsnyi, P. Van Dorpe, W. Van Roy, E. G. Oovaerts, V. I. Safarov, G. Borghs, and J. De Boeck, *Phys. Rev. B* 68, 245319 (2003).
- [15] X. Jiang, R. Wang, R. M. Shelby, R. M. Macfarlane, S. R. Bank, J. S. Harris, and S. S. P. Parkin, *Phys. Rev. Lett.* 94, 056601 (2005).
- [16] H. J. Zhu, M. Ramsteiner, H. Kostial, M. W. Assenauer, H.-P. Schönherr, and K. H. Ploog, *Phys. Rev. Lett.* 87, 016601 (2001).
- [17] A. T. Hanbicki, O. M. J. van 't Erve, R. M.agno, G. Kiøseoglu, C. H. Li, B. T. Jonker, G. Itskos, R. Mallory, M. Yasar, and A. Petrou, *Appl. Phys. Lett.* 82, 4092 (2003).
- [18] J. M. De Teresa, A. Barthelémy, A. Fert, J. P. Contour, F. Montaigne, and P. Seneor, *Science* 286, 507 (1999).
- [19] W. H. Butler, X.-G. Zhang, T. C. Schulthess, and J. M. MacLaren, *Phys. Rev. B* 63, 054416 (2001).
- [20] Y. Kato, R. C. Myers, A. C. Gossard, and D. D. Awschalom, *Nature (London)* 427 50 (2004).

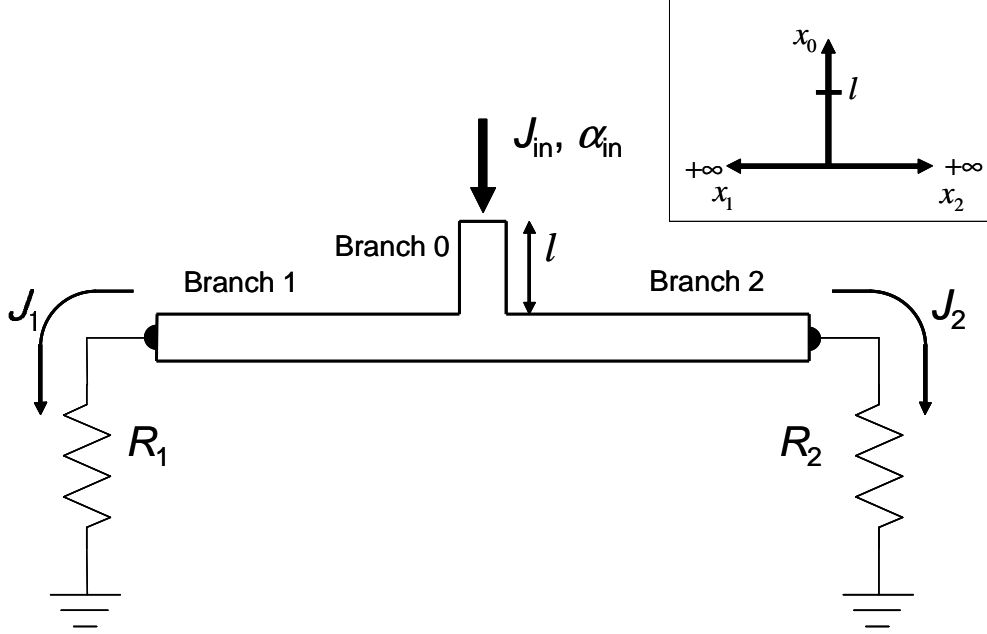

FIG. 1: Schematic diagram of the branching geometry. The current  $J_{in}$  with the spin polarization  $\alpha_{in}$  is injected to the input branch (branch 0) and splitted into the two output branches (branches 1 and 2) with the branched currents  $J_1$  and  $J_2$  ( $J_1 + J_2 = J_{in}$ ). The branching ratios  $\beta_1 = J_1/J_{in}$ ,  $\beta_2 = J_2/J_{in}$  can be modulated by the variable resistances  $R_1$  and  $R_2$ . When  $\beta_1, \beta_2$  are properly tuned, the spin polarization in the branch 1 or 2 can be amplified beyond  $\alpha_{in}$ . Inset: Coordinate system for the branching geometry. The branching point corresponds to  $x_0 = x_1 = x_2 = 0$ .

- [21] Z.G. Yu and M.E. Flatté, Phys. Rev. B 63, R201202 (2002).
- [22] Z.G. Yu and M.E. Flatté, Phys. Rev. B 66, 235302 (2002).
- [23] E.I. Rashba, Eur. Phys. J. B, 29, 513 (2002).
- [24] J.M. Kikkawa and D.D. Awschalom, Phys. Rev. Lett. 80, 4313 (1998).
- [25] L.B. Shao and D.Y. Xing, Phys. Rev. B 70, 201205 (2004).
- [26] W. Long, Q.-F. Sun, H. Guo, and J. Wang, Appl. Phys. Lett. 83, 1397 (2003).
- [27] J. Wang, K.S. Chan, and D.Y. Xing, Phys. Rev. B 72, 115311 (2005).
- [28] C. Benjamin and R. Citro, Phys. Rev. B 72, 085340 (2005).
- [29] A.A. Kiselev and K.W. Kim, Appl. Phys. Lett. 78, 775 (2001); J. Appl. Phys. 94, 4001 (2003).
- [30] Yu.A. Bychkov and E.I. Rashba, Sov. Phys. JETP Lett. 39, 78 (1984).
- [31] M. Yamamoto, T. Ohtsuki, and B. Kramer, Phys. Rev. B 72, 115321 (2005).

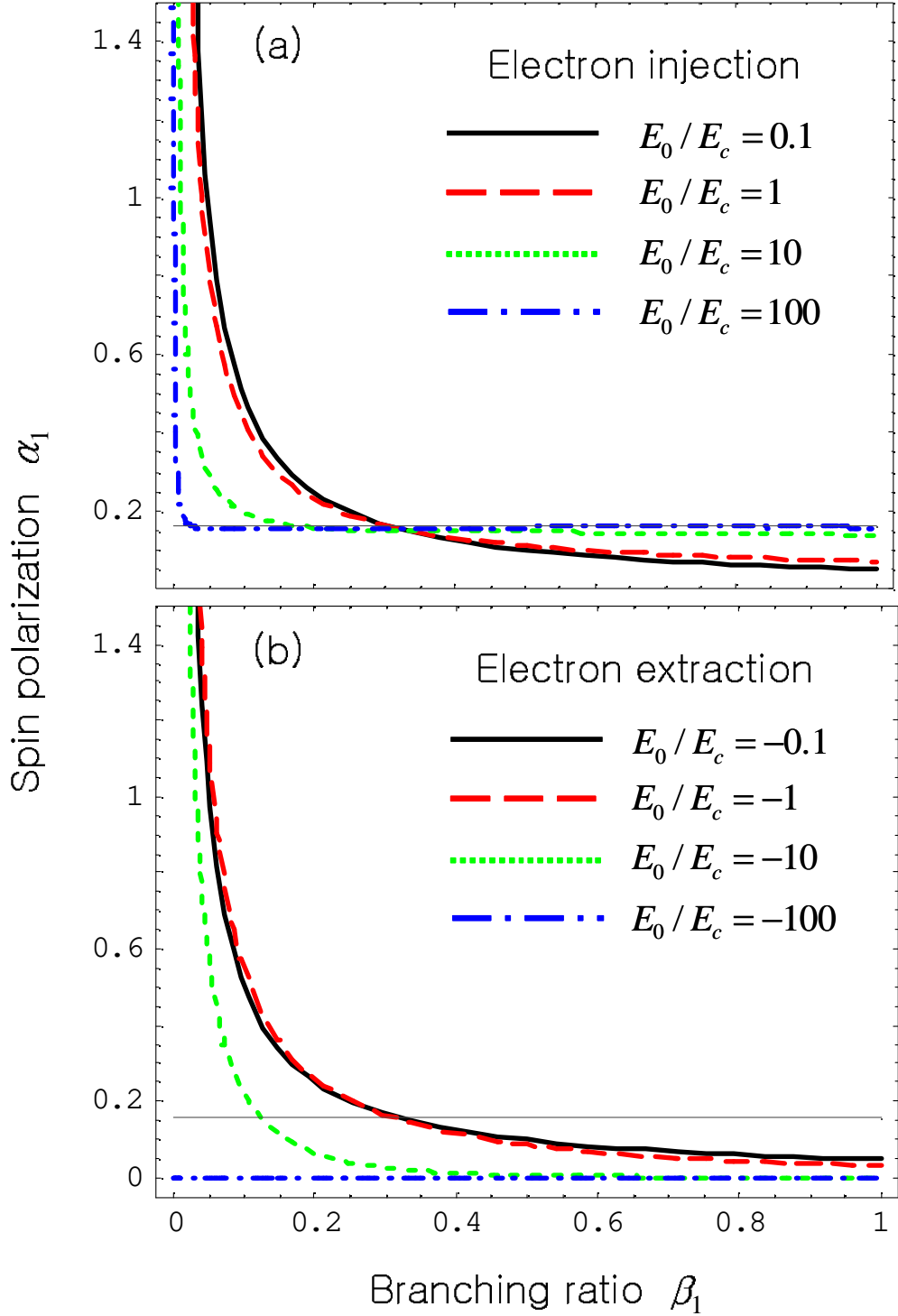

FIG. 2: (Color online) The spin polarization of the current in the branch 1 at  $x_1 = 0.3L_s$  (Fig. 1) as function of the branching ratio  $\beta_1 = J_1/J_{in} = E_1/E_0$ . Here the injection polarization  $\alpha_{in} = 0.16$  [horizontal solid lines in (a) and (b)] and  $l = 0.3L_s$  are assumed. (a) For electron injection into the branch 0 ( $J_{in} < 0$ ) with  $E_0/E_c = 0.1; 1; 10; 100$ . (b) For electron extraction from the branch 0 ( $J_{in} > 0$ ) with  $E_0/E_c = -0.1; -1; -10; -100$ .