

Switching 3-Edge-Colorings of Cubic Graphs

Jan Goedgebeur

Department of Computer Science
KU Leuven campus Kulak
8500 Kortrijk, Belgium
and

Department of Applied Mathematics, Computer Science and Statistics
Ghent University
9000 Ghent, Belgium
`jan.goedgebeur@ugent.be`

Patric R. J. Östergård

Department of Communications and Networking
Aalto University School of Electrical Engineering
P.O. Box 15400, 00076 Aalto, Finland
`patric.ostergard@aalto.fi`

In loving memory of Johan Robaey

Abstract

The chromatic index of a cubic graph is either 3 or 4. Edge-Kempe switching, which can be used to transform edge-colorings, is here considered for 3-edge-colorings of cubic graphs. Computational results for edge-Kempe switching of cubic graphs up to order 30 and bipartite cubic graphs up to order 36 are tabulated. Families of cubic graphs of orders $4n + 2$ and $4n + 4$ with 2^n edge-Kempe equivalence classes are presented; it is conjectured that there are no cubic graphs with more edge-Kempe equivalence classes. New families of nonplanar bipartite cubic graphs with exactly one edge-Kempe equivalence class are also obtained. Edge-Kempe switching is further connected to cycle switching of Steiner triple systems, for which an improvement of the established classification algorithm is presented.

Keywords: chromatic index, cubic graph, edge-coloring, edge-Kempe switching, one-factorization, Steiner triple system.

1 Introduction

We consider simple finite undirected graphs without loops. For such a graph $G = (V, E)$, the number of vertices $|V|$ is the *order* of G and the number of edges $|E|$ is the *size* of G . If all vertices of G have the same number of neighbors, then G is said to be *regular* and the number of neighbors is called the *degree*. A graph that is regular with degree k is called *k -regular*. The connected components of 1-regular and 2-regular graphs consist of edges and cycles, respectively. The smallest degree of regular graphs that cannot be easily characterized is 3. A 3-regular graph is called *cubic*. A regular graph with odd degree necessarily has an even order.

A subgraph $G' = (V, E')$ of $G = (V, E)$ is said to be *spanning* if each vertex in V is the endpoint of some edge in E' . A t -regular spanning subgraph is called a *t -factor*. A connected 2-regular spanning subgraph is a *Hamiltonian cycle*. A *decomposition* of a graph $G = (V, E)$ is a set of subgraphs of G whose edge sets partition E . A decomposition of a regular graph into t -factors is called a *t -factorization*. A 1-factor is also known as a *perfect matching*.

A *k -edge-coloring* is a partition of the edges of a graph into k (color) classes so that no adjacent edges are in the same class. Notice that we do *not* label the color classes in this work. Each edge-coloring with k unlabeled colors and no empty color classes corresponds to $k!$ edge-colorings with labeled colors. This must be taken into account, for example, when comparing counts from different studies—for example, our work and [3].

The smallest possible number of colors in an edge-coloring is the *chromatic index* of the graph. No two edges of a 1-factor are adjacent, and a decomposition of a k -regular graph into k 1-factors is equivalent to a k -edge-coloring of such a graph. Indeed, the terms 3-edge-coloring and 1-factorization of a cubic graph are used interchangeably in the current study.

As the edges of a k -regular graph cannot be properly colored with fewer than k colors, the chromatic index of a k -edge-colorable k -regular graph is k .

The complement of a 1-factor of a cubic graph is a 2-factor. In general, such a 2-factor may have cycles of arbitrary lengths, but two cases of special interest here are when all cycles have even length and when there is exactly one (that is, Hamiltonian) cycle. The first case is related to edge-coloring.

Theorem 1. *A cubic graph has a 3-edge-coloring iff it has a 2-factor with cycles of even length.*

We will refer to a 2-factor where all cycles have even length as an *even 2-factor*. Denoting the maximum vertex degree of the graph by Δ , by Vizing's

theorem [30] the chromatic index is either Δ or $\Delta + 1$. This partitions graphs into two classes, called *Class 1* and *Class 2*, respectively.

The chromatic index of a cubic graph is connected to several fundamental problems. Tait [28] discovered that the four-color problem is equivalent to showing that simple bridgeless connected planar cubic graphs have chromatic index 3. Consequently, a 3-edge-coloring of a cubic graph is occasionally called a *Tait coloring*. For nonplanar graphs, it is possible for simple bridgeless connected cubic graphs to have chromatic index 4, and such graphs are called *snarks*, typically also requiring the girth to be at least 5. Snarks are related to various important problems in graph theory, including the cycle double cover conjecture and the 5-flow conjecture.

Given a 3-edge-coloring of a cubic graph, the problem of finding more 3-edge-colorings is here considered. This is accomplished in the context of local transformations known as edge-Kempe switches. The impact of edge-Kempe switching on Class-1 cubic graphs up to order 30 and Class-1 bipartite cubic graphs up to order 36 is computationally evaluated. Edge-Kempe switching is further involved in cycle switching of Steiner triple systems. It is discussed how the cubic graph underlying cycle switching can be utilized to improve the established algorithm for classifying Steiner triple systems.

Notice that similar transformations can also be carried out for *vertex* colorings [4, 20], so a term that is not specifying the setting, such as “Kempe switching”, may cause confusion. We refer to [9] for a survey on graph edge-coloring.

This paper is organized as follows. In Section 2 cycle switching of Steiner triple systems is described. Cycle switching of Steiner triple systems is closely related to and form one motivation for studying edge-Kempe switching of 3-edge-colorings of cubic graphs, which is the topic of Section 3. An algorithm to compute the edge-Kempe equivalence classes is presented and is then used to computationally investigate edge-Kempe switching of cubic graphs up to order 30 (and for various subclasses of cubic graphs such as bipartite cubic graphs, planar cubic graphs, and 3-connected planar cubic graphs up to higher orders). Certain conjectures related to the number of 3-edge-colorings in cubic graphs are also computationally verified. Furthermore, two families of cubic graphs of orders $4n + 2$ and $4n + 4$ with 2^n edge-Kempe equivalence classes are presented. It is conjectured that there are no cubic graphs with more edge-Kempe equivalence classes. New families of nonplanar bipartite cubic graphs with exactly one edge-Kempe equivalence class are also obtained.

2 Cycle Switching of Steiner Triple Systems

A *Steiner triple system* (STS) is a pair (X, \mathcal{B}) , where X is a finite set of *points* and \mathcal{B} is a set of 3-subsets of points, called *blocks*, such that every 2-subset of points occurs in exactly one block. The size of the point set is the *order* of the STS, and an STS of order v is commonly denoted by $\text{STS}(v)$. STSs exist iff the order is

$$v \equiv 1 \text{ or } 3 \pmod{6}.$$

For more information about Steiner triple systems, see [11].

Given an STS (X, \mathcal{B}) , consider a block $\{a, b, c\} \in \mathcal{B}$. We define \mathcal{B}_a (resp. $\mathcal{B}_b, \mathcal{B}_c$) to be the set of blocks that contain a (resp. b, c), except $\{a, b, c\}$. All blocks in $\mathcal{B}_a \cup \mathcal{B}_b \cup \mathcal{B}_c$ intersect $X \setminus \{a, b, c\}$ in exactly 2 points and may therefore be considered as the set of edges E in the graph $G = (X \setminus \{a, b, c\}, E)$.

As each pair of points is in some block of an STS, G is 3-regular. Moreover, the edges coming from the blocks containing a given point $i \in \{a, b, c\}$ form a 1-factor of G , which we denote by F_i . Hence we have a 3-edge-coloring and the chromatic index of G is 3.

The fact that the local mapping of an STS to a 3-edge-coloring of G is reversible is the core of switching of Steiner triple systems: any other 3-edge-coloring of G also gives an STS. Finding 3-edge-colorings is not easy in general: the problem of determining whether a cubic graph has chromatic index 3 is NP-complete [18]. However, for a given 3-edge-coloring—which the original STS gives us—one may consider the following subset of easily computed transformations.

A basic property of 1-factors is that the union of two 1-factors, $F_i \cup F_j$, $F_i \cap F_j = \emptyset$, forms an even 2-factor; we denote the number of cycles of the 2-factor by m . As each of the m cycles of the 2-factor has two 1-factors (perfect matchings), $F_i \cup F_j$ has 2^m ordered pairs of 1-factors and 2^{m-1} unordered pairs of 1-factors, that is, 1-factorizations. So a total of 2^{m-1} 3-edge-colorings can in this way be obtained from one 3-edge-coloring. Any such edge-coloring can be obtained via a sequence of switches each of which takes place in just one of the cycles.

A maximal path or a cycle with edges colored with two colors is called an *edge-Kempe chain* and forms a central part of the work by Kempe [25] on the four-color theorem. The edge-Kempe chains of a 3-edge-colored cubic graph can only be cycles. Switching the colors of a 2-edge-colored cycle (or maximal path, in the general case) is called an *edge-Kempe switch* in graph theory. The transformation of blocks of a Steiner triple system induced by an edge-Kempe switch of G is called a *cycle switch* in design theory, and if

the length of the cycle is 4—the shortest possible—then it is called a *Pasch switch*, due to the name of the configuration of blocks involved. All of these switches are reversible.

Obviously, for Steiner triple systems, the block $\{a, b, c\}$ can be chosen arbitrarily, and the total number of 2-factors that can be considered for switching an STS(v) is $v(v-1)/2$. If all of these 2-factors consist of just one cycle, whereby nothing new can be found, the Steiner triple system is said to be *perfect*. No perfect Steiner triple systems of order less than or equal to 21 exist [21], and only sporadic examples of larger orders are known [16].

For all admissible orders up to 19, all Steiner triple systems of a given order are connected via a sequence of cycle switches [17, 22]. This property is obviously not possible for orders where perfect systems exist. One possible way of handling such cases is discussed in [12]. Another way is to transform 3-edge-colorings into arbitrary 3-edge-colorings rather than considering only edge-Kempe switches. Such transformations have earlier been proposed by Petrenjuk and Petrenjuk [27] and are more recently treated in [10]. For example, the perfect STSs of order 25 and 33 listed in [16] can in this way be transformed into STSs that are not perfect. See [26] for a survey on switching codes and designs.

Finally, let us have a brief look at the algorithm used for classifying the Steiner triple systems of order 19 in [23] (see also [24, Sect. 6.1]) and how the cubic graph discussed above actually plays a central role in a possible improvement of that algorithm. The original algorithm consists of three main phases: (i) classification of the structures of type

$$\{a, b, c\} \cup \mathcal{B}_a \cup \mathcal{B}_b \cup \mathcal{B}_c, \quad (1)$$

(ii) extending those structures to STS(v)s in all possible ways, and (iii) carrying out isomorph rejection amongst the STS(v)s thereby obtained.

The number of structures obtained in step (i) is the number of 3-edge-colorings of cubic graphs of order $v-3$, up to isomorphism. A core observation is now that extension in step (ii) only depends on the edges of the cubic graph $G = (X \setminus \{a, b, c\}, E)$ coming from (1), the precise blocks of (1) being irrelevant. Consequently, it suffices to consider each 3-chromatic cubic graph of order $v-3$ once in step (ii).

For example, for STS(19)s, the 14648 structures extended in step (ii) in [23] can be reduced as there are 4207 cubic graphs of order 16 and 3986 of these are 3-chromatic. For STS(21)s, the smallest open case as for classifying Steiner triple systems, the three corresponding numbers are 219104 (by [23]), 42110, and 40440. Notice that these are numbers for arbitrary graphs, that is, disconnected graphs are also included. Step (ii) is the most time-consuming

part of the algorithm, so the ratio of the numbers of instances is close to the ratio of the total run times.

3 Edge-Kempe Switching of 3-Edge-Colorings

The concept of edge-Kempe switching of 3-edge-colorings of cubic graphs was introduced in the previous section; in this section we shall investigate various aspects of such switching.

Due to the connection with the four-color problem, planar graphs have been of special interest in the work on edge-Kempe switching of 3-edge-colorings of cubic graphs, but also other particular classes of graphs have been considered. Some of these results can be found in [1, 2]. One extremal case is when there is exactly one 3-edge-coloring of a cubic graph. We will call such a graph *uniquely 3-edge-colorable*. For a better understanding, we include a proof of the following well-known result.

Theorem 2. *If a cubic graph has a unique 1-factorization—that is, a unique 3-edge-coloring—then it has exactly three Hamiltonian cycles.*

Proof. If the 3-edge-coloring is unique, edge-Kempe switching gives nothing new, and the union of two 1-factors (colors) must form a Hamiltonian cycle. This gives three Hamiltonian cycles. The theorem now follows as further Hamiltonian cycles would give different 3-edge-colorings. \square

Thomason proved [29] that the converse of Theorem 2 does not hold. In particular, he showed that all generalized Petersen graphs of the form $GP(6k + 3, 2)$ with $k \geq 0$ contain exactly three Hamiltonian cycles, but that they are not uniquely 3-edge-colorable if $k \geq 2$. So Thomason’s smallest counterexample is $GP(15, 2)$, which has order 30.

In [14, Table 7] all cubic graphs up to order 32 with exactly three Hamiltonian cycles are determined, and we generated all 3-edge-colorings of those graphs. In our work, we used two independent algorithms to generate all 3-edge-colorings of graphs. The first algorithm—which was already used and tested before in [6]—colors the edges one at a time, and the second algorithm generates all perfect matchings and then determines which combinations of three of these perfect matchings yield a partitioning of the edge set of the graph.

The computations for the cubic graphs up to order 32 with exactly three Hamiltonian cycles led to the following observation.

Observation 1. *There are exactly three cubic graphs up to 32 vertices with three Hamiltonian cycles that are not uniquely 3-edge-colorable: the generalized Petersen graph $GP(15, 2)$ of order 30 and two graphs of order 32.*

The two graphs of order 32 from Observation 1 can be obtained from $GP(15, 2)$ by blowing up a vertex to a triangle.

If an edge-coloring can be obtained from another through a sequence of edge-Kempe switches, then the edge-colorings are said to be *edge-Kempe equivalent* and belong to the same *edge-Kempe equivalence class*. Graphs with a unique edge-coloring (cf. Theorem 2) obviously have just one edge-Kempe equivalence class. Examples of other classes of graphs with exactly one edge-Kempe equivalence class include the prism graphs (also called circular ladder graphs), twisted (or crossed) prism graphs, and Möbius ladders of order divisible by 4 [1] (see Figure 1).

One may further consider automorphisms of the cubic graph to get another concept of equivalence which merges some of the edge-Kempe equivalence classes. However, such equivalence is not considered in this study (graph isomorphism was just briefly mentioned in Section 2).

In [20] Mohar poses the problem of classifying the bipartite cubic graphs that have exactly one edge-Kempe equivalence class. Belcastro and Haas [1] provide a partial answer to this problem.

Theorem 3. [1, Corollary 4.3] *Every planar bipartite cubic graph has exactly one edge-Kempe equivalence class.*

In [1] it is shown that twisted prism graphs (see Figure 1) have exactly one edge-Kempe equivalence class, and such a graph of order 12 is the smallest nonplanar bipartite cubic graph with exactly one edge-Kempe equivalence class. The next examples of nonplanar bipartite cubic graphs with exactly one edge-Kempe equivalence class can be found for order 16, one of which is again a twisted prism graph; the other two graphs out of three are shown in Figure 2.

We shall now prove that the graph in Figure 2b belongs to an infinite family of graphs with exactly one edge-Kempe equivalence class. Before defining the family, let us consider some definitions and basic results for ladder graphs. A *ladder graph* L_n , $n \geq 1$, is a graph isomorphic to $P_2 \times P_n$, and a *ladder graph with pendants* LP_n , $n \geq 1$, is a graph obtained by adding four pendant edges and vertices to L_n as shown in Figure 3. We say that the pendant edges e_a, e_b and e_c, e_d form *end pairs* and e_a, e_c and e_b, e_d form *side pairs*. (Arguably, LP_n looks more like a real-world ladder than the ladder graph L_n .) An attempt to 3-edge-color a ladder graph with pendants immediately gives the following lemma.

Lemma 1. *Consider a graph LP_n with n even. If the edges of an end pair have different fixed colors, then this uniquely defines the 3-edge-coloring of the entire graph, and the colors of the two edges of a side pair coincide. If*

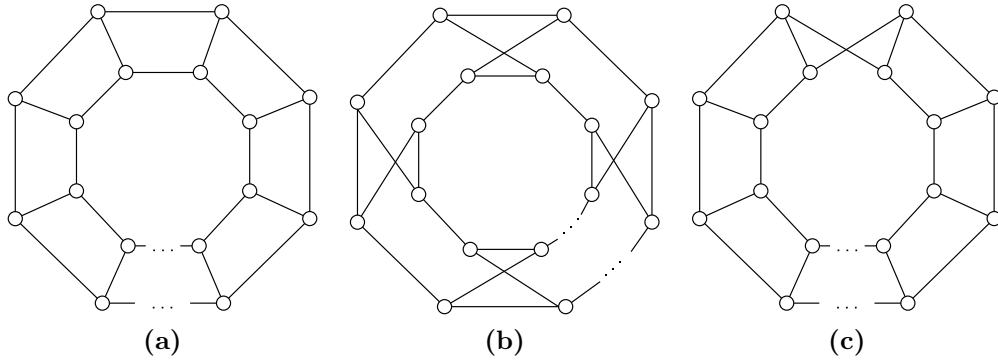

Figure 1: Prism graphs (a), twisted prism graphs (b), and Möbius ladders (c)

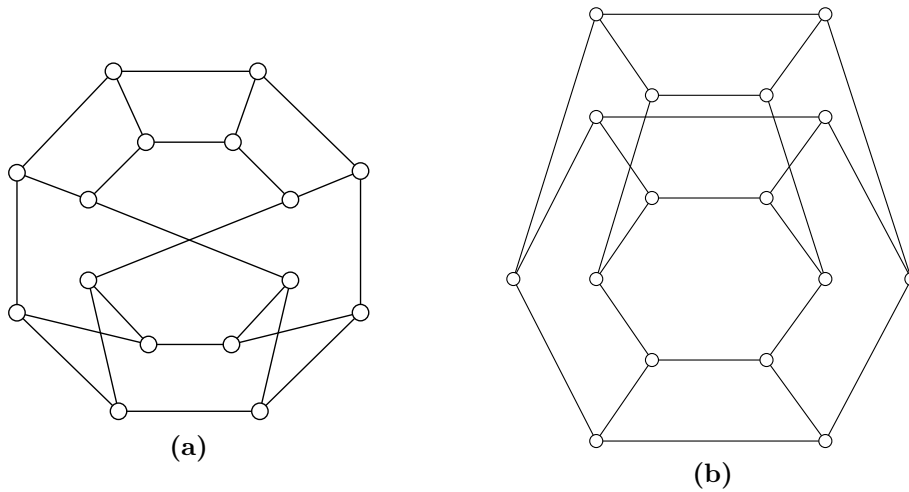

Figure 2: Two nonplanar bipartite cubic graphs of order 16 with exactly one edge-Kempe equivalence class

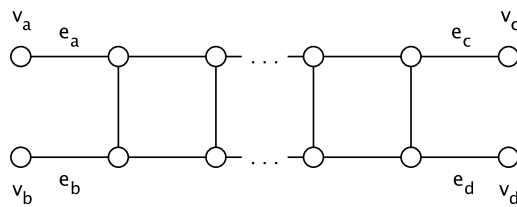

Figure 3: Ladder graphs with pendants

the edges of an end pair have the same fixed color, then also the colors of the edges of the other pair coincide.

Depending on the edge-coloring of an end pair, we say that a 3-edge-coloring of a ladder graph with pendants has type D (different) or S (same). For type S, it turns out that edge-Kempe switching is powerful in the following sense.

Lemma 2. *For $n \geq 2$ and a graph LP_n of type S with fixed colors for the end pairs, all 3-edge-colorings are in the same edge-Kempe equivalence class.*

Proof. The proof is constructive, that is, we shall show how an arbitrary 3-edge-coloring can be obtained from a given 3-edge-coloring via edge-Kempe switching. Starting from the edges of one end pair and their fixed colors, we shall proceed by considering the color of the edge incident to both of those, a *rung* of the graph LP_n . After this, the color of another pair of edges will be uniquely determined and this procedure will be iterated.

There are three possible situations when the current color of a rung is not the one we want, depicted in Figure 4 (coloring proceeds from the bottom to the top). In the relevant case, we (a) switch the colors ABAB of the edges of a 4-cycle, (b) switch the colors ABABAB of the edges of a 6-cycle, (c) first switch the colors ACAC of the edges of the upper 4-cycle and then switch the colors ABAB of the edges of the lower 4-cycle. Note that when we approach the end of the ladder, the colors of the pendant edges in that end restrict possible edge-colorings, so if the current color of the second to last rung is not the desired one, then only the situation in Figure 4a is possible and edge-Kempe switching in the 4-cycle finalizes the 3-edge-coloring. \square

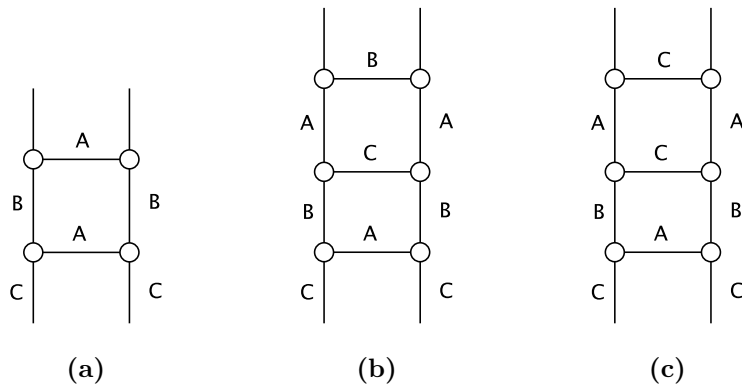

Figure 4: Ladder graphs with pendants used in the proof of Lemma 2

Now we define an *eggbeater graph* $E_{i,j,k}$ as the graph obtained by taking three graphs that are isomorphic to LP_i , LP_j , and LP_k and in the four cases

of $v_a, v_b, v_c,$ and v_d , merging the corresponding vertices of the three graphs. If $i, j,$ and k are even, then $E_{i,j,k}$ is bipartite and nonplanar. Nonplanarity is shown by taking the endpoints of a rung from each of the three ladders involved to get the vertices of a subgraph homeomorphic to $K_{3,3}$. The graph in Figure 2b is $E_{2,2,2}$.

Theorem 4. *The graph $E_{i,j,k}$, where $i, j,$ and k are even, has exactly one edge-Kempe equivalence class of 3-edge-colorings.*

Proof. Consider $E_{i,j,k}$ with $i, j,$ and k even. First consider all 3-edge-colorings where one of the three ladder subgraphs with pendants, say LP_i , is of type D (note that in later intermediate steps this subgraph can occasionally be of type S). By the property of Lemma 1, this situation may be considered with a graph G obtained by replacing LP_i by two edges, $\{v_a, v_c\}$ and $\{v_b, v_d\}$, as long as we can force switching in the original graph to take place so that e_a, e_c and e_b, e_d are always in the same cycle when switching. Indeed, for type D this is always the case, and for type S, by Lemma 2 we can always do edge-Kempe switching to get such a situation within the ladder subgraph.

Since G is planar and bipartite, by Theorem 3 all 3-edge-colorings of G are in the same edge-Kempe equivalence class, and the same holds for the edge-colorings of $E_{i,j,k}$ of the given type.

Next we consider the 3-edge-colorings of $E_{i,j,k}$ where all three ladder subgraphs with pendants are of type S. We shall constructively show how one such 3-edge-coloring can be obtained from another. We first consider the edges incident to v_a and v_b (and then similarly for v_c and v_d). We shall see how any two colors, say B and C, can be transposed, that is, we consider edge-Kempe chains with B and C. Moreover, to be able to treat the cases v_a, v_b and v_c, v_d separately, we need edge-Kempe chains that do not contain vertices from both of these pairs. Hence a chain going into a ladder subgraph from v_a should exit at v_b . Through proper switching we can make sure that this happens, and the cases in Figure 4 are relevant also here. As a part of an edge-Kempe chain, we have in case (a) CAC and, after switching BABA, CBC, and in case (b)/(c), CAC and CBCBC. Having done the edges incident to $v_a, v_b, v_c,$ and v_d —note that any permutation of three colors can be obtained by at most two transpositions of colors—Lemma 2 takes care of the rest.

Finally, we need to get between those main situations. For this, we take a 3-edge-coloring where all three ladder subgraphs with pendants are of type S and carry out switching to get a coloring that has an edge-Kempe chain through v_a and v_c (which is possible due to Lemma 2). Edge-Kempe switching then transforms the two involved ladder subgraphs with pendants from type S to type D. \square

Similar techniques can be used to obtain proofs and generalizations for other graphs encountered in our computational study, such as the graph in Figure 2a. It would be interesting to get more general characterization results for nonplanar bipartite cubic graphs with exactly one edge-Kempe equivalence class.

In [1] Belcastro and Haas also state questions about possible numbers of edge-Kempe equivalence classes for 3-edge-colorable bipartite cubic graphs and for arbitrary 3-edge-colorable cubic graphs. We shall now present the algorithm used in our computational study of these and other related questions.

In Algorithm 1 we give the pseudocode of our algorithm to determine the edge-Kempe equivalence classes of a given cubic graph. Notice that we essentially have a problem of finding the connected components of a graph where the vertices correspond to the 3-edge-colorings and the edges to the edge-Kempe switches. There are several ways of handling such implicit graphs, especially on the level of details (cf. [22]).

In the algorithm we first compute and store each 3-edge-coloring as a triple of bitvectors (a, b, c) , where bit i is set if the edge with number i is colored in the color associated with the bitvector. Recall that colors are not labelled, and this is taken care of by keeping the triple of bitvectors sorted, $a < b < c$. The list of stored 3-edge-colorings is sorted so that binary search can be used to find entries in logarithmic time (alternatively, a hash function can be used).

The set of 3-edge-colorings forms the set of vertices of the implicit graph, and edge-Kempe switching—which is done on-the-fly—gives the edges. The connected components of the graph can be determined using Algorithm 1, which is a standard DFS algorithm [19].

A 3-edge-coloring imposes three even 2-factors, which are formed by the three pairs of 1-factors (color classes). In the core of the recursion, edge-Kempe switching is carried out for every cycle of every 2-factor of every 3-edge-coloring, with two exceptions for performance reasons: (i) we do not switch the cycle that contains some fixed vertex v , and (ii) after performing a switch, we do not carry out the reverse of the switch as this would bring us to a edge-coloring that has already been visited. Exception (i) comes from the fact that switching all cycles of a 2-factor does not change a 1-factorization. Hence switching one cycle of a 2-factorization gives the same result as switching at once all other cycles in the 2-factorization, and therefore we may keep the edge-coloring of one of the cycles, the one containing the chosen vertex v , fixed. The fact that switching Hamiltonian cycles gives nothing new is a special case of this observation.

We used the *snarkhunter* [7] program to generate all cubic graphs and the

Algorithm 1 Edge-Kempe equivalence classes of a given cubic graph G

`edge-Kempe_switch(graph G)`

- 1: Generate and store all 3-edge-colorings of G
- 2: Let v be an arbitrary vertex of G
- 3: Initialize all 3-edge-colorings of G as not visited
- 4: **for** every 3-edge-coloring X of G **do**
- 5: **if** the 3-edge-coloring X has not been visited **then**
- 6: `edge-Kempe_switch_recursion(X,null,v)`
- 7: Output the edge-Kempe equivalence class of X
- 8: **end if**
- 9: **end for**

`edge-Kempe_switch_recursion(3-edge-coloring X , cycle C , vertex v)`

- 1: Mark the 3-edge-coloring X as visited
 - 2: **for** every even 2-factor F imposed by X **do**
 - 3: **for** every cycle $C' \neq C$ of F that does not contain v **do**
 - 4: Edge-Kempe switch C' to get an edge-coloring X' from X
 - 5: **if** the 3-edge-coloring X' has not been visited **then**
 - 6: Add X' to the edge-Kempe equivalence class being constructed
 - 7: `edge-Kempe_switch_recursion(X',C',v)`
 - 8: **end if**
 - 9: **end for**
 - 10: **end for**
-

two algorithms mentioned earlier—both of them, to validate the results—to generate all 3-edge-colorings of those graphs.

An implementation of Algorithm 1 can now be used to determine the number of edge-Kempe equivalence classes of all connected cubic graphs up to what is computationally feasible. The numerical results of our computations up to order 30 are shown in Table 1. For each order n , the number of graphs N , the number of graphs with zero edge-Kempe equivalence classes N_0 (that is, graphs that are not 3-edge-colorable), the number of graphs with exactly one edge-Kempe equivalence class N_1 , the number of graphs with the maximum number of edge-Kempe equivalence classes N_{\max} , and a list of the number of edge-Kempe equivalence classes which occur are given.

In Tables 2, 3, and 4 the results of the same computations are shown for connected bipartite cubic graphs, connected planar cubic graphs, and 3-connected planar cubic graphs, respectively. (We used *plantri* [8] to generate the 3-connected planar cubic graphs.)

The graphs from Tables 1 with the maximum number of edge-Kempe

Table 1: Edge-Kempe equivalence classes for connected cubic graphs

n	N	N_0	N_1	N_{\max}	# equiv. classes
4	1	0	1	1	1
6	2	0	1	1	1,2
8	5	0	4	1	1,2
10	19	2	9	1	0-2,4
12	85	5	44	4	0-4
14	509	34	188	3	0-5,8
16	4 060	212	1 258	15	0-6,8
18	41 301	1 614	8 917	7	0-10,16
20	510 489	14 059	75 630	81	0-12,16
22	7 319 447	144 712	680 055	25	0-18,20,32
24	117 940 535	1 726 497	6 496 848	469	0-22,24,32
26	2 094 480 864	23 550 891	63 963 867	111	0-36,40,64
28	40 497 138 011	361 098 825	644 968 468	3 132	0-38,40,42-44,48,64
30	845 480 228 069	6 137 247 735	6 606 598 953	588	0-60,62,64-66,68-70, 72,73,80,128

equivalence classes can be downloaded from [15] and from the database of interesting graphs from the *House of Graphs* [5] by searching for the keywords “maximum * edge-Kempe”.

In [1] a question is raised about the possible numbers of edge-Kempe equivalence classes. Our computational results show that all positive integers up to 106 are covered. Hence we make the following conjecture, which could also be made for more specific classes of graphs.

Conjecture 1. *For any positive integer m , there is a bipartite cubic graph with exactly m edge-Kempe equivalence classes.*

The following two theorems show the existence of an infinite family of graphs attaining the maximum number of equivalence classes in Tables 1 and 2.

Theorem 5. *There are bipartite cubic graphs of order $4n + 2$, $n \geq 1$, with 2^n edge-Kempe equivalence classes.*

Proof. We shall show that there are graphs of order $4n + 2$ with exactly 2^n 3-edge-colorings and for which all three 2-factors imposed by a 3-edge-coloring consist of just one cycle (which is a Hamiltonian cycle in the original graph). This implies that the size of each edge-Kempe equivalence class is 1, and the theorem follows.

Table 2: Edge-Kempe equivalence classes for connected bipartite cubic graphs

n	N	N_1	N_{\max}	# equiv. classes
6	1	0	1	2
8	1	1	1	1
10	2	0	1	2,4
12	5	2	1	1,2,4
14	13	1	3	1-5,8
16	38	6	2	1-4,8
18	149	4	7	1-10,16
20	703	24	13	1-8,10,12,16
22	4 132	28	25	1-18,20,32
24	29 579	140	67	1-16,18,20,24,32
26	245 627	244	111	1-36,40,64
28	2 291 589	1 026	453	1-30,32,34,36,40,48,64
30	23 466 857	2 588	588	1-58,60,62,64-66,68-70,72,73,80,128
32	259 974 248	10 066	3 112	1-52,54-56,58,60,62,64,66,68,70,72,80,96,128
34	3 087 698 618	30 848	3 469	1-106,108-110,112-114,116,120,124,128-130,132,136-138,140,144-146,160,256
36	39 075 020 582	117 304	22 832	1-104,106,108,110-112,114,116,118,120,124,128,130,132,136,138,140,144,146,160,192,256

Let $G = (V, E)$ be the graph shown in Figure 5. Obviously, this graph is bipartite. First consider the 1-factors that contain $\{v_a, v_b\}$. The graph induced by $V \setminus \{v_a, v_b\}$ consists of n subgraphs $K_{2,2}$ that are connected as shown in the figure. By induction, we shall now show that this graph has 2^n 1-factors.

If $n = 1$, then the 1-factor either contains $\{v_{1,0}, v_{2,0}\}$ and $\{v_{1,1}, v_{2,1}\}$, or $\{v_{1,0}, v_{2,1}\}$ and $\{v_{1,1}, v_{2,0}\}$, that is, there are $2 = 2^n$ possibilities. For arbitrary n , we have the same two possibilities for the edges containing $v_{1,0}$ and $v_{1,1}$. The graph induced by $V \setminus \{v_a, v_b, v_{1,0}, v_{1,1}, v_{2,0}, v_{2,1}\}$ consists of $n - 1$ subgraphs $K_{2,2}$ with the given structure. Hence the total number of 1-factors is $2 \cdot 2^{n-1} = 2^n$.

Consider a 1-factor F that contains $\{v_a, v_b\}$. To show that the 2-factor $E \setminus F$ consists of exactly one cycle, we show that it has a path from v_a to v_b . Indeed, a vertex $v_{i,j}$ with i odd is an endpoint of $\{v_{i,j}, v_{i+1,k}\} \in F$ and the neighbors in $E \setminus F$ are $v_{i-1,j}$ (v_a if $i = 1$) and $v_{i+1,1-k}$ (and similarly for the case of i even).

Finally, a 2-factor containing $\{v_a, v_b\}$ must form a path P from v_a to v_b after removing $\{v_a, v_b\}$. Hence, for $1 \leq i \leq n$, P must contain at least one

Table 3: Edge-Kempe equivalence classes for connected planar cubic graphs

n	N	N_0	N_1	N_{\max}	# equiv. classes
4	1	0	1	1	1
6	1	0	1	1	1
8	3	0	1	1	1
10	9	1	8	8	0,1
12	32	3	28	1	0-2
14	133	19	111	3	0-2
16	681	98	556	27	0-2
18	3 893	583	3 108	1	0-3
20	24 809	3 641	19 368	1	0-4,10
22	169 206	24 584	128 811	1	0-4,10
24	1 214 462	174 967	897 475	7	0-5,7,10
26	9 034 509	1 302 969	6 457 338	42	0-7,10
28	69 093 299	10 038 834	47 603 292	1	0-8,10,11
30	539 991 437	79 459 168	357 637 537	2	0-14,20

vertex of type $v_{i,j}$. Let i' be the smallest value of i for which P contains exactly one vertex of type $v_{i,j}$. But a vertex $v_{i',j'}$ cannot be in a 2-factor different from P since at most one of its neighbors in G is not in P . This completes the proof. \square

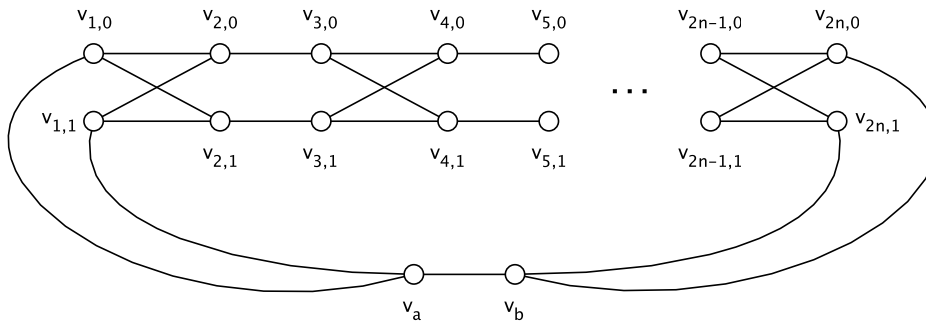

Figure 5: Graph for the proof of Theorem 5

The graphs for the proof of Theorem 5 are closely related to those for the proof of Theorem 6, so large parts of the proofs are analogous.

Theorem 6. *There are bipartite cubic graphs of order $4n + 4$, $n \geq 1$, with 2^n edge-Kempe equivalence classes.*

Table 4: Edge-Kempe equivalence classes for 3-connected planar cubic graphs

n	N	N_1	N_{\max}	# equiv. classes
4	1	1	1	1
6	1	1	1	1
8	2	1	1	1
10	5	1	1	1
12	14	13	1	1,2
14	50	47	3	1,2
16	233	210	23	1,2
18	1 249	1 096	1	1-3
20	7 595	6 373	1	1-4,10
22	49 566	39 860	1	1-4,10
24	339 722	260 293	6	1-5,7,10
26	2 406 841	1 753 836	31	1-7,10
28	17 490 241	12 087 721	1	1-8,10,11
30	129 664 753	84 809 873	2	1-14,20
32	977 526 957	603 748 613	55	1-15,17,20
34	7 475 907 149	4 350 914 098	1	1-20,23
36	57 896 349 553	31 685 445 136	1	1-24,29,30,45
38	453 382 272 049	232 863 258 652	1	1-26,28-30,32,35,40,45,100

Proof. We shall show that there are graphs of order $4n + 4$ with exactly 2^{n+1} 3-edge-colorings, such that each edge-Kempe equivalence class has size 2.

For $n \geq 2$, let $G = (V, E)$ be the bipartite graph shown in Figure 6, and consider the 1-factors that contain $\{v_a, v_c\}$. Such a 1-factor contains either $\{w_{1,0}, w_{2,0}\}$ and $\{w_{1,1}, w_{2,1}\}$, or $\{w_{1,0}, w_{2,1}\}$ and $\{w_{1,1}, w_{2,0}\}$ (2 possibilities), and it contains $\{v_b, v_d\}$. Finally, for the edges incident to the vertices in the set $V' = \{v_{1,0}, v_{1,1}, v_{2,0}, v_{2,1}, \dots, v_{2n-2,0}, v_{2n-2,1}\}$, there are 2^{n-1} possibilities by the argument in the proof of Theorem 5. This gives a total of $2 \cdot 2^{n-1} = 2^n$ possible 1-factors.

With arguments analogous to those in the proof of Theorem 5, for a 1-factor F that contains $\{v_a, v_c\}$, the 2-factor $E \setminus F$ consists of exactly two cycles, one with vertex set $\{v_a, v_b\} \cup V'$ and the other with vertex set $\{v_c, v_d, w_{1,0}, w_{1,1}, w_{2,0}, w_{2,1}\}$. Hence there are 2 possibilities for the set of two 1-factors that impose such a 2-factor, and the total number of 3-edge-colorings is $2^n \cdot 2 = 2^{n+1}$.

As in the proof of Theorem 5 we may conclude that a 2-factor containing $\{v_a, v_c\}$ must, after removing $\{v_a, v_c\}$ and $\{v_b, v_d\}$, have a path from v_a to v_b containing all vertices in V' and another path from v_c to v_d containing

all vertices in $\{w_{1,0}, w_{1,1}, w_{2,0}, w_{2,1}\}$, that is, it must be Hamiltonian. Consequently, switching gives nothing for the union of the 1-factor containing $\{v_a, v_c\}$ and any of the two other 1-factors. Switching with respect to the two other 1-factors leads to an edge-Kempe equivalence class of size 2, so the total number of edge-Kempe equivalence classes is $2^{n+1}/2 = 2^n$. For $n = 1$, the cubical graph of order 8 has 2 edge-Kempe equivalence classes, which completes the proof. \square

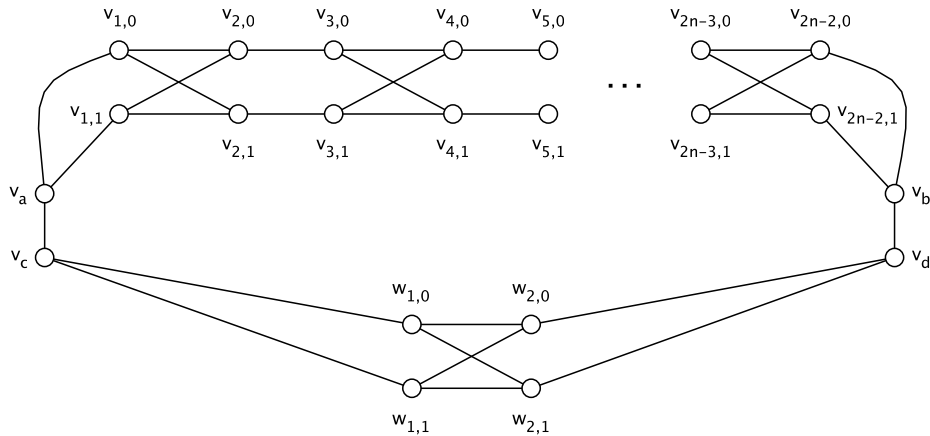

Figure 6: Graph for the proof of Theorem 6

We make the following conjecture.

Conjecture 2. *There are no cubic graphs with more edge-Kempe equivalence classes than those in Theorems 5 and 6.*

Notice that there are also other graphs than those in Theorems 5 and 6 with the same extremal property.

The graphs in Figures 5 and 6 can be obtained from twisted prism graphs (Figure 1) by a homomorphic mapping of, respectively, one and two $K_{2,2}$ subgraphs to $K_{1,1}$ subgraphs. Indeed, the graphs have a similar circular structure of basic subgraphs as conjectured extremal graphs for the maximum number of 3-edge-colorings [3] (prism graphs and Möbius ladders – see Figure 1) and Hamiltonian cycles [13] (the family displayed in Figure 7).

The conjectured maximum number of structures is $O(2^{n/2})$, $O(2^{n/3})$, and $O(2^{n/4})$ for 3-edge-colorings, Hamiltonian cycles, and edge-Kempe equivalence classes, respectively.

In our study, we have obtained further results for graphs with many 3-edge-colorings. Bessy and Havet [3] show that a connected cubic graph of order n can have at most $3 \cdot 2^{n/2-3}$ 3-edge-colorings, and in [3, Conjecture 13] they state the following conjecture.

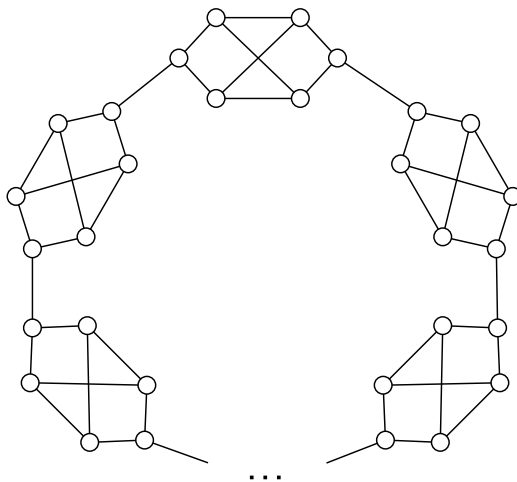

Figure 7: Graphs with many Hamiltonian cycles

Conjecture 3. *The connected cubic graph of order n with the largest number of 3-edge-colorings has $(2^{n/2-1} + 4)/3$ 3-edge-colorings if $n/2$ is even and $(2^{n/2-1} + 2)/3$ 3-edge-colorings if $n/2$ is odd.*

We have been able to get further evidence for Conjecture 3.

Observation 2. *Conjecture 3 holds at least up to order 30.*

Acknowledgements

We would like to thank Gunnar Brinkmann for useful suggestions. The observation at the end of Section 2 dates back to discussions with Petteri Kaski after the publication of [24]. Several of the computations for this work were carried out using the supercomputer infrastructure provided by the VSC (Flemish Supercomputer Center), funded by the Research Foundation Flanders (FWO) and the Flemish Government.

References

- [1] S.-M. Belcastro and R. Haas, Counting edge-Kempe-equivalence classes for 3-edge-colored cubic graphs, *Discrete Math.* **325** (2014), 77–84.
- [2] S. M. Belcastro and R. Haas, Edge-Kempe-equivalence graphs of class-1 regular graphs, *Australas. J. Combin.* **69** (2017), 197–214.

- [3] S. Bessy and F. Havet, Enumerating the edge-colourings and total colourings of a regular graph, *J. Comb. Optim.* **25** (2013), 523–535.
- [4] M. Bonamy, N. Bousquet, C. Feghali, and M. Johnson, On a conjecture of Mohar concerning Kempe equivalence of regular graphs, *J. Combin Theory. Ser. B* **135** (2019), 179–199.
- [5] G. Brinkmann, K. Coolsaet, J. Goedgebeur, and H. Mélot, House of Graphs: a database of interesting graphs, *Discrete Appl. Math.* **161** (2013), 311–314. Available at <https://hog.grinvin.org/>
- [6] G. Brinkmann, J. Goedgebeur, J. Hägglund, and K. Markström, Generation and properties of Snarks, *J. Combin. Theory Ser. B* **103** (2013), 468–488.
- [7] G. Brinkmann, J. Goedgebeur, and B. D. McKay, Generation of cubic graphs, *Discrete Math. Theor. Comput. Sci.* **13** (2011), 69–80.
- [8] G. Brinkmann and B. D. McKay, Fast generation of planar graphs, *MATCH Commun. Math. Comput. Chem.* **58** (2007), 323–357.
- [9] Y. Cao, G. Chen, G. Jing, M. Stiebitz, and B. Toft, Graph edge coloring: A survey, *Graphs Comb.* **35** (2019), 33–66.
- [10] N. J. Cavenagh and T. S. Griggs, Subcubic trades in Steiner triple systems, *Discrete Math.* **340** (2017), 1351–1358.
- [11] C. J. Colbourn, Triple systems, in: C. J. Colbourn and J. H. Dinitz (Eds.), *Handbook of Combinatorial Designs*, 2nd ed., Chapman & Hall/CRC, Boca Raton, 2007, pp. 58–71.
- [12] A. L. Drizen, M. J. Grannell, and T. S. Griggs, Pasch trades with a negative block, *Discrete Math.* **311** (2011), 2411–2416.
- [13] D. Eppstein, The Traveling Salesman Problem for Cubic Graphs, *J. Graph Algorithms Appl.* **11** (2007), 61–68.
- [14] J. Goedgebeur, B. Meersman, and C. T. Zamfirescu, Graphs with few Hamiltonian Cycles, *Math. Comp.* **89** (2020), 965–991.
- [15] J. Goedgebeur and P. R. J. Östergård, Dataset for Switching 3-edge-colorings of cubic graphs [Dataset]. Zenodo. <https://doi.org/10.5281/zenodo.4707697> (April 21, 2021).

- [16] M. J. Grannell, T. S. Griggs, and J. P. Murphy, Some new perfect Steiner triple systems, *J. Combin. Des.* **7** (1999), 327–330.
- [17] M. J. Grannell, T. S. Griggs, and J. P. Murphy, Switching cycles in Steiner triple systems, *Util. Math.* **56** (1999), 3–21.
- [18] I. Holyer, The NP-completeness of edge-coloring, *SIAM J. Comput.* **10** (1981), 718–720.
- [19] J. Hopcroft and R. Tarjan, Algorithm 447: efficient algorithms for graph manipulation, *Communications of the ACM* **16** (1973), 372–378.
- [20] B. Mohar, Kempe equivalence of colorings, *Graph Theory in Paris* (2006), 287–297.
- [21] P. Kaski, Nonexistence of perfect Steiner triple systems of orders 19 and 21, *Bayreuth. Math. Schr.* **74** (2005), 130–135.
- [22] P. Kaski, V. Mäkinen, and P. R. J. Östergård, The cycle switching graph of the Steiner triple systems of order 19 is connected, *Graphs Combin.* **27** (2011), 539–546.
- [23] P. Kaski and P. R. J. Östergård, The Steiner triple systems of order 19, *Math. Comp.* **73** (2004), 2075–2092.
- [24] P. Kaski and P. R. J. Östergård, *Classification Algorithms for Codes and Designs*, Springer, Berlin, 2006.
- [25] Ł. Kowalik, Improved edge-coloring with three colors, *Theoret. Comput. Sci.* **410** (2009), 3733–3742.
- [26] P. R. J. Östergård, Switching codes and designs, *Discrete Math.* **312** (2012), 621–632.
- [27] L. P. Petrenjuk and A. J. Petrenjuk, Weighted blocking designs and their transformations, *Svitohliad*, No. 3 (1996), 45–72.
- [28] P. G. Tait, Remarks on the colouring of maps, *Proc. Roy. Soc. Edinburgh* **10** (1880), 501–503.
- [29] A. G. Thomason, Cubic graphs with three hamiltonian cycles are not always uniquely edge-colorable, *J. Graph Theory* **6** (1982), 219–221.
- [30] V. G. Vizing, On an estimate of the chromatic index of a ρ -graph (in Russian), *Discret. Analiz.* **3** (1964), 25–30.