

The Incubator Case Study for Digital Twin Engineering

Hao Feng[†], Cláudio Gomes[†], Casper Thule[†], Kenneth Lausdahl[†],
Michael Sandberg[†], and Peter Gorm Larsen[†]

[†]DIGIT, Department of Electrical and Computer Engineering, Aarhus
University, Denmark

February 19, 2022

Abstract

To demystify the Digital Twin concept, we built a simple yet representative thermal incubator system. The incubator is an insulated box fitted with a heatbed, and complete with a software system for communication, a controller, and simulation models. We developed two simulation models to predict the temperature inside the incubator, one with two free parameters and one with four free parameters. Our experiments showed that the latter model was better at predicting the thermal inertia of the heatbed itself, which makes it more appropriate for further development of the digital twin. The hardware and software used in this case study are available open source, providing an accessible platform for those who want to develop and verify their own techniques for digital twins.

1 Introduction

Cyber-Physical Systems (CPSs) are integrations of computation with physical processes. Embedded computers act through a network, monitor and control the physical processes [1].

The cyber part refers to the computation part and communications, while the physical part refers to the part of the system interacting with the physical world. The environment is the part that may significantly affect the properties of the CPS but cannot directly be controlled.

An example of a CPS is a car. The physical part in the car contains a body, four wheels, seats, an engine, and so on, which interact with the environment (e.g., wind, road surface). The cyber part of the car is different control systems implemented in Electronic Control Units (ECUs) that communicate among themselves through a Controller Area Network.

Since systems are getting increasingly complex, models are needed to better comprehend their behaviour. A model is an abstract representation of a system, built with

the goal of understanding one aspect of the system [2]. For example, a Computer-Aided Design (CAD) model of a car may store information about the sizes of the wheels, shapes of the chassis, styles of the car, and so on, but it does not contain information about how the forces acting on the car affect its movement. An engineer who desires to analyse the dynamics of the car may build a dynamic model described by the differential equations introduced in, e.g., [3, Section 5].

Beyond better understanding, models can assist with optimising the overall system, discovering causes and effects, measuring consequences of changes, and communicating among engineers. Once the system is deployed, the models used to build it should not be discarded. Instead, they should be integrated into a Digital Twin (DT).

DT is often defined as a framework that integrates modelling, simulation, monitoring, and optimisation technologies, with the intent of adding value to the use of the Physical Twin (PT) [4,5]. For instance, a DT provides the ability to run simulations that reproduce and predict the behaviour of the PT under its current operating conditions. The following important parts are highlighted [6]:

Data – collected from the PT through sensors over time;

Models – knowledge about different aspects of both the cyber and the physics of the PT and its environment¹; and

Algorithms – techniques that use data and models, manipulating those to generate more data and knowledge (e.g., fault detectors, supervisory controllers, state estimators, optimisers).

An example common structure of a DT is represented in fig. 1. In fig. 1, the DT employs calibration algorithms to update the models of the CPS and environment with the best estimate of the parameters. The resulting data is then used to inform monitors that check whether the system is performing safely and optimally. When violations are detected, humans (or other algorithms) may decide to make changes to the physical twin.

DTs increase the value of their physical counterparts by potentially enabling advanced visualisations, reconfigurability (and therefore robustness with respect to changing environment), safety, predictability, and reduced maintenance.

The often vague definitions and claims about DTs makes the concept hard to distinguish from: self-adaptive systems [7, 8], autonomic computing [9], Industry 4.0 [10], models@runtime [11, 12], and supervisory controllers [13].

We introduce the Incubator case study as an attempt to clearly identify the techniques used in digital twinning. This system is a simple, yet representative, CPS and PT. Detailing how the DT is built is out of the scope of this manuscript, but we sketch how such implementation can be done, and which technologies can be used. This makes it easier for the reader to see the similarities of DT to the aforementioned related research areas.

The publicly available repository² contains the up-to-date hardware and software specifications of the case study.

The rest of the report is organized as follows: section 2 introduces the incubator

¹It is worth noting that models can be described at different levels of abstraction, and typically there is a tendency that accurate models also are very slow to analyse for example by means of simulation.

²<https://github.com/INTO-CPS-Association/example-incubator>

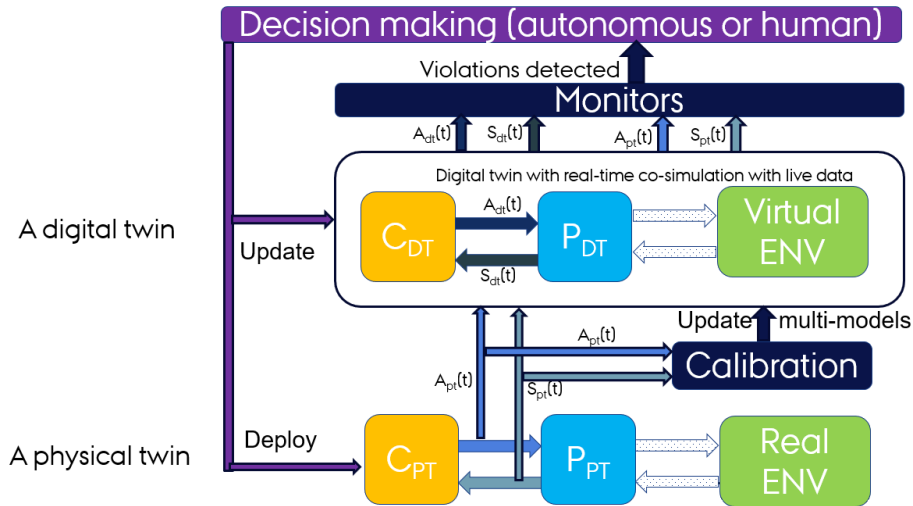

Figure 1: Schematic overview of a CPS-based Digital Twins. The letter “C” and “P” represents “Cyber” and “Physical” respectively.

system, including the hardware and software setup. Then we built two models with calibration method in section 3. section 4 shows two kinds of experimental results. Afterwards section 5 sketches the goals of the digital twinning and future work. Finally, we summarise the report in section 6.

2 Incubator Case Study

The main goal of the incubator is to reach a certain temperature within a box and regulate it regardless of the content inside. The physical components in the incubator form a plant that is controlled by a Raspberry Pi. The overall systematic diagram of the Incubator is shown in fig. 2.

2.1 Hardware Setup

We start with a brief description of the hardware components, back-of-the-envelope calculations, and refer the reader to the online repository³ for more details.

The plant of the Incubator consists of (see fig. 3):

- A styrofoam box in order to have an insulated container.
- A heatbed to heat up the content inside the styrofoam box.
- A fan to distribute the heating inside the box.
- Two temperature sensors to monitor the temperature inside the box.
- One temperature sensor to monitor the temperature outside the box.

³<https://github.com/INTO-CPS-Association/example-incubator>

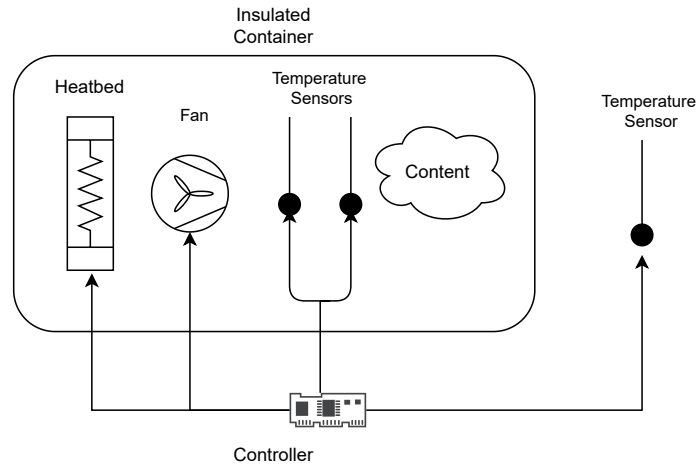

Figure 2: Schematic overview of the Incubator.

- A controller to communicate with the DT, actuate the heatbed, the fan, and read the temperature sensors.
- A Printed Circuit Board (PCB) connecting all electrical components.
- A power supply.

2.1.1 The Insulated Container

The aim of the insulated container (see fig. 3(a)) is to preserve the energy generated by the heatbed inside the box as much as possible, so as to minimise the potential impact of the environment around the CPS. We chose the styrofoam box (see fig. 3(a)) made of polystyrene for its good insulation properties.

The air volume inside the box is about $0.03m^3$. This value will be used for estimation of energy and air flow requirements.

2.1.2 The Heatbed

The heated content in the incubator is the air inside the box. The heatbed was used (see fig. 3(b)) as the surface heat source instead of a bar-like or point-like heat source. This is because we want to make the heat energy distributed as uniformly as possible.

Assuming that

- there is no heat transfer into the box walls,
- the mass of the air inside the box is $0.04kg$,
- the air heat capacity is $700J kg^{-1} K^{-1}$ and it does not change due to the temperatures, pressure and so on,

the heatbed can warm up the air inside the box from $293K$ ($20^{\circ}C$) to $300K$ (about $26.85^{\circ}C$), by producing

$$0.04kg * (300K - 293K) * 700J kg^{-1} K^{-1} = 200J$$



(a) The styrofoam Box is used as an insulated container.



(b) The heatbed is approximately $214 * 214 * 3$ mm to fit the styrofoam box.



(c) The Fan, used to circulate the air in the styrofoam box. It can be run on 12V or 24V.



(d) Raspberry Pi 4 Model B

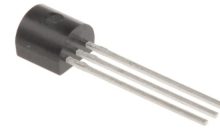

(e) Temperature Sensor

Figure 3: Components used in the incubator

of energy.

Assuming it delivers at least $100W = 100J s^{-1}$ of power, 200J be provided in under 2 seconds. As we will show later, this is more than enough power.

2.1.3 The Fan

We installed a fan (see fig. 3(c)) inside the box to circulate the air inside the box for making the temperature as uniformly distributed as possible. The fan airflow is about $0.02m^3 s^{-1}$.

With a box volume of $0.03m^3$, the fan should take 2 seconds to move all the air within the box.

2.1.4 The Raspberry Pi

A Raspberry Pi 4 Model B (see fig. 3(d)) was selected to implement the controller. The General Purpose Input/Output (GPIO) connectors on the Raspberry Pi can be used to connect many accessories such as temperature sensors, fan, and the heatbed. Furthermore it supports wireless internet out of the box, with built-in Wi-Fi and Bluetooth,

which simplifies deployment of the controller.

2.1.5 The Temperature Sensor

It is necessary to get feedback from the temperature sensors for feedback control. To do this, a DS18S20 High-Precision 1-Wire Digital Thermometer (see fig. 3(e)) was used for measuring the temperature. This temperature sensor can measure temperatures from $-55\text{ }^{\circ}\text{C}$ to $+125\text{ }^{\circ}\text{C}$ with an accuracy of $0.5\text{ }^{\circ}\text{C}$ from -10 to $+85\text{ }^{\circ}\text{C}$, which is suitable for the physical incubator. And each DS18S20 has a unique 64-bit serial code, which allows multiple DS18S20s to function on the same 1-Wire bus. Such 1-wire bus support to connect multiple sensors with only one GPIO. In the incubator system, three sensors were deployed for detecting the temperature.

2.1.6 The PCB Design

Controlling the heatbed requires approximately 4A current which is not supported by the Raspberry Pi. Instead, MOSFETs are used to separate the control signals from the Raspberry Pi and the driving currents. In order to decouple the control signals from the Raspberry Pi to the MOSFETs, we use optocouplers. The PCB schematic is shown in fig. 4.

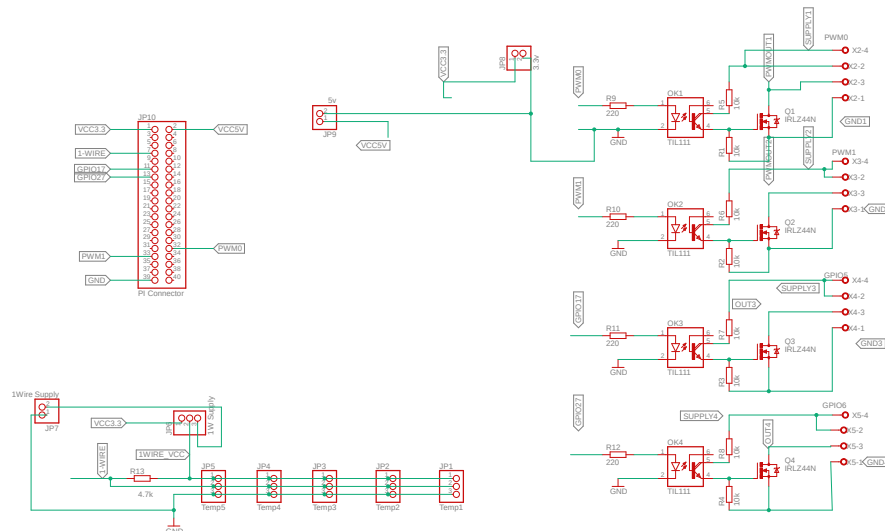
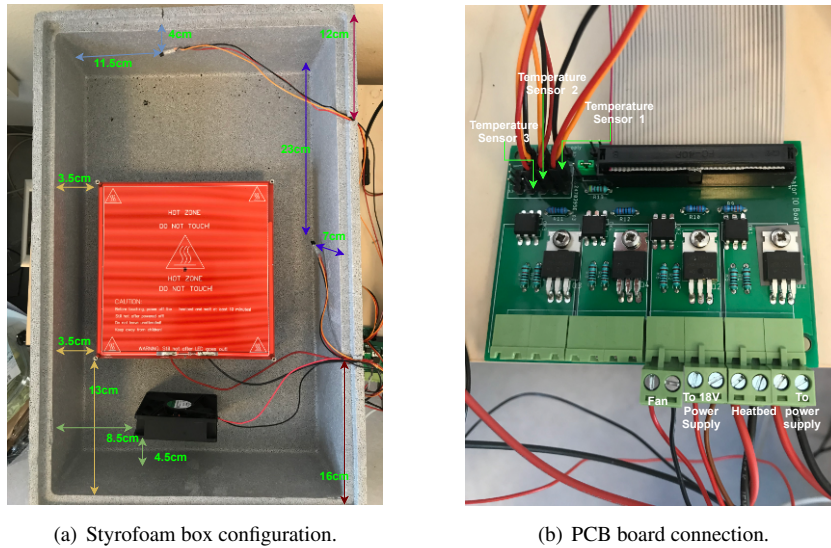

Figure 4: PCB schematics.

2.1.7 The Connections

The configuration details are shown in fig. 5.



(a) Styrofoam box configuration.

(b) PCB board connection.

Figure 5: Connections of components.

2.2 The Incubator Software Setup

The software setup includes a controller, a low-level driver, and a communication server for delivering data. Fig. 6 shows the schematic of the software system.

Communication Server – We used a Rabbit MQ server, running on the raspberry pi itself.

Low-level driver – Abstracts the low level communication with the sensors and actuators.

Controller – Implements the control logic required to regulate the temperature inside the incubator. It receives the measured data and sends commands through the communication server.

2.2.1 The Communication Server

For the case study, the RabbitMQ⁴ server was deployed for synchronisation and communication. With tens of thousands of users, RabbitMQ is one of the most popular open source message brokers. RabbitMQ is a mature, lightweight, and easy to deploy on premises and in the cloud.

⁴<https://www.rabbitmq.com/>

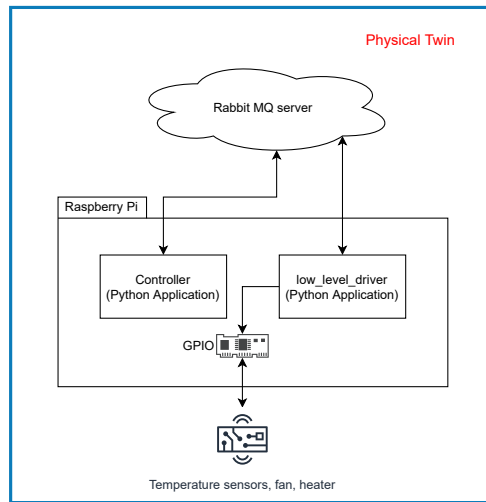

Figure 6: Schematic of the software deployment of the components.

The controller on the Raspberry Pi is listening from the RabbitMQ server for commands of controlling the fan and the heatbed and at the same time sharing the control states to the RabbitMQ server.

We choose RabbitMQ because it greatly facilitates the digital twinning process, as the DT can be implemented by components that listen to the messages being passed between the controller and the load level driver, as illustrated in fig. 7.

2.2.2 The Low-Level Driver

The low-level driver is used to interact with the PT and to issue the states of the PT to the RabbitMQ server. In order keep the device in a safe state, a safe protocol is incorporated into the low-level driver.

The low level driver periodically reads the temperature data, and checks if there are commands from the controller, through the communication server. The temperature data is uploaded to the communication server.

2.2.3 The Controller

The controller used in the case study is a comparable to a bang-bang controller, which a small difference described below. The control strategy is executed after receiving the temperature measurements.

The principle of bang-bang control is that when a reference temperature is given to the controller, the controller issues a heating signal turning on the heatbed until the measured temperature from sensors reaches the reference temperature. Because of the delayed effect of the temperature, the controller needs to wait after each actuation, to make sure the temperature does not rise too much. Figure 8 shows the state chart of the controller. The controller parameters are:

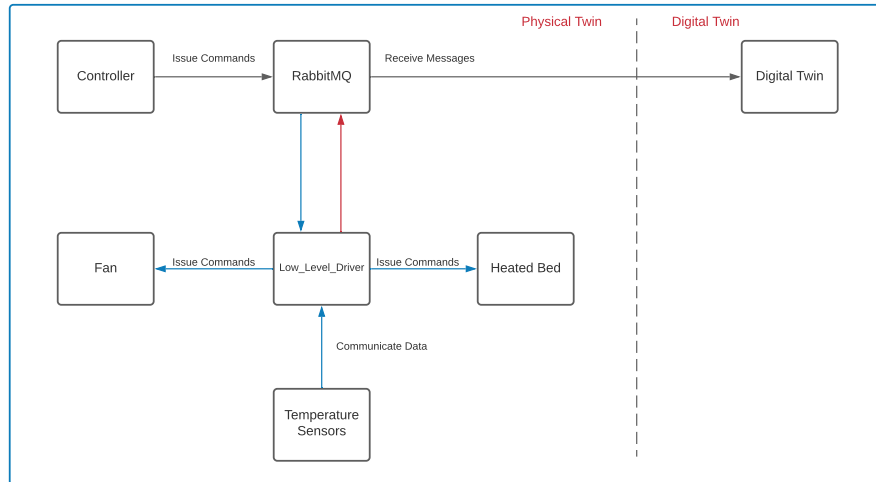

Figure 7: Overview of communication in the Incubator. The arrows represent the information flow.

- LL** – Lower limit for temperature;
- UL** – Upper limit for temperature;
- H** – Heating duration;
- C** – Waiting duration.

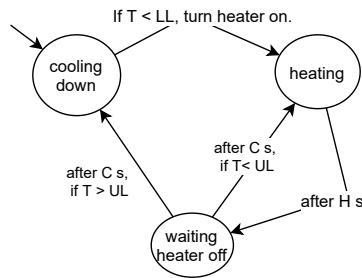

Figure 8: Controller Statechart.

3 Modelling the Physical Twin

The dynamics model we created mainly focuses on predicting the temperature inside the styrofoam box. To simplify the model, a few assumptions were made.

Assumption 1 *The temperature inside the box is distributed uniformly. This was accomplished by deploying a fan inside the box ensuring distribution of the air inside the box. We test this assumption in section 4.*

Assumption 2 *The box walls do not accumulate heat, or such heat accumulation has little effect on the air temperature inside the box.*

Assumption 3 *The specific heat capacity of the air inside the box is assumed constant, even when pressure and humidity may change.*

Assumption 4 *The majority of electrical power is transferred to heat energy, which means the heated inside the box does not absorb the heat energy and the heat energy generated by the fan was ignored as well.*

Two different models were built:

Model A: relies on all assumptions.

Model B: relies on all assumptions except Assumption 4.

To obtain the dynamic models of the temperature, the model was developed by considering the way the energy flows. If the amount of the energy used for heating the air is acquired, then this energy can be converted into the temperature inside the box by calculating a basic heat equation:

$$Q = cm\Delta T, \quad (1)$$

where Q represents the energy transferred, m equals the mass of the heated object, c is the specific heat capacity which is dependent on many factors such as temperature and pressure, in this project to simplify the dynamic model, c is considered to be constant, and not dependent of temperature and pressure following Assumption 3. ΔT is the temperature change either in Kelvin or in °C. All the units are SI-units. Based on this equation, the energy can be converted into temperature, which is the basis of the two time-dependent models.

We now explain the derivation of Model A, and Model B is described in section 3.2.

3.1 Model A

In model A, only the transformation of the energy between the air inside the box and outside of the box is considered. This means all the energy from the power supply is transferred to the air inside the box (recall Assumption 4 above). The total energy brought in by the power supply is:

$$E_{power.in} = VI\Delta t, \quad (2)$$

where V and I are the voltage and current provided by the power supply and Δt is the time interval.

Since the temperature of the air inside the box differs from that of the box, part of the energy flows from the air inside the box to the box. A parameter G_{box} (unit: J K^{-1})

was used to link the difference between the room temperature and the air temperature inside the box with the energy flowing to the box, which is:

$$E_{power_out} = G_{box}(T_{bair} - T_{room}), \quad (3)$$

where T_{bair} represents the temperature of the air inside the box and T_{room} is the room temperature.

By subtract eq. (3) from eq. (2), we can get the difference of the energy. Substitute the difference of the energy to the Q in eq. (1), a new equation is obtained:

$$\frac{dT_{bair}}{dt} = \frac{1}{c_{bair}m_{bair}}[VI\Delta t - G_{box}(T_{bair} - T_{room})]. \quad (4)$$

Since c_{bair} , the capacity of the air inside the box, is assumed to be constant but unknown and m_{bair} , the mass of the air inside the box, is a constant, a new parameter C_{air} (unit: J K^{-1}) is used to replace $c_{bair} * m_{bair}$. A more compact equation with model A is:

$$\frac{dT_{bair}}{dt} = \frac{1}{C_{air}}[VI\Delta t - G_{box}(T_{bair} - T_{room})]. \quad (5)$$

3.2 Model B

The main difference between Model B and Model A is that Model B relaxes Assumption 4. In other words, it considers the heatbed to also accumulate heat.

Similar to G_{box} , G_{heater} (unit: J K^{-1}) is used to describe the energy transferred from the heatbed to the air. The heat bed has its own specific heat capacity and mass. The energy transferred from the heatbed to the air is:

$$E_{heater2air} = G_{heater}(T_{heater} - T_{bair}). \quad (6)$$

And the energy retained in the heatbed is:

$$E_{heater} = VI\Delta t - E_{heater2air}. \quad (7)$$

This energy makes the temperature of the heatbed increase.

The process of energy flowing from the air to the box is the same as model A. The energy used for heating the air can be calculated by:

$$E_{air} = G_{heater}(T_{heater} - T_{bair}) - G_{box}(T_{bair} - T_{room}). \quad (8)$$

Both the energy E_{heater} and E_{air} are used for heating the heatbed and the air. According to eq. (1), the changes in the temperature of the heatbed and the air are:

$$\begin{aligned} \frac{dT_{heater}}{dt} &= \frac{1}{C_{heater}}(VI\Delta t - G_{heater}(T_{heater} - T_{bair})) \\ \frac{dT_{bair}}{dt} &= \frac{1}{C_{air}}[G_{heater}(T_{heater} - T_{bair}) - G_{box}(T_{bair} - T_{room})]. \end{aligned} \quad (9)$$

The model (eq. (9)) considered more detailed than Model A, has four parameters C_{heater} , C_{air} (unit: J K^{-1}), G_{heater} , and G_{box} (unit: J K^{-1}).

3.3 Calibration

Although the dynamics models have been built, they contain free parameters. In order to utilise the models, the models need to be calibrated for the incubator. The results of the calibration are detailed in section 4.2, and here we detail the procedure.

A non-linear least squares solver was used to calibrate the parameters of the models derived above. Then the models are evaluated using the estimated parameters. Afterwards the resulting behaviour is compared with a data trajectory that is obtained by running an experiment of the incubator. Finally using an optimisation function inside the python Scipy package [14] to obtain the values of the parameters. Such a function finds the parameters that minimizes the residual error. When the residual error is small enough, the optimised parameters can be obtained.

The principle of the package is based on least-square, it assumes that:

$$y = f(x, \theta) + \epsilon \quad (10)$$

where $f(x, \theta)$ is the model needed to be calibrated, θ are the parameters represented in a vector in the model, and y is the label or the measured data.

A cost function or an objective function can be provided as:

$$J = \sum (y_i - f(x_i, \theta))^2 \quad (11)$$

The objective is to acquire a minimal value of J , and at the same time, the corresponding θ are the value needed. In order to minimise the cost function, the most commonly used one is gradient descent. After multiple iterations, the value of the cost function goes to a sufficient small value and the θ are obtained simultaneously.

4 Experimental Results

Two kinds of experiments have been conducted. One is for testing Assumption 1. Another has been conducted to calibrate the parameters of the models. The source code used for the experiments is available online⁵.

4.1 Uniform Temperature Experiments

The temperature inside the box is assumed to be distributed uniformly, thanks to the fan. An experiment was conducted to test the uniformity of the temperature. In this case, it is not necessary to know the temperature of the room, so the sensor measuring the room temperature was used to test the air temperature inside the box. The setup with the sensors can be seen in fig. 9.

During the experiment, the fan is always turned on in order to circulate the air inside the box and the fan blows the wind from the bottom to the top in fig. 9. The heatbed was turned on during two periods. The experimental results are shown in fig. 10.

⁵<https://github.com/INTO-CPS-Association/example-incubator>

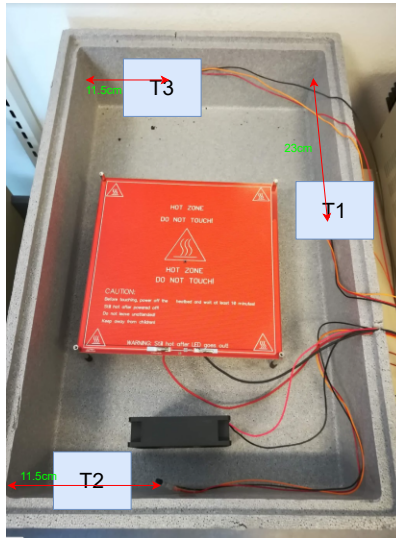

Figure 9: Three sensors are placed in different places.

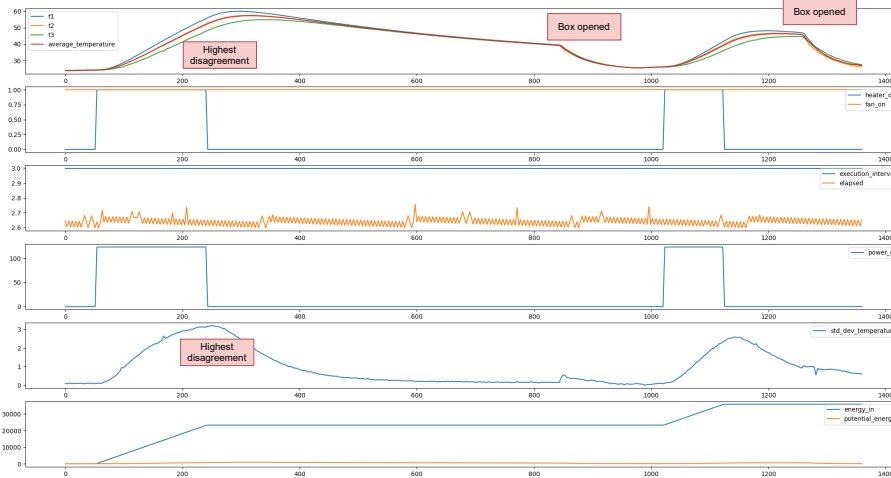

Figure 10: Experimental results of a uniform temperature inside the box. The first subfigure shows the temperatures measured from the three sensors change over time. The temperature measured from the sensor T2 is overlapped by the average temperature, which is hard to read. The other subfigures show different information regarding the experiment such as the status of the heatbed, the power introduced in the system, etc.

From the first subfigure in fig. 10, it seems that the temperature correlates with the distance to the heatbed and the average temperature matches the temperature measured

from T2 in fig. 9.

Since only three temperature sensors are included in the box and one is necessary for measuring the room temperature, sensor T2 in fig. 9 was rearranged to the new place in fig. 11 and sensor T1 in fig. 9 was taken to be outside of the box measuring the room temperature. The new setup of the sensors is shown in fig. 11. One was placed in the hottest position which is T2 position in fig. 11 and another one was placed in the coldest position, T3 position in fig. 11. Taking the average of those two, the average temperature of the air inside the box is acquired.

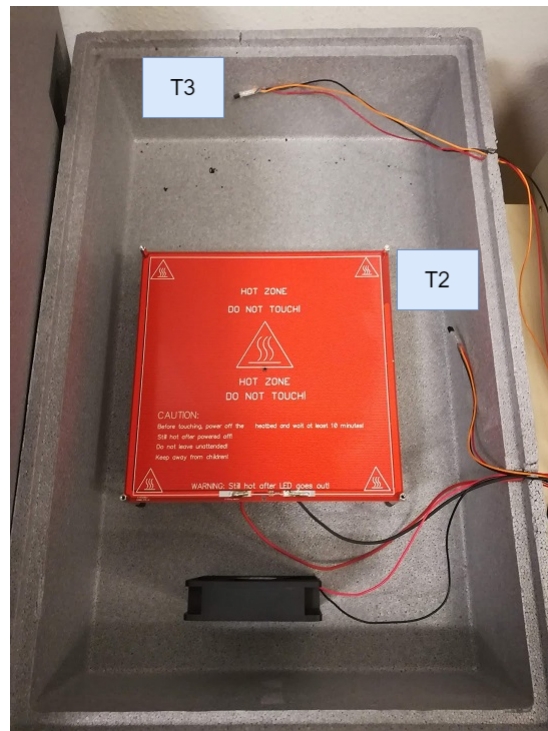

Figure 11: Optimized setup for sensors. The position of T2 and T3 are the same with fig. 9

In order to determine whether a stronger wind flow contributes a more uniform temperature, one additional experiment was conducted based on the setup in fig. 9. All the conditions were the same except the voltage of the fan which is $18V$ while in the previous experiment it was $12V$. The result is shown in fig. 12.

The previous setup in fig. 10 showed a discrepancy of a maximum of $7\text{ }^{\circ}\text{C}$ between the three temperature measurements while the maximum discrepancy in a new setup with 18 voltage on the fan is $6\text{ }^{\circ}\text{C}$.

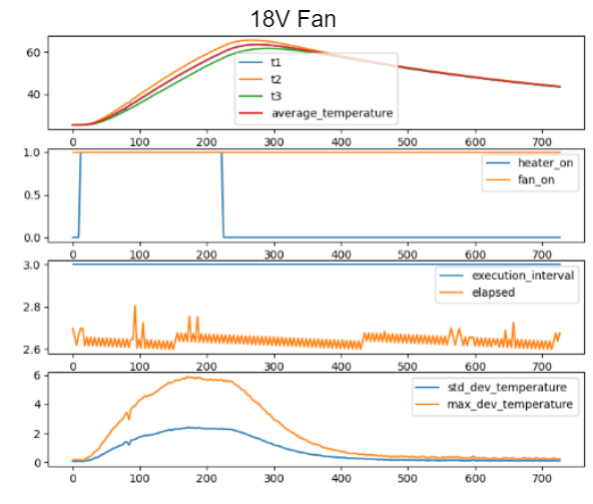

Figure 12: The experimental result with 18 voltage on the fan.

4.2 Calibration Experiment

Based on the optimised setup for sensors (fig. 11), a calibration experiment was conducted and the calibration method has been described in section 3.3. The experiment was used for generating a data trajectory. The calibrated parameters for the model A are $C_{air}(unit : JK^{-1}) = 616.56$ and $G_{box}(unit : JK^{-1}) = 0.65$. And the calibrated parameters for the model B are $C_{air}(unit : JK^{-1}) = 486.12$, $G_{box}(unit : JK^{-1}) = 0.856$, $C_{heater}(unit : JK^{-1}) = 33.65$, and $G_{heater}(unit : JK^{-1}) = 0.87$. The calibration result can be seen from fig. 13. Model A is sufficient to get a rough

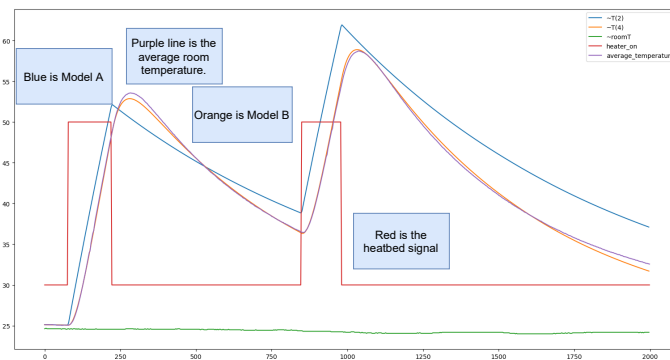

Figure 13: The calibration result.

approximation of the system magnitude and time scale, whereas the model B is better at predicting the inertia of the heatedbed itself.

5 Digital Twinning Goals

In this section, we sketch the goals of the digital twinning process for the incubator case study. This constitutes our future work.

Our goal is to implement a DT framework that enables

Real-time visualization of the incubator status – achieved by listening to the controller and low level driver messages, and relaying that data into a time series database, and plot the data into a dashboard.

On demand calibration – achieved by automatically running the calibration process described in section 3.3. This is similar to the tracking simulator implemented in [15].

Anomaly detection and Heatbed state estimation – This is achieved by running a Kalman filter [16] that uses Model B developed in section 3 and correlates the measure data to the (non-measured) heatbed temperature.

What-if simulations – This is implemented by running co-simulations that relay the historical or real-time data from the PT (e.g., similar to what is done in [17]). It can be used to, e.g., optimize the controller parameters introduced in fig. 8.

Self-adaptation loop – This is the functionality that truly *closes the loop* of the DT. We envision that, whenever a new object (imagine a bucket of cold water) is placed in the incubator, the DT will:

1. detect that the plant behavior has changed (given by the anomalies detected by the Kalman filter);
2. schedule an experiment to gather relevant data (e.g., let the plant cool down to a safe temperature, then ramp up heating for some time).
3. configure the controller for the new experiment;
4. gather the experiment data;
5. run the calibration of Model B for new experiment;
6. re-configure Kalman filter with new parameters;
7. run what-if simulations to optimize the controller behavior; and
8. finally re-configure the controller.

6 Summary

We described the implementation and modelling of the incubator case study. Hardware, software, and datasets are available online⁶. Using this example to set the terminology, we proceeded to demystify the DT concept and its goals.

⁶<https://github.com/INTO-CPS-Association/example-incubator>

References

- [1] Edward A. Lee. Cyber Physical Systems: Design Challenges. In *11th IEEE International Symposium on Object Oriented Real-Time Distributed Computing (ISORC)*, pages 363–369, 2008.
- [2] Thomas Kühne. What is a Model? In *Language Engineering for Model-Driven Software Development*, volume 04101. Internationales Begegnungs- und Forschungszentrum für Informatik (IBFI), 2005.
- [3] Dieter Schramm, Manfred Hiller, and Roberto Bardini. *Vehicle Dynamics*. Springer, 2014.
- [4] Fei Tao, He Zhang, Ang Liu, and A. Y. C. Nee. Digital Twin in Industry: State-of-the-Art. *IEEE Transactions on Industrial Informatics*, 15(4):2405–2415, April 2019.
- [5] Aidan Fuller, Zhong Fan, Charles Day, and Chris Barlow. Digital Twin: Enabling Technologies, Challenges and Open Research. *IEEE Access*, 8:108952–108971, 2020.
- [6] Louise Wright and Stuart Davidson. How to tell the difference between a model and a digital twin. *Advanced Modeling and Simulation in Engineering Sciences*, 7(1):13, December 2020.
- [7] Danny Weyns, M. Usman Iftikhar, Didac Gil de la Iglesia, and Tanvir Ahmad. A survey of formal methods in self-adaptive systems. In *Proceedings of the Fifth International C* Conference on Computer Science and Software Engineering - C3S2E '12*, pages 67–79, Montreal, Quebec, Canada, 2012. ACM Press.
- [8] Tao Chen, Rami Bahsoon, and Xin Yao. A Survey and Taxonomy of Self-Aware and Self-Adaptive Cloud Autoscaling Systems. *ACM Computing Surveys*, 51(3):1–40, June 2018.
- [9] J.O. Kephart and D.M. Chess. The vision of autonomic computing. *Computer*, 36(1):41–50, January 2003.
- [10] Heiner Lasi, Peter Fettke, Hans-Georg Kemper, Thomas Feld, and Michael Hoffmann. Industry 4.0. *Business & information systems engineering*, 6(4):239–242, 2014.
- [11] Nelly Bencomo, Robert France, Betty H. C. Cheng, and Uwe Aßmann, editors. *Models@run.Time*, volume 8378 of *Lecture Notes in Computer Science*. Springer International Publishing, Cham, 2014.
- [12] Nelly Bencomo, Sebastian Götz, and Hui Song. Models@run.time: A guided tour of the state of the art and research challenges. *Software & Systems Modeling*, 18(5):3049–3082, October 2019.

- [13] Mohammad Karimadini, Ali Karimoddini, and Abdollah Homaifar. A Survey on Fault-Tolerant Supervisory Control. In *2018 IEEE 61st International Midwest Symposium on Circuits and Systems (MWSCAS)*, pages 733–738, Windsor, ON, Canada, August 2018. IEEE.
- [14] SciPy 1.0 Contributors, Pauli Virtanen, Ralf Gommers, Travis E. Oliphant, Matt Haberland, Tyler Reddy, David Cournapeau, Evgeni Burovski, Pearu Peterson, Warren Weckesser, Jonathan Bright, Stéfan J. van der Walt, Matthew Brett, Joshua Wilson, K. Jarrod Millman, Nikolay Mayorov, Andrew R. J. Nelson, Eric Jones, Robert Kern, Eric Larson, C J Carey, İlhan Polat, Yu Feng, Eric W. Moore, Jake VanderPlas, Denis Laxalde, Josef Perktold, Robert Cimrman, Ian Henriksen, E. A. Quintero, Charles R. Harris, Anne M. Archibald, Antônio H. Ribeiro, Fabian Pedregosa, and Paul van Mulbregt. SciPy 1.0: Fundamental algorithms for scientific computing in Python. *Nature Methods*, 17(3):261–272, March 2020.
- [15] Christian Møldrup Legaard, Cláudio Gomes, Peter Gorm Larsen, and Frederik F. Foldager. Rapid Prototyping of Self-Adaptive-Systems using Python Functional Mockup Units. In *2020 Summer Simulation Conference, SummerSim '20*, page to appear, Virtual event, 2020. ACM New York, NY, USA.
- [16] Rudolph Emil Kalman. A New Approach to Linear Filtering and Prediction Problems. *Journal of Basic Engineering*, 82(1):35, March 1960.
- [17] Casper Thule, Cláudio Gomes, and Kenneth Lausdahl. Formally Verified FMI Enabled Data Broker: RabbitMQ FMU. In *2020 Summer Simulation Conference, SummerSim '20*, page to appear, Virtual event, 2020. ACM New York, NY, USA.