

# System Intelligence for UAV-Based Mission Critical with Challenging 5G/B5G Connectivity

Cristiano Bonato Both<sup>a</sup>, João Borges<sup>b</sup>, Luan Gonçalves<sup>b</sup>, Cleverson Nahum<sup>b</sup>,  
Ciro Macedo<sup>c</sup>, Aldebaro Klautau<sup>b</sup>, Kleber Cardoso<sup>c</sup>

<sup>a</sup>University of Vale do Rio dos Sinos - UNISINOS - São Leopoldo, Brazil

<sup>b</sup>Federal University of Pará - UFPA - Belém, Brazil

<sup>c</sup>Federal University of Goiás - UFG - Goiânia, Brazil

---

## Abstract

Unmanned aerial vehicles (UAVs) and communication systems are fundamental elements in Mission Critical services, such as search and rescue. In this article, we introduce an architecture for managing and orchestrating 5G and beyond networks that operate over a heterogeneous infrastructure with UAVs' aid. UAVs are used for collecting and processing data, as well as improving communications. The proposed System Intelligence (SI) architecture was designed to comply with recent standardization works, especially the ETSI Experiential Networked Intelligence specifications. Another contribution of this article is an evaluation using a testbed based on a virtualized non-standalone 5G core and a 4G Radio Access Network (RAN) implemented with open-source software. The experimental results indicate, for instance, that SI can substantially improve the latency of UAV-based services by splitting deep neural networks between UAV and edge or cloud equipment. Other experiments explore the slicing of RAN resources and efficient placement of virtual network functions to assess the benefits of incorporating intelligence in UAV-based mission critical services.

*Keywords:* Artificial intelligence, mission critical services, UAVs, beyond 5G

---

## 1. Introduction

Annually, the economic losses from global disasters sum hundreds of billions of dollars<sup>1</sup> and reap thousands of human lives. The impact on wildlife has more

---

\*Corresponding author

*Email address:* cbboth@unisinisinos.br (Cristiano Bonato Both)

<sup>1</sup><https://ourworldindata.org/grapher/economic-damage-from-natural-disasters>

diffuse numbers [1], but all of them expose a dramatic situation. Communication systems are fundamental tools in these scenarios, since they provide the means for proper coordination among the several teams involved in diverse tasks, from saving lives to repairing infrastructures. More recently, Unmanned Aerial Vehicles (UAVs) have been added as another valuable tools in the context of Mission Critical (MC) services, offering help on localizing people and animals, transporting medicines, improving communications, among other relevant tasks [2]. For example, Search and Rescue (SAR) missions are services usually performed in remote areas where the telecommunication infrastructure is inoperative or severely damaged due to disasters, and UAVs can be extremely helpful. However, the deployment and operation of UAVs in the Mission Critical (MC) context still depends strongly in human intervention, what limits its applicability and efficiency. Similar problem is observed with communication systems, mainly involving data transport, which is becoming the most relevant even in disasters scenarios. Considering these problems, standardization and adoption of Artificial Intelligence/Machine Learning (AI/ML) solutions are promising approach to tackle these issues [3].

In general, the investments in MC scenarios' resources aim at preventing losses, not in promoting profit. Therefore, it is essential to increase scale and reduce costs in any MC-related solution. The adoption of worldwide standards is a promising approach to achieve this goal. Additionally, international cooperation in MC scenarios is quite common and standards become again a natural choice. Nowadays, the 5th Generation (5G) and its evolution, i.e., Beyond 5G (B5G), are a key set of standards in the general context and also in the MC scenarios. MC communications have been a concern in the standardization bodies since long time, however, the focus has been in a specific set of MC services considered critical to teams involved in MC scenario. Additionally, the support for UAV is very recent, only considered effectively in the last 3rd Generation Partnership Project (3GPP) Releases, 15 [4] and 16 [5]. Nevertheless, these standards assume UAVs acting mainly as User Equipment (UE) and commanded by human beings. While fleets of autonomous UAVs, able to deploy and operate fully functional networks and services, have been investigated in the literature [6, 7, 8], this context is still considered futuristic and out of scope for the standardization bodies in the near future. In this article, we argue that AI/ML can turn this vision into reality sooner than is being expected.

AI/ML is already being widely adopted in UAV for autonomous operation [9]. Moreover, the standardization bodies of communication systems are in an advanced stage of defining how to adopt and deploy AI/ML [10]. However, the main efforts are focused on traditional infrastructure, i.e., without considering UAV as part of the whole system and acting not only as UE but also as part of the Radio Access Network (RAN) and even the 5G Core (5GC). Furthermore, UAVs can offer edge computing resources, which enables several new applications and

services. Finally, UAVs can provide temporary communication systems that are fully functional end-to-end. Software systems such as 5GC and the virtualized and disaggregated Radio Access Network (RAN) are receiving AI/ML updates to decrease the need for human intervention. While these updates may be enough for traditional infrastructure, they cannot deal with the challenging conditions faced by UAVs in MC scenarios. Additionally, each AI/ML solution is limited to its related system, disregarding the broader context that involves multiple interconnected systems, e.g., 5GC, RAN, and Multi-access Edge Computing (MEC).

The contributions of this article are two-fold: (i) we introduce the System Intelligence (SI) as an architecture for managing and orchestrating 5G/B5G communication systems that operate over a heterogeneous infrastructure, which includes UAVs. Besides describing SI and contextualizing it concerning existing standards, (ii) this article also contributes with results obtained with a testbed that supports experiments with UAV-based communications and AI in future networks and computer systems.

The proposed SI must support advanced MC services in several scenarios, including those in which only UAVs are available. SI focus on keeping all the essential systems interacting properly and operating with the best performance possible given the adverse conditions. Moreover, SI was designed following standards, mainly the European Telecommunications Standards Institute (ETSI) Experiential Networked Intelligence (ENI) specifications [10]. Regarding the results, one of the experiments indicates that SI can improve MC services by splitting neural networks between UAV and edge equipment, such that the latency decreases by 29.87%. In another experiment, it is shown that adequately slicing the resources leads to a decrease in average latency from 66 ms to 34 ms, approximately, when considering the downlink communication between UAV and edge.

The remaining of this article is organized as follows. In Section 2, we present the standardized approach's background, considering the main initiatives towards AI/ML solutions. In Section 3, we introduce our System Intelligence solution, and in Section 4, we show the experiments with AI for UAV-based SAR. We discuss the related work in Section 5 and present final remarks and suggestions for future work in Section 6.

## **2. Background**

In the last years, telecommunications standardization bodies, such as International Telecommunication Union (ITU-T), ETSI, 3GPP, as well as alliances between operators and manufacturers as Open Radio Access Network (O-RAN), published specifications about the design, development, and deploy of Artificial

Intelligence (AI)/Machine Learning (ML) for the 5G ecosystem and also its evolution, i.e., B5G. Together, these specifications encompass a wide scope, including the core, MEC, and RAN. Systems using AI in 5G/B5G networks will surely be based on these specifications. However, most AI systems used in 5G are not compliant to standards at the current maturity stage yet. Moreover, before AI systems become widespread, grasping all related specifications may be a daunting task. The specifications overlap and have gaps concerning some issues. Initially, this section briefly introduces the architectures defined by these standards, which cover 5GC, RAN, and MEC, and also the integration between them. After, the section presents a summary of the main initiatives considering the AI/ML's perspective for the 5G/B5G ecosystem. Besides providing a short review of these specifications for the reader's convenience, it is also vital to contextualize the proposed SI and indicate what can be used from the standards and what was missing.

The network system is mostly standardized by the 3GPP 5G, composed of the 5GC built as a Service-Based Architecture (SBA) [4] and the Next-Generation Radio Access Network (NG-RAN). An SBA allows flexible and stateless positioning of virtual environments in the network segments that make up a 5G system. Moreover, this architecture refers to how virtual networks' functions are created and deployed flexibly, widely using the concept of cloud computing to develop, deploy, and manage services. In this context, Releases 15 [4] and 16 [5] introduce several features to 5GC that are useful in the context of MC systems. For example, services can be implemented to expand the capabilities of a MC system, decomposing functions with low granularity, making the service light, and having a high capacity for sharing.

When contrasted with 3GPP specifications, the O-RAN Alliance introduced a complementary set of NG-RAN standards, gaining relevant support from the telecommunications industry. O-RAN addresses the split of the 5G base-station (gNB) in three parts: (i) O-RAN Radio Unit (O-RU), (ii) O-RAN Distributed Unit (O-DU), and (iii) Central Unit (CU). These splits for radio access technologies can be designed, developed, and deployed for the sake of saving costs or dealing with restrictions in energy consumption, such as in UAVs networks. In this context, 3GPP and O-RAN define a disaggregated RAN, composed of multiple Virtualized Network Functions (VNF). Therefore, we use the term virtual RAN (vRAN) throughout the article to emphasize that both NG-RAN and 5GC can be implemented as a collection of VNF that must be appropriately placed and chained to accomplish their tasks [11].

Given the importance of edge computing in MC scenarios, ETSI efforts in this area are briefly described. ETSI specified a MEC system as software-only entities to operate on top of a network edge's virtualization infrastructure [12]. This system consists of a platform to run applications on a particular virtualization in-

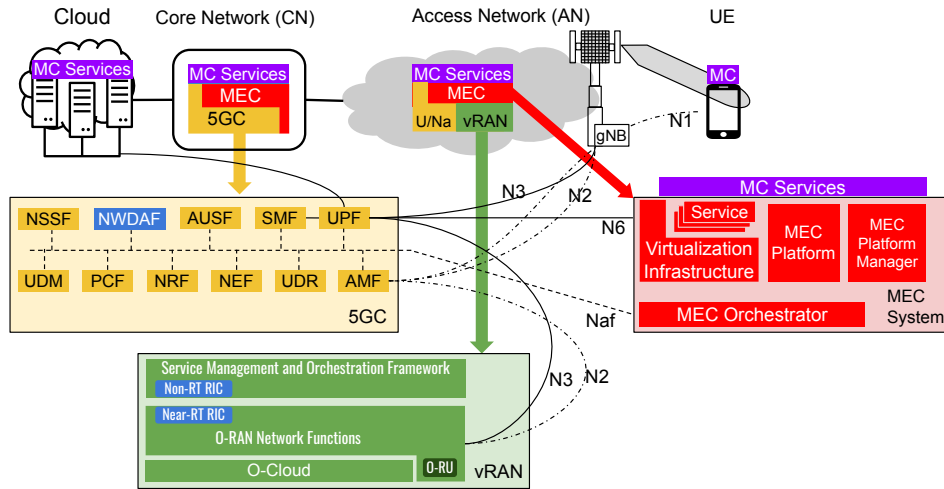

Figure 1: A standardized approach for supporting MC services based on the integration of 3GPP 5G system (mainly core), O-RAN, and ETSI MEC system. The AI/ML components already defined in the standards are highlighted in blue.

rastructure, a platform manager to handle the specific functionality’s management, and an orchestrator, which controls the whole system and services. Moreover, the MEC system is aligned with the SBA principles, and it was designed to be tightly integrated with 5GC [13]. Some of the essential MEC services depend on this integration, with Application Programming Interfaces (APIs) such as Radio Network Information API, Location API, UE Identity API, and Bandwidth Management API.

Figure 1 illustrates how MC services can be supported by a standardized set of systems composed of a 5GC, vRAN according to the O-RAN architecture, and an ETSI MEC system. All these systems can be seen as a large and complex collection of VNFs that must adequately be managed and orchestrated to support users’ application and services. The MC services add the challenge of managing and orchestrating these VNFs over an infrastructure composed mainly of UAVs and that can constantly change. Additionally, the figure illustrates how interconnected are multiple systems. In fact, Service-Based Interface (SBI) Network application function (Naf), and the reference points N1, N2, N3, and N6 are only some of the interconnections among the 5GC, vRAN, and MEC system. Finally, the figure highlights (in blue) the components related to AI/ML already introduced by the standards.

UAVs have been used to aid military and rescue operations under challenging

areas [14, 15], performing several tasks, such as surveillance, inspection, and mapping [16]. The presence of UAVs in these scenarios tends to increase, with them being used for even more applications, including disaster management [17, 18], performing MC tasks, leveraging the capacity of the new generation of mobile networks. However, it is good to note that MC services provided in disaster scenarios usually need to deal with reduced or even lack of radio coverage [19]. For instance, recent hurricanes occurrences, such as Hurricane Maria, resulted in the degradation of the functionality of about 95.6% and 76.6% of cellular sites in the affected areas [20]. In this context, the rescue team needs to ensure that its UAVs will receive the radio resource allocation dynamically during the mission through a network slice, guaranteeing the necessary throughput and latency, for example, video streaming and remote control.

In MC scenarios, 5GC, vRAN, and MEC must be improved to be operational under the eventual harsh conditions imposed by the environment. In other words, MC is challenging enough to require functionalities that are not still incorporated in current specifications. When seeking a solution that supports MC, part of this solution can be obtained from 3GPP specifications that describe the 5GC architecture. For example, when considering the AI required by MC systems, the component called Network Data Analytics Function (NWDAF) is the approach of 3GPP for meeting the AI perspective in the 5G system written in Release 15 [4] and 16 [5]. This component is responsible for collecting several types of information from the network and its users. Any core component and external access can consume the services provided by NWDAF. The analytical data produced by NWDAF can be used by an AI agent that specifies actions in the network context, for example, for UAV-based critical missions. In this case, the 5GC plays proactively and takes real-time decisions to provide the necessary services to 5G users, and NWDAF becomes a central point for analytics in the 5G network.

Complementing 5GC by 3GPP, the O-RAN architecture defines an AI perspective, including the AI-enabled RAN Intelligent Controller (RIC) for both non-Real-Time (non-RT) and near-Real-Time (near-RT) [9]. The non-RT functions include service and policy management, higher layer procedure optimization, and model training for the near-RT RAN functionality. The near-RT RIC is fit with radio resource management and improves operational functions such as seamless handover control, Quality of Service (QoS) management, and connectivity management.

The specifications published by 3GPP and O-RAN are fundamentals and applied for using of AI/ML solution on 5GC and vRAN, respectively. In a broader scope, ITU-T and ETSI published a set of manuscripts to define terminology, requirements, functionalities, and other essential concepts for characterizing AI integration into communication networks. We organize the manuscripts from these two standardization bodies considering the AI perspective in Figure 2 and sum-

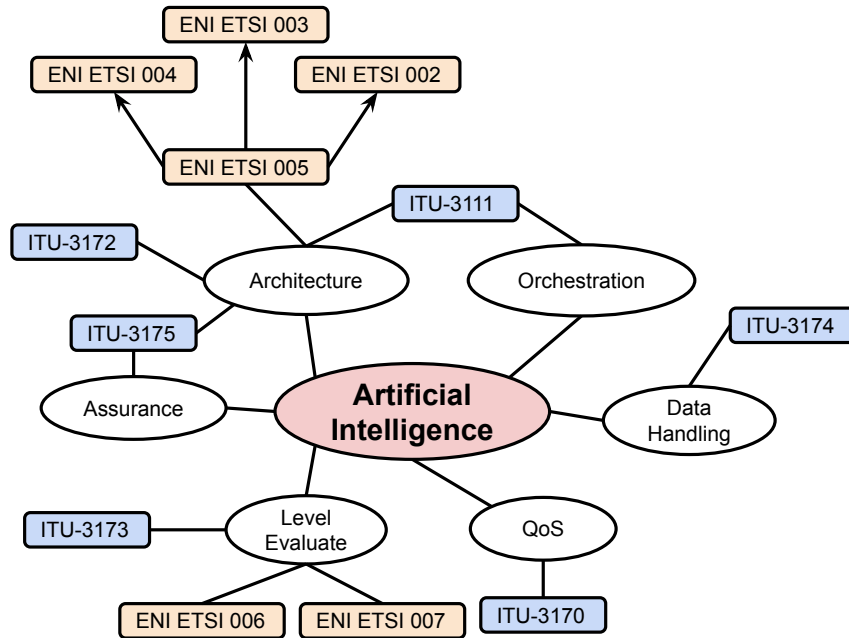

Figure 2: Artificial intelligence standards for communication networks by ITU and ETSI.

marize these specifications in Table 1. ITU-T introduces six main specifications that cover AI in a next-generation network. These recommendations focus on several aspects of the design of an AI framework. For example, ITU-3111 presents the network management and orchestration framework, and ITU-3170 shows the requirements for machine learning-based QoS assurance for the network. Moreover, ITU-3172 introduces the architectural framework for machine learning, and ITU-3173 discusses the framework for evaluating the intelligence levels of networks. Furthermore, ITU-3174 considers the framework for data handling to enable machine learning, and ITU-3175 covers the functional architecture of machine learning-based quality of service assurance in the networks.

Figure 2 also identifies some key ETSI documents. ENI ETSI 006 and 007 address concepts and definitions of categories for AI applications to networks, such as planning and optimization, service provisioning and assurance, data management, operator experience, etc. Moreover, ENI ETSI 0055 presents a high-level architecture for experiential networked intelligence [10], as well as additional contents showing experimental network requirements (ENI ETSI 002), context-aware policy management (ENI ETSI 003), and terminology for experimental networks

Table 1: AI/ML specifications by ITU-T and ENI ETSI

<b>Specification</b>	<b>Title</b>
ITU-3111	Network management and orchestration framework
ITU-3170	Requirements for ML-based quality of service assurance for the IMT-2020 network
ITU-3172	Architectural framework for ML in future networks including IMT-2020
ITU-3173	Framework for evaluating intelligence levels of future networks including IMT-2020
ITU-3174	Framework for data handling to enable ML in future networks including IMT-2020
ITU-3175	Functional architecture of ML-based QoS assurance for the IMT-2020 network
ENI ETSI 002	ENI requirements
ENI ETSI 003	Context-Aware Policy Management Gap Analysis
ENI ETSI 004	Terminology for Main Concepts in ENI
ENI ETSI 005	Experiential Networked Intelligence - System Architecture
ENI ETSI 006	Proof of Concepts Framework
ENI ETSI 007	Definition of Categories for AI Application to Networks

(ENI ETSI 004). This architecture is referred to as an Assisted System (AS) composed of three classes that represent: (i) no AI-based capabilities, (ii) AI is not in the control loop, and (iii) AI capabilities in its control loop. Additionally, the architecture designs an API Broker to serve as a gateway between different systems.

Even with such a relatively short review, it is clear that the body of recent work aiming at defining how AI/ML should be used in future networks is considerable. Before some of these recommendations become widely adopted in the industry, it is essential to identify how they can be put together and what remains to be defined. The next section uses some key aspects of these recommendations and describes missing elements to compose an intelligent system suitable for critical missions.

### 3. System Intelligence

In this section, we describe our proposal in detail, i.e., SI, and how it can deal with the challenging scenarios previously introduced. Since adherence to stan-



dards is one of our primary concerns, we built SI mainly in compliance with ETSI ENI [21]. However, while ENI is a general-purpose abstract specification, SI is an instantiation of the ENI ideas, being focused on MC services scenarios and taking into account a complex infrastructure that includes computing devices, gNBs, and, mainly, UAVs.

In Figure 3, we illustrate the introduction of SI and its integration with the standardized systems previously presented. Similar to the ENI specification [21], these systems that are managed by or receive recommendations from SI are named *Assisted Systems*. Moreover, as in [21], we recognize that each assisted system may present a distinct level in terms of capabilities related to AI/ML-based decision-making. However, we adopt a different terminology to categorize the systems, which is more appropriate to the MC services context, as described in the following.

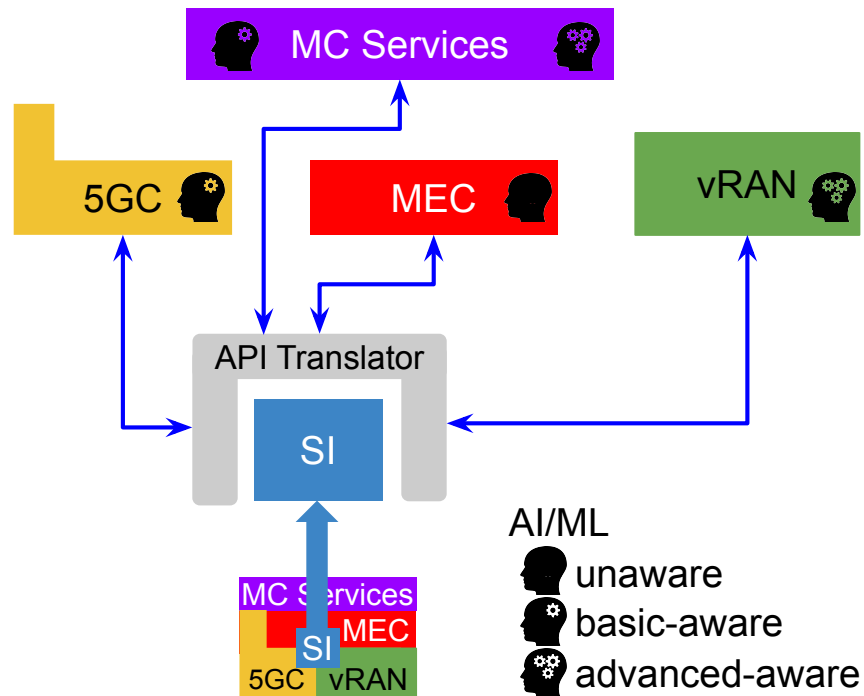

Figure 3: System Intelligence integration with the main Assisted Systems of the Mission Critical scenarios.

We consider the MEC System as *AI/ML unaware*, which means that it has no AI/ML-based decision-making capabilities. We categorize 5GC as *AI/ML basic-*

aware, since it has some AI/ML-based decision-making capabilities, mainly characterized by the NWDAF component. Finally, we consider vRAN, as defined by O-RAN, an *AI/ML advanced-aware* system, which means the existence of sophisticated AI/ML-based decision-making capabilities, including an internal AI in the control loop. MC services are provided by multiple AI/ML applications, which can be either basic-aware or advanced-aware. From any category, SI only needs a set of APIs that allows it to obtain data from the assisted system (related to its state) and to provide commands or recommendations for how to act, in general, to achieve a specific goal. It is important to highlight that no change is necessary for any assisted system to interact with SI appropriately. Actually, not even APIs need any adjustment. As illustrated in Figure 3, a component named *API Translator* is responsible for translating between APIs of SI and APIs of the Assisted Systems, if necessary.

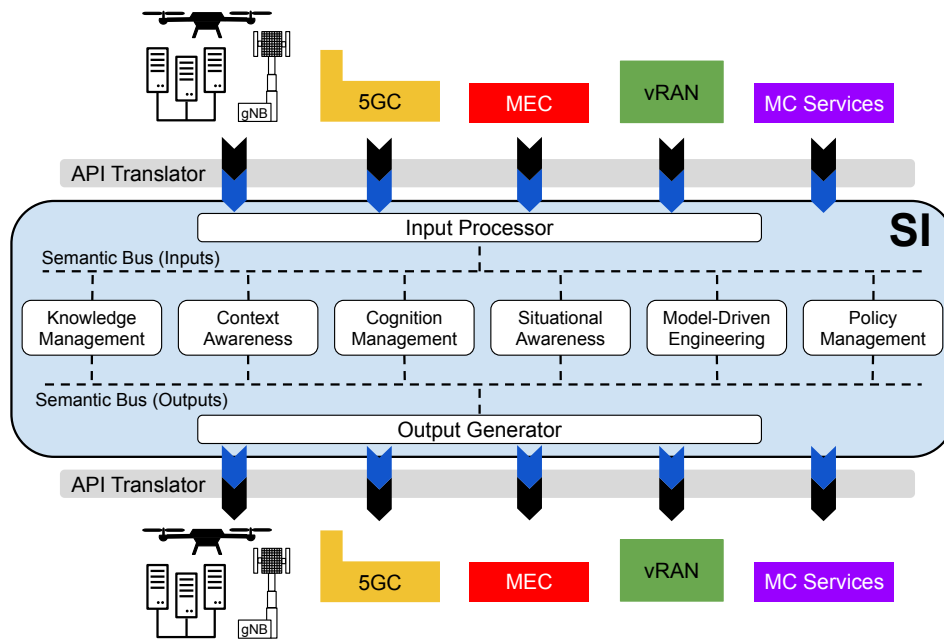

Figure 4: System Intelligence architecture based on ETSI ENI architecture.

The main elements of SI are presented in Figure 4. The *Input Processor* element handles several types of data from different sources using connection points between the *API Translator* and the external systems, e.g., 5GC, MEC, and vRAN. These data are normalized and forwarded to the *Semantic Bus*, which connects with the six internal SI elements [9]. These internal elements generate results from

processing and making decisions based on these standardized data. The results can be new facts or new hypotheses, which can later be converted into actions (by the *Output Generator*) to be applied to the systems. In the following, we describe each of the internal SI elements and introduce their deployment considering MC services and the infrastructure components, especially UAVs.

### *Knowledge Management*

This component defines formalism for representing information and knowledge, enabling the SI to analyze, apply, and validate decision-making processes. Knowledge Management works with data and information, using a knowledge representation that defines mechanisms for the set of entities' characteristics and behavior. Moreover, this component enables SI to plan actions and determine consequences by AI/ML and reasoning to direct action on the set of entities. In this context, this component handles which context and situation information is applied to the raw data, transforming it to information and then knowledge.

Assuming a UAV-based MC use case, UAVs can provide essential data about the context and situation. For example, object detection with AI/ML algorithms applied to videos from searching and rescuing areas can help locating victims. The AI/ML algorithms needed during the search stage may change from those required for diagnostic and rescue. For instance, assume that Deep Neural Networks (DNNs) are used for object detection [22], but the set of objects needs to be detected change over time. Therefore, SI needs to have Knowledge Management to fit different AI/ML algorithms loaded at UAVs for each context and situation. Moreover, UAVs can be positioned for providing connectivity in remote areas, being configured on-the-fly as repeaters, just amplifying the signals, or as a full Base Station (BS) [23]. In this case, Knowledge Management using context and situation information represented by estimated interference signals and coverage areas, can assist in the decision-making that regards choosing the better connectivity strategy for each MC service.

### *Context Awareness*

The Context Awareness component enables various data and information to be easily correlated and integrated with the other SI components. In this case, this component allows SI to provide customized services and resources corresponding to that context. This component's fundamental characteristic is to enable SI to adapt its behavior according to changes in the context. For example, the contextual history may be useful for driving policy decisions for current and future interactions. Moreover, context knowledge offers a greater level of reliability and usefulness over the whole systems.

SI must store data regarding the network, services, and users, such as the number of users and the bandwidth requested along with an MC. For example, it is possible to ensure that applications that benefit from low latency are prioritized over others with less importance. The data considered by Context Awareness is mandatory for instance, in SAR scenario that deals with the transmission of Control Signal (CS) to inform UAVs about the flight plan for an MC [24, 7] task, such as person identification or supply delivery.

### *Cognition Management*

This management allows SI to understand data and information input in the system, i.e., defining how these were produced. In this case, the component provides four functions: (i) perform inferences to generate new knowledge, (ii) change existing knowledge, (iii) use raw data and historical data to learn what is happening in a distinct context and situation, e.g., why the data were generated, and which components could be affected, and (iv) determine new actions to guarantee the goals of SI. Finally, the Cognition Management component uses these four functions to validate and generate new knowledge.

An MC service usually operates in dynamic scenarios regarding computation-communication trade-offs between the UAVs and network infrastructure. In this context, SI could provide Cognition Management to choose, change, and deploy placement strategies for the computational vision and VNFs, evaluating their effects on CPU and RAM usage. Moreover, all the changes over the configuration of systems and flight plans must be handled through their history to generate new knowledge.

### *Situational Awareness*

This component enables SI to understand what happened and how it influences the SI goals. This component works to know how and why the current situation presents such results. SI observes various situations evolving, examining them for patterns within each condition and between different cases. This observation process includes five actions: (i) collecting data, (ii) understanding the significance of this data, (iii) determining what to perform in response to a given event, (iv) making a decision, and (v) evaluating these actions. In this way, it enables the application of context and policies to a distinct situation using inference and historical data to learn what is happening in one specific context, why, and what should be done in response to it. It is essential to highlight the difference between Context Awareness and Situational Awareness. The first one describes the state and environment in which an entity exists. The second one incorporates contextual information and other inputs to understand the meaning of data and behavior of the entire assisted system and its operational environment.

One of UAV's essential applications in MC service is to provide a quick evaluation of the situation in SAR areas. UAVs promote versatility, fast response time, and capacity to support several services. Therefore, all this requires ability to learn about various evolving situations and examine patterns within each condition among different MC services. In this case, these services can allow Situational Awareness to keep predicting the situation's progression and how it affects the goals to achieve the MC task.

### *Model-Driven Engineering*

Model-Driven Engineering is an approach to software development where models are used to understand, design, implement, deploy, operate, maintain, and modify software systems. This component focuses on business logic, using an abstract methodology. Therefore, this model supports three essential purposes: (i) to ensure that several data models used in SI maintain a consistent definition and understanding of concepts, (ii) to enable different policies at various levels of abstraction to communicate with each other using a common vocabulary and data dictionary, and (iii) to develop from a specification of policy to its implementation.

The integration of several standards for supporting MC services, such as 3GPP 5GC, O-RAN, and ETSI MEC, demands software development models to provide abstraction levels and a shared vocabulary between external systems and SI. It is essential to define data models and APIs for supporting this integration among the standards. Moreover, another crucial feature of model-driven is to design different Access Point Name (APN) to direct users to various service networks, for example, to guarantee the connectivity of UAVs, vRAN, MEC, 5GC, and SI, to offer the better MC service.

### *Policy Management*

Policy Management provides uniform and intuitive mechanisms for providing consistent recommendations and commands to ensure the scalable decisions directing SI behavior. Three types of policies can be used in SI. The Imperative Policy uses statements to change the state of a set of targeted objects explicitly. Declarative Policy works based on ideas to describe what needs to be done without defining how to execute this task. The Intent Policy applies statements from a restricted natural language to express the policy's goals, but not how to accomplish these goals. SI can handle any combination of these policies to define recommendations and commands to support and manage the system.

An MC service is fundamental for controlling the network's behavior, applying security and control rules related to UAV's session management, mainly for functionalities associated with vRAN. This component should provide a mobility policy to add the control of access restrictions to MC services in a given area.

Moreover, the policy should include the management of topics associated with priority access to the channel of given UAV to others detriment. Furthermore, this management should provide metrics related to QoS and information regarding the data flow, which is obtained by regularly monitoring events, for example, considering the transmission bit rate on the partitioning strategy for the computational vision among UAVs, vRAN, MEC, and 5GC.

The next section presents experiments that aim at assessing specific aspects of using SI in MC scenarios. The description of a SI system working in a closed-loop, retrieving data, and imposing actions are out of this article's scope. However, the following section presents evidence using an actual testbed on how MC services performance can be improved via SI.

#### **4. Experiments with AI for UAV-Based SAR**

This section describes SAR experiments as a use case to make more concrete the discussion about the benefits of having SI in MC services. The goal of the experiments is twofold: (i) provide concrete examples of how SI orchestrating communications and AI/ML applications can positively impact MC services and (ii) demonstrate how open-source software and low-cost off-the-shelf equipment can be put together to assess essential issues related to AI/ML in 5G/B5G MC scenarios.

The 5G/B5G network is where SI can orchestrate tasks such as the placement of VNFs in different network elements. UAVs, for instance, can behave as UEs or BSs, under the control of SI. Regarding AI/ML, UAVs fly around a disaster area with equipment for performing computational vision (more specifically, object detection via DNNs). SI has the flexibility of distributing AI/ML processing among equipment in the cloud, edge, and UAVs themselves. This flexibility allows SI to trade-off energy consumption and latency, for instance. Motivated by a SAR situation in which the objects to be detected change along with the mission, it is assumed that SI can partition (split) the layers of a DNN into subsets and allocate distinct equipment to execute each subset of layers. For instance, the first layers of a convolutional DNN, which detect simpler features, can be kept fixed and executed by UAVs (acting as a UE). The last layers, which are specialized to the objects of interest, can be implemented by MEC (in vRAN or in the core) and continuously adapted according to the time evolution of the SAR mission.

The communication network used in the experiments is implemented in a testbed made available to promote reproducible results.<sup>2</sup> This testbed is based on the Ope-

---

<sup>2</sup><https://github.com/lasseufpa/connected-ai-testbed>

nAirInterface (OAI) software for vRAN deployment and the free5GC software to implement a Non-Standalone 5GC. These two elements are containerized with Docker, with automated deployment via Kubernetes. A summary of the hardware used to execute the main software components is presented in Table 2. The testbed employs Mininet to implement both the fronthaul and backhaul topology. Mininet allows emulating switches and routers in the transport network. In this case, the connection between vRAN and 5GC can have different network topologies and behaviors, e.g., different link latencies, bandwidths, and packet loss rates. Therefore, Mininet allows conveniently emulating edge or cloud scenarios along with the experiments, reproducing characteristics found in real scenarios. The automated Kubernetes cluster orchestration complements this flexibility. Moreover, this automation makes it easier to place 5GC and gNB VNFs (implemented as containers) according to the mobile network scenario defined in each experiment.

We implemented object detection with OpenCV and Pytorch. The layers of the adopted DNN were partitioned into two, and these subsets were executed by UAV (the first subset of layers) and a cloud or edge equipment (the second subset of layers). The DNN layers run by UAVs were processed by an NVIDIA Jetson Nano, as indicated in Table 2. This board has a quad-core ARM A57@1.43 GHz CPU, with 4 GB 64-bit LPDDR4 memory and a 128-core NVIDIA Maxwell GPU. Therefore, Jetson Nano represents a situation in which the UAV hardware may not execute the full DNN in real-time or the last layers change along with the mission.

Table 2: Testbed functionalities with associated hardware and software

Function	CPU	RAM	Software
UPF, AMF, HSS, SMF, PCRF (5GC)	i5-7500	8 GB	Free5GC
RCC (vRAN)	i5-7500	8 GB	OpenAirInterface
RRH (vRAN)	i5-7500	8 GB	OpenAirInterface
Backhaul	i5-7500	8 GB	Mininet
UAV (Jetson Nano)	A57	4 GB	Pytorch, OpenCV

We devised two sets of experiments. The first concerns evaluating the impact of having SI splitting the execution of a DNN between a UAV (as UE) and MEC (in vRAN, i.e., in edge). The second set of experiments regards vRAN slicing and VNF placement, which we assume to be also orchestrated by SI. In both cases, SI is not fully implemented in a closed-loop. Instead of automatically acting according to its inputs, some configurations regarding AI/ML and VNF placement are manually defined and interpreted as SI actions. This configuration simplifies the experiments and their description. A fully working SI is out of this article's

scope and will be described in future work. We describe the two sets of experiments and their results in the following.

#### 4.1. *Distributed AI/ML*

Factors such as computational resources, energy consumption, and latency must be considered for real-time image understanding through AI/ML techniques when UAVs capture visual information in MCs. These aspects should be addressed by analyzing the computational cost usage through splitting the processing between the UAV and other processing units. For this set of experiments, an SSD-VGG16 DNN was trained to detect four classes: person, car, bicycle, and motorcycle. The adopted dataset was UFPark, described by Nascimento et al. [25], which consists of videos recorded in a campus parking lot. When datasets with videos recorded from UAVs are available, it will be interesting to compare the performance with models trained with videos obtained from fixed cameras, as adopted in this work.

The original video resolution was subsampled to  $300 \times 300$  pixels with three color channels, and the DNN input is a frame of this video. The trained DNN had 40 layers and  $24.15 \times 10^6$  parameters (weights), each represented with 32 bits. DNN was split into two subsets of layers according to three configurations. In the first configuration, UAV executed from the first to the third layer. Therefore, the quantized scores (activation values) of this third layer were sent through the network, and a cloud or edge equipment executed the remaining 37 layers. The other two configurations adopted splits after the sixth and tenth layers, respectively. Figure 5 depicts the results for these three configurations concerning the average number of Frames per Second (FPS) (bottom) and the latency (top), considering the time to execute both subsets of DNN layers and the time to transmit the data in the uplink from UAV to the edge or cloud equipment.

The results in Figure 5 explore three different split configurations in both edge and cloud scenarios, and identify that, in this case, it is beneficial to have 10 DNN layers processed by UAV. In contrast, the remaining 30 layers are processed at the edge or cloud. These scenarios need to assess QoS measures and adapt the applications running through the transport network indicates that SI can improve MC services by properly orchestrating communication aspects and also the AI/ML applications.

#### 4.2. *RAN slicing and VNF placement*

SAR and other MC scenarios require communication networks that maximize the probability of successful mission completion. As indicated by the previous experiments, orchestrating AI/ML applications can bring significant advantages in realistic situations. Therefore, we now illustrate how SI can optimize the network for improved robustness to the MC services. In this set of experiments, the SI



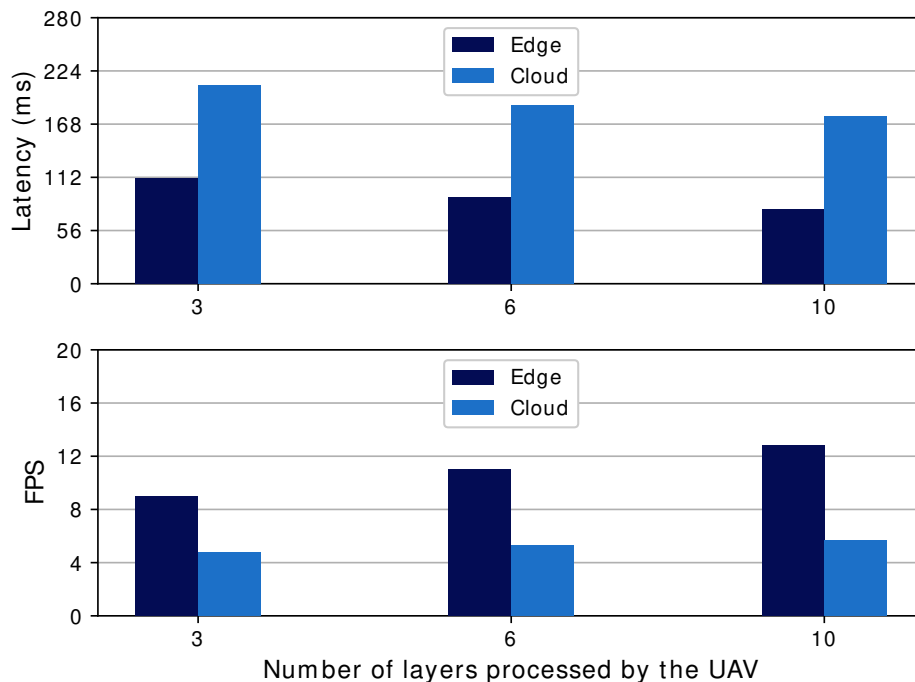

Figure 5: Performance of AI/ML application using different splits of a DNN between UAV and a terrestrial equipment at edge or cloud.

system is assumed to orchestrate VNFs and manage radio resources to attend two distinct sets of requirements, imposed by applications running on UAV (as UE) and three traditional UEs (e.g., smartphones), respectively. These four devices are connected to a BS using Long Term Evolution (LTE) with a bandwidth of 5 MHz for downlink, which corresponds to a total rate of approximately 18 Mbps to be distributed among the connected devices.

UAV executes an MC service for the SAR mission that requires a constant bit rate of 13 Mbps. The other UEs are requesting 5 Mbps each, for applications that are not critical. We contrast two situations: (a) SI imposes a strategy based on vRAN slicing to protect the UAV communication versus (b) fair scheduling without such vRAN slicing. Figure 6 shows these two situations via the throughput values for UAV and the three traditional UEs' accumulated rates. Moreover, the UAV application does not reach the required 13 Mbps, considering the scenario without vRAN slicing (circle markers). When considering the SI-driven scenario using vRAN slicing (x markers), the slice exclusively created for UAV can guarantee

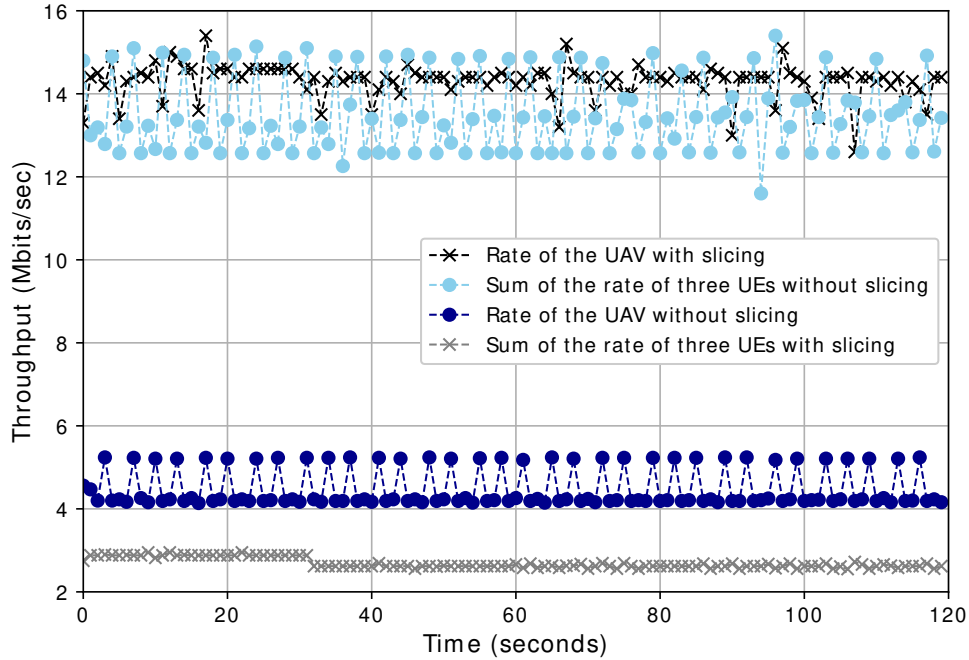

Figure 6: Throughput in RAN slicing experiment.

the 13 Mbps target. In this case, the three traditional UEs only have access to the remaining radio resources, which are equally distributed among them.

In Figure 7, the curves contrast the results with and without slicing but concerning latency between UAV and equipment at the edge or cloud that is serving UAV data. This scenario considers that the same devices of the previous vRAN slicing experiment are connected to the network and request the same throughput. The application server and 5GC (with VNFs, such as UPF and AMF) are either located at the edge or cloud. For emulating the transport network in the cloud scenario, Mininet was used to impose a backhaul topology with a total latency of 100 ms. Moreover, the curves in Figure 7 show the effect of both actions: vRAN slicing and VNF placement. VNF allocations on edge provide better latency values than allocating at the cloud. Furthermore, vRAN slicing reduces the latency value experienced by UAV in both edge and cloud scenarios. Overall, the results indicate the impact of SI actions in guaranteeing SAR demands related to throughput and latency.

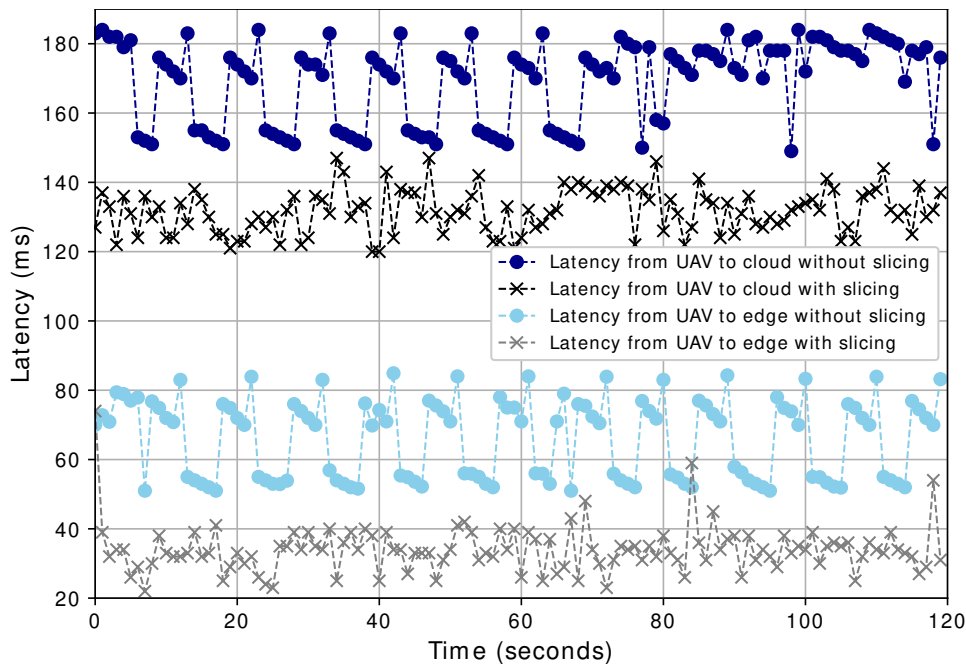

Figure 7: Latency when using RAN slicing and VNF placement.

## 5. Related Work Regarding UAV-Based MC

Previously, mainly in Section 2, we reviewed existing academic articles and standards to contextualize the proposed SI. In this section, we complement the literature overview by focusing on a non-exhaustive list of recent manuscripts that discuss integrating the main elements of AI/ML-based MC services, eventually using UAVs. As discussed, MC applications (e.g., SAR) must be supported by telecommunication infrastructures, considering many elements of vRAN, edge, core, and even cloud [26]. In this context, one can observe the great attention of academia and industry for the utilization of UAVs in SAR [27]. The following paragraphs provide information on how these elements can be put together and help understand the proposed SI' relations with previous works.

Besides the mentioned communication infrastructure elements, many MC applications rely on computational vision [8]. The performance of MC applications such as SAR can be largely improved by considering AI/ML, edge, and multi-UAV technologies together [26]. Aligned with this perspective, two recent surveys were published [28, 22]. Xu et al. [28] discussed concepts that allow the distinction between Edge Intelligence and Intelligent Edge. For the authors, Edge Intelligence

focuses on intelligent applications in the edge environment with edge computing assistance and protection of users' privacy. On the other hand, Intelligent Edge aims to solve edge computing problems using AI solutions, e.g., resource allocation optimization. Moreover, Wang et al. [22] emphasize that Edge Intelligence seeks to facilitate Deep Learning (DL) services via edge computing. Furthermore, DL can be integrated into edge computing frameworks to build an Intelligent Edge for dynamic, adaptive edge maintenance and management. Finally, the authors discuss the challenges regarding Edge intelligence and Intelligent Edge. The main requirement is to design a complete system framework covering data acquisition, service deployment, and the placement of AI/ML models considering processing and network resources.

Pham et al. [7] introduced an article presenting the research on the integration of MEC with 5G and beyond. The authors discuss MEC for UAV communication and the integration between 5GC and vRAN. The authors explain how UAVs can improve wireless communications, providing cost-effective, fast, flexible, and efficient deployments. Moreover, UAVs can provide on-the-fly communications and establish Line-of-Sight (LoS) communication links to users in a complementary network for SAR emergencies and disaster reliefs. In this context, Pham et al. [7] describe two typical scenarios integrating UAV and MEC. An application considers UAVs operating as aerial users of the cellular-connected network. In this case, the MEC server-based BS can provide seamless and reliable wireless communications for UAVs to improve computation performance. Another application refers to UAVs working as aerial BSs and equipped with a MEC server. Therefore, MEC-enabled UAV servers give opportunities for mobile users to offload heavy computation tasks. Finally, the authors highlight several challenges integrating UAV with the MEC system, such as mobility control and trajectory optimization, communication and computation resource optimization, energy-aware resource allocation, and user grouping and UAV association.

Specifically, about SAR as an MC task, Queralta et al. [2] show the research efforts within the AutoSOS project. This project designs an autonomous multi-robot SAR assistance platform using AI models for object detection. The platform operates in the reconnaissance missions over the sea by executing adaptive DL algorithms in UAVs and boats. Moreover, UAVs can autonomously reconfigure their spatial arrangement to allow multi-hop communication, for example, when a direct connection between a UAV transmitting information and the vessel is unavailable. This reconfiguration uses algorithms for autonomous decision-making at the edge devices, i.e., UAVs, considering independent task migration and communication priority decisions within the multi-UAV system. In this context, the authors discuss the need to integrate a single multi-agent control loop using DL techniques for advanced vision, communication constraints, spatial awareness, and computation

distribution. Moreover, Queralta et al. highlight that this integration cannot require high computational resources since a UAV’s low energy consumption is needed to increase its autonomy.

Table 3: Related work involving UAVs assisted by AI/ML and focused on MC services over 5G/B5G infrastructures

Article	Multi UAV	Edge	AI	5GC	MEC	vRAN	Cloud	MC Services
[28]		✓	✓				✓	
[22]		✓	✓		✓		✓	
[7]	✓	✓	✓	✓	✓	✓	✓	✓
[2]	✓	✓	✓					✓
[29]	✓		✓		✓	✓		

Glimpsing a 6th Generation (6G) network, Zhang et al. [29] propose a UAV-to-Everything (U2X) communication framework. The authors argue that UAVs are unsuited for achieving a high data rate by directly connecting the terrestrial cellular networks. Therefore, the authors apply three techniques for U2X communications: cooperative sensing and transmission protocol, UAV trajectory design, and radio resource management considering vRANs. Together, they provide a feasible architecture for UAV sensing utilization in the 6G network. Moreover, the authors discuss the open problems of U2X communications, such as UAV Cooperation with U2X Communications to reduce the cost of power and spectrum resources, as well as MEC with U2X Communications to minimize the computation workload of the base station and to improve QoS.

We summarize this short sample of the state-of-the-art in Table 3, which indicates the fundamental elements for supporting UAV-based critical missions considered in each article, such as Multi-UAV, edge, AI, MEC, vRAN, cloud, and MC services. According to our literature review, the manuscripts do not discuss the integration of all elements that concern the proposed SI. However, the literature clearly indicates the trend towards an intelligent global system with a cognitive control loop using AI/ML techniques.

## 6. Conclusion and Future Work

Standardization and wide adoption of AI/ML are key strategies to reach scale, reduce cost, and achieve MC services efficiency that heavily depends on communication and computing systems. UAVs significantly contribute to improving MC

services but demand standards and efficient AI/ML for optimized performance. In this article, we presented SI, an architecture for providing full AI/ML capabilities for standardized systems supporting MC services. In addition to describing the whole architecture and its interaction with the assisted system, we also presented experiments that illustrate SI benefits. The initial results show the challenges imposed in some search and rescue scenarios while also offering the potential gains obtained with the introduction of SI.

The described experiments are timely for researching 6G and future generation computer systems because the current state-of-the-art in UAV-based has not yet found the requirements for MC tasks, such as the timeliness of data processing. The present research seeks solutions to how UAV can improve their sensing range and how UAVs can become more intelligent through cooperation. Aspects such as delays need to be taken into account, and simulators are rather limited concerning mimicking all variability found in critical missions.

While the experiments of this article exercised some of the essential components of SI architecture, implementing this software that covers all its components is still lacking. Therefore, as future work, we intend to develop and publicly available a functional implementation of SI that minimally illustrates all components. Given the size and complexity of this task, we plan to perform it in phases. Each one is complemented by additional use cases that illustrate the components involved and the benefits obtained. Additionally, we are interested in investigating how to evolve the AI/ML awareness level of assisted systems. For example, the necessary changes to turn MEC at least AI/ML basic-aware and turn 5G core AI/ML advanced-aware. In this context, the concept of ML pipeline introduced by the specification ITU-T Y.3172 seems a promising approach for adding awareness to assisted systems.

## **Acknowledgment**

This article was conducted with partial financial support from the National Council for Scientific and Technological Development (CNPq) under grant number 130555/2019-3.

## **References**

- [1] A. Iwasaki, T. Noda, A framework for quantifying the relationship between intensity and severity of impact of disturbance across types of events and species, *Scientific Reports* 8 (2018) 1–7.

- [2] J. P. Queralta, et al., AutoSOS: Towards Multi-UAV Systems Supporting Maritime Search and Rescue with Lightweight AI and Edge Computing, *CoRR* abs/2005.03409 (2020). URL: <https://arxiv.org/abs/2005.03409>.
- [3] L. Bonati, et al., Open, Programmable, and Virtualized 5G Networks: State-of-the-Art and the Road Ahead, *Computer Networks* 182 (2020) 107516.
- [4] 3GPP-TR21.915, Technical Specification Group Services and System Aspects; Release 15 Description, Technical Report, 3rd Generation Partnership Project (3GPP), 2018-12. Version 0.5.0.
- [5] 3GPP-TR21.916, Technical Specification Group Services and System Aspects; Release 16 Description, Technical Report, 3rd Generation Partnership Project (3GPP), 2020-09. Version 0.6.0.
- [6] M. Mozaffari, et al., A Tutorial on UAVs for Wireless Networks: Applications, Challenges, and Open Problems, *IEEE Communications Surveys & Tutorials* 21 (2019).
- [7] Q. Pham, et al., A Survey of Multi-Access Edge Computing in 5G and Beyond: Fundamentals, Technology Integration, and State-of-the-Art, *IEEE Access* 8 (2020) 116974–117017.
- [8] C. Dario, et al., A Survey of Computer Vision Methods for 2D Object Detection from Unmanned Aerial Vehicles, *Journal of Imaging* 6 (2020) 78–116.
- [9] R. Shafin, et al., Artificial Intelligence-Enabled Cellular Networks: A Critical Path to Beyond-5G and 6G, *IEEE Wireless Communications* 27 (2020) 212–217.
- [10] Y. Wang, et al., From Design to Practice: ETSI ENI Reference Architecture and Instantiation for Network Management and Orchestration Using Artificial Intelligence, *IEEE Communications Standards Magazine* 4 (2020) 38–45.
- [11] A. Ghosh, et al., 5G Evolution: A View on 5G Cellular Technology Beyond 3GPP Release 15, *IEEE Access* 7 (2019) 127639–127651.
- [12] D. Sabella, et al., ETSI White Paper No. 20 - Developing Software for Multi-Access Edge Computing, Technical Report, European Telecommunications Standard Institute (ETSI), 2019.

- [13] S. Kekki, et al., ETSI White Paper No. 28 – MEC in 5G networks, Technical Report, European Telecommunications Standards Institute (ETSI), 2018.
- [14] M. Azmat, S. Kummer, Potential applications of unmanned ground and aerial vehicles to mitigate challenges of transport and logistics-related critical success factors in the humanitarian supply chain, *Asian Journal of Sustainability and Social Responsibility* 5 (2020) 1–22.
- [15] M. Hossain, et al., Integration of smart watch and geographic information system (GIS) to identify post-earthquake critical rescue area part. i. development of the system, *Progress in Disaster Science* 7 (2020) 100116.
- [16] D. Orfanus, E. P. de Freitas, F. Eliassen, Self-organization as a supporting paradigm for military UAV relay networks, *IEEE Communications Letters* 20 (2016) 804–807.
- [17] B. Li, Z. Fei, Y. Zhang, UAV communications for 5G and beyond: Recent advances and future trends, *IEEE Internet of Things Journal* 6 (2018) 2241–2263.
- [18] Z. Qadir, et al., Addressing disasters in smart cities through UAVs path planning and 5G communications: A systematic review, *Computer Communications* (2021).
- [19] A. A. Alsaedy, E. K. Chong, 5G and UAVs for Mission-Critical Communications: Swift Network Recovery for Search-and-Rescue Operations, *Mobile Networks and Applications* 25 (2020) 2063–2081.
- [20] P. Safety, Homeland Security, “2017 Atlantic hurricane season impact on communications,”, Technical Report, Tech. Rep., 2018. <https://docs.fcc.gov/public/attachments/DOC-353805A1.pdf>, 2018.
- [21] J. Strassner, et al., ETSI GS ENI 005 V1.1.1 (2019-09) – Experiential Networked Intelligence (ENI); System Architecture, Technical Report, European Telecommunications Standard Institute (ETSI), 2019.
- [22] X. Wang, et al., Convergence of Edge Computing and Deep Learning: A Comprehensive Survey, *IEEE Communications Surveys Tutorials* 22 (2020) 869–904.
- [23] M. Moradi, et al., Skycore: Moving Core to the Edge For Untethered and Reliable UAV-Based LTE Networks, *GetMobile: Mobile Computing and Communications* 23 (2019) 24–29.



- [24] 3GPP-TR22.829, Technical Specification Group Services and System Aspects; Enhancement for Unmanned Aerial Vehicles; Technical Report Stage 1 (Release 17), Technical Report, 3rd Generation Partnership Project (3GPP), 2019-09.
- [25] I. Nascimento, et al., Public dataset of parking lot videos for computational vision applied to surveillance, in: 19th IEEE International Conference On Machine Learning And Applications (ICMLA) (Accepted for publication), 2020.
- [26] T. Klamt, et al., Flexible Disaster Response of Tomorrow: Final Presentation and Evaluation of the CENTAURO System, IEEE Robotics Automation Magazine 26 (2019) 59–72.
- [27] W. Shule, et al., UWB-Based Localization for Multi-UAV Systems and Collaborative Heterogeneous Multi-Robot Systems, Procedia Computer Science 175 (2020) 357–364.
- [28] D. Xu, et al., Edge Intelligence: Architectures, Challenges, and Applications, 2020. <https://arxiv.org/abs/2003.12172>.
- [29] S. Zhang, H. Zhang, L. Song, Beyond D2D: Full Dimension UAV-to-Everything Communications in 6G, 2020. <https://arxiv.org/abs/2004.01920>.