



uniformly accelerated observer. In Section III, we discuss the notion of vacuum entanglement between independent regions of spacetime, before reviewing the quantum circuit model and the self-homodyne detection technique for the inertial observer in Section IV. In Section V, we present analytic results for the purity of output states according to the inertial Minkowski observer. We conclude with some final remarks and opportunities for further research.

## II. CONTINUOUS-VARIABLE TELEPORTATION BETWEEN INERTIAL OBSERVERS

Quantum teleportation describes the transfer of an unknown quantum state  $\hat{\rho}_{\text{in}}$  between distant observers using a classical channel and a pre-existing entanglement resource [24]. Whilst originally formulated using entangled Bell pairs as the resource, a continuous-variable version of the protocol was first introduced by Vaidman in [25] and then by Braunstein and Kimble in [26]. We follow the all-optical approach in [27], where the classical channel is enacted via the direct transmission of a classical field wherein the conjugate quadrature operators of the field are largely amplified above the quantum noise limit (QNL). The quantum channel involves the distribution of an entangled bi-partite system between the observers. By performing appropriate local operations on their entangled system, the receiver can retrieve an arbitrarily good version of the initial state  $\hat{\rho}_{\text{in}}$  without any quantum information being directly transmitted. For our purposes, the utility of this approach is that the evolution of field modes can be modelled as unitary operations.

Consider the diagram shown in Fig. 1. A pair of EPR-entangled field modes is distributed between two distant observers, Rob and Charlie. Rob, operating a linear optical amplifier, mixes the input mode  $\hat{a}_{\text{in}}$  with the entangled vacuum mode  $\hat{a}_i$  and transmits the output field  $\hat{a}_{\text{ch.}}$  to Charlie. For a sufficiently large gain  $\mathcal{G}$ , the conjugate quadrature operators  $\hat{X}_{\text{ch.}}^+$ ,  $\hat{X}_{\text{ch.}}^-$  have uncertainties much larger than the quantum limit of unity. Hence, the quantum noise introduced by a joint measurement of  $\hat{X}_{\text{ch.}}^+$ ,  $\hat{X}_{\text{ch.}}^-$  is negligible compared to the already amplified quadrature amplitudes, allowing for the designation of  $\hat{a}_{\text{ch.}}$  as a classical field [27]. Charlie receives  $\hat{a}_{\text{ch.}}$  and mixes it at a beamsplitter with the other half of the entanglement resource,  $\hat{a}_j$ . By attenuating  $\hat{a}_{\text{ch.}}$  by  $1/\mathcal{G}$  and then considering the limit of perfect entanglement between the vacuum modes  $\hat{a}_i$  and  $\hat{a}_j$ , Charlie is able to retrieve the input mode  $\hat{a}_{\text{in}}$ .

To illustrate this mathematically, consider the evolution of the bosonic operator  $\hat{a}_{\text{in}}$  through the teleportation protocol, given in the Heisenberg picture by

$$\hat{a}_{\text{out}} = \hat{S}_2^\dagger(r) \hat{U}_{\text{BS}}^\dagger(\eta) \hat{a}_{\text{in}} \hat{U}_{\text{BS}}(\eta) \hat{S}_2(r) \quad (1)$$

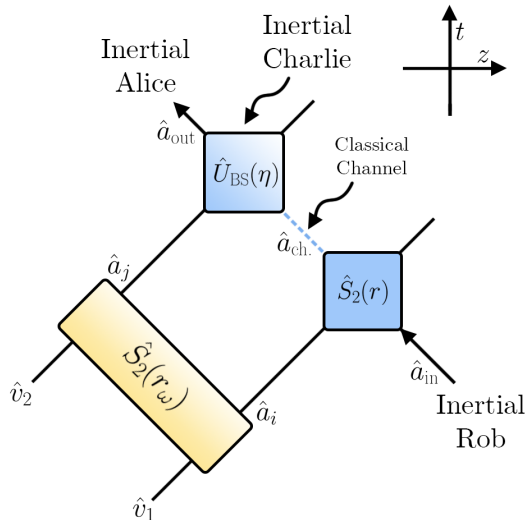

FIG. 1: The all-optical teleportation protocol between inertial observers. Bob prepares an unknown state in the mode  $\hat{a}_{\text{in}}$  and mixes it at a linear optical amplifier (modelled by a two-mode squeezing unitary) with one half of an EPR-entangled field mode,  $\hat{a}_i$ . The amplification of the input state generates an effective classical channel between Rob and Charlie, who combines  $\hat{a}_{\text{ch.}}$  with the other half of the EPR pair at a beamsplitter. If Charlie tunes  $\eta$  appropriately, Alice can receive a perfect reconstruction of  $\hat{a}_{\text{in}}$ , in the limit of high entanglement.

where

$$\hat{S}_2(r) = \exp [\xi^* \hat{a}_i \hat{a}_{\text{in}} - \xi \hat{a}_{\text{in}}^\dagger \hat{a}_i^\dagger] \quad (2)$$

$$\hat{U}_{\text{BS}}(\eta) = \exp [i\theta (e^{i\phi} \hat{a}_{\text{in}} \hat{a}_j + e^{-i\phi} \hat{a}_{\text{in}}^\dagger \hat{a}_j^\dagger)]. \quad (3)$$

$\hat{S}_2(r)$  is a unitary two-mode squeezing operator with amplitude  $\xi = r e^{i\alpha}$ , describing the linear amplification of  $\hat{a}_{\text{in}}$  mixed with  $\hat{a}_i$ , whilst  $\hat{U}_{\text{BS}}(\eta)$  represents the beamsplitter interaction performed by Charlie. Recalling that in the Heisenberg picture, operators act on the modes in reversed temporal order, we have:

$$\hat{a}_{\text{out}} = \hat{S}_2^\dagger(r) (\sqrt{\eta} \hat{a}_{\text{in}} - \sqrt{1-\eta} \hat{a}_j) \hat{S}_2(r) \quad (4)$$

$$= \sqrt{\eta} \hat{S}_2^\dagger(r) \hat{a}_{\text{in}} \hat{S}_2(r) - \sqrt{1-\eta} \hat{a}_j, \quad (5)$$

where we have used the substitution  $\eta = \cos^2 \theta$ . Now,  $\hat{S}_2^\dagger(r) \hat{a}_{\text{in}} \hat{S}_2(r)$  imitates the linear amplification of the field quadratures of  $\hat{a}_{\text{in}}$  mixed with  $\hat{a}_i$  for  $r \gg 1$ , acting as the classical channel between Rob and Charlie:

$$\hat{a}_{\text{out}} = \underbrace{\sqrt{\eta} \cosh r \hat{a}_{\text{in}} + \sqrt{\eta} \sinh r \hat{a}_i^\dagger}_{\hat{a}_{\text{ch.}}} - \sqrt{1-\eta} \hat{a}_j. \quad (6)$$

It can also be regarded as a joint, continuous-variable measurement of the quadrature operators for  $\hat{a}_{\text{in}}$  and  $\hat{a}_i$ . Then, by taking the attenuation of Charlie's beamsplitter

to be  $\eta = (\cosh r)^{-2}$ ,  $\hat{a}_{\text{out}}$  reduces to,

$$\hat{a}_{\text{out}} = \hat{a}_{\text{in}} + \hat{a}_i^\dagger \tanh r - \hat{a}_j \sqrt{1 - (\cosh r)^{-2}}. \quad (7)$$

In the limit  $r \gg 1$ , Eq. 7 becomes

$$\hat{a}_{\text{out}} \simeq \hat{a}_{\text{in}} + \hat{a}_i^\dagger - \hat{a}_j, \quad (8)$$

implying that the output state is polluted by two additional QNL from  $\hat{a}_i, \hat{a}_j$ . Recall however that  $\hat{a}_i$  and  $\hat{a}_j$  are highly correlated via two-mode squeezing of the vacuum state, related by

$$\hat{a}_i = \hat{S}_2^\dagger(r_\omega) \hat{v}_1 \hat{S}_2(r_\omega) = \hat{v}_1 \cosh r_\omega + \hat{v}_2^\dagger \sinh r_\omega \quad (9)$$

$$\hat{a}_j = \hat{S}_2^\dagger(r_\omega) \hat{v}_2 \hat{S}_2(r_\omega) = \hat{v}_2 \cosh r_\omega + \hat{v}_1^\dagger \sinh r_\omega, \quad (10)$$

where  $r_\omega$  is the squeezing amplitude. Expressing  $\hat{a}_i^\dagger$  and  $\hat{a}_j$  in terms of  $\hat{v}_1, \hat{v}_2$  yields

$$\hat{a}_{\text{out}} = \hat{a}_{\text{in}} + (\cosh r_\omega - \sinh r_\omega) (\hat{v}_1^\dagger - \hat{v}_2). \quad (11)$$

In the limit of perfect entanglement between  $\hat{a}_i, \hat{a}_j$  ( $r_\omega \rightarrow \infty$ ), then

$$\hat{a}_{\text{out}} = \hat{a}_{\text{in}}. \quad (12)$$

In this limit, the effective channel between the input and output is the identity. This protocol can be classified as quantum teleportation because the only direct link between the input and output is the classical channel through which the highly amplified field propagates [27].

### III. VACUUM ENTANGLEMENT IN (1+1)-DIMENSIONAL QUANTUM FIELD THEORY

We now review the entanglement structure of the vacuum state in (1+1)-dimensional quantum field theory. Consider a massless, scalar field  $\hat{\Phi}$  which can be expanded in a plane wave basis, given by

$$\hat{\Phi}(U, V) = \int dk (\hat{a}_{kl} u_k(V) + \hat{a}_{kr} u_k(U) + \text{h.c}), \quad (13)$$

where h.c denotes the Hermitian conjugate, and  $u_{kl}(u_{kr})$  are left-moving (right-moving) single frequency mode functions [22]

$$u_k(V) = \frac{1}{\sqrt{4\pi k}} e^{-ikV} \quad (14)$$

$$u_k(U) = \frac{1}{\sqrt{4\pi k}} e^{-ikU}, \quad (15)$$

where  $V = t + z$  and  $U = t - z$  are Minkowski light-cone co-ordinates and  $k$  is the frequency of the mode with respect to  $t$ . The single-frequency Minkowski operators  $\hat{a}_{kl}(\hat{a}_{kr})$  and  $\hat{a}_{kl}^\dagger(\hat{a}_{kr}^\dagger)$  satisfy standard bosonic commutation relations,  $[\hat{a}_{ki}, \hat{a}_{k'i'}^\dagger] = \delta_{i,i'} \delta(k - k')$  and

$[\hat{a}_{ki}, \hat{a}_{k'i'}] = 0$ , where  $i = l, r$  denotes the directionality. The single-frequency Unruh operators  $\hat{c}_\omega, \hat{d}_\omega$  are related to the Minkowski operator by

$$\hat{a}_{kl} = \int d\omega (A_{k\omega} \hat{c}_{\omega l} + \hat{B}_{k\omega} \hat{d}_{\omega l}) \quad (16)$$

$$\hat{a}_{kr} = \int d\omega (B_{k\omega} \hat{c}_{\omega r} + \hat{A}_{k\omega} \hat{d}_{\omega r}), \quad (17)$$

where

$$A_{k\omega} = B_{k\omega}^* = \frac{i\sqrt{\sinh(\pi\omega/a)}}{2\pi\sqrt{\omega k}} \Gamma(1 - i\omega/a) \left(\frac{k}{a}\right)^{i\omega/a} \quad (18)$$

are the Bogoliubov transformation coefficients. The Unruh operators are a stepping stone between the Rindler and Minkowski operators.

#### A. Rindler Wedges, Coordinates and Operators

Minkowski spacetime can be partitioned into four wedges denoted (R), (L), (F) and (P), representing the right and left Rindler wedges and the future and past light cones respectively (see Fig. 2) [22]. Co-ordinates in

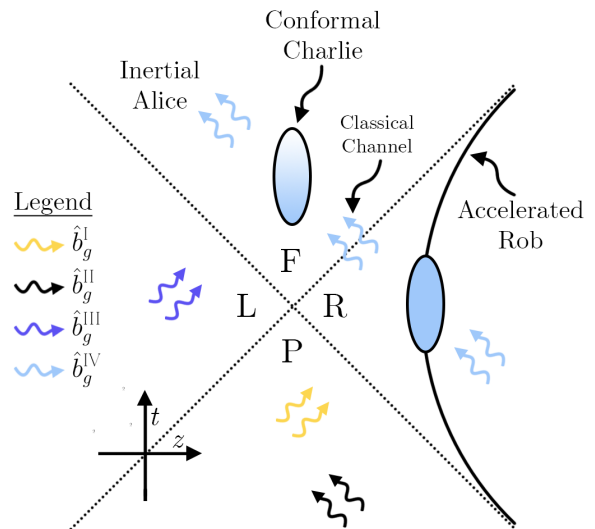

FIG. 2: Rob, accelerating uniformly in the right Rindler wedge, interacts with Rindler wavepacket modes,  $\hat{b}_g^{IV}$  and  $\hat{b}_g^I$  (blue ellipse). The classical channel is sent to the conformal receiver Charlie, mixing it with the right-moving Rindler modes  $\hat{b}_g^{III}$  at a beamsplitter (graded ellipse), before transmitting the state to Alice, in the Minkowski vacuum. The details of the unitary evolution of the Rindler modes is shown in Fig. 3.

these wedges are defined as follows,

$$(F) \begin{cases} t = a^{-1}e^{a\eta} \cosh(a\zeta) \\ z = a^{-1}e^{a\eta} \sinh(a\zeta) \end{cases} \quad (19)$$

$$(P) \begin{cases} t = -a^{-1}e^{a\bar{\eta}} \cosh(a\bar{\zeta}) \\ z = -a^{-1}e^{a\bar{\eta}} \sinh(a\bar{\zeta}), \end{cases} \quad (20)$$

where  $\eta, \bar{\eta}$  and  $\zeta, \bar{\zeta}$  are the conformal time and spatial co-ordinates of observers restricted to the (F) and (P) light-cones respectively, and

$$(R) \begin{cases} t = a^{-1}e^{a\xi} \sinh(a\tau) \\ z = a^{-1}e^{a\xi} \cosh(a\tau) \end{cases} \quad (21)$$

$$(L) \begin{cases} t = -a^{-1}e^{a\bar{\xi}} \sinh(a\bar{\tau}) \\ z = -a^{-1}e^{a\bar{\xi}} \cosh(a\bar{\tau}), \end{cases} \quad (22)$$

where  $\tau, \bar{\tau}$  and  $\xi, \bar{\xi}$  are the proper time and the spatial co-ordinates of a uniformly accelerated observer with proper acceleration  $a$  in the (R) and (L) wedge respectively. In Fig. 2, the conformal receiver Charlie is stationary according to an inertial observer but operates a beamsplitter with time-dependent reflectivity. Specifically, Olson et al. demonstrated in [8] that an Unruh-deWitt detector whose energy gap is scaled continuously as  $1/at$  responds to the Minkowski vacuum identically to one on an accelerated trajectory with fixed energy gap. By using an analogously time-dependent, mode-selective beamsplitter, Charlie remains in the causal future of Rob, who is uniformly accelerating, but can still interact with the same modes as him. This proceeds by analytically extending the (left-moving) Rindler mode functions in (R) into (P).

To see this, it is useful to introduce the Rindler analogues to the light-cone co-ordinates, given by

$$(F) \nu = \eta + \zeta \quad \mu = \eta - \zeta \quad (23)$$

$$(P) \bar{\nu} = -\bar{\eta} - \bar{\zeta} \quad \bar{\mu} = -\bar{\eta} + \bar{\zeta} \quad (24)$$

$$(R) \chi = \tau + \xi \quad \kappa = \tau - \xi \quad (25)$$

$$(L) \bar{\chi} = -\bar{\tau} - \bar{\xi} \quad \bar{\kappa} = -\bar{\tau} + \bar{\xi}. \quad (26)$$

In the reference frame of a uniformly accelerated observer, the field operator can be expanded in Rindler modes confined to the (R) and (L) wedges of spacetime

$$\hat{\Phi}(U, V) = \sum_{X=R,L} \int d\omega (\hat{b}_{\omega l}^X g_{\omega l}^X + \hat{b}_{\omega r}^X g_{\omega r}^X + \text{h.c.}) \quad (27)$$

where  $\omega$  is the frequency defined with respect to the proper time co-ordinate in the respective quadrant of Rindler space and X denotes the region over which  $\hat{b}_{\omega}$  has support. Equivalently,  $\hat{\Phi}$  can be expanded in the modes restricted to the future (F) and past (P). For example, the left-moving mode functions are

$$g_{\omega l}^R(\chi) = (4\pi\omega)^{-1/2} e^{-i\omega\chi} \quad (28)$$

$$g_{\omega l}^L(\bar{\chi}) = (4\pi\omega)^{-1/2} e^{-i\omega\bar{\chi}} \quad (29)$$

with their analogues in the future and past, given by,

$$g_{\omega l}^F(\nu) = (4\pi\omega)^{-1/2} e^{-i\omega\nu} \quad (30)$$

$$g_{\omega l}^P(\bar{\nu}) = (4\pi\omega)^{-1/2} e^{-i\omega\bar{\nu}}. \quad (31)$$

It can be easily shown that

$$g_{\omega l}^R(V) = g_{\omega l}^F(V) = (4\pi\omega)^{-1/2} (aV)^{-i\omega/a} \Theta(V) \quad (32)$$

$$g_{\omega l}^L(V) = g_{\omega l}^{P,\alpha}(V) = (4\pi\omega)^{-1/2} (-aV)^{i\omega/a} \Theta(-V). \quad (33)$$

Because  $g_{\omega l}^R(\chi)$  and  $g_{\omega l}^F(\nu)$  are identical as functions of  $V$ , as are  $g_{\omega l}^L(\chi)$  and  $g_{\omega l}^P(\nu)$ , the Bogoliubov coefficients relating the Minkowski and Rindler modes in (R) and (L) are duplicated in (F) and (P). Therefore the Rindler modes can be extended across the Rindler horizons by a change of co-ordinates. Using this property, one can define left-moving modes which span the entirety of Regions II and IV in Minkowski spacetime [8, 28], with their corresponding bosonic operators given by

$$\hat{b}_{\omega}^{\text{II}} := \hat{b}_{\omega l}^{\text{P}} = \hat{b}_{\omega l}^{\text{L}}, \quad (34)$$

$$\hat{b}_{\omega}^{\text{IV}} := \hat{b}_{\omega l}^{\text{R}} = \hat{b}_{\omega l}^{\text{F}}, \quad (35)$$

which have support over the entirety of Region II and IV (see Fig 2). For completeness, the following association for the right-moving Rindler operators can also be made

$$\hat{b}_{\omega}^{\text{I}} := \hat{b}_{\omega r}^{\text{L}} = \hat{b}_{\omega r}^{\text{F}} \quad (36)$$

$$\hat{b}_{\omega}^{\text{III}} := \hat{b}_{\omega r}^{\text{P}} = \hat{b}_{\omega r}^{\text{R}}. \quad (37)$$

Thus, the left-moving sector of the field can be expanded as follows [28]

$$\hat{\Phi}(V) = \sum_{\sigma=\text{II,IV}} \int_0^{\infty} d\omega (\hat{b}_{\omega l}^{\sigma} g_{\omega l}^{\sigma}(V) + \text{h.c.}). \quad (38)$$

Demonstrating the presence of entanglement between the left-moving modes in II and IV (analogously the right-moving modes in I and III) is identical to the derivation for space-like entanglement between (R) and (L) with a mere change of labels: that is, (P), (L)  $\Rightarrow$  II and (R), (F)  $\Rightarrow$  IV (for the right-movers, replacing (P), (R)  $\Rightarrow$  I and (L), (F)  $\Rightarrow$  III) [3, 8, 28]. This derivation is shown in detail in [8]. Eq. (34)-(37) imply that the complete sets of right-moving modes in Regions I and III and the left-moving modes in Regions II and IV are entangled, in the same way that space-like separated Rindler modes in (R) and (L) and time-like separated conformal modes in (F) and (P) are entangled. In the following analysis, we harness this entanglement as the resource for teleportation between the accelerated and stationary observers.

#### IV. QUANTUM CIRCUIT MODEL

The quantum circuit model is a non-perturbative approach to describing interactions between observers in

relativistic, non-inertial reference frames and quantum fields [22, 23]. It describes these interactions as the Heisenberg evolution of Unruh operators ( $\hat{c}_{\omega i}, \hat{d}_{\omega i}$ ) into Rindler operators ( $\hat{b}_{\omega i}^X$ ), and back into Unruh operators, which can then be detected as Minkowski modes according to Eq. (16). The basis transformation between the Unruh and Rindler is defined in [22] and is essentially two-mode squeezing, the ‘source’ of entanglement.

The circuit in Fig. 3 imposes the all-optical teleportation protocol into the reference frames of accelerated Rob and conformal Charlie. We consider interactions with localised wavepacket modes in the accelerated (and conformal) frames, described by the operator

$$\hat{b}_g^X \equiv \int_0^\infty d\omega g(\omega) \hat{b}_\omega^X, \quad (39)$$

where  $g(\omega)$  assumes a Gaussian profile. The circuit diagram illustrates transformations of many single-frequency modes and the corresponding interaction in the accelerated frame as acting on a single, localised wavepacket mode, in the continuum limit. For the uni-

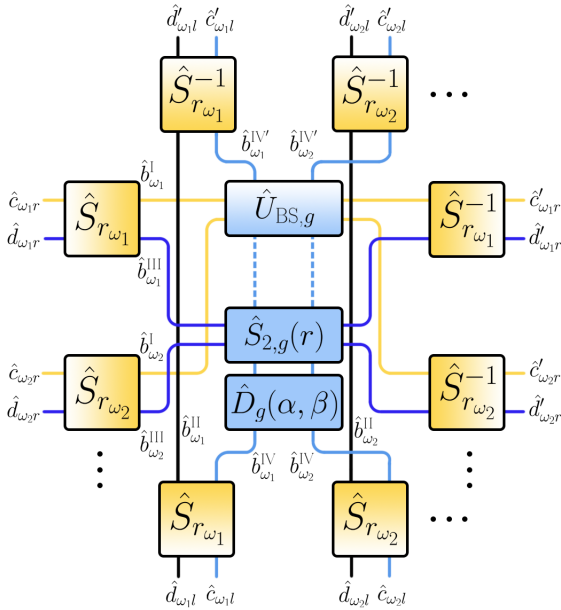

FIG. 3: Quantum circuit for teleportation between the accelerated sender and conformal receiver. The time-dependent interaction mixes different single-frequency Rindler modes, and the coloured lines identify Rindler modes confined to different regions of spacetime (these match Fig. 2). The accelerated observer creates the signal using  $\hat{D}_g(\alpha, \beta)$ , amplifies this through  $\hat{S}_{2,g}(r)$ , before the conformal receiver attenuates it using a beamsplitter,  $\hat{U}_{BS,g}$ . The classical channel is denoted by the dashed line.

tary interaction  $\hat{U}_g$  with an arbitrary Rindler wavepacket  $g(\omega)$ , there exist a complete set of wavepackets  $g_{\perp,i}(\omega)$  orthogonal to  $g(\omega)$  which do not interact with  $\hat{U}_g$ . Thus,

the single-frequency Rindler operators can be decomposed into an ‘interacting’ and ‘non-interacting’ part [29],

$$\hat{b}_\omega^X = g^*(\omega) \hat{b}_g^X + \sum_i g_{\perp,i}(\omega) \hat{b}_{g_{\perp,i}}^X. \quad (40)$$

Acting  $\hat{U}_g$  on a single-frequency Rindler operator yields

$$\hat{b}_\omega^{X'} = \hat{U}_g^\dagger \hat{b}_\omega^X \hat{U}_g = \hat{b}_\omega^X + g^*(\omega) (\hat{U}_g^\dagger \hat{b}_g^X \hat{U}_g - \hat{b}_g^X), \quad (41)$$

from Eq. (40). Using the relations between the single frequency Unruh and Rindler operators [22] and Eq. (40) and (41), we obtain the following expressions for the output left-moving Unruh operators [23]

$$\hat{c}'_{\omega l} = \hat{c}_{\omega l} + g^*(\omega) \cosh r_\omega (\hat{U}_g^\dagger \hat{b}_g^{IV} \hat{U}_g - \hat{b}_g^{IV}) \quad (42)$$

$$\hat{d}'_{\omega l} = \hat{d}_{\omega l} - g(\omega) \sinh r_\omega (\hat{U}_g^\dagger \hat{b}_g^{IV\dagger} \hat{U}_g - \hat{b}_g^{IV\dagger}). \quad (43)$$

where  $r_\omega = \text{arctanh } e^{-\pi\omega/a}$  is the two-mode squeezing factor. Alice reconstructs the Minkowski modes from  $\hat{c}'_{\omega l}, \hat{d}'_{\omega l}$ . In Fig. 3,  $\hat{D}_g(\alpha, \beta) = \hat{D}_g(\beta) \hat{D}_g(\alpha)$  where  $\hat{D}_g(\alpha)$  imposes a strong local oscillator to the classical signal  $\beta$ , prepared and teleported by Rob, which is an important feature of the self-homodyne detection model which we employ.

### A. Self-Homodyne Detection

Since the teleported state is unknown to the inertial observer, we model them as operating an infinite bandwidth detector that integrates over *all* Minkowski modes,

$$\hat{N} = \int_{-\infty}^{\infty} dk \hat{a}_k^\dagger \hat{a}_k, \quad (44)$$

This approximates a physical detector that captures a finite range of frequencies much larger than the spread of frequencies of the signal [23, 30]. By displacing the input Rindler mode by a strong local oscillator characterised by the complex amplitude  $\alpha = |\alpha| e^{i\phi}$ , the quadrature amplitudes of the input field now exhibit phase-dependent oscillations,

$$\hat{X}(\phi) = \hat{a} e^{-i\phi} + \hat{a}^\dagger e^{i\phi}, \quad (45)$$

where  $\phi$  is the phase of the displacement in phase space. In the limit where  $|\alpha| \gg 1$ ,  $\hat{N}(\phi)$  can be approximated as

$$\hat{N}(\phi) \simeq |\alpha|^2 + |\alpha|(\beta + \beta^*). \quad (46)$$

The quadrature operator can be written as

$$\langle \hat{X}(\phi) \rangle \simeq \frac{\langle \hat{N}(\phi) \rangle - \langle \hat{N}_0 \rangle}{\sqrt{\langle \hat{N}_0 \rangle}}, \quad (47)$$

where  $\langle \hat{N}_0 \rangle$  is the average number of photons when no signal  $\beta$ , is imposed. The variance of the quadrature amplitude is [23, 30]

$$(\Delta X(\phi))^2 = \frac{\langle \hat{N}^2(\phi) \rangle - \langle \hat{N}(\phi) \rangle^2}{\langle \hat{N}_0 \rangle} = \frac{(\Delta N(\phi))^2}{\langle \hat{N}_0 \rangle}, \quad (48)$$

where  $\Delta N(\phi)$  is the variance in the photon number according to the inertial detector. Conveniently, the purity of Gaussian states is quantified by Eq. (48), the criterion for which is that the product of the  $\phi = 0$  and  $\phi = \pi/2$  quadrature variances is equal to unity [31].

## V. ANALYTIC RESULTS

In the following analysis, we consider the teleportation of the following states from the accelerated frame:

- (a) a displaced Minkowski vacuum state (in the Rindler observer's frame, a displaced thermal state, acting as a classical signal) created by displacing  $\hat{b}_g^{\text{IV}}$  with  $\hat{D}_g(\beta)$  (Fig. 3) and,
- (b) a squeezed thermal state (a quantum signal) generated by single-mode squeezing the input Rindler mode  $\hat{b}_g^{\text{IV}}$ ,

and determine their purity according to Alice. For (a), an ideal teleportation protocol should result in Alice detecting a pure coherent state. We expect this from the result in [23], which found that *direct transmission* of the Rindler-displaced Minkowski vacuum was detected as a pure coherent state according to an inertial Minkowski observer.

### A. Displaced Thermal State

From Fig. 3,  $\hat{b}_g^{\text{IV}}$  evolves under the action of the unitary  $\hat{U}_g = \hat{U}_{\text{BS},g} \hat{S}_{2,g} \hat{D}_g(\alpha, \beta)$  as

$$\hat{b}_g^{\text{IV}'} = \hat{b}_g^{\text{IV}} + \hat{b}_g^{\text{III}\dagger} \tanh r - \hat{b}_g^{\text{I}} \sqrt{1 - (\cosh r)^{-2}} + \alpha + \beta, \quad (49)$$

where  $\alpha$  characterises the strong local oscillator, and  $\beta$  (with  $|\beta| \ll |\alpha|$ ) creates the displaced state which we analyse. Using Eq. (41) and assuming the limit of strong amplification of the field through the classical channel ( $r \gg 1$ ) the output single-frequency Rindler operator takes the form

$$\hat{b}_g^{\text{IV}'} \simeq \hat{b}_g^{\text{IV}} + g^*(\omega) (\hat{b}_g^{\text{III}\dagger} - \hat{b}_g^{\text{I}} + \alpha + \beta). \quad (50)$$

Since the left-moving modes originating in the past light cone do not interact with  $\hat{U}_g$ , then  $\hat{b}_g^{\text{IV}'} = \hat{b}_g^{\text{II}}$ . From Eq. (50) we find that Charlie, in the conformal reference frame, sees an approximation of the original state, which becomes better as the acceleration increases. This

becomes evident after decomposing the Rindler operators into their constituent Unruh operators and assuming  $g^*(\omega) = g(\omega)$ , such that:

$$\hat{b}_g^{\text{IV}'} \simeq \hat{b}_g^{\text{IV}} + g(\omega) [\varphi_{cs} (\hat{d}_{\omega r}^\dagger - \hat{c}_{\omega r}) + \alpha + \beta], \quad (51)$$

where

$$\varphi_{cs} = \int d\omega g(\omega) (\cosh r_\omega - \sinh r_\omega) \quad (52)$$

which vanishes in the limit of infinite acceleration. Eq. (51) is formally equivalent to Eq. (11) for the static case. In the limit of infinite acceleration, the right-moving Rindler modes become perfectly entangled, reducing the output Rindler operator to an identical reconstruction of the input displaced by the amplitude  $g(\omega)(\alpha + \beta)$ . Therefore, our model predicts the ideal teleportation of states sent between the uniformly accelerated sender in the right Rindler wedge and the conformal receiver restricted to the future, in the limit of infinite acceleration. We note however, that for large accelerations, the state becomes increasingly thermalised.

We now consider the purity of the output state according to an inertial observer with access to the entire Minkowski spacetime, which requires a transformation of the Rindler operators into Minkowski operators. Applying Eq. (42) and (43) to the output Rindler operators yields

$$\hat{c}'_{\omega l} = \hat{c}_{\omega l} + g^*(\omega) \cosh r_\omega (\hat{b}_g^{\text{III}\dagger} - \hat{b}_g^{\text{I}} + \alpha + \beta) \quad (53)$$

$$\hat{d}'_{\omega l} = \hat{d}_{\omega l} - g(\omega) \sinh r_\omega (\hat{b}_g^{\text{III}} - \hat{b}_g^{\text{I}\dagger} + \alpha^* + \beta^*). \quad (54)$$

Eq. (44) for the Minkowski photon number operator simplifies to

$$\hat{N} = \int d\omega (\hat{c}'_{\omega l} \hat{c}'_{\omega l} + \hat{d}'_{\omega l} \hat{d}'_{\omega l}), \quad (55)$$

where we have used the identities  $\int dk A_{k\omega} A_{k\omega}^* = \delta(\omega - \omega')$  and  $\int dk A_{k\omega} A_{k\omega'} = 0$ . Similarly, the square of the number operator is

$$\hat{N}^2 = \int d\omega \int d\gamma (c'_{\omega l} c'_{\omega l} + d'_{\omega l} d'_{\omega l}) (c'_{\gamma l} c'_{\gamma l} + d'_{\gamma l} d'_{\gamma l}). \quad (56)$$

By computing the relevant vacuum expectation values of the products of output Unruh operators, Eq. (48) for the photon number variance, and subsequently, the quadrature variance of the output state detected by Alice is found to be (details in Appendix A)

$$(\Delta X)^2 = \underbrace{2\mathcal{I}_{cs}(\mathcal{I}_c + \mathcal{I}_s)}_{\text{Thermal Noise}} + \underbrace{1}_{\text{QNL}} \quad (57)$$

where

$$\mathcal{I}_c = \int d\omega g(\omega)^2 \cosh^2 r_\omega \quad (58)$$

$$\mathcal{I}_s = \int d\omega g(\omega)^2 \sinh^2 r_\omega \quad (59)$$

$$\mathcal{I}_{cs} = \int d\omega g(\omega)^2 (\cosh r_\omega - \sinh r_\omega)^2. \quad (60)$$

In the limiting case where  $g(\omega)$  is a narrow bandwidth Rindler mode ( $\sigma \ll \omega_0$ ), the quadrature variance reduces to

$$(\Delta X)^2 \simeq (1 + \exp(-4r_0)) + 1. \quad (61)$$

For  $\omega_0/a \gg 1$ , the non-inertial (Charlie and Rob) observers are effectively reduced to a static, inertial frame. This occurs in the limits  $a \rightarrow 0$  with fixed  $\omega_0$  (smaller accelerations) or  $\omega_0 \gg 1$  with fixed  $a$ . In the latter case, the non-inertial observers interact with sufficiently high-frequency modes such that they are surrounded by vacuum (due to the exponentially decaying tail of the Planck spectrum). The input Rindler modes remain independent, so that two additional QNL are added to the output state, analogous to Eq. (8). As  $\omega_0/a \rightarrow 0$ ,

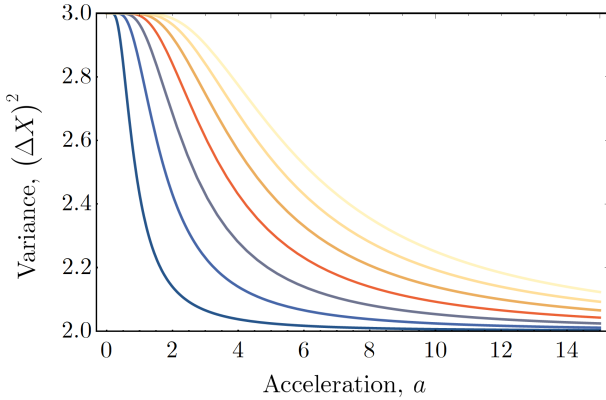

FIG. 4:  $(\Delta X)^2$  for the teleported state as detected by Alice in the Minkowski vacuum, as a function of the acceleration. The individual lines represent  $\omega_0 = 0.5, 1.0, \dots, 3.5$  (increasing from blue to yellow).

the right-moving resource modes become perfectly entangled. Curiously, the output state detected by the inertial Minkowski observer is not pure, but carries at best, an extra unit of QNL above the Heisenberg limit of unity. Even for a perfect entanglement resource, the state appears mixed according to the inertial observer, despite a reduction below the classical limit.

To understand this behaviour, we notice that Eq. (57) contains a thermal noise term in addition to the single QNL that originates from the Rindler mode displaced by Rob and teleported to Charlie. It was found in [23] that the direct transmission of a displaced Rindler mode

from the accelerated reference frame was detected as a pure coherent state according to an inertial Minkowski observer. Comparatively, the thermal noise term in Eq. (57) approaches one (an additional QNL) rather than vanishing in the limit of infinite acceleration, since the output Rindler mode *only reconstructs the input identically at infinite acceleration*. Hence, whilst the noise terms from the right-moving vacuum modes become *increasingly suppressed* with increasing acceleration (due to stronger entanglement between the resource modes  $\hat{b}_g^I$ ,  $\hat{b}_g^{III}$ ), they are *simultaneously amplified* due to the increasing thermalisation of the Unruh effect. These competing effects fortuitously balance one another, resulting in (for the ideal case of infinite acceleration) an additional QNL to the output state.

## B. Squeezed Thermal State

To examine the evolution of non-classical states through the teleportation protocol, we apply single-mode squeezing to the initial state prepared in the accelerated reference frame. We are also interested in how the teleported state is affected by the so-called decoherence effects found previously in [23, 30]. As before, we derive the output single-frequency Rindler operators, given by

$$\hat{b}_\omega^{IV'} = b_\omega^{IV} + g^*(\omega) (b_g^{IV} (\cosh r_s - 1) + b_g^{IV\dagger} \sinh r_s + b_g^{III\dagger} - b_g^{III} + \alpha), \quad (62)$$

where now  $\hat{U}_g = \hat{U}_{BS} \hat{S}_{2,g}(r) \hat{S}_{1,g}(r_s) \hat{D}_g(\alpha)$  and  $\hat{S}_{1,g}(r_s)$  squeezes the Rindler vacuum. It is straightforward to show that the output Unruh operators are

$$\hat{c}'_{\omega l} = \hat{c}_{\omega l} + g^*(\omega) \cosh r_\omega (b_g^{IV} (\cosh r_s - 1) + b_g^{IV\dagger} \sinh r_s + b_g^{III\dagger} - b_g^{III} + \alpha) \quad (63)$$

$$\hat{d}'_{\omega l} = \hat{d}_{\omega l} - g(\omega) \sinh r_\omega (b_g^{IV\dagger} (\cosh r_s - 1) + b_g^{IV} \sinh r_s + b_g^{III} - b_g^{III\dagger} + \alpha^*) \quad (64)$$

Performing a similar calculation to the previous case, we find that the quadrature variance of the state detected by the inertial Minkowski observer is given by,

$$(\Delta X(\phi))^2 = \underbrace{2\mathcal{I}_{cs}(\mathcal{I}_c + \mathcal{I}_s)}_{\text{Thermal Noise Term}} + \underbrace{\Delta(\phi)}_{\text{Decoherence Term}}, \quad (65)$$

where

$$\Delta(\phi) = \cosh 2r_s + 4\mathcal{I}_c(\mathcal{I}_c - 1)(\cosh 2r_s - 2 \cosh r_s + 1) + 2 \sinh r_s [(2\mathcal{I}_c - 1)^2 \cosh r_s - 4\mathcal{I}_c(\mathcal{I}_c - 1)] \cos(2\phi). \quad (66)$$

The maximum and minimum quadrature variances correspond to the phases  $\phi = 0, \pi/2$ :

$$(\Delta X(0))^2 = 2\mathcal{I}_{cs}(\mathcal{I}_c + \mathcal{I}_s) + \Delta(0) \quad (67)$$

$$(\Delta X(\pi/2))^2 = 2\mathcal{I}_{cs}(\mathcal{I}_c + \mathcal{I}_s) + \Delta(\pi/2) \quad (68)$$

where

$$\Delta(0) = e^{2r_s} + 4\mathcal{I}_c(\mathcal{I}_c - 1)(e^{r_s} - 1)^2 \quad (69)$$

$$\Delta(\pi/2) = e^{-2r_s} + 4\mathcal{I}_c(\mathcal{I}_c - 1)(e^{-r_s} - 1)^2. \quad (70)$$

Eq. (65) reveals two competing factors affecting the purity of the output state. The first is the thermal noise term found previously for the displaced Rindler vacuum state prepared and teleported by Rob, which is uncorrelated from the noise of the signal itself. The second is the decoherence term  $\Delta(\phi)$  which also appeared in [23] for a squeezed state sent from the accelerated frame to an inertial observer. There, it was concluded that such terms arise from the transformation of the bipartite Hilbert space of the Rindler and Unruh modes to the single Hilbert space of the Minkowski modes. This leads to a loss of phase information in the Unruh modes when computing the Minkowski particle number and the observed decoherence according to inertial detectors. For

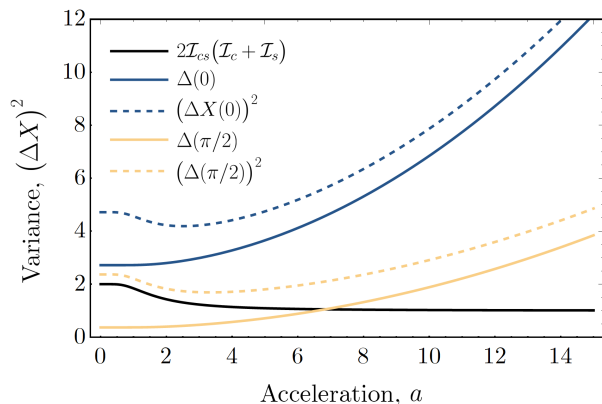

FIG. 5: Contributions to  $(\Delta X)^2$  for the squeezed thermal state as detected by the inertial observer in the Minkowski vacuum, with  $r_s = 0.5, \omega_0 = 1$ . The decoherence terms dominate for large  $a$ .

large  $\omega_0/a$ , the strengthening of entanglement between the Rindler modes reduces the noise on the output state, but as  $\omega_0/a$  decreases, the Unruh effect becomes significant and the variances grow unbounded. We conclude that the purity of the output state according to Alice, in the Minkowski vacuum, is affected by:

1. the thermal noise term, which encodes within it the competing suppression and amplification effects

discussed previously, and

2. the squeezing of the input Rindler mode, the source of the decoherence terms first found in [23].

## VI. CONCLUSION

The decoherence of quantum states prepared in an accelerated reference frame and detected by inertial observers has been studied previously [23, 30]. In [23], the authors argue that any interaction that leads to entanglement between the Unruh modes, as occurs for the squeezed Rindler vacuum state, appears as decoherence according to the measurements of inertial observers, whilst classical signals do not produce such entanglement. Nevertheless, we found that the displaced Rindler vacuum state prepared and teleported by Rob was still polluted by additional thermal noise terms according to the inertial Minkowski observer. We attributed this additional decoherence to the fact that the output state teleported to Charlie only becomes an identical reconstruction of the input at infinite acceleration, which is nullified by the opposing thermalisation effects of Unruh radiation in this limit.

As is evident from the simplicity of our calculations, the quantum circuit model presents a powerful tool for analysing quantum information protocols in relativistic, non-inertial settings, possessing some advantages over previous models. A prominent one is that the model is non-perturbative, which allows the evolution of quantum fields to be described by unitary operations. It is also a natural setting to analyse continuous-variable protocols where only discrete-variable versions have been studied, and these can be straightforwardly mapped to quantum optical contexts. An immediate extension to this work would be to implement other entanglement-based protocols using the quantum circuit model, such as continuous-variable dense coding [32, 33], quantum energy teleportation [34–38] and quantum key distribution [15].

## VII. ACKNOWLEDGEMENTS

This research is supported by the Australian Research Council (ARC) under the Centre of Excellence for Quantum Computation and Communication Technology (Grant No. CE170100012).



### Appendix A: Rindler-Displaced Minkowski Vacuum State

In the main text, we derived expressions for the output Unruh operators, given by

$$\hat{c}'_{\omega l} = \hat{c}_{\omega l} + g(\omega) \cosh r_{\omega} [\varphi_{cs}(\hat{c}'_{\omega' r} - \hat{d}'_{\omega' r}) + \alpha + \beta] \quad (\text{A1})$$

$$\hat{d}'_{\omega l} = \hat{d}_{\omega l} - g(\omega) \sinh r_{\omega} [\varphi_{cs}(\hat{c}'_{\omega' r} - \hat{d}'_{\omega' r}) + \alpha^* + \beta^*]. \quad (\text{A2})$$

We can conveniently express these as

$$\hat{c}'_{\omega l} = \alpha g(\omega) \cosh r_{\omega} + \hat{c}''_{\omega l} \quad (\text{A3})$$

$$\hat{d}'_{\omega l} = -\alpha^* g(\omega) \sinh r_{\omega} + \hat{d}''_{\omega l} \quad (\text{A4})$$

where  $c''_{\omega}$  and  $d''_{\omega}$  are terms not multiplied by  $|\alpha|$ . The Unruh particle numbers can thus be calculated using

$$c_{\omega l}^{\dagger} c'_{\omega l} = |\alpha|^2 g^2(\omega) \cosh^2 r_{\omega} + |\alpha| g(\omega) \cosh r_{\omega} [e^{i\phi} c_{\omega l}^{\dagger} + e^{-i\phi} c''_{\omega l}] \quad (\text{A5})$$

$$d_{\omega l}^{\dagger} d'_{\omega l} = |\alpha|^2 g^2(\omega) \sinh^2 r_{\omega} - |\alpha| g(\omega) \sinh r_{\omega} [e^{-i\phi} d_{\omega l}^{\dagger} + e^{i\phi} d''_{\omega l}] \quad (\text{A6})$$

where we have left out terms not multiplied by  $\alpha$  as small. The vacuum expectation value of the particle number is thus:

$$\langle 0 | \hat{N} | 0 \rangle = |\alpha|^2 (\mathcal{I}_c + \mathcal{I}_s). \quad (\text{A7})$$

The relevant expectation values in  $\langle 0_M | \hat{N}^2 | 0_M \rangle$  are:

$$\begin{aligned} \langle 0 | c_{\omega l}^{\dagger} c_{\gamma l}^{\dagger} | 0 \rangle &= \delta(\omega - \gamma) + g(\omega)g(\gamma) \cosh r_{\omega} \cosh r_{\gamma} \mathcal{I}_{cs} & \langle 0 | c_{\omega l}^{\dagger} d_{\gamma l}^{\dagger} | 0 \rangle &= -g(\omega)g(\gamma) \cosh r_{\omega} \sinh r_{\gamma} \mathcal{I}_{cs} \\ \langle 0 | c_{\omega l}^{\dagger} c''_{\gamma l} | 0 \rangle &= g(\omega)g(\gamma) \cosh r_{\omega} \cosh r_{\gamma} \mathcal{I}_{cs} & \langle 0 | c_{\omega l}^{\dagger} d''_{\gamma l} | 0 \rangle &= -g(\omega)g(\gamma) \cosh r_{\omega} \sinh r_{\gamma} \mathcal{I}_{cs} \\ \langle 0 | d_{\omega l}^{\dagger} d_{\gamma l}^{\dagger} | 0 \rangle &= \delta(\omega - \gamma) + g(\omega)g(\gamma) \sinh r_{\omega} \sinh r_{\gamma} \mathcal{I}_{cs} & \langle 0 | d_{\omega l}^{\dagger} c_{\gamma l} | 0 \rangle &= -g(\omega)g(\gamma) \sinh r_{\omega} \cosh r_{\gamma} \mathcal{I}_{cs} \\ \langle 0 | d_{\omega l}^{\dagger} d''_{\gamma l} | 0 \rangle &= g(\omega)g(\gamma) \sinh r_{\omega} \sinh r_{\gamma} \mathcal{I}_{cs} & \langle 0 | d_{\omega l}^{\dagger} c''_{\gamma l} | 0 \rangle &= -g(\omega)g(\gamma) \sinh r_{\omega} \cosh r_{\gamma} \mathcal{I}_{cs}. \end{aligned} \quad (\text{A8})$$

The terms in  $\langle 0 | \hat{N}^2 | 0 \rangle$  are:

$$\langle 0 | \hat{c}'_{\omega l} \hat{c}'_{\omega l} \hat{c}'_{\gamma l} \hat{c}'_{\gamma l} | 0 \rangle = |\alpha|^2 g^2(\omega) g^2(\gamma) \cosh r_{\omega l} \cosh r_{\gamma l} [\delta(\omega - \gamma) + 2\mathcal{I}_{cs} \cosh r_{\omega l} \cosh r_{\gamma l}] \quad (\text{A9})$$

$$\langle 0 | \hat{d}'_{\omega l} \hat{d}'_{\omega l} \hat{d}'_{\gamma l} \hat{d}'_{\gamma l} | 0 \rangle = |\alpha|^2 g^2(\omega) g^2(\gamma) \sinh r_{\omega l} \sinh r_{\gamma l} [\delta(\omega - \gamma) + 2\mathcal{I}_{cs} \sinh r_{\omega l} \sinh r_{\gamma l}]$$

$$\langle 0 | \hat{c}'_{\omega l} \hat{c}'_{\omega l} \hat{d}'_{\gamma l} \hat{d}'_{\gamma l} | 0 \rangle = 2|\alpha|^2 g^2(\omega) g^2(\gamma) \cosh^2 r_{\omega l} \sinh^2 r_{\gamma l} \mathcal{I}_{cs} \quad (\text{A10})$$

$$\langle 0 | \hat{d}'_{\omega l} \hat{d}'_{\omega l} \hat{c}'_{\gamma l} \hat{c}'_{\gamma l} | 0 \rangle = 2|\alpha|^2 g^2(\omega) g^2(\gamma) \sinh^2 r_{\omega l} \cosh^2 r_{\gamma l} \mathcal{I}_{cs} \quad (\text{A11})$$

where we have left out the terms fourth order in  $|\alpha|$ , since they are subtracted away by the  $\langle 0 | \hat{N} | 0 \rangle^2$  term in the variance. Adding these terms together, integrating with respect to  $\omega, \gamma$  and then normalising this by the strength of the local oscillator  $|\alpha|^2 (\mathcal{I}_c + \mathcal{I}_s)$  yields Eq. (57).

### Appendix B: Rindler Squeezed Minkowski Vacuum State

Likewise with the displaced thermal state, we derive expressions for the output Unruh operators, given by

$$\begin{aligned} \hat{c}'_{\omega l} &= \hat{c}_{\omega l} + g(\omega) \cosh r_{\omega l} \left[ (\cosh r_s - 1) \int d\omega' g(\omega') (\cosh r_{\omega'} \hat{c}_{\omega'}^{\alpha} + \sinh r_{\omega'} \hat{d}_{\omega'}^{\alpha \dagger}) \right. \\ &\quad \left. + \sinh r_s \int d\omega' g^*(\omega') (\cosh r_{\omega'} \hat{c}_{\omega'}^{\alpha \dagger} + \sinh r_{\omega'} \hat{d}_{\omega'}^{\alpha}) + \varphi_{cs}(\hat{c}_{\omega'}^{\beta \dagger} - \hat{d}_{\omega'}^{\beta}) + \alpha \right] \end{aligned} \quad (\text{B1})$$

$$\begin{aligned} \hat{d}'_{\omega l} &= \hat{d}_{\omega l} - g(\omega) \sinh r_{\omega l} \left[ (\cosh r_s - 1) \int d\omega' g^*(\omega') (\cosh r_{\omega'} \hat{c}_{\omega'}^{\alpha \dagger} + \sinh r_{\omega'} \hat{d}_{\omega'}^{\alpha}) \right. \\ &\quad \left. + \sinh r_s \int d\omega' g(\omega') (\cosh r_{\omega'} \hat{c}_{\omega'}^{\alpha} + \sinh r_{\omega'} \hat{d}_{\omega'}^{\alpha \dagger}) + \varphi_{cs}(\hat{c}_{\omega'} - \hat{d}_{\omega'}^{\beta \dagger}) + \alpha^* \right]. \end{aligned} \quad (\text{B2})$$

$\langle 0|\hat{N}|0\rangle$  is the same as previously derived. As before, the relevant expectation value for the products of Unruh operators are:

$$\begin{aligned}
\langle 0|c''_{\omega l}c''_{\gamma l}|0\rangle &= g(\omega)g(\gamma)\cosh r_{\omega}\cosh r_{\gamma}\psi_{cc} & \langle 0|d''_{\omega l}d''_{\gamma l}|0\rangle &= g(\omega)g(\gamma)\sinh r_{\omega}\sinh r_{\gamma}\psi_{dd} \\
\langle 0|c^{\dagger''}_{\omega l}c^{\dagger''}_{\gamma l}|0\rangle &= g(\omega)g(\gamma)\cosh r_{\omega}\cosh r_{\gamma}\psi_{cc} & \langle 0|d^{\dagger''}_{\omega l}d^{\dagger''}_{\gamma l}|0\rangle &= g(\omega)g(\gamma)\sinh r_{\omega}\sinh r_{\gamma}\psi_{dd} \\
\langle 0|c''_{\omega l}c^{\dagger''}_{\gamma l}|0\rangle &= \delta(\omega-\gamma)+g(\omega)g(\gamma)\cosh r_{\omega}\cosh r_{\gamma}\bar{\phi}_{cc} & \langle 0|d''_{\omega l}d^{\dagger''}_{\gamma l}|0\rangle &= \delta(\omega-\gamma)+g(\omega)g(\gamma)\sinh r_{\omega}\sinh r_{\gamma}\bar{\phi}_{dd} \\
\langle 0|c^{\dagger''}_{\omega l}c^{\dagger''}_{\gamma l}|0\rangle &= g(\omega)g(\gamma)\cosh r_{\omega}\cosh r_{\gamma}\phi_{cc} & \langle 0|d^{\dagger''}_{\omega l}d^{\dagger''}_{\gamma l}|0\rangle &= g(\omega)g(\gamma)\sinh r_{\omega}\sinh r_{\gamma}\phi_{dd}
\end{aligned} \tag{B3}$$

where

$$\begin{aligned}
\psi_{cc} &= \sinh r[(\cosh r - 1)(\mathcal{I}_c + \mathcal{I}_s) + 1] & \psi_{dd} &= \sinh r[(\cosh r - 1)(\mathcal{I}_c + \mathcal{I}_s) - 1] \\
\phi_{cc} &= (\cosh r - 1)^2\mathcal{I}_s + \sinh^2 r\mathcal{I}_c + \mathcal{I}_{cs} & \phi_{dd} &= (\cosh r - 1)^2\mathcal{I}_c + \sinh^2 r\mathcal{I}_s + \mathcal{I}_{cs} \\
\bar{\phi}_{cc} &= 2(\cosh r - 1) + (\cosh r - 1)^2\mathcal{I}_c + \sinh^2 r\mathcal{I}_s + \mathcal{I}_{cs} & \bar{\phi}_{dd} &= -2(\cosh r - 1) + (\cosh r - 1)^2\mathcal{I}_c + \sinh^2 r\mathcal{I}_s + \mathcal{I}_{cs}.
\end{aligned} \tag{B4}$$

For the cross-terms, we have:

$$\begin{aligned}
\langle 0|c''_{\omega l}d''_{\gamma l}|0\rangle &= -g(\omega)g(\gamma)\cosh r_{\omega}\sinh r_{\gamma}[\bar{\phi}_{cc} - (\cosh r - 1)] & \langle 0|c''_{\omega l}d^{\dagger''}_{\gamma l}|0\rangle &= -g(\omega)g(\gamma)\cosh r_{\omega}\sinh r_{\gamma}\gamma_{cd} \\
\langle 0|c^{\dagger''}_{\omega l}d^{\dagger''}_{\gamma l}|0\rangle &= -g(\omega)g(\gamma)\cosh r_{\omega}\sinh r_{\gamma}[\bar{\phi}_{dd} + (\cosh r - 1)] & \langle 0|c^{\dagger''}_{\omega l}d''_{\gamma l}|0\rangle &= -g(\omega)g(\gamma)\cosh r_{\omega}\sinh r_{\gamma}\gamma_{cd} \\
\langle 0|d''_{\omega l}c''_{\gamma l}|0\rangle &= -g(\omega)g(\gamma)\sinh r_{\omega}\cosh r_{\gamma}[\bar{\phi}_{dd} + (\cosh r - 1)] & \langle 0|d''_{\omega l}c^{\dagger''}_{\gamma l}|0\rangle &= -g(\omega)g(\gamma)\sinh r_{\omega}\cosh r_{\gamma}\gamma_{cd} \\
\langle 0|d^{\dagger''}_{\omega l}c^{\dagger''}_{\gamma l}|0\rangle &= -g(\omega)g(\gamma)\sinh r_{\omega}\cosh r_{\gamma}[\bar{\phi}_{cc} - (\cosh r - 1)] & \langle 0|d^{\dagger''}_{\omega l}c''_{\gamma l}|0\rangle &= -g(\omega)g(\gamma)\sinh r_{\omega}\cosh r_{\gamma}\gamma_{cd}
\end{aligned} \tag{B5}$$

where  $\gamma_{cd} = (\cosh r - 1)\sinh r(\mathcal{I}_c + \mathcal{I}_s)$ . Thus, the relevant terms in  $\langle 0|\hat{N}^2|0\rangle$  are:

$$\begin{aligned}
\langle 0|\hat{c}^{\dagger}_{\omega l}\hat{c}'_{\omega l}\hat{c}^{\dagger}_{\gamma l}\hat{c}'_{\gamma l}|0\rangle &= |\alpha|^2g^2(\omega)g^2(\gamma)\cosh r_{\omega}\cosh r_{\gamma}[\delta(\omega-\gamma) + 2\bar{\phi}_{cc}\cosh r_{\omega}\cosh r_{\gamma} + 2\cos(2\phi)\cosh r_{\omega}\cosh r_{\gamma}\psi_{cc}] \\
\langle 0|\hat{d}^{\dagger}_{\omega l}\hat{d}'_{\omega l}\hat{d}^{\dagger}_{\gamma l}\hat{d}'_{\gamma l}|0\rangle &= |\alpha|^2g^2(\omega)g^2(\gamma)\sinh r_{\omega}\sinh r_{\gamma}[\delta(\omega-\gamma) + 2\bar{\phi}_{dd}\sinh r_{\omega l}\sinh r_{\gamma} + 2\cos(2\phi)\sinh r_{\omega}\sinh r_{\gamma}\psi_{dd}] \\
\langle 0|\hat{c}^{\dagger}_{\omega l}\hat{c}'_{\omega l}\hat{d}^{\dagger}_{\gamma l}\hat{d}'_{\gamma l}|0\rangle &= |\alpha|^2g^2(\omega)g^2(\gamma)\cosh^2 r_{\omega}\sinh^2 r_{\gamma}[\bar{\phi}_{cc} + \bar{\phi}_{dd} + 2\cos(2\phi)\gamma_{cd}] \\
\langle 0|\hat{d}^{\dagger}_{\omega l}\hat{d}'_{\omega l}\hat{c}^{\dagger}_{\gamma l}\hat{c}'_{\gamma l}|0\rangle &= |\alpha|^2g^2(\omega)g^2(\gamma)\sinh^2 r_{\omega}\cosh^2 r_{\gamma}[\bar{\phi}_{cc} + \bar{\phi}_{dd} + 2\cos(2\phi)\gamma_{cd}].
\end{aligned} \tag{B6}$$

As before, we add these terms together and integrate over  $\omega, \gamma$  to obtain the photon number variance. After normalising by the strength of the local oscillator, we obtain Eq. (65)

- 
- |                                                                                                                                                                                                                                                                                                                                                                                                                                                                                                                                                                                                                                                                                                                                                                                                                                                                                                            |                                                                                                                                                                                                                                                                                                                                                                                                                                                                                                                                                                                                                                                                                                                                                                                                                                                                        |
|------------------------------------------------------------------------------------------------------------------------------------------------------------------------------------------------------------------------------------------------------------------------------------------------------------------------------------------------------------------------------------------------------------------------------------------------------------------------------------------------------------------------------------------------------------------------------------------------------------------------------------------------------------------------------------------------------------------------------------------------------------------------------------------------------------------------------------------------------------------------------------------------------------|------------------------------------------------------------------------------------------------------------------------------------------------------------------------------------------------------------------------------------------------------------------------------------------------------------------------------------------------------------------------------------------------------------------------------------------------------------------------------------------------------------------------------------------------------------------------------------------------------------------------------------------------------------------------------------------------------------------------------------------------------------------------------------------------------------------------------------------------------------------------|
| <p>[1] N. D. Birrell and P. Davies, <i>Quantum fields in curved space</i>, 7 (Cambridge university press, 1984).</p> <p>[2] W. G. Unruh, <i>Physical Review D</i> <b>14</b>, 870 (1976).</p> <p>[3] L. C. B. Crispino, A. Higuchi, and G. E. A. Matsas, <i>Reviews of Modern Physics</i> <b>80</b>, 787 (2008).</p> <p>[4] P. M. Alsing and P. W. Milonni, <i>American Journal of Physics</i> <b>72</b>, 1524 (2004).</p> <p>[5] P. C. Davies, <i>Journal of Physics A: Mathematical and General</i> <b>8</b>, 609 (1975).</p> <p>[6] B. Reznik, <i>Foundations of Physics</i> <b>33</b>, 167 (2003).</p> <p>[7] B. Reznik, A. Retzker, and J. Silman, <i>Physical Review A</i> <b>71</b>, 042104 (2005).</p> <p>[8] S. J. Olson and T. C. Ralph, <i>Physical Review Letters</i> <b>106</b>, 110404 (2011).</p> <p>[9] S. J. Olson and T. C. Ralph, <i>Physical Review A</i> <b>85</b>, 012306 (2012).</p> | <p>[10] G. Salton, R. B. Mann, and N. C. Menicucci, <i>New Journal of Physics</i> <b>17</b>, 035001 (2015).</p> <p>[11] Y. Nambu, <i>Entropy</i> <b>15</b>, 1847 (2013).</p> <p>[12] S. Kukita and Y. Nambu, <i>Classical and Quantum Gravity</i> <b>34</b>, 235010 (2017).</p> <p>[13] E. Martin-Martinez and N. C. Menicucci, <i>Classical and Quantum Gravity</i> <b>31</b>, 214001 (2014).</p> <p>[14] G. Ver Steeg and N. C. Menicucci, <i>Physical Review D</i> <b>79</b>, 044027 (2009).</p> <p>[15] T. Ralph and N. Walk, <i>New Journal of Physics</i> <b>17</b>, 063008 (2015).</p> <p>[16] B. Reznik, arXiv preprint quant-ph/0008006 (2000).</p> <p>[17] J.-i. Koga, G. Kimura, and K. Maeda, <i>Physical Review A</i> <b>97</b>, 062338 (2018).</p> <p>[18] A. G. S. Landulfo and G. E. A. Matsas, <i>Physical Review A</i> <b>80</b>, 032315 (2009).</p> |
|------------------------------------------------------------------------------------------------------------------------------------------------------------------------------------------------------------------------------------------------------------------------------------------------------------------------------------------------------------------------------------------------------------------------------------------------------------------------------------------------------------------------------------------------------------------------------------------------------------------------------------------------------------------------------------------------------------------------------------------------------------------------------------------------------------------------------------------------------------------------------------------------------------|------------------------------------------------------------------------------------------------------------------------------------------------------------------------------------------------------------------------------------------------------------------------------------------------------------------------------------------------------------------------------------------------------------------------------------------------------------------------------------------------------------------------------------------------------------------------------------------------------------------------------------------------------------------------------------------------------------------------------------------------------------------------------------------------------------------------------------------------------------------------|

- [19] S.-Y. Lin, C.-H. Chou, and B. L. Hu, *Physical Review D* **91**, 084063 (2015).
- [20] P. M. Alsing and G. J. Milburn, *Physical review letters* **91**, 180404 (2003).
- [21] P. M. Alsing, D. McMahon, and G. Milburn, *Journal of Optics B: Quantum and Semiclassical Optics* **6**, S834 (2004).
- [22] D. Su, C. M. Ho, R. B. Mann, and T. C. Ralph, *New Journal of Physics* **19**, 063017 (2017).
- [23] D. Su and T. C. Ralph, *Physical Review X* **9**, 011007 (2019).
- [24] C. H. Bennett, G. Brassard, C. Crépeau, R. Jozsa, A. Peres, and W. K. Wootters, *Physical review letters* **70**, 1895 (1993).
- [25] L. Vaidman, *Physical Review A* **49**, 1473 (1994).
- [26] S. L. Braunstein and H. J. Kimble, *Physical Review Letters* **80**, 869 (1998).
- [27] T. C. Ralph, *Optics letters* **24**, 348 (1999).
- [28] A. Higuchi, S. Iso, K. Ueda, and K. Yamamoto, *Physical Review D* **96**, 083531 (2017).
- [29] P. P. Rohde, W. Mauerer, and C. Silberhorn, *New Journal of Physics* **9**, 91 (2007).
- [30] S. Onoe, D. Su, and T. C. Ralph, *Physical Review D* **98**, 036011 (2018).
- [31] H.-A. Bachor and T. C. Ralph, *A guide to experiments in quantum optics* (Wiley, 2004).
- [32] S. L. Braunstein and H. J. Kimble, in *Quantum Information with Continuous Variables* (Springer, 2000), pp. 95–103.
- [33] T. C. Ralph and E. H. Huntington, *Physical Review A* **66**, 042321 (2002).
- [34] M. Hotta, *Journal of the Physical Society of Japan* **78**, 034001 (2009).
- [35] M. Hotta, *Physical Review D* **81**, 044025 (2010).
- [36] M. Hotta, J. Matsumoto, and G. Yusa, *Physical Review A* **89**, 012311 (2014).
- [37] N. Funai and E. Martín-Martínez, *Physical Review D* **96**, 025014 (2017).
- [38] G. Verdon-Akzam, E. Martín-Martínez, and A. Kempf, *Physical Review A* **93**, 022308 (2016).