

PLANAR LEGENDRIAN Θ -GRAPHS

PETER LAMBERT-COLE AND DANIELLE O'DONNOL[†]

ABSTRACT. We classify topologically trivial Legendrian Θ -graphs and identify the complete family of nondestabilizeable Legendrian realizations in this topological class. In contrast to all known results for Legendrian knots, this is an infinite family of graphs. We also show that any planar graph that contains a subdivision of a Θ -graph or $S^1 \vee S^1$ as a subgraph will have an infinite number of distinct, topologically trivial nondestabilizeable Legendrian embeddings. Additionally, we introduce two moves, vertex stabilization and vertex twist, that change the Legendrian type within a smooth isotopy class.

1. INTRODUCTION

A *Legendrian graph* in a contact manifold (M, ξ) is an embedding $g : G \rightarrow (M, \xi)$ of an abstract graph G such that the image of each edge is tangent to the contact structure. In contrast with the study of Legendrian knots and links, relatively little is known about Legendrian graphs. Only a few spatial graph types have been classified and there are several realization and non-realization results for Legendrian graphs in (S^3, ξ_{std}) or equivalently $(\mathbb{R}^3, \xi_{std})$.

Eliashberg and Fraser proved that all Legendrian embeddings of an abstract tree are Legendrian isotopic [EF09]. The second author and Pavelescu classified topologically trivial Legendrian embeddings of the Lollipop and Handcuff graphs [OP12]. A graph G has a Legendrian embedding with all cycles maximal unknots if and only if it does not contain K_4 as a minor [OP12]. However, K_4 does have a Legendrian embedding where each cycle has maximal Thurston-Bennequin number in its smooth isotopy class [Tan15]. It is unknown whether every G has such a Legendrian embedding. The second author and Pavelescu solved the geography problem for Legendrian embeddings of the Θ -graph where each cycle is unknotted [OP14]. They gave necessary and sufficient conditions for fixed vectors to be realized as Thurston-Bennequin and rotation invariants of such Legendrian Θ -graphs. In [OP16] they found further restrictions on the Thurston-Bennequin and rotation invariants of unknotted embeddings of complete and complete bipartite graphs.

In this paper, we completely classify topologically trivial Legendrian embeddings of the Θ -graph in (S^3, ξ_{std}) . Our key technical tool is the main result in [LCO16] that the Legendrian ribbon R_g and rotation invariant rot_g are a complete pair of invariants for topologically trivial Legendrian graphs.

Before stating the classification, we first describe some interesting consequences that distinguish Legendrian graphs from Legendrian knots. For a fixed isotopy class of embeddings, the set of Legendrian realizations up to Legendrian isotopy is “generated” by a set of nondestabilizeable Legendrian realizations. Specifically, there exists a set \mathcal{N} of Legendrian embeddings such that

- (1) every Legendrian embedding in the isotopy class is obtained by a finite sequence of stabilizations from some element of \mathcal{N} , and

2010 *Mathematics Subject Classification.* 53D10; 57M15; 05C10.

Key words and phrases. Contact Topology, Legendrian graphs.

[†] This work was partially supported by the National Science Foundation grant DMS-160036.

(2) no embedding in \mathcal{N} admits a destabilization.

See Section 2 for a precise description of stabilization. For all smooth knot types for which the set \mathcal{N} is known, it is finite. However, this is not true for topologically trivial Legendrian Θ -graphs. There exists an infinite family $\{G_l\}$ of nondestabilizable realizations. The front projection of G_l is given as follows. Fix two points in the xz -plane and connect them by 3 arcs with no cusps. Now, take $l \in \frac{1}{2}\mathbb{Z}_{\geq -\frac{1}{2}}$, collect the bottom 2 strands and add $l + \frac{1}{2}$ twists as in Figure ?? . Call this graph G_l .

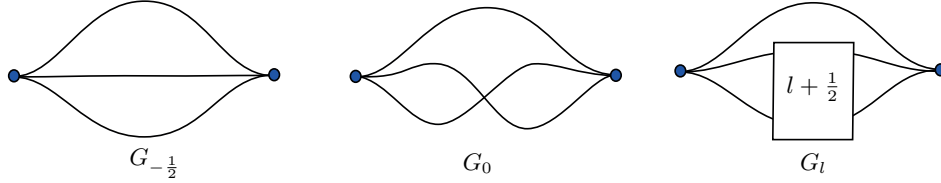

FIGURE 1. On the left is a front projection of $G_{-\frac{1}{2}}$ of the Θ -graph. In the center a G_0 realization of the Θ -graph. On the right is a front projection of G_l of the Θ -graph.

Theorem 1.1. *The infinite family $\{G_l\}$, where $l \in \frac{1}{2}\mathbb{Z}$ and $l \geq -\frac{1}{2}$, are nondestabilizable and pairwise non-Legendrian isotopic.*

This result is a sharp contrast with what is known about Legendrian knots. Moreover, it is always true if G is abstractly planar and contains a subdivision of the Θ -graph as a subgraph.

Theorem 1.2. *Let G be an abstract planar graph that contains a subdivision of the Θ -graph or $S^1 \vee S^1$ as a subgraph. Then there exists infinitely many, pairwise-distinct, topologically trivial Legendrian embeddings $g : G \rightarrow (S^3, \xi_{std})$.*

Fuchs and Tabachnikov [FT97] proved that if L_1, L_2 are Legendrian knots that are smoothly isotopic, then there exists a sequence of (de)stabilizations that connect L_1 and L_2 . However, the stabilization move (which we refer to here as an *edge stabilization*) is not sufficient to connect any two Legendrian realizations of the same spatial graph.

Theorem 1.3. *Two embeddings G_l and $G_{l'}$ are related by a sequence of edge stabilizations if and only if $l - l' \in \mathbb{Z}$.*

We introduce two new operations, called *vertex stabilization* and *vertex twist*, that modify Legendrian graphs without affecting the smooth isotopy class. We conjecture that, together with edge stabilizations, these form a complete set of operations relating any two Legendrian graphs in the same smooth isotopy class.

Conjecture 1.4. *Let G be a graph and $g : G \rightarrow S^3$ a smooth embedding. Then any two Legendrian realization g_1 and g_2 in (S^3, ξ_{std}) of g are related, up to Legendrian isotopy, by a sequence of edge stabilizations, vertex stabilizations, and vertex twists.*

Using the techniques of [LCO16], we have a proof of this conjecture if g is topologically trivial but not for arbitrary isotopy classes.

Now we address the classification. The Θ -graph consists of two vertices v_1, v_2 and three edges e_1, e_2, e_3 . There are three cycles $\gamma_1 = e_1 \cup e_2; \gamma_2 = e_2 \cup e_3; \gamma_3 = e_3 \cup e_1$. We orient the cycle γ_i so that e_i is oriented from v_1 to v_2 . Throughout this paper, we let Θ denote the abstract graph and θ denote

a topologically trivial embedding $\theta : \Theta \rightarrow (S^3, \xi_{std})$. The Thurston-Bennequin and rotation numbers of each cycle determine vectors $\overline{tb}_\theta, \overline{rot}_\theta \in \mathbb{Z}^3$

$$\begin{aligned}\overline{tb}_\theta &:= (tb_\theta(\gamma_1), tb_\theta(\gamma_2), tb_\theta(\gamma_3)) \\ \overline{rot}_\theta &:= (rot_\theta(\gamma_1), rot_\theta(\gamma_2), rot_\theta(\gamma_3))\end{aligned}$$

We also think of the pair $(\overline{tb}_\theta, \overline{rot}_\theta)$ as a vector in \mathbb{Z}^6 . Let $Rot_\theta := rot_\theta(\gamma_1) + rot_\theta(\gamma_2) + rot_\theta(\gamma_3)$ denote the *total rotation number* of θ .

Recall that for the study of knotted graphs, there is an important distinction between embeddings $g : G \rightarrow M$ and their images. Given an abstract graph G , a spatial embedding $j : G \rightarrow S^3$, and an automorphism ϕ of G , it is not true in general that there exists an ambient isotopy h satisfying $h \circ j = j \circ \phi$. Hence it is necessary to distinguish between embeddings of G up to ambient isotopy and their images up to ambient isotopy. Pictorially, this corresponds to a difference between unlabeled diagrams up to equivalence and labeled diagrams up to equivalence. In particular, consider the graph $G_{-\frac{1}{2}}$ in Figure 1. All possible ways to label the edges and vertices have the same image; however, there exists different labeling choices such that there is no sequence of Reidemeister moves that equates the two as labeled graphs. This is analogous to a non-invertible knot.

The automorphisms of Θ are permutations of the vertices and edges and so the automorphism group $\text{Aut}(\Theta)$ is $S_2 \times S_3$. Under $\phi \in \text{Aut}(\Theta)$, the image or orientation of a cycle may change and so the invariants $\overline{tb}_\theta, \overline{rot}_\theta$ change as well after relabeling by ϕ . In Section 3, we define representations ρ_2, ρ_3 of the symmetric groups S_2, S_3 on \mathbb{Z}^6 that describe the algebraic effect on the classical invariants $(\overline{tb}, \overline{rot})$ of permuting the vertices and edges, respectively. Certain symmetries of $(\overline{tb}, \overline{rot})$ under the action by $\rho = \rho_2 \times \rho_3$ correspond to relabelings of a graph.

Theorem 1.5. *The classification of topologically trivial Legendrian embeddings of the Θ -graph in (S^3, ξ_{std}) is as follows:*

- (1) *The set $\{G_l\}$ for $l \in \frac{1}{2}\mathbb{Z}$ and $l \geq -\frac{1}{2}$ is the set of nondestabilizeable, topologically trivial Legendrian embeddings $\theta : \Theta \rightarrow (S^3, \xi_{std})$.*
- (2) *If $\overline{tb}, \overline{rot} \in \mathbb{Z}^3$ satisfy*

$$\begin{aligned}tb(\gamma_i) + |rot(\gamma_i)| &\leq -1 \\ tb(\gamma_i) + rot(\gamma_i) &= 1 \pmod{2} \\ Rot &\in \{-1, 0, 1\}\end{aligned}$$

for $i = 1, 2, 3$, then there exists a topologically trivial Legendrian embedding θ with $(\overline{tb}_\theta, \overline{rot}_\theta) = (\overline{tb}, \overline{rot})$.

- (3) *Let $(\overline{tb}, \overline{rot})$ be an admissible pair. Then*
 - (a) *if $Rot = 0$, there exist two distinct, topologically trivial embeddings θ_1, θ_2 with $(\overline{tb}_{\theta_i}, \overline{rot}_{\theta_i}) = (\overline{tb}, \overline{rot})$, and*
 - (b) *if $Rot = \pm 1$, there exists one topologically trivial embedding θ with $(\overline{tb}_\theta, \overline{rot}_\theta) = (\overline{tb}, \overline{rot})$.*
- (4) *Let $(\overline{tb}, \overline{rot})$ be an admissible pair with $Rot = 0$. Then*
 - (a) *if $\rho_3(\tau) \cdot (\overline{tb}, \overline{rot}) = (\overline{tb}, \overline{rot})$ for some transposition $\tau \in S_3$, then up to relabeling there exists one topologically trivial embedding θ with $(\overline{tb}_\theta, \overline{rot}_\theta) = (\overline{tb}, \overline{rot})$.*
 - (b) *if $\rho_3(\tau) \cdot (\overline{tb}, \overline{rot}) \neq (\overline{tb}, \overline{rot})$ for every transposition $\tau \in S_3$, then up to relabeling there exists two topologically trivial embeddings θ_1, θ_2 with $(\overline{tb}_{\theta_i}, \overline{rot}_{\theta_i}) = (\overline{tb}, \overline{rot})$.*

2. BACKGROUND

2.1. Spatial graphs. An *abstract graph* or *graph* G is a 1-complex consisting of vertices and the edges connecting them. A *spatial graph* or *spatial embedding* is an embedding of a fixed abstract graph into a 3-manifold M . Two spatial graphs $f(G)$ and $\bar{f}(G)$ are *ambient isotopic* if there exists an isotopy $h_t : \mathbb{R}^3 \rightarrow \mathbb{R}^3$ such that $h_0 = id$ and $h_1(f(G)) = \bar{f}(G)$. As with knots, there is a set of Reidemeister moves for spatial graphs described by Kauffman in [Kau89].

There is an additional subtlety when working with spatial graphs. It is necessary to distinguish between embeddings of a graph up to ambient isotopy and its images up to ambient isotopy. Given an abstract graph G , a spatial embedding $j : G \rightarrow S^3$, and an automorphism ϕ of G , it is not true in general that there exists an ambient isotopy h satisfying $h \circ j = j \circ \phi$. In this article we are working with embeddings of graphs up to ambient isotopy. This corresponds to working with labeled diagrams up to equivalence. Without the labels the diagrams can look the same for different graphs because different edges are in the same positions. A spatial graph is *topologically trivial* if it lies on an embedded S^2 in S^3 .

2.2. Legendrian graphs. A (cooriented) *contact structure* (M, ξ) on a 3-manifold M is a plane field $\xi = \ker(\alpha)$ where the 1-form α satisfies the nonintegrability condition $\alpha \wedge d\alpha > 0$. As a result, the contact structure induces an orientation on M and the 2-form $d\alpha$ orients the contact planes. The basic example is the standard contact structure $\xi = \ker(dz - ydx)$ on \mathbb{R}^3 . This can be extended by the one-point compactification of \mathbb{R}^3 to the standard structure on S^3 .

A spatial graph is *Legendrian* if its image is tangent to the contact planes at every point. Two Legendrian graphs G_0 and G_1 are *Legendrian isotopic* if there exists a one-parameter family of Legendrian graphs G_t , where $t \in [0, 1]$. For a Legendrian graph in $(\mathbb{R}^3, \xi_{std})$, the projection to the xz -plane is called the *front projection*. Though we are working in (S^3, ξ_{std}) we will work with a projection in \mathbb{R}^3 ; this is possible since Legendrian graphs and isotopes of Legendrian graphs can be perturbed slightly to miss a chosen point. The front projection is usually given as an immersion, since at any crossing the strand that is over is determined by the slope of the tangents. However, at times we will show diagrams where the crossings are indicated for added clarity. A front projection of the Legendrian graph that is in general position with all double points away from vertices is called *generic*. Two generic front projections of a Legendrian graph are related by the three Reidemeister moves for knots and links together with two moves given by the mutual position of vertices and edges [BI09]. See Figure 2.

There are a number of different invariants for Legendrian graphs. The first two are a generalization of the classical invariants, Thurston–Bennequin, tb , and rotation number, rot , to graphs [OP12]. For a Legendrian graph g , with an ordering on its cycles, the *Thurston–Bennequin number*, \overline{tb}_g , is the ordered list of the Thurston–Bennequin numbers for its cycles. Similarly, the *rotation number*, \overline{rot}_g , is the ordered list of the rotation numbers for its cycles.

In a front diagram, the Thurston–Bennequin number and rotation number of an oriented cycle γ can be computed by the formulas

$$tb_g(\gamma) = -\frac{1}{2} \# \text{cusps} + \text{writhe} \qquad rot_g(\gamma) = \frac{1}{2} (\# \text{ down cusps} - \# \text{ up cusps})$$

Next, a *Legendrian ribbon* R_g for a Legendrian graph $g : G \rightarrow (M, \xi)$ is a compact, oriented surface such that

- (1) R_g contains $g(G)$ as its 1-skeleton,
- (2) ξ has no negative tangencies to R_g ,

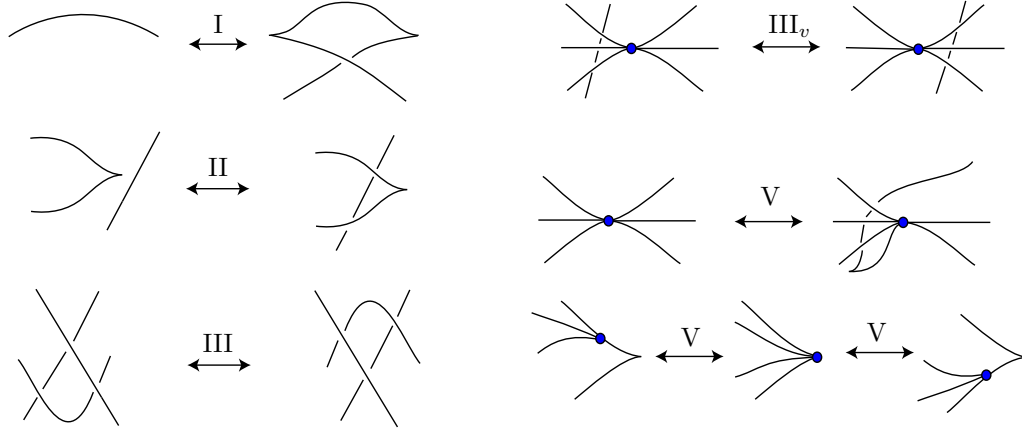

FIGURE 2. Legendrian isotopy moves for graphs in the front projection: Reidemeister moves I, II, and III, an edge passing under or over a vertex (III_v), an edge adjacent to a vertex rotates to the other side of the vertex (V). Move V is shown with edges on both sides and on one side of the vertex. Reflections of these moves that are Legendrian front projections are also allowed.

- (3) there exists a vector field X on R_g tangent to the characteristic foliation of R_g whose time- t flow ϕ_t satisfies $\cap_{t \geq 0} \phi_t(R_g) = g(G)$,
- (4) the oriented boundary of R_g is positively transverse to the contact structure ξ .

The Legendrian ribbon is unique up to ambient contact isotopy and thus an invariant of g . This gives rise to a couple more invariants. The underlying unoriented surface \bar{R}_g is the *contact framing* of g . The transverse link that forms the boundary of R_g is the *transverse pushoff* of g .

A topological knot type K is Legendrian simple if (tb, rot) are a complete set of invariants for Legendrian realizations of K . In other words, there is at most one Legendrian realization of K for each choice of (tb, rot) . Several topological knot types are known to be Legendrian simple. A few examples are the unknot, the figure-8 knot, and torus knots [EF09, EH01, DG07]. For Legendrian graphs much less is known about Legendrian simplicity. In the case of topologically trivial graphs, we have the following result:

Theorem 2.1 ([LCO16]). *Let G be a trivalent, planar graph. Then (R_g, rot_g) is a complete set of invariants for topologically trivial Legendrian embeddings $g : G \rightarrow (S^3, \xi_{\text{std}})$*

For a Legendrian knot K , different Legendrian knots in the same topological class can be obtained by stabilizations, where a single twist is added in an arc of the knot, consistent with the contact structure. This can be defined in $(\mathbb{R}^3, \xi_{\text{std}})$ with the front projection. A *stabilization* means replacing an arc in the front projection of K by one of the zig-zags in Figure 3. The stabilization is positive if the new cusps are oriented downwards and negative if the cusps are oriented upwards. The classical invariants of the stabilized knot satisfy $\text{tb}(S_{\pm}(K)) = \text{tb}(K) - 1$ and $\text{rot}(S_{\pm}(K)) = \text{rot}(K) \pm 1$. Thus stabilization changes the Legendrian isotopy class. It is a well defined operation and can be performed anywhere along a knot.

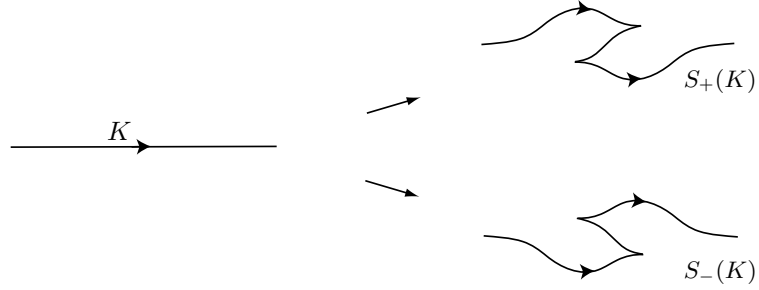

FIGURE 3. Positive and negative stabilizations in the front projection of a knot or edge

For Legendrian graphs, *edge stabilizations* along a fixed edge are defined in the same way. They can be performed at any point along a given edge but stabilizing along different edges will not be equivalent in general.

Consider the map diffeomorphism $\phi : (x, y, z) \mapsto (x, -y, -z)$ of \mathbb{R}^3 to itself. It is an orientation-preserving contactomorphism of \mathbb{R}^3 since $\phi^*(\alpha) = -\alpha$. However, it reverses the coorientation of the contact planes. If g is a Legendrian graph, the *mirror* $M(g)$ is the image of g under the map ϕ . In the front projection, this corresponds to mirroring across the x -axis.

Lemma 2.2. *Let $g : G \rightarrow (S^3, \xi_{std})$ be a Legendrian graph and let $M(g)$ be its mirror. Then*

- (1) *the embeddings g and $M(g)$ are ambient isotopic,*
- (2) *the contact framings $\overline{R}_g, \overline{R}_{M(g)}$ agree,*
- (3) *the Legendrian ribbons $R_g, R_{M(g)}$ have opposite coorientations,*
- (4) *if γ is an oriented cycle of G , then*

$$tb_{M(g)}(\gamma) = tb_g(\gamma) \quad rot_{M(g)}(\gamma) = -rot_g(\gamma)$$

Proof. The map ϕ is a rotation by π around the x -axis, so g and $M(g)$ are clearly smoothly isotopic. In addition, this rotation takes \overline{R}_g to $\overline{R}_{M(g)}$ but the coorientations on the contact framing induced by ξ_{std} differ by a sign. Finally, the rotation does not change the number of cusps or the writhe of a cycle but it does exchange up and down cusps. Thus, $tb_g(\gamma)$ is fixed but $rot_g(\gamma)$ changes sign. \square

3. CLASSIFICATION OF Θ -GRAPHS

The Θ -graph consists of two vertices v_1, v_2 and three edges e_1, e_2, e_3 . There are three cycles $\gamma_1 = e_1 \cup e_2; \gamma_2 = e_2 \cup e_3; \gamma_3 = e_3 \cup e_1$. We orient the cycle γ_i so that e_i is oriented from v_1 to v_2 . Let $\theta : \Theta \rightarrow (S^3, \xi_{std})$ be a Legendrian embedding. The Thurston-Bennequin and rotation numbers of each cycle determine vectors $\overline{tb}_\theta, \overline{rot}_\theta \in \mathbb{Z}^3$

$$\begin{aligned} \overline{tb}_\theta &:= (tb_\theta(\gamma_1), tb_\theta(\gamma_2), tb_\theta(\gamma_3)) \\ \overline{rot}_\theta &:= (rot_\theta(\gamma_1), rot_\theta(\gamma_2), rot_\theta(\gamma_3)) \end{aligned}$$

Let $Rot_\theta := rot_\theta(\gamma_1) + rot_\theta(\gamma_2) + rot_\theta(\gamma_3)$ denote the *total rotation number* of θ . It is also convenient to think of the Thurston-Bennequin invariant as a triple of half-integers assigned to each edge. Define

$$tw_\theta(e_i) = \frac{1}{2} (tb_\theta(\gamma_{i-1}) + tb_\theta(\gamma_i) - tb_\theta(\gamma_{i+1}))$$

for $i = 1, 2, 3 \pmod 3$. It follows that $\text{tb}_\theta(\gamma_i) = \text{tw}_\theta(e_i) + \text{tw}_\theta(e_{i+1})$.

Lemma 3.1. *Suppose that θ, θ' are topologically trivial Legendrian embeddings of Θ such that $\overline{\text{tb}}_\theta = \overline{\text{tb}}_{\theta'}$. Then \overline{R}_θ and $\overline{R}_{\theta'}$ are isotopic.*

Proof. Let $R_\theta, R_{\theta'}$ be the Legendrian ribbons of θ, θ' and let $\Sigma_\theta, \Sigma_{\theta'}$ be a smooth spheres containing the images of θ, θ' , respectively.

The Θ -graph is trivalent, so we can isotope R_θ and Σ_θ rel $\theta(\Theta)$ so that they agree in open neighborhoods of $\theta(v_1), \theta(v_2)$. Up to isotopy, the Legendrian ribbon R_θ can be obtained from a tubular neighborhood of $\theta(\Theta)$ in Σ_θ by adding $\text{tw}_\theta(e_i)$ half twists along the edge e_i for $i = 1, 2, 3$. $R_{\theta'}$ can be obtained from $\Sigma_{\theta'}$ similarly. Since $\overline{\text{tb}}_\theta = \overline{\text{tb}}_{\theta'}$, this implies that the underlying unoriented surfaces \overline{R}_θ and $\overline{R}_{\theta'}$ are isotopic. \square

The contact planes $\xi_{\theta(v_1)}$ and $\xi_{\theta(v_2)}$ are oriented. Define the sign of a vertex to be

$$\sigma_\theta(v) := \begin{cases} 1 & \text{if } \theta(e_1), \theta(e_2), \theta(e_3) \text{ are positively cyclically ordered in } \xi_{\theta(v)} \\ -1 & \text{if } \theta(e_1), \theta(e_2), \theta(e_3) \text{ are negatively cyclically ordered in } \xi_{\theta(v)} \end{cases}$$

Lemma 3.2. *Let θ be a topologically trivial Legendrian embedding with rotation invariant rot_θ . Then the total rotation number satisfies*

$$\text{Rot}_\theta = \frac{1}{2} (\sigma_\theta(v_1) - \sigma_\theta(v_2))$$

Proof. This is a reformulation of Lemma 2.1 in [LCO16] and Lemma 5 in [OP14]. \square

For each Legendrian unknot K , the Thurston-Bennequin and rotation numbers must satisfy

- (1) $\text{tb}(K) + |\text{rot}(K)| \leq -1$
- (2) $\text{tb}(K) + \text{rot}(K) = 1 \pmod 2$

Each cycle of a topologically trivial Legendrian θ must also satisfy these constraints. In addition, Lemma 3.2 implies that the total rotation number must satisfy

- (3) $\text{Rot}_\theta \in \{-1, 0, 1\}$

A pair $(\overline{\text{tb}}, \overline{\text{rot}})$ is *admissible* if it satisfies the above three restrictions.

Recall the set of graphs $\{G_l\}$ defined in Section 1. By abuse of notation, we let G_l denote any embedding θ whose image is G_l . Up to isotopy, there are 12 possible labelings: there are $2!$ ways to label the vertices and $3!$ ways to label the edges.

Lemma 3.3. *Fix $l \in \frac{1}{2}\mathbb{Z}_{\geq -\frac{1}{2}}$ and let θ be an embedding with image G_l . Then*

- (1) *if $\theta(e_1)$ is the top edge, then*

$$\overline{\text{tb}}_\theta = (-1, -2 - 2l, -1) \quad \text{and} \quad \overline{\text{tw}}_\theta = (l, -1 - l, -1 - l),$$

- (2) *the total rotation number satisfies*

$$\text{Rot}_\theta = 2l + 1 \pmod 2,$$

- (3) *θ is topologically trivial, and*
- (4) *θ is nondestabilizable.*

Proof. To prove (1), note that pairing the top edge with either of the remaining edges gives a cycle with 2 cusps and no crossings. The cycle composed of the bottom two edges has 2 cusps and writhe $-1 - 2l$. The edge twisting \overline{tw}_θ can now be immediately calculated from \overline{tb}_θ .

For (2), label the left vertex v_1 and right vertex v_2 and label the edges of G_l at the left vertex in ascending order. This implies that $\sigma_\theta(v_1) = 1$. If $2l = 1 \pmod 2$, then the edges are labeled in ascending order at the right vertex and so $\sigma_\theta(v_2) = 1$ as well. If $2l = 0 \pmod 2$, then $\sigma_\theta(v_2) = -1$. Thus, Lemma 3.2 implies the statement for this labeling of G_l . Transposing the labels on the vertices or on a pair of vertices modifies Rot_θ by multiplication by -1 and therefore does not change $\text{Rot}_\theta \pmod 2$.

For (3), the initial graph $G_{-\frac{1}{2}}$ is clearly topologically trivial. Moreover, twisting along the bottom 2 strands does not change the ambient isotopy class. Finally, for (4), each G_l is nondestabilizable since each edge is contained in a cycle with $\text{tb} = -1$. \square

Lemma 3.4. *For each admissible $(\overline{tb}, \overline{rot})$, there exists a stabilization of some G_l to an embedding θ such that $(\overline{tb}_\theta, \overline{rot}_\theta) = (\overline{tb}, \overline{rot})$.*

Proof. To simplify notation, define $r_i = \text{rot}(\gamma_i)$ for $i = 1, 2, 3$. The vector \overline{tb} determines a vector $\overline{tw} = (t_1, t_2, t_3)$ as described above. Up to cyclic relabeling of the edges, we can assume that $t_1 \geq t_2, t_3$. For $i = 1, 2, 3$, define

$$\begin{aligned} a_2 &:= \frac{1}{2}(-1 - \text{tb}(\gamma_1) - r_1) & b_2 &:= \frac{1}{2}(-1 - \text{tb}(\gamma_1) + r_1) \\ &= \frac{1}{2}(-1 - t_1 - t_2 - r_1) & &= \frac{1}{2}(-1 - t_1 - t_2 + r_1) \\ a_3 &:= \frac{1}{2}(-1 - \text{tb}(\gamma_3) + r_3) & b_3 &:= \frac{1}{2}(-1 - \text{tb}(\gamma_3) - r_3) \\ &= \frac{1}{2}(-1 - t_1 - t_3 + r_3) & &= \frac{1}{2}(-1 - t_1 - t_3 - r_3) \\ a_1 &:= \min(a_2, a_3) & b_1 &:= \min(b_2, b_3) \end{aligned}$$

Admissibility implies that a_i, b_i are nonnegative integers.

First, suppose that $t_1 \geq -\frac{1}{2}$. Set $l = t_1$ and let $G = G_l$ be a nondestabilizable Legendrian realization of Θ with $\text{tw}_G(e_1) = l$. As a result, by Lemma 3.3, $\text{tw}_G(e_2) = \text{tw}_G(e_3) = -1 - t_1$ and furthermore $\text{rot}_G(\gamma_1) = \text{rot}_G(\gamma_3) = 0$ since $\text{tb}_G(\gamma_1) = \text{tb}_G(\gamma_3) = -1$. Apply a_i positive stabilizations and b_i negative stabilizations to the oriented edge e_i for $i = 2, 3$. A simple computation shows that the resulting graph θ satisfies $\overline{tb}_\theta = \overline{tb}$ and $\overline{rot}_\theta = \overline{rot}$ and is the required graph.

Secondly, suppose that $t_1 < -\frac{1}{2}$. We claim that $t_1 + a_1 + b_1 \geq -\frac{1}{2}$. There are four cases to prove this, depending on the value of a_1, b_1 .

If $a_1 = a_2$ and $b_1 = b_2$, then

$$t_1 + a_1 + b_1 = t_1 + \frac{1}{2}(-2 - 2t_1 - 2t_2) = -1 - t_2 > -\frac{1}{2}$$

since $t_i \leq t_1 < -\frac{1}{2}$. A similar argument holds if $a_1 = a_3$ and $b_1 = b_3$.

If $a_1 = a_2$ and $b_1 = b_3$, then

$$\begin{aligned} 2(a_3 - a_2) &= t_2 - t_3 + r_1 + r_3 \geq 0 \\ 2(b_2 - b_3) &= t_3 - t_2 + r_1 + r_3 \geq 0 \end{aligned}$$

which implies that $r_1 + r_3 = t_2 - t_3 = 0$. So

$$t_1 + a_1 + b_1 = \frac{1}{2}(-2 - t_2 - t_3)$$

In addition, $t_2 = t_2$ and so $t_1 + a_1 + b_1 > 0$. A similar argument holds if $a_1 = a_3$ and $b_1 = b_2$.

Now, set $l = t_1 + a_1 + b_1$ and let $G = G_l$ such that $\text{tw}_G(e_1) = l$. Apply a_1 positive and b_1 negative stabilizations to e_1 and then apply $a_i - a_1$ positive and $b_i - b_1$ negative stabilizations to e_i for $i = 2, 3$. Again, a simple computation shows that the resulting graph θ satisfies $\overline{\text{tb}}_\theta = \overline{\text{tb}}$ and $\overline{\text{rot}}_\theta = \overline{\text{rot}}$ and is the required graph. \square

Lemma 3.5. *Let $(\overline{\text{tb}}, \overline{\text{rot}})$ be admissible. If $\text{Rot} = 0$, then there exists two inequivalent Legendrian embeddings θ_+, θ_- satisfying $\overline{\text{tb}} = \overline{\text{tb}}_{\theta_+} = \overline{\text{tb}}_{\theta_-}$ and $\overline{\text{rot}} = \overline{\text{rot}}_{\theta_+} = \overline{\text{rot}}_{\theta_-}$.*

Proof. By Lemma 3.4, there exists some Legendrian embedding θ_+ with $\overline{\text{tb}}_{\theta_+} = \overline{\text{tb}}$ and $\overline{\text{rot}}_{\theta_+} = \overline{\text{rot}}$. It is obtained from some G_l by performing p_i positive and n_i negative stabilizations along the edge e_i for $i = 1, 2, 3$. See Figure 4. Let h be the graph obtained by instead performing n_i positive and p_i negative stabilizations along the edge e_i for $i = 1, 2, 3$. Consequently, $\overline{\text{tb}}_{\theta_+} = \overline{\text{tb}}_h$ and since $\text{Rot}_{\theta_+} = 0$, this also implies that $\overline{\text{rot}}_h = -\overline{\text{rot}}_{\theta_+}$. Let $\theta_- = M(h)$ be the mirror of h . Mirroring preserves $\overline{\text{tb}}$ and switches the sign of the rotation number of each cycle. Thus $\overline{\text{tb}}_{\theta_-} = \overline{\text{tb}}_{\theta_+}$ and $\overline{\text{rot}}_{\theta_-} = \overline{\text{rot}}_{\theta_+}$.

We can perform these stabilizations away from the vertices, so we can assume that R_{θ_+} and R_h agree near the vertices and thus have the same coorientation. In addition, since $\overline{\text{tb}}_{\theta_+} = \overline{\text{tb}}_h$ and both θ_+ and h are topologically trivial, there is a smooth isotopy of θ_+ to h taking R_{θ_+} to R_h . The ribbon R_{θ_-} is smoothly isotopic to R_h but has the opposite coorientation. Thus, θ_+ and θ_- are distinguished by their Legendrian ribbons. \square

Lemma 3.6. *Let $\theta_1, \theta_2 : \Theta \rightarrow (S^3, \xi_{std})$ be topologically trivial with the same $\overline{\text{tb}}, \overline{\text{rot}}$ and such that $\text{Rot}_{\theta_i} = \pm 1$. Then θ_1 and θ_2 are Legendrian isotopic.*

Proof. If $\overline{\text{tb}}_{\theta_1} = \overline{\text{tb}}_{\theta_2}$, then by Lemma 3.1 the contact framings \overline{R}_{θ_1} and \overline{R}_{θ_2} agree. Since $\overline{\text{rot}}_{\theta_1} = \overline{\text{rot}}_{\theta_2}$, Theorem 2.1 implies that only the coorientation on the contact framing distinguishes the two embeddings.

By Lemma 3.2

$$\text{Rot}_{\theta_1} = \frac{1}{2}(\sigma_{\theta_1}(v_1) - \sigma_{\theta_1}(v_2)) = \pm 1$$

However, if R_{θ_1} and R_{θ_2} have opposite coorientations, then $\sigma_{\theta_2}(v) = -\sigma_{\theta_1}(v)$ for each vertex and so

$$\text{Rot}_{\theta_2} = -\frac{1}{2}(\sigma_{\theta_1}(v_1) - \sigma_{\theta_1}(v_2)) = \mp 1$$

which is a contradiction. Thus R_{θ_1} and R_{θ_2} must have the same coorientation and therefore Theorem 2.1 implies that θ_1, θ_2 are isotopic. \square

Proposition 3.7. *Every topologically trivial Legendrian embedding $\theta : \Theta \rightarrow (S^3, \xi_{std})$ is a stabilization of some G_l .*

Proof. Let θ be such a graph. Note that Theorem 2.1 and Lemma 3.1 together imply that there are at most 2 Legendrian graphs with the same $\overline{\text{tb}}, \overline{\text{rot}}$. If $\text{Rot}_\theta = 0$, then θ must be one of the two constructed in Lemma 3.5. If $\text{Rot}_\theta = \pm 1$, then Lemma 3.6 implies θ must be Legendrian isotopic to the one constructed in Lemma 3.4. \square

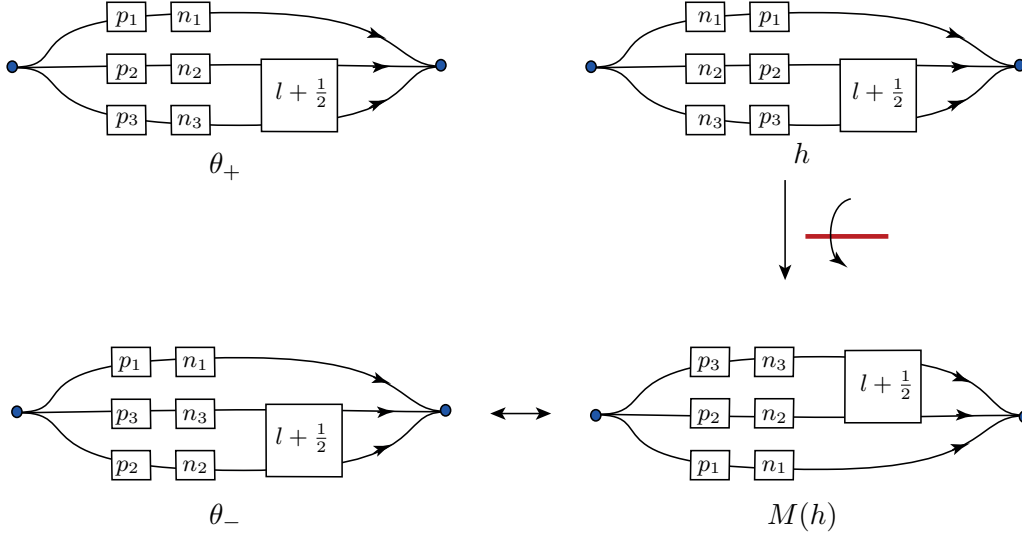

FIGURE 4. The graph θ_+ (top left) is obtained from G_l by applying p_i positive and n_i negative stabilizations along e_i . Our convention is that the left box denote positive stabilizations and the right box denotes negative stabilizations. See Figure 5. The graph h (top right) is obtained from G_l by instead applying n_i positive and p_i negative stabilizations. The mirror of h (bottom right) is obtained by rotation around the x -axis. Note that a positive zigzag in h becomes a negative zigzag in $M(h)$. These commute so we can move the n_i positive stabilizations to the left by a Legendrian isotopy. By a Legendrian isotopy, we can move the bottom strand of $M(h)$ to the top and obtain θ_- (bottom left). If $\text{Rot}_{\theta_+} = 0$, then θ_+ and θ_- have the same invariants $\overline{\text{tb}}, \overline{\text{rot}}$.

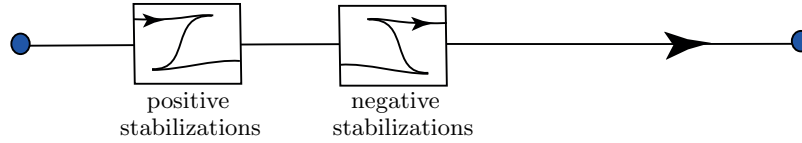

FIGURE 5. In Figure 4, our convention is to let the left box denote positive stabilizations and the right box denote negative stabilizations.

Corollary 3.8. *The set of nondestabilizable, topologically trivial Legendrian Θ -graphs is precisely $\{G_l\}_{l \geq -\frac{1}{2}}$.*

Theorem 2.1 combined with Lemmas 3.5 and 3.6 classify topologically trivial Legendrian embeddings of Θ . We now address the classification of the images of these embeddings.

Relabeling the edges and vertices of the image $\theta(\Theta)$ corresponds to replacing θ with $\theta \circ \phi$ for some $\phi \in \text{Aut}(\Theta)$. The automorphisms of Θ are permutations of the vertices and edges and so the automorphism group is $S_2 \times S_3$. Under ϕ , the image or orientation of a cycle may change and so the invariants $\overline{\text{tb}}_\theta, \overline{\text{rot}}_\theta$ change as well after relabeling.

Let ϕ_v denote the automorphism that fixes the edges and swaps the vertices and let ϕ_i denote the automorphism that fixes the vertices and transposes the edges e_i, e_{i+1} . The four automorphisms $\{\phi_v, \phi_1, \phi_2, \phi_3\}$ generate $\text{Aut}(\Theta)$. The automorphism ϕ_v acts by reversing the orientation on cycles

$$\phi_v(\gamma_j) = -\gamma_j \text{ for } j = 1, 2, 3$$

and for $i = 1, 2, 3$, the automorphism ϕ_i acts on the set of oriented cycles by

$$\phi_i(\gamma_i) = -\gamma_i \quad \phi_i(\gamma_{i\pm 1}) = -\gamma_{i\mp 1}$$

To describe this effect on $\overline{\text{tb}}, \overline{\text{rot}}$, we describe the induced representation ρ of $\text{Aut}(\Theta)$ on \mathbb{Z}^6 . This representation is defined so that for every $\phi \in \text{Aut}(\Theta)$, the classical invariants satisfy

$$(\overline{\text{tb}}_{\theta \circ \phi}, \overline{\text{rot}}_{\theta \circ \phi}) = \rho(\phi) \cdot (\overline{\text{tb}}_\theta, \overline{\text{rot}}_\theta)$$

Let I_k denote the trivial representation of S_k on \mathbb{Z}^3 , i.e. $\rho(\tau)$ is the identity for all τ . Let Sgn_k denote the sign representation of S_k on \mathbb{Z}^3 , i.e. $\rho(\tau)$ is multiplication by the sign of the permutation τ . Let p_ζ denote the shifted permutation representation of S_3 on \mathbb{Z}^3 , i.e. if τ_i is an elementary transposition in S_3 swapping i and $i+1$, then $p_\zeta(\tau_i)$ transposes the coordinates z_{i+1}, z_{i+2} . Define representations ρ_2, ρ_3 of S_2, S_3 , respectively, on \mathbb{Z}^6 by

$$\begin{aligned} \rho_2 &:= I_2 \oplus \text{Sgn}_2 \\ \rho_3 &:= (I_3 \oplus \text{Sgn}_3) \cdot (p_\zeta \oplus p_\zeta) \end{aligned}$$

and extend to a representation $\rho = \rho_2 \times \rho_3$ of $S_2 \times S_3$. Identifying $\text{Aut}(\Theta)$ with $S_2 \times S_3$ and viewing $(\overline{\text{tb}}, \overline{\text{rot}}) = (\text{tb}_1, \text{tb}_2, \text{tb}_3, \text{rot}_1, \text{rot}_2, \text{rot}_3)$ as a vector in \mathbb{Z}^6 , we see that

$$\begin{aligned} \rho(\phi_v) \cdot (\text{tb}_1, \text{tb}_2, \text{tb}_3, \text{rot}_1, \text{rot}_2, \text{rot}_3) &= (\text{tb}_1, \text{tb}_2, \text{tb}_3, -\text{rot}_1, -\text{rot}_2, -\text{rot}_3) \\ \rho(\phi_1) \cdot (\text{tb}_1, \text{tb}_2, \text{tb}_3, \text{rot}_1, \text{rot}_2, \text{rot}_3) &= (\text{tb}_1, \text{tb}_3, \text{tb}_2, -\text{rot}_1, -\text{rot}_3, -\text{rot}_2) \\ \rho(\phi_2) \cdot (\text{tb}_1, \text{tb}_2, \text{tb}_3, \text{rot}_1, \text{rot}_2, \text{rot}_3) &= (\text{tb}_3, \text{tb}_2, \text{tb}_1, -\text{rot}_3, -\text{rot}_2, -\text{rot}_1) \\ \rho(\phi_3) \cdot (\text{tb}_1, \text{tb}_2, \text{tb}_3, \text{rot}_1, \text{rot}_2, \text{rot}_3) &= (\text{tb}_2, \text{tb}_1, \text{tb}_3, -\text{rot}_2, -\text{rot}_1, -\text{rot}_3) \end{aligned}$$

From the above discussion, it follows that this is the correct effect of the classical invariants.

Proposition 3.9. *Suppose that θ, θ' are topologically trivial Legendrian Θ -graphs such that*

$$\rho(\phi) \cdot (\overline{\text{tb}}_\theta, \overline{\text{rot}}_\theta) = (\overline{\text{tb}}_{\theta'}, \overline{\text{rot}}_{\theta'})$$

for some $\phi \in \text{Aut}(\Theta)$. Then

- (1) If $\text{Rot}_\theta, \text{Rot}_{\theta'} \neq 0$ then θ, θ' are Legendrian isotopic up to relabeling.
- (2) If $\text{Rot}_\theta, \text{Rot}_{\theta'} = 0$, then θ, θ' are Legendrian isotopic up to relabeling if and only if either
 - (a) $\sigma_{\theta \circ \phi}(v_1) = \sigma_{\theta'}(v_1)$, or
 - (b) there is a transposition $\tau \in S_3$ such that $\rho_3(\tau)$ fixes $(\overline{\text{tb}}_{\theta'}, \overline{\text{rot}}_{\theta'})$.

Proof. First, suppose that $\text{Rot}_\theta, \text{Rot}_{\theta'} \neq 0$. Then by assumption $(\overline{\text{tb}}_{\theta \circ \phi}, \overline{\text{rot}}_{\theta \circ \phi}) = (\overline{\text{tb}}_{\theta'}, \overline{\text{rot}}_{\theta'})$ and so by Lemma 3.6, the graphs $g \circ \phi$ and h are Legendrian isotopic.

Second, suppose that $\text{Rot}_\theta = \text{Rot}_{\theta'} = 0$. If $\sigma_{\theta \circ \phi}(v_1) = \sigma_{\theta'}(v_1)$, then the Legendrian ribbons $R_{\theta \circ \phi}$ and $R_{\theta'}$ have the same coorientation, and by Theorem 2.1, $g \circ \phi$ and h are Legendrian isotopic.

Instead, suppose that $\sigma_{\theta \circ \phi}(v_1) \neq \sigma_{\theta'}(v_1)$. If the required transposition τ exists, then $(\overline{\text{tb}}_{\theta \circ \phi}, \overline{\text{rot}}_{\theta \circ \phi}) = (\overline{\text{tb}}_{\theta' \circ \tau}, \overline{\text{rot}}_{\theta' \circ \tau})$ and since τ is an odd permutation, $\sigma_{\theta \circ \phi}(v_1) = \sigma_{\theta' \circ \tau}(v_1)$ and so $\theta \circ \phi$ and $\theta' \circ \tau$ are Legendrian isotopic. Conversely, θ and h are isotopic up to relabeling if and only if there exists some automorphism ψ such that $\theta \circ \phi \circ \psi$ and θ' are Legendrian isotopic. In particular, this means that

$\sigma_{\theta \circ \phi \circ \psi}(v_1) = \sigma_{\theta'}(v_1)$. Consequently, ψ must be an odd permutation in S_3 and the odd permutations of S_3 are exactly the transpositions. \square

4. GRAPH MOVES AND STABILIZATIONS

In this section we introduce two moves between different Legendrian graphs, and show how the G_l graphs are related by these moves.

Fuchs and Tabachnikov [FT97] showed that if L_1, L_2 are Legendrian knots that are topologically isotopic, then they are Legendrian isotopic after applying a sequence of stabilizations. This is not the case for Legendrian graphs, stabilizations along edges of Legendrian graphs are not a sufficient collection of moves to accomplish this. Recall, for Legendrain graphs stabilization is defined in a similar way and can happen on any edge. A simple example of Legendrian graphs that are not related by are the pair Legendrian Θ -graphs $G_{-\frac{1}{2}}$ and G_0 . These two graphs have a different cyclic ordering of the edges around one of the vertices. There is no way to changed the cyclic ordering at a vertex with only edge stabilizations. Here we will define two new moves: vertex stabilization and vertex twist.

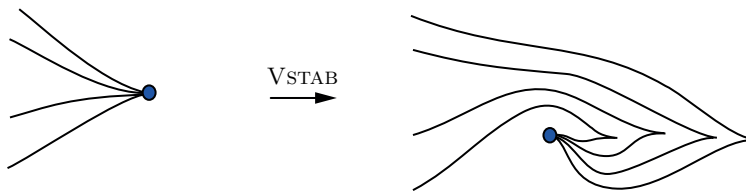

FIGURE 6. A vertex stabilization in the front projection on a valence 4 vertex.

Definition 4.1. A *vertex stabilization* is defined for vertices of valence 3 or more, by front projection diagrams shown in Figure 6; here the neighborhood of a vertex is replaced with a vertex and arcs where a half stabilization is introduced to each edge.

Figure 6 shows a stabilization of a valence 4 vertex. Vertex stabilization reverses the cyclic order of edges around the vertex in the contact plane. Note that in a neighborhood of a vertex, all edges can be moved to the left using Reidemeister V moves.

Remark 4.1. The choice to have the edges kind downwards rather than upwards is inconsequential. In Figure 7 we show a sequence of Legendrian graph Reidemeister moves to go from the standard vertex stablization form to a braided representation. From the braided form one can move in a similar way to the projection with all edges kinked the other way.

Observation 4.2. Vertex stabilization is not intrinsic to the vertex itself. The front diagram picks out the top and bottom edges as a distinguished pair of edges. The Legendrian isotopy class of the resulting graph depends on this distinguished pair. By Reidemeister moves, we can cyclically rotate the edges as in Figure 8 and then apply a vertex stabilization. However, this is not Legendrian isotopic to the original vertex stabilization.

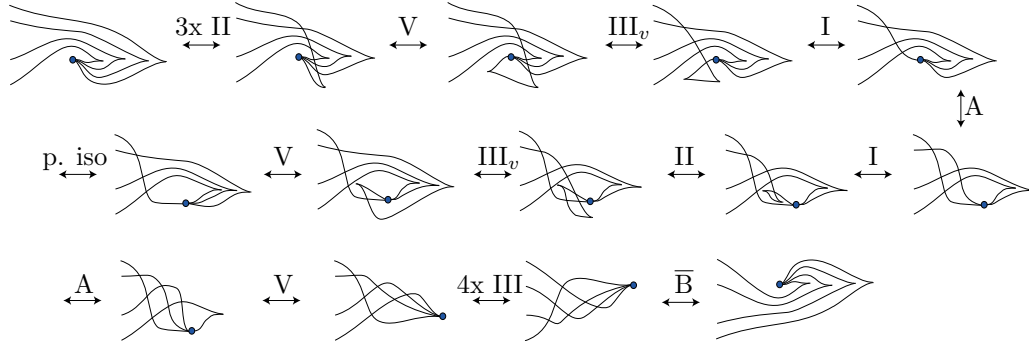

FIGURE 7. Moving between the standard projection of a vertex stabilization, the braided form, and the mirrored projection. The double sided arrows indicate Legendrian graph Reidemeister moves, sets of Legendrian graph Reidemeister moves, or planar isotopy. The set of moves in the second row (together called A), shows how to move a edge e_i ($i \neq 1, n$) into the braid formation. The set of moves to get from the standard projection of a vertex stabilization, the braided form (shown third from the end) we will call B. The symbol \bar{B} is the similar set of Legendrian graph Reidemeister moves going from our mirrored braid to the mirrored projection.

To see this, let the edges incident to v be labeled e_i , starting with the top edge and going to the bottom (clockwise in the cyclic ordering). Let α_i be the arc e_i followed by e_{i+1} , and α_n be the arc e_n followed by e_1 . This gives an orientation on the arcs, where each edge with each orientation. After the vertex stabilization the arcs α_i with $i = 1, \dots, n - 1$ will be negatively stabilized and the arc α_n will be positively stabilized. See Figure 9. In particular, any cycle containing the distinguished pair of edges will be stabilized with the opposite sign.

Thus, for a valence n vertex, there are n different possible vertex stabilizations. See Figure 10

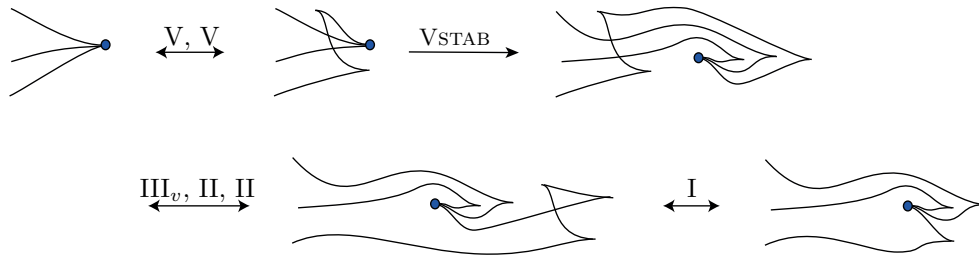

FIGURE 8. Obtaining the second type of vertex stabilization $S_2(v)$ using only the vertex stabilization move and Reidemeister moves.

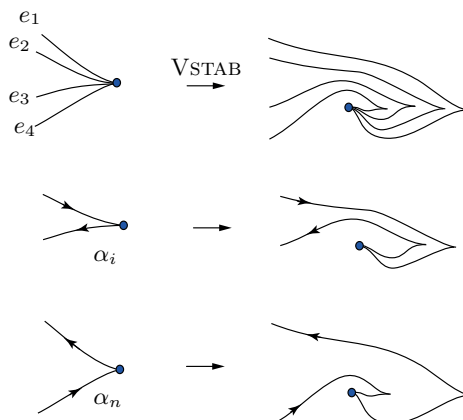

FIGURE 9. The top row shows vertex stabilization on a 4 valent vertex, the lower two show how the arcs defined by pairs of edges are changed under vertex stabilization. With the edges labeled as indicated, let α_i be the arc e_i followed by e_{i+1} (for $i = 1, 2, 3$), and α_n be the arc e_4 followed by e_1 .

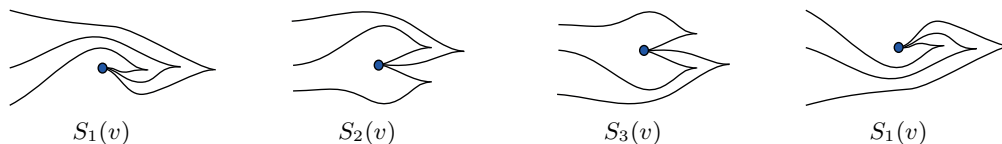

FIGURE 10. The three different stabilizations for a trivalent vertex. The equivalence of the first and last projections is shown in Figure 7.

The different vertex stabilizations are obtained by having a different pair of edges in the top and bottom positions. Any pair of neighboring edges can be moved to these positions using Reidemeister V moves. Figure 10 shows the three different vertex stabilizations for a trivalent vertex. Figure 8 shows how to obtain the second stabilization $S_2(v)$ through Reidemeister moves and the vertex stabilization. Thus the single move shown in Figure 6 for valence n vertices ($n \geq 3$), together with the Legendrian graph Reidemeister moves gives all possible vertex stabilizations.

Definition 4.2. A *vertex twist* is defined for vertices of valence 3 or more, by front projection diagrams shown in Figure 11; here the neighborhood of a vertex is replaced with a vertex and arcs where two neighboring edges have switched cyclic ordering around the vertex and one edge crosses over the other as shown.

Remark 4.3. If we restrict to trivalent graphs the vertex twist is redundant. Both positive and negative vertex twists can be obtained by a vertex stabilization, an edge destabilization, and Reidemeister moves. See Figure 12.

Now that we have defined all of the moves on Legendrian graphs, we will look at how the G_i 's are related by such moves.

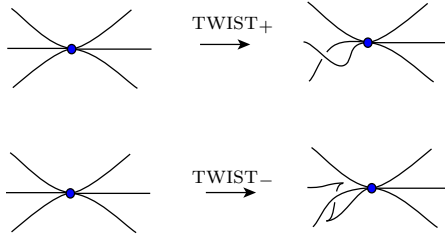

FIGURE 11. Positive and negative vertex twist.

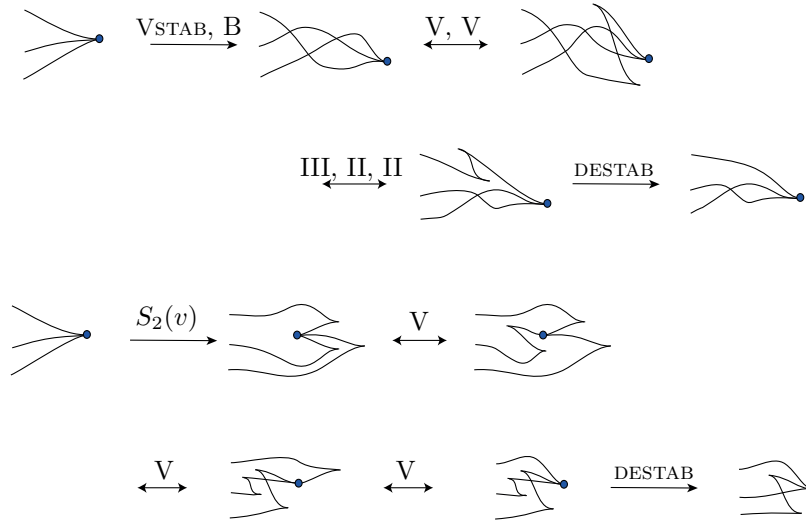

FIGURE 12. Obtaining the vertex twist moves for trivalent vertices, through vertex stabilization, an edge destabilization, and Reidemeister moves.

Lemma 4.4. *The graph $G_{l+\frac{1}{2}}$ can be obtained from G_l by a vertex stabilization and then an edge destabilization.*

Proof. Consider an arbitrary G_l , as shown in Figure 13. A vertex stabilization is done on the right-most vertex, and is moved to braid form. Then Reidemeister moves are done as indicated to move to a $G_{l+\frac{1}{2}}$ with the distinguished edge stabilized. This completes the lemma. \square

Lemma 4.5. *The graph $G_{l'}$ can be obtained from G_l by a sequence of an edge stabilization (or destabilization) if and only if $l - l' \in \mathbb{Z}$.*

Proof. Suppose that $l - l'$ were not an integer, then Lemma 4 they are related by an odd number of vertex stabilizations and some edge destabilizations. Since they are related by an odd number of vertex

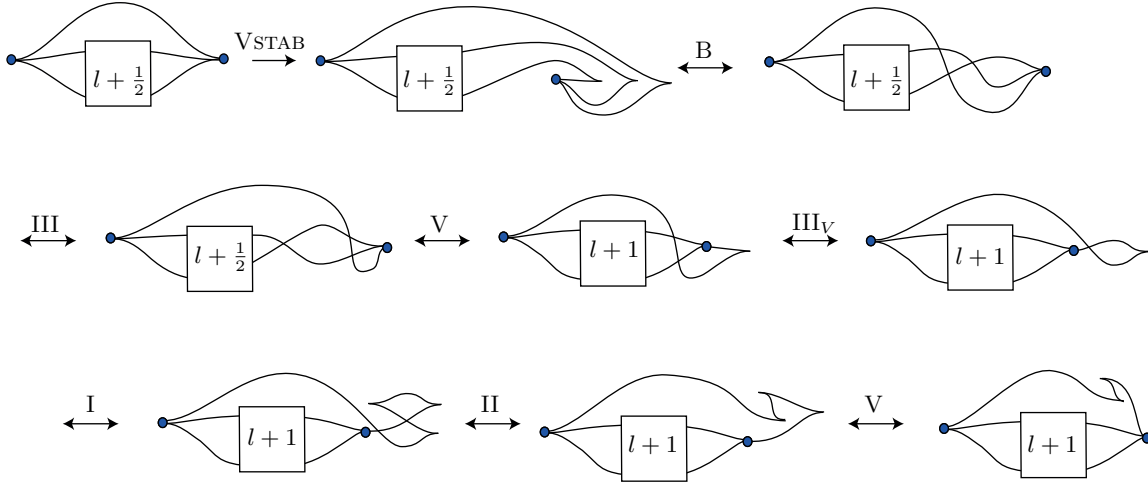

FIGURE 13. The result of a single vertex stabilization on G_l . The first arrow shows a vertex stabilization. The double sided arrows indicate Legendrian graph Reidemeister moves or sets of Legendrian graph Reidemeister moves. The symbol \mathbf{B} is for the set of Legendrian graph Reidemeister moves need to move from the standard front projection of a vertex stabilization to the braided form. See Figure 7.

destabilizations, the two graphs have a different cyclic ordering of the edges around one of the vertices. Thus they cannot be related by edge stabilization / destabilization.

Now suppose $l - l' \in \mathbb{Z}$. Without loss of generality suppose $l < l'$. Consider an arbitrary G_l , as shown in Figure 14. Two edge stabilizations are done on the lower two edges. Then Reidemeister moves are done as indicated to move to a G_{l+1} with the distinguished edge stabilized. This edge can be destabilized to obtain G_{l+1} . This process is repeated to obtain $G_{l'}$ from G_l . \square

5. NONDESTABILIZABLE GRAPHS

In this subsection, we prove that a planar graph has infinitely many nondestabilizable realizations if it contains a subdivision of Θ or $S^1 \vee S^1$ as a subgraph. The proof implicitly uses convex surface theory, although we will not use the full theory here. The only fact we require is the following instance of the Legendrian Realization Principle [Hon00a].

Proposition 5.1 (Legendrian Realization Principle). *Let S be the unit sphere in $(\mathbb{R}^3, \xi_{std})$, let $\Gamma = S \cap \{z = 0\}$ be the equator of S , and let G be a graph embedded on S . Then there exists a C^∞ small perturbation ϕ of S , fixing Γ , such that $\phi(G)$ is Legendrian. In addition, if γ is a cycle of G then $tb(\gamma) = -\frac{1}{2}\#(\gamma \cap \Gamma)$.*

Let $g : G \rightarrow (M, \xi)$ be a Legendrian embedding. The graph g has *Property N* if each edge is either (1) a cut edge, or (2) contained in a nondestabilizable cycle.

Proposition 5.2. *Let $g : G \rightarrow (M, \xi)$ be a Legendrian graph. If g has Property N, then g is nondestabilizable.*

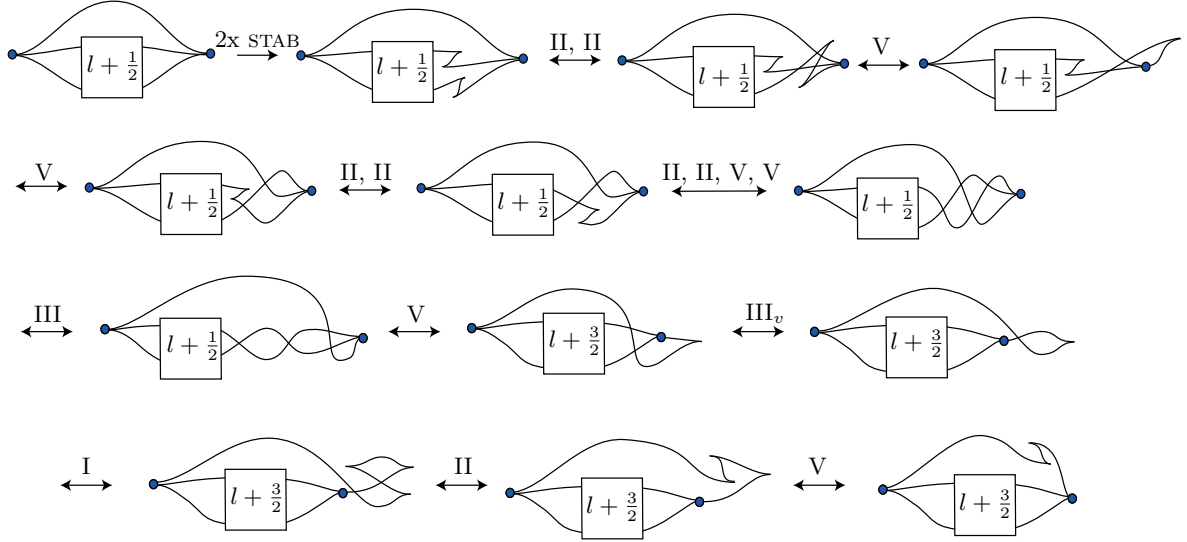

FIGURE 14. Moving between G_l and G_{l+1} with a stabilized edge. The first arrow shows two edge stabilizations. The double sided arrows indicate Legendrian graph Reidemeister moves or sets of Legendrian graph Reidemeister moves as indicated.

Proof. If g admits a destabilization along e , then every cycle containing e admits a destabilization. \square

An edge e (respectively vertex v) of a connected graph G is a *cut edge* (respectively *cut vertex*) if $G \setminus e$ ($G \setminus v$) is disconnected.

Proposition 5.3. *Let G be an abstract planar graph. Then there exists a topologically trivial Legendrian embedding $g : G \rightarrow (S^3, \xi_{std})$ that has Property N.*

Proof. Fix an embedding of G in S^2 and let G^* be the dual graph of G in S^2 . Choose a spanning tree T^* for G^* and let Γ be the boundary of a tubular neighborhood of T^* in S^2 . Choose a map $S^2 \rightarrow S$ that sends Γ to the equator of S , the unit sphere in $(\mathbb{R}^3, \xi_{std})$. By the Legendrian Realization Principle (Proposition 5.1), a perturbation gives a topologically trivial Legendrian embedding g of G .

In order to show that g has Property N, we need to show that every non-cut edge is contained in a nondestabilizable cycle. By Proposition 5.1 and the classification of Legendrian unknots, this requires that each non-cut edge is contained in a cycle γ satisfying $\#\gamma \cap \Gamma = -2\text{tb}_g(\gamma) = 2$. By the construction of Γ , this implies that among all the edges comprising the cycle γ , exactly 1 corresponding dual edge is contained in the spanning tree T^* .

Fix a root vertex F_{root}^* . For each face F^* define $l(F^*)$ to be the length of the unique path in T^* from F_{root}^* to F^* . Let m denote the maximal length of any such path. For each face F^* , define $d(F^*) = m - l(F^*)$. We will prove that every edge in the boundary of every face is either a cut edge or contained in a cycle with $\text{tb} = -1$ by induction on d .

Let F be a face such that $d(F^*) = 0$. Then F^* is a leaf of T^* . In addition, since F^* is leaf of T^* , it cannot be a cut vertex of G^* . Let \bar{F} be the closure of the corresponding face F . The domain \bar{F} must be a topological disk, since if it has multiple boundary components then F^* is a cut vertex of G^* . Then

for each edge $e \in \partial F$, either e is a cut edge or e lies in $\partial \bar{F}$. Let $\gamma = \partial \bar{F}$. The cycle γ contains exactly 1 edge whose dual lies in T^* since F^* is a leaf of T^* . Therefore all edges in ∂F satisfy the condition.

Now, let F be a face such that $d(F^*) = i > 0$ and suppose that all edges in the boundary of a face F with $d(F^*) \leq i - 1$ are either cut edges or contained in a cycle with $\text{tb} = -1$. If $F^* = F_{root}^*$, then every edge in the boundary of F is either a cut edge or incident to another face F' . Since $d(F_{root}^*) > d((F')^*)$, by induction all non-cut edges in ∂F are contained in a cycle of $\text{tb} = -1$.

Suppose instead that $F^* \neq F_{root}^*$. Removing F^* from T^* splits T^* into two components, one containing the root F_{root}^* and one containing faces with $d((F')^*) < i$. Let D be the union of the latter set of faces with F . Let \bar{D} be the closure of the union of the faces of D . This domain must be a topological disk since otherwise the complement of the union of the dual faces in G^* would have multiple components. Let $\gamma = \partial \bar{D}$ and let e be an edge in ∂F . Then either (1) $e \in \gamma$, (2) e is a cut edge, or (3) e connects F to some other face F_j in D . In the first two cases, it's clear that e lies in a cycle with $\text{tb} = -1$ or is a cut edge. Finally, if (3), then by induction since $d(F') < i$ then e lies in some other cycle with $\text{tb} = -1$. \square

Theorem 1.2. *Let G be an abstract planar graph that contains a subdivision of Θ or $S^1 \vee S^1$ as a subgraph. Then there exists infinitely many, pairwise-distinct, topologically trivial Legendrian embeddings $g : G \rightarrow (S^3, \xi_{std})$.*

Proof. First suppose that G contains a subdivision of Θ as a subgraph. Fix an embedding of G in S^2 . We can choose two vertices v_1, v_2 and three vertex-independent paths p_1, p_2, p_3 from v_1 to v_2 . Since G is planar, then after possibly replacing v_1, v_2, p_1, p_2, p_3 , we can assume that v_1, v_2, p_2, p_3 all lie in the boundary of some fixed face F . Let e_i denote the edge of p_i incident to v_1 . After possibly modifying the embedding of G in S^2 , we can assume that e_2, e_3 are adjacent in the cyclic ordering of edges incident to v_1 .

Since p_2, p_3 are vertex-independent, the dual face F^* is not a leaf of G^* . In addition, we can choose a spanning tree T^* of G^* containing e_2^* and e_3^* . Now, using the argument of Proposition 5.3, we can use the spanning tree T^* to construct a topologically trivial Legendrian embedding g of G with Property N. Moreover, since $e_2^*, e_3^* \in T^*$, every cycle γ containing both e_2 and e_3 must have $\text{tb}_g(\gamma) \leq -2$.

Let g_k denote the graph obtained by performing k positive vertex twists of e_2 and e_3 at v_1 . This is allowed since e_2, e_3 are adjacent at v_1 . If γ is a cycle that does not contain both e_2 and e_3 , then $g_k(\gamma)$ is Legendrian isotopic to $g(\gamma)$. Consequently, if γ is a cycle with $\text{tb}_g(\gamma) = -1$ then $\text{tb}_{g_k}(\gamma) = -1$ as well. This implies that each g_k has Property N and is nondestabilizeable. However, if γ is a cycle containing both e_2 and e_3 , then $\text{tb}_g(\gamma) - \text{tb}_{g_k}(\gamma) = k$. Thus, the Legendrian graphs $\{g_k\}$ are pairwise distinct.

Second, suppose that G contains a subdivision of $S^1 \vee S^1$ as a subgraph and does *not* contain a subdivision of Θ as a subgraph. Thus, there is a vertex v and two vertex-independent paths p_1, p_2 from v to itself. Since G does not contain a subdivided Θ , every edge incident to v either lies in a unique path from v to v or is a cut edge. After possibly replacing the vertex and paths v, p_1, p_2 and the embedding of G in S^2 , we can assume that there exists edges e_1, e_2 that are consecutive in the cyclic ordering at v and such that e_i lies in p_i .

By a similar argument as above, we can find a nondestabilizeable Legendrian embedding g of G . Let g_k be the Legendrian graph obtained by performing $2k$ positive vertex twists of e_1, e_2 . Again, each g_k is nondestabilizeable. To distinguish these embeddings, we show that they have distinct contact framings. Let \tilde{g}_k denote the restriction of g_k to the subgraph $S^1 \vee S^1$. The Legendrian ribbon $R_{\tilde{g}_k}$ has a transverse pushoff T_k with 3 components T_k^1, T_k^2, T_k^3 . See Figure 15. The linking number of T_k^2

with T_k^3 is k . This implies that the embeddings $\{\tilde{g}_k\}$ and therefore the embeddings $\{g_k\}$ are pairwise distinct. \square

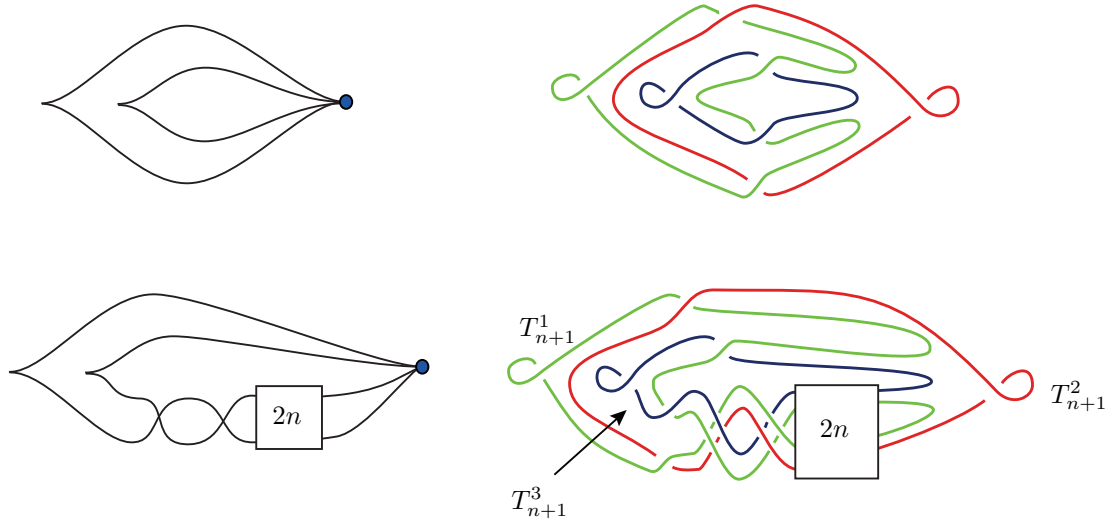

FIGURE 15. On the left is a Legendrian embedding of $S^1 \vee S^1$ with both cycles maximal unknots (top) and the result of applying $2n+2$ vertex twists to the bottom two strands. On the right are the transverse pushoffs of these graphs. For all n , the transverse pushoff has 3 components and the linking number of T_{n+1}^2 and T_{n+1}^3 is $n+1$.

REFERENCES

- [Ben83] Daniel Bennequin. Entrelacements et équations de Pfaff. In *Third Schnepfenried geometry conference, Vol. 1 (Schnepfenried, 1982)*, volume 107 of *Astérisque*, pages 87–161. Soc. Math. France, Paris, 1983.
- [BI09] Sebastian Baader and Masaharu Ishikawa. Legendrian graphs and quasipositive diagrams. *Ann. Fac. Sci. Toulouse Math. (6)*, 18(2):285–305, 2009.
- [BW00] Joan S. Birman and Nancy C. Wrinkle. On transversally simple knots. *J. Differential Geom.*, 55(2):325–354, 2000.
- [Che02] Yuri Chekanov. Differential algebra of Legendrian links. *Invent. Math.*, 150(3):441–483, 2002.
- [DG07] Fan Ding and Hansjörg Geiges. Legendrian knots and links classified by classical invariants. *Commun. Contemp. Math.*, 9(2):135–162, 2007.
- [EF09] Yakov Eliashberg and Maia Fraser. Topologically trivial Legendrian knots. *J. Symplectic Geom.*, 7(2):77–127, 2009.
- [EH01] John B. Etnyre and Ko Honda. Knots and contact geometry. I. Torus knots and the figure eight knot. *J. Symplectic Geom.*, 1(1):63–120, 2001.
- [Eli92] Yakov Eliashberg. Contact 3-manifolds twenty years since J. Martinet’s work. *Ann. Inst. Fourier (Grenoble)*, 42(1-2):165–192, 1992.
- [Eli93] Yakov Eliashberg. Legendrian and transversal knots in tight contact 3-manifolds. In *Topological methods in modern mathematics (Stony Brook, NY, 1991)*, pages 171–193. Publish or Perish, Houston, TX, 1993.
- [ENV13] John B. Etnyre, Lenhard L. Ng, and Vera Vértési. Legendrian and transverse twist knots. *J. Eur. Math. Soc. (JEMS)*, 15(3):969–995, 2013.
- [Etn99] John B. Etnyre. Transversal torus knots. *Geom. Topol.*, 3:253–268 (electronic), 1999.
- [FT97] Dmitry Fuchs and Serge Tabachnikov. Invariants of Legendrian and transverse knots in the standard contact space. *Topology*, 36(5):1025–1053, 1997.
- [Gir91] Emmanuel Giroux. Convexité en topologie de contact. *Comment. Math. Helv.*, 66(4):637–677, 1991.

- [Gir93] Emmanuel Giroux. Topologie de contact en dimension 3 (autour des travaux de Yakov Eliashberg). *Astérisque*, (216):Exp. No. 760, 3, 7–33, 1993. Séminaire Bourbaki, Vol. 1992/93.
- [Gir00] Emmanuel Giroux. Structures de contact en dimension trois et bifurcations des feuilletages de surfaces. *Invent. Math.*, 141(3):615–689, 2000.
- [HKM07] Ko Honda, William H. Kazez, and Gordana Matić. Right-veering diffeomorphisms of compact surfaces with boundary. *Invent. Math.*, 169(2):427–449, 2007.
- [Hon00a] Ko Honda. On the classification of tight contact structures. I. *Geom. Topol.*, 4:309–368, 2000.
- [Hon00b] Ko Honda. On the classification of tight contact structures. II. *J. Differential Geom.*, 55(1):83–143, 2000.
- [Kan98] Yutaka Kanda. On the Thurston-Bennequin invariant of Legendrian knots and nonexactness of Bennequin's inequality. *Invent. Math.*, 133(2):227–242, 1998.
- [Kau89] Louis H. Kauffman. Invariants of graphs in three-space. *Trans. Amer. Math. Soc.*, 311(2):697–710, 1989.
- [LCO16] Peter Lambert-Cole and Danielle O'Donnol. Planar Legendrian graphs. 2016.
- [Mas69] W. K. Mason. Homeomorphic continuous curves in 2-space are isotopic in 3-space. *Trans. Amer. Math. Soc.*, 142:269–290, 1969.
- [Ng03] Lenhard L. Ng. Computable Legendrian invariants. *Topology*, 42(1):55–82, 2003.
- [OP12] Danielle O'Donnol and Elena Pavelescu. On Legendrian graphs. *Algebr. Geom. Topol.*, 12(3):1273–1299, 2012.
- [OP14] Danielle O'Donnol and Elena Pavelescu. Legendrian θ -graphs. *Pacific J. Math.*, 270(1):191–210, 2014.
- [OP16] Danielle O'Donnol and Elena Pavelescu. The total Thurston-Bennequin number of complete and complete bipartite Legendrian graphs. In *Advances in the Mathematical Sciences*, Association for Women in Mathematics. Springer, 2016. to appear.
- [Tan15] Toshifumi Tanaka. On the maximal Thurston-Bennequin number of knots and links in spatial graphs. *Topology Appl.*, 180:132–141, 2015.
- [Whi32] Hassler Whitney. Congruent Graphs and the Connectivity of Graphs. *Amer. J. Math.*, 54(1):150–168, 1932.

DEPARTMENT OF MATHEMATICS, INDIANA UNIVERSITY

E-mail address: `pblamber@indiana.edu`

URL: <https://pages.iu.edu/~pblamber>

DEPARTMENT OF MATHEMATICS, INDIANA UNIVERSITY

E-mail address: `odonnol@indiana.edu`

URL: <http://pages.iu.edu/~odonnol/>