

Joint Power and Resource Allocation for Block-Fading Relay-Assisted Broadcast Channels

Mohammad Shaqfeh, *Member, IEEE*, Hussein Alnuweiri, *Member, IEEE*

Abstract—We provide the solution for optimizing the power and resource allocation over block-fading relay-assisted broadcast channels in order to maximize the long term average achievable rates region of the users. The problem formulation assumes regenerative (repetition coding) decode-and-forward (DF) relaying strategy, long-term average total transmitted power constraint, orthogonal multiplexing of the users messages within the channel blocks, possibility to use a direct transmission (DT) mode from the base station to the user terminal directly or a relaying (DF) transmission mode, and partial channel state information. We show that our optimization problem can be transformed into an equivalent “no-relaying” broadcast channel optimization problem with each actual user substituted by two virtual users having different channel qualities and multiplexing weights. The proposed power and resource allocation strategies are expressed in closed-form that can be applied practically in centralized relay-assisted wireless networks. Furthermore, we show by numerical examples that our scheme enlarges the achievable rates region significantly.

Index Terms—wireless networks, relaying, resource allocation, multiuser diversity, long-term-evolution (LTE)

I. INTRODUCTION

Although the relay channel was investigated by the information theory researchers long time ago ([1], [2]), the topic of cooperation/relaying schemes have recently become a very active research area within both the information theory as well as communications engineering societies. Few examples of recent works among many others are [3], [4], [5], [6], [7], [8], [9], and [10]. It is well-understood now that relaying strategies can improve the coverage of wireless networks by providing higher data rates or better transmission reliability to terminals at the edge of a wireless cell (i.e. terminals which receive low signal power from the base station).

Relaying technologies are also becoming part of the telecommunication standards [11]. Although many advanced schemes based on the cooperation of the mobile users to help each other are being studied in the literature, the first actual deployment step which will take place within the 3GPP¹ Long-Term Evolution (LTE)-Advanced (c.f. [12], [13], [14]) standard is based on fixed access points² to do the relaying and within a centralized scheme in which the e-nodeB (base

station with backhaul connection) takes the scheduling and resource allocation decisions. One major objective in 3GPP evolution is to utilize the scarce wireless system resources efficiently because achieving the high Quality-of-Service (QoS) targets through over-provisioning is uneconomical due to the relatively high cost for transmission capacity in cellular access networks [15].

Our objective here is to obtain the optimal (in information theoretic perspective) resource allocation schemes but with applying system constraints that are relevant to the LTE-Advanced standard so that it can be applied practically in the first introduction of relays to the wireless cellular systems industry. We have been able to derive the optimal power, resource allocation and scheduling policies that are provably based on closed-form formulations which are practical for implementation. Our proposed resource allocation schemes provide an integrated solution to exploit the cooperative (relaying) diversity gains [3] as well as the multiuser diversity gains [16].

Optimal dynamic resource allocation over fading channels has been investigated in the literature for non-cooperative (i.e. with no relaying) wireless systems in [17] for the single-user case, in [18] for multi-access (many-to-one) channels, and in [19] and [20] for broadcast (one-to-many) channels. Optimal resource allocation for fading relay channels has been studied in [21], [22] for single source and single destination node case. Resource allocation for broadcast-relay channels was also treated in [23] and [24], where the problem setup assumes that users terminals cooperate together (i.e. act as relays to help other users). This is a different problem setup than the problem in this paper in which we assume that fixed-relays are used to assist in the transmission without being destination nodes themselves. In [25] and [26], joint power and resource allocation over multiple access relay-assisted channels was studied for a constant channel realization scenario, where it was demonstrated that joint allocation of power and channel resources can enlarge the achievable rate region.

In this paper, we consider the broadcast relay-assisted channels under block-fading conditions (i.e. over many channel realizations). In [27], [28], and [29] relay-assisted broadcast (downlink) channels with centralized scheduling were considered with different performance metrics such as throughput-guarantees or fairness measures. In our work, we tackle the problem from an information-theoretic perspective in which we aim to maximize the achievable rate region. This is equivalent to the problem of minimizing the transmitted power to achieve requested rate demands. To the best of our knowledge, maximizing the achievable rate region of block-fading relay-

M. Shaqfeh and H. Alnuweiri are with the Department of Electrical and Computer Engineering, Texas A&M University at Qatar, C/o Qatar Foundation, PO Box 23874, Doha, Qatar. (E-mail: {Mohammad.Shaqfeh, Hussein.Alnuweiri}@qatar.tamu.edu).

This work was supported by the National Priorities Research Program from Qatar National Research Fund.

¹Third Generation Partnership Project.

²The relays will be base stations but without a wired or microwave connection to the backhaul network.

assisted broadcast channels for the case of applying half-duplex regenerative decode-and-forward (RDF) [3] relaying strategy and orthogonal multiplexing of user messages within the channel blocks has not been treated in the literature. As well-known from the information theory literature, the achievable rate region can be enlarged (i.e. improved) by using non-orthogonal (superposition-based with successive interference cancellation at the receivers) transmission strategies as well as more advanced relaying strategies³ than RDF. However, we restrict our optimization problem with systems constraints which are favorable for a practical deployment.

We formulate our optimization problem assuming partial channel-state-information (CSI). Similar to the definition adopted in [9], by partial CSI we mean that the transmitter (source node) knows the channel state amplitudes only (i.e. the channel power gain), while the receiver knows both the channel amplitude and phase. This can be usually accomplished by separate low rate feedback channels. According to LTE specifications [13], CSI is obtained by various means and forwarded to the base station, where the resource allocation decisions are done. The scheduling information are provided to the other nodes in the network using dedicated control channels. Furthermore, we apply a single long-term average total (i.e. sum) power constraint in the formulation of the optimization problem instead of using separate power constraints for every involved node (the source and relay nodes). This approach has been adopted in some works in the literature such as [9]. The main reasons for applying a single power constraint are: (i) using separate power constraints for every node is less dynamic than using a sum-power constraint for all nodes since the solution of the latter formulation involves the optimal power distribution among the nodes to maximize the required objective (maximizing the achievable rate region in our case). On the other hand, with separate power constraints, the power distribution among the nodes is fixed beforehand and, as a result, we lose one factor that can help us to maximize our objective, (ii) we believe that the sum-power constraint is relevant in practice since the relay nodes are fixed access points that are not limited in energy supply (i.e. they are not running on batteries like mobile handsets). So, we can distribute the power among the relays based on the users distribution in the cell, and hence we can involve one relay more than the others if there are more users in its vicinity. Note that if no relays are involved at all, the base station will transmit all the power anyway. In our problem formulation, we are just re-distributing some of that total power among the relays in the most efficient way, (iii) solving the optimization problem with many power constraints will be based on bisection-based methods over many dimensions similar to the solution in [25] for the multiple-access case, while using a sum power constraint will result in closed-form

³For example, full-duplex relaying strategies, which require the relay terminal to be able to receive and transmit simultaneously on the same channel, gives better throughput gains than half-duplex strategies. However, this requirement is difficult to implement in practice because of the complexity of providing electrical isolation between the transmitter and receiver circuitries. Thus, half duplex relaying strategies are favorable from practical point-of-view although they result in multiplexing loss because the same message is transmitted over two orthogonal slots.

solutions which are simpler and more practical to be applied in real systems.

Following this introduction section, we present in Section II the channel model and the optimization problem formulation as well as the applied mathematical notation. In Section III we provide the solution of the optimization problem. Despite the relative large number of optimization variables involved in the problem, we demonstrate that the problem can be solved by: (i) characterizing the maximum achievable rates using RDF links with optimal power allocation over the source and the relay, and (ii) transforming the problem into an equivalent “no-relaying” broadcast channel with each “actual” user replaced by two “virtual” users having different channel qualities and multiplexing weights. In order to understand the mathematical solution steps, the reader is advised to go through [19, Section III-B] in which the orthogonal “non-cooperative” broadcast channel was considered. We give the solution for our problem which includes the closed-form policies to select the best relay, schedule the users across the resource units, choose the optimal transmission mode and control the transmission power. We include also the case of optimizing resource allocation over each channel realization separately and use it for comparison with the optimal case. We provide numerical examples in Section IV to demonstrate the advantages of our suggested resource allocation scheme. Then, we summarize the main conclusions of our work in Section V.

II. SYSTEM MODEL AND PROBLEM FORMULATION

A. Channel Model

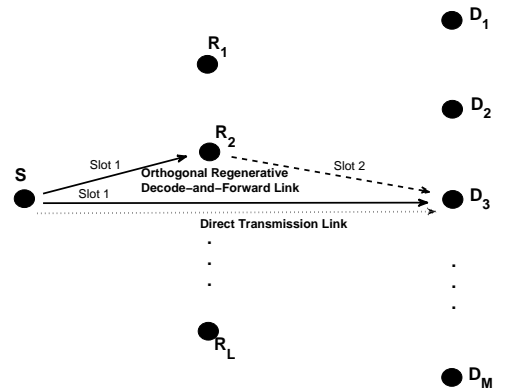

Fig. 1. System diagram of relay-assisted broadcast channels with one source node, L relay nodes and M destination nodes. The message sent to a destination node can go through half-duplex RDF link with the assistance of one of the relay nodes, or through a direct transmission link from the source node to the destination node without the assistance of the relays.

We consider the M -user relay-assisted broadcast system shown in Fig. 1. The system consists of one source node (S), M destination nodes (D), and L relay nodes (R) which

can be used to assist in the transmission from the S -node to any of the D -nodes. The R -nodes are connected to other nodes by wireless links only. Any message transmitted by the S -node is destined to only one D -node. We assume that the message transfer from the S -node to a D -node can go through two possible modes: (i) a direct transmission (DT) link without the assistance of any of the R -nodes, (ii) a half-duplex regenerative (i.e. repetition coding) decode-and-forward (DF) link in which one of the relays assists in the communication between the source and the destination. The S -node represents the base station, while the D -nodes correspond to the mobile users' terminals.

We assume a block-fading channel model in which the air-link resource grid is divided in both time and frequency domains into small blocks called resource units (RUs)⁴. The channel is assumed to be constant within one RU, but varying (fading) independently across the RUs in the air-link grid. The resource units are orthogonal to each other (non-overlapping). Furthermore, we assume that all messages are multiplexed orthogonally in all RUs. Irrespective of their transmission mode (i.e. DF or DT), one or many users can receive in the same RU (subject to optimization). However, if more than one user is receiving messages in the same resource unit, the messages of the users are multiplexed orthogonally by frequency division⁵. A DF link is divided into two sub-units occupying the same frequency band but having orthogonal time division multiplexing. Fig. 2 shows how the air-link resource grid is divided, and an example of how the users may be scheduled across the RUs. One of the possibilities is that two independent messages are sent to the same D -node in the same RU, but with different transmission modes; i.e. one message is sent through a DT link and the other one using a DF link. Several other possibilities are illustrated in Fig. 2.

Additionally, we assume that the channel realizations (blocks) are large enough (i.e. slow fading assumption) so that each codeword destined to any user can be transmitted over one channel block with close-to-capacity limits rate.

B. Problem Formulation

In this work, we provide answers to several fundamental questions⁶ concerning the resource allocation schemes to be applied in the system:

- 1) When (i.e. under what conditions) is a DT link optimal? When is a DF link optimal? When is the orthogonal multiplexing of both modes optimal?

⁴As well-known from LTE specifications, the time-frequency resource grid is divided into resource units (RU) which are allocated flexibly to user terminals [14]. A pair of adjacent resource units (0.5 ms each) is allocated to one terminal based on the scheduler decisions.

⁵As known from LTE specifications, one RU spans several OFDM subcarriers. So, in principle, we can let multiple users share the same RU orthogonally. However, according to LTE specifications, one RU can be used by one user only. So, it may appear that our problem formulation is not practical to be applied in LTE systems. However, as discussed in Section III, the solution of the optimization problem with the orthogonality constraint involves that only one D -node receives in one channel block (RU unit) using either DT or DF.

⁶Some of these questions may have been discussed in the literature for other channel models or problem setup. We are interested here in the optimal resource allocation scheme within the assumptions and channel model adopted in this paper.

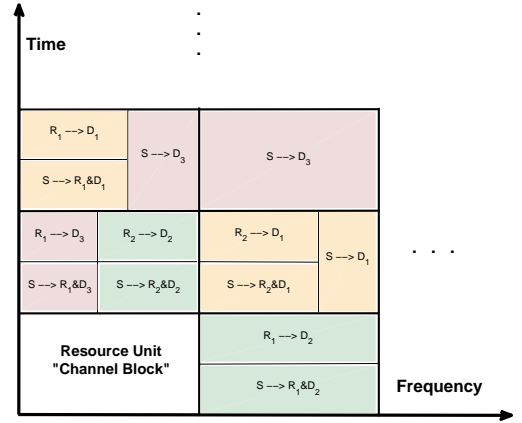

Fig. 2. Dividing the total air-link resource grid into small blocks called resource units, which are assumed to be flat faded (i.e. the bandwidth of a RU and its time duration are smaller than the coherence bandwidth and the coherence time of the fading channels). Within one RU, one or more users can receive a message from the source node. All transmissions are orthogonal to each other. Based on the channel conditions, the messages and their associated transmission modes can be scheduled flexibly to the users terminals.

- 2) How should we select the relay that is most capable of supporting the transmission to a D -node? What is the optimal policy to allocate the power for the S -node and the R -node over a DF link?
- 3) How should the scheduler process the CSI to determine the number of messages to be transmitted in a RU and their transmission modes? What is the optimal policy to allocate the power and the channel ratios for every message?

Furthermore, in a flexible system where the users can have different requested rates dependent on, for example, the supported services, the resource allocation schemes should be flexibly adjustable to operate at any of the possible operating points of the system. In this paper, we solve the resource allocation problem to operate at any pre-determined point on the achievable rates region. The achievable rates region is defined as the set of all long-term average rate vectors⁷ $\bar{\mathbf{R}} = [\bar{R}_1 \bar{R}_2 \cdots \bar{R}_M]$ achieved by the nodes D_1, D_2, \cdots, D_M such that the long-term average sum (of all nodes) power density constraint \bar{P} is not exceeded. To simplify the mathematical formulation of the problem, we assume that R and P represent spectral densities (i.e. bits/sec/Hz and Joul/sec/Hz respectively).

The optimum points within the achievable rates region are those that are located on the boundary surface. The latter can be characterized as the closure of the parametrically defined

⁷We use boldface to indicate vectors.

surface

$$\{\bar{\mathbf{R}}(\boldsymbol{\mu}) : \boldsymbol{\mu} \in \mathcal{R}_+^M, \sum_i \mu_i = 1\} \quad (1)$$

where for every weighting-factors vector $\boldsymbol{\mu}$, the rate vector $\bar{\mathbf{R}}(\boldsymbol{\mu})$ can be obtained by solving the optimization problem:

$$\max \sum_{i=1}^M \mu_i \bar{R}_i, \quad \text{subject to } \frac{1}{K} \sum_{k=1}^K P[k] \leq \bar{P} \quad (2)$$

where $K \rightarrow \infty$ is the total number of channel blocks, and M is the number of active users. \bar{R}_i is the long-term average (i.e. averaged over all channel blocks) rate of user i . The relationship between R and P will be obtained in Section III. For simplicity, we use a single index k to refer to a RU although the resource grid is divided in both time and frequency domains. We assume without-loss-of-generality that all channel blocks (RUs) have identical frequency bandwidth and time duration. $P_i[k]$ and $P[k]$ are respectively the sum (of the source node and the relay node) power density (Joul/sec/Hz) used specifically to transmit to node D_i , and the sum power density (Joul/sec/Hz) transmitted (including all receiving nodes) during channel block k .

All power and resource allocation polices proposed in this paper are presented as functions of the weighting factors vector because it defines the specific operating point of the system. The selection of $\boldsymbol{\mu}$ to meet the constraints of the provided services (applications) is a different topic that is not discussed in this work⁸. Few examples of the many possible approaches suggested in the literature to select the specific operating point of the system are (i) the fairness-based approach, such as the proportional fairness scheduler [32] and the flexible resource-sharing constraints scheduler [33], (ii) the utility-maximization-based approach [34], and (iii) the Quality-of-Service (QoS) constraints based approach [35][36].

C. Mathematical Notation

The notation $R_i[k]$ means the achievable rate (bits/sec/Hz) at node D_i during one RU, which has index k . In our mathematical notations, we use superscripts to differentiate between DT and DF links. Similarly, we use subscripts to indicate the nodes involved. We denote the relay node associated with destination node D_i as $R_{l(i)}$. Furthermore, we denote the channel access ratios (i.e. bandwidth ratio) of user D_i within channel block k as $\tau_i^{DT}[k]$ for the DT link, and $\tau_i^{DF}[k]$ for the DF link. It should be clear that $\sum_{i=1}^M (\tau_i^{DT}[k] + \tau_i^{DF}[k]) = 1$. The channel gain between two nodes is represented by h . For example, h_{sd_i} is the channel quality between the source node and the destination node (D_i). Fig. 3 shows an example of one RU (with index k) with a DF link to one node D_i as well as a DT link to another node D_j multiplexed orthogonally in the frequency domain. The relations between the transmitted signals ($x_i^{DF}[k]$, $x_j^{DT}[k]$) and the signals ($y[k]$) received by

the destination and relay node associated with node D_i in each of the orthogonal sub-channels within the resource unit k are shown in Fig. 3. Here, $z_{d_j}^{DT}[k]$ and $z_{r_{l(i)}}^{DF_1}[k]$ represent the additive zero-mean white circular complex Gaussian noise with variance σ^2 at D_j and $R_{l(i)}$ respectively.

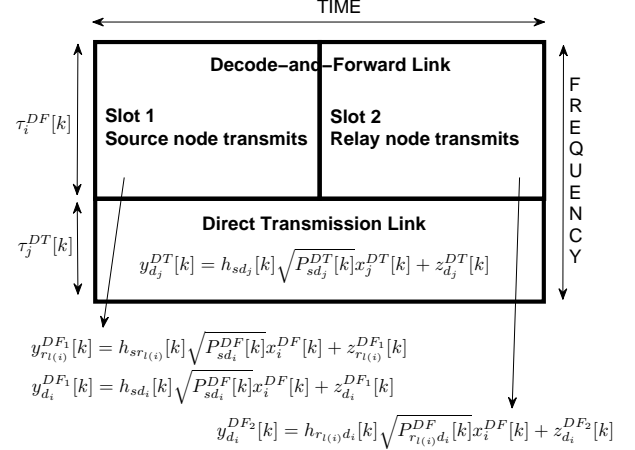

Fig. 3. An example of the orthogonal division of one resource unit k to transmit to users D_i (using DF mode with assistance of node $R_{l(i)}$) and D_j (using DT mode). The received signals at the associated nodes are shown as functions of the transmitted signals.

We use the notation $\gamma = \frac{|h|^2}{N_o}$ for the effective power gain of a given channel, where N_o is the noise power spectral density. We assume that the fading processes of the channel gains (γ_{sd_i} , $\gamma_{sr_{l(i)}}$, $\gamma_{r_{l(i)}d_i}$) are independent of each other, stationary and have continuous probability density functions, $f_\gamma(x)$. In the numerical examples throughout the paper, we assume the fading processes have Rayleigh⁹ or Rice¹⁰ distributions [37].

III. SOLUTION STRUCTURE

Looking back at our optimization problem (2), the achievable rate $R_i[k]$ is the sum of the rates achieved by the DT and DF links multiplied by their relative channel access ratios:

$$\tau_i[k] R_i[k] = \tau_i^{DF}[k] R_i^{DF}[k] + \tau_i^{DT}[k] R_i^{DT}[k] \quad (3)$$

The maximum possible achievable rate (bits/sec/Hz) of user i through DT link is given by:

$$R_i^{DT}[k] = \log(1 + \gamma_{sd_i}[k] P_{sd_i}^{DT}[k]) \quad (4)$$

for additive white Gaussian receiver noise, where (4) is the Shannon capacity for the AWGN channel. With adaptive modulation and coding, a rate close to capacity can be achieved (e.g. [38]). In practice, wireless systems support a set of

⁹ $f_\gamma^{\text{Rayleigh}}(x) = \frac{1}{\bar{\gamma}} \exp\left(-\frac{x}{\bar{\gamma}}\right)$, $x > 0$, $\bar{\gamma}$ is the average effective power gain of the channel.

¹⁰ $f_\gamma^{\text{Rice}}(x) = \frac{\kappa+1}{\bar{\gamma}} \exp\left(-\kappa - \frac{\kappa+1}{\bar{\gamma}}x\right) I_0\left(2\sqrt{\frac{\kappa(\kappa+1)x}{\bar{\gamma}}}\right)$, $x > 0$, $\bar{\gamma}$ is the average effective power gain of the channel, and κ is the ratio of the power received through the line-of-sight path to the power received through the non-light-of-sight path.

⁸As discussed in [30] and [31], there is no contradiction between the two objectives of (i) efficient resource allocation by designing resource allocation schemes leading to operating at the points on the boundary of the achievable rates region, and (ii) achieving fairness among the users as well as maintaining the QoS requirements, which can be done by controlling the operating point of the system based on proper selection of $\boldsymbol{\mu}$.

discrete rate values rather than a continuous range. However, we use the idealization (4) to relate “power” and “rate”; the relative performances¹¹ will carry over into practice.

The achievable rate by regenerative decode-and-forward relaying is known from the literature (e.g. [3]):

$$R_i^{DF}[k] = \min \left\{ \begin{array}{l} \frac{1}{2} \log \left(1 + \gamma_{sr_{l(i)}}[k] P_{sd_i}^{DF}[k] \right), \\ \frac{1}{2} \log \left(1 + \gamma_{sd_i}[k] P_{sd_i}^{DF}[k] + \gamma_{r_{l(i)}d_i}[k] P_{r_{l(i)}d_i}^{DF}[k] \right) \end{array} \right\} \quad (5)$$

The first term in (5) is the achievable rate by the relay node in the first time slot. Since, in RDF, the relay has to decode the signal in order to retransmit it in the second time slot, the achievable rate by the destination node is upper bounded by the “decodable” rate limit at the relay. The $1/2$ factor which is multiplying the log function is due to the fact that the information is conveyed to the relay in half the total time assigned for transmitting the signal to the D -node. The second term in (5) is the maximum achievable rate by the D -node using Maximal-Ratio-Combining (MRC), e.g. [16], of the signal received from the source in the first slot, and the signal received from the relay in the second time slot.

In the sequel, we assume a single relay selection per-user and per-resource unit in RDF transmission mode. This is appropriate from a practical point of view especially that we assume partial CSI (no phase information) available at the transmitters. In Appendix A we extend the solution to the case of multiple-relay selection per-user which requires full CSI (i.e. including phase information) in order to enable coherent (in phase) transmission of multiple relays.

The set of optimization variables for the problem (2) includes the power allocated to each node as well as the corresponding channel access ratios for every transmission mode in every channel block k . We need first to characterize the achievable rate by RDF links in order to solve (2).

A. Achievable Rate by Regenerative Decode and Forward

Our objective here is to maximize $R_i^{DF}[k]$ (5) with respect to the sum power allocated to the DF link:

$$P_i^{DF}[k] = \frac{1}{2} P_{sd_i}^{DF}[k] + \frac{1}{2} P_{r_{l(i)}d_i}^{DF}[k] \quad (6)$$

The $1/2$ factors in (6) are used because we present P as (Joul/sec/Hz), and the source and relay nodes are transmitting in half the total time. For simplicity, we will drop the user index i as well as the channel block index k in our mathematical formulations in this sub-section.

We first define when the DF link can be useful. By the notion “useful DF link” we mean that it could (for some power range) support higher data rate than a DT link given that both transmission modes are allocated the same total power.

Proposition 1: If γ_{sr} or γ_{rd} is less than γ_{sd} , then transmitting using a DT link supports higher data rates than using a

DF link, which means that the DF link is NOT useful in this case.

Proof: If $\gamma_{sr} < \gamma_{sd}$, then the relay node can decode at rates less than the rates achievable by the DT link. Similarly, if $\gamma_{rd} < \gamma_{sd}$, then allocating the power in the second slot to the source node to retransmit the codeword is better than allocating the power to the relay node. ■

The next step is to solve the problem:

$$\max_{P_s^{DF}, P_r^{DF}} R^{DF} = \min \left\{ \begin{array}{l} \frac{1}{2} \log \left(1 + \gamma_{sr} P_s^{DF} \right), \\ \frac{1}{2} \log \left(1 + \gamma_{sd} P_s^{DF} + \gamma_{rd} P_r^{DF} \right) \end{array} \right\} \quad (7a)$$

subject to

$$\gamma_{sr} > \gamma_{sd}, \gamma_{rd} > \gamma_{sd}, \left(\frac{1}{2} P_s^{DF} + \frac{1}{2} P_r^{DF} \right) = P^{DF}. \quad (7b)$$

Proposition 2: The optimal allocation of the source power and the relay power over a useful DF link can be obtained by making the two terms in (7a) equal each other.

Proof: The first term in (7a) (i.e. $\frac{1}{2} \log \left(1 + \gamma_{sr} P_s^{DF} \right)$) is a monotonically increasing function of P_s^{DF} . On the other hand, the second term in (7a) (i.e. $\frac{1}{2} \log \left(1 + \gamma_{sd} P_s^{DF} + \gamma_{rd} P_r^{DF} \right)$) is a monotonically decreasing function of P_s^{DF} because $\gamma_{rd} > \gamma_{sd}$, and the sum of P_s^{DF} and P_r^{DF} is constant (equals $2P^{DF}$). Thus, to maximize the minimum of the two terms in (7a), we should make them equal. ■

Hence, the power allocation over a useful DF link should be as follows:

$$P_s^{DF} = \frac{2P^{DF}}{1 + \frac{\gamma_{sr}-1}{\gamma_{rd}}}, P_r^{DF} = 2P^{DF} - P_s^{DF} \quad (8)$$

where γ'_{sr} and γ'_{rd} in (8) are defined as:

$$\gamma'_{sr} \doteq \frac{\gamma_{sr}}{\gamma_{sd}}, \gamma'_{rd} \doteq \frac{\gamma_{rd}}{\gamma_{sd}} \quad (9)$$

Furthermore, the achievable rate over a useful DF link (i.e. $\gamma'_{sr} > 1$ and $\gamma'_{rd} > 1$) is:

$$R^{DF}(P^{DF}) = \frac{1}{2} \log \left(1 + 2\alpha \gamma_{sd} P^{DF} \right) \quad (10)$$

where

$$\alpha = \frac{\gamma'_{sr} \gamma'_{rd}}{\gamma'_{sr} + \gamma'_{rd} - 1} \quad (11)$$

The parameter α is actually the power gain that the RDF link is capable of providing. It should be clear from (11) that if a relay is useful, then $\alpha > 1$. The result in (10) is interesting because it fits with the expectation that a half-duplex relaying strategy provides a power gain (i.e. beamforming gain) at the cost of a loss (by half) in the degrees-of-freedom¹² (i.e. multiplexing gain). The beamforming gain is obtained because the receiver decodes the signal at higher Signal-to-noise-ratio (SNR) although the same total power is used for the transmission. The loss in the multiplexing gain is a result of transmitting the message over two time slots. Thus, RDF, and all half-duplex relaying strategies in general, can be useful

¹¹The “absolute” performance of a combination of specific modulation and coding schemes can often be approximated by (4) as well. An “acceptable” residual bit or frame error rate will often be achieved by a practical scheme with some (fairly constant) power-offset against the theoretical “zero-error” curve given by (4).

¹²Readers who are not familiar with the notions of degrees-of-freedom, bandwidth-limited and power-limited regions of the AWGN channel capacity formula can refer to [16, Chapter 5].

for terminals which are operating in the power limited region of the channel capacity where the achievable rate (bits/sec) has almost a linear relation with SNR. This means that RDF can support higher rates than a DT link only for users with low SNR (i.e. close or at the cell edge). On the other hand, terminals operating in the bandwidth-limited region of the channel capacity (i.e. at high SNR) will be affected by the loss in degrees-of-freedom of RDF, and hence a DT link can support higher data rate in this case. Actually, it can be shown that other half-duplex relaying strategies such as amplify-and-forward (AF) have achievable rate performance similar to (10), but with more complicated formulas to express the power gain α in terms of the channel qualities between the source, relay and destination nodes. RDF has the nice property that α is a function of the channel qualities only and independent of the total power allocated to the link. This is not the case with other relaying strategies such as AF.

Now, we can define the criteria to select the unique relay that should be selected in the RDF link. It is the one that provides the best power gain in order to maximize the total achieved rate at the destination node given the total power allocated to the DF link. The best relay to be associated with node D_i is $R_{l(i)}$ where $l(i)$ is defined as:

$$l(i) = \arg \max_j \alpha_{r_j d_i} \quad : \quad \gamma_{sr_j} > 1 \text{ and } \gamma_{r_j d_i} > 1 \quad (12)$$

In the remaining part of this paper, we will use (10) to characterize the performance of RDF links. We assume that proper relay selection is used (12), and based on the allocated power to the RDF link (P^{DF}), the source and relay power should be allocated according to (8). For simplicity, we will drop the index of the relay and just use $\alpha_i[k]$ to indicate the best power gain for the RDF link. If none of the relays is useful, we will use the DT link only for transmission. Otherwise, an orthogonal multiplexing between the DT link and the DF link should be used (subject to optimization).

B. Optimal Resource Allocation – Broadcast Channel with $2M$ Virtual Users

The results in Section III-A leads to a very interesting consequence that we can transform our problem into a broadcast (with no relays) channel with each actual user replaced by two virtual users having different channel qualities and multiplexing weights, corresponding to the two different transmission modes (i.e. DT or DF) of the actual user. The only difference between our problem and the original broadcast channel is that we will have two classes of users in terms of the relation between the achievable rate and the allocated power. However, this does not change the structure of the problem solution and the interesting closed-form solution of it [19]. The achievable rates multiplied by the corresponding multiplexing factor of the $2M$ virtual users¹³ will have the form

$$f_j(P_j) = \omega_j \log(1 + \eta_j P_j) \quad (13)$$

where the virtual user j that is related to one of the transmission modes of the actual user i is characterized by:

$$\omega_j = \begin{cases} \mu_i & \text{if DT} \\ \frac{\mu_i}{2} & \text{if DF} \end{cases}, \quad \eta_j = \begin{cases} \gamma_{sd_i} & \text{if DT} \\ 2\gamma_{sd_i}\alpha_i & \text{if DF} \end{cases} \quad (14)$$

where μ_i is defined in the problem formulation (2), and α can be obtained using (11) and (12). As well known [19], if the cumulative-density-function (CDF) of the fading process is a continuous function (this is true in reality such as in Rayleigh and Rice fading conditions), then *the optimal resource allocation policy is unique and at most a single user only is scheduled in each fading state (i.e. channel block). Furthermore, the power allocated to the scheduled user follows a water-filling approach.*

Thus, every RU should be allocated to only one user with only one transmission mode (i.e. either DF or DT and not both). The index m of the only virtual user that should be scheduled in channel block k (i.e. $\tau_l[k] = 1$ if $l = m$ and $\tau_l[k] = 0$ if $l \neq m$, $l = 1, 2, \dots, 2M$) is:

$$m = \arg \max_j (f_j(P_j[k]) - \lambda_G P_j[k]) \quad (15)$$

where f_j is defined in (13), and λ_G is the ‘‘power price’’¹⁴ which should be controlled to maintain the average power constraint \bar{P} . $P_j[k]$ in (15) is dependent on the transmission mode of the corresponding actual user i related to the virtual user j :

$$P_j[k] = \left[\frac{\omega_j}{\lambda_G} - \frac{1}{\eta_j[k]} \right]^+ \quad (16)$$

where $(x^+ = \max(x, 0))$. Once we obtain m according to (15), we can determine the actual user that should be scheduled and the optimal transmission mode.

Expressions (12), (15), (16) and (8) provide valuable closed-form policies to select the best relay, schedule the users across the RUs, choose the optimal transmission mode and control the transmission power.

C. Optimal Resource Allocation with Constant Power per Channel Block

If the resource allocation is optimized for each channel block independently from other channel blocks and irrespective of the scheduled users or selected transmission mode in each channel block, the corresponding optimization problem is:

$$\max_{\{\tau_j[k], P_j[k], j=1, \dots, 2M\}} \sum_{j=1}^{2M} \tau_j[k] f_j(P_j[k]), \quad (17a)$$

subject to

$$\sum_{j=1}^{2M} \tau_j[k] P_j[k] \leq P[k]. \quad (17b)$$

where M is the number of active users, and f_j is the achievable rate multiplied by the weighting index as defined in (13). Note

¹³If some users do not have useful relay links, then the total number of virtual users will be less than $2M$.

¹⁴The optimal value of λ_G in order to achieve a desired average power level is dependent on the channel statistics. One option is to control λ_G in real-time based on actual channel measurements [35].

that since we assumed in our problem definition in Section II-B that R and P represent spectral densities (i.e. their units are bits/sec/Hz and Joul/sec/Hz respectively), the actual short-term average rate and power (averaged within one channel block k) should be obtained by multiplying with the corresponding channel access ratio (within channel block k) $\tau_j[k]$ for each virtual user j .

The solution of (17) can be obtained by applying the concept of virtual users over a no-relaying broadcast channel that is discussed in Section III-B. The solution of the problem [19] is that either one or two virtual users (could be related to the same actual user or to two different actual users) are scheduled within the channel block k .

Depending on the value of $P[k]$, the solution of the general case of problem (17) is either one or two elements in \mathbf{P} and τ are non-zero. The domain $[0, \infty)$ of the functions f_j , $j = 1, \dots, 2M$ will be divided into adjacent intervals which are alternating between (i) intervals in which the solution of the optimization problem is that the optimization variables of only one function (i.e. virtual user) should be non-zero, given that $P[k]$ belongs to the corresponding interval, and (ii) intervals in which the optimization variables of two functions are non-zero, with the values of the P variables of these two functions identical to the values of the two end-points of the corresponding interval, and the τ variables for these two functions dependent on the relative location of $P[k]$ with respect to the interval end-points. An algorithm was provided in [19, pp. 1089, first column] to obtain the solution.

Fig. 4 provides an illustration of the solution to problem (17). The example presented in Fig. 4 is for three virtual users (two actual users with one of them having no useful DF link).

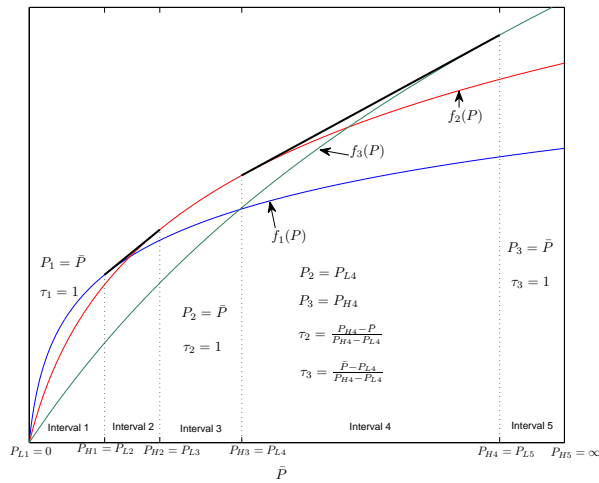

Fig. 4. An illustrative example of problem (17) with three virtual users. The dependence of the solution on the specific interval, to which \bar{P} belongs, is illustrated.

In addition to the optimal solution, we suggest also a sub-optimal solution which is simple and close to optimality. The near-optimal solution is:

$$\tau_m = 1, P_m = P[k], \text{ where } m = \arg \max_i f_i(P[k]) \quad (18)$$

This near-optimal solution is identical to the optimal solution when only one virtual user is optimizing the problem. However, if two virtual users are involved in the optimal solution, the sub-optimal solution still gives near-optimal performance because the difference between the tangent line between the two functions, which optimize the problem, and the maximum of the two functions is usually very small.

IV. NUMERICAL EXAMPLES

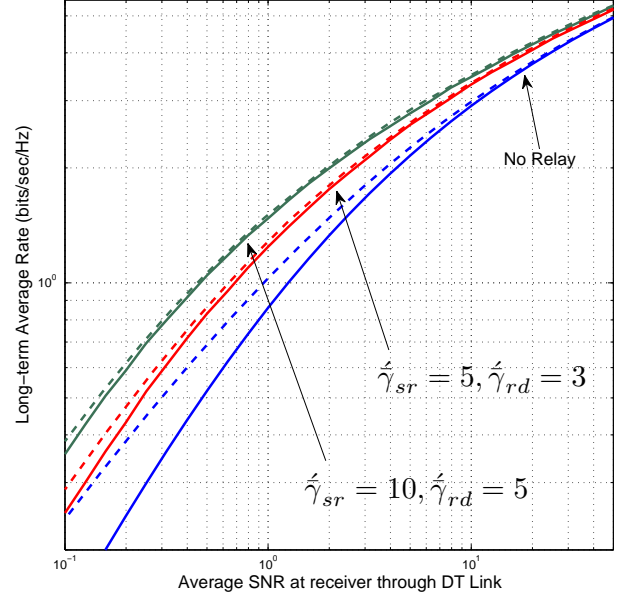

Fig. 5. Comparisons of the achievable rates using (i) direct transmission only, (ii) orthogonal multiplexing of RDF and DT with optimal power allocation. The solid lines correspond to the case of constant total power per channel realization, and the dashed lines correspond to the case of optimal power allocation over all channel realizations.

We provide in Fig. 5 numerical comparisons of the maximum achievable rates in a single-user case with and without applying the optimal power allocation strategy studied in this paper. The simulation results were obtained for the scenario when the power gain over the source-destination link is Rayleigh faded, while the power gain over the source-relay and relay-destination is Rician faded with better average channel qualities than over the direct link. Such scenario is relevant when there is no line-of-sight (LOS) path between the source and the destination nodes, while the relay node is in a position where it has LOS paths to both of them. The simulation results in Fig. 5 were done for two cases: (i) $\frac{\tilde{\gamma}_{sr}}{\tilde{\gamma}_{sd}} = 5$, $\frac{\tilde{\gamma}_{rd}}{\tilde{\gamma}_{sd}} = 3$, and (ii) $\frac{\tilde{\gamma}_{sr}}{\tilde{\gamma}_{sd}} = 10$, $\frac{\tilde{\gamma}_{rd}}{\tilde{\gamma}_{sd}} = 5$. In the simulations, the used values for the ratios between the power of the LOS path over the non LOS paths in the Rician faded channels are: $\kappa_{sr} = 10$ and $\kappa_{rd} = 5$.

Fig. 5 shows that potential gains can be obtained with the assistance of the relay. The gain in the achievable rate is higher at lower SNR, but still useful at mid to high SNR. Furthermore, we observe that using optimal power allocation

over all channel realizations has a small gain over constant power allocation per channel block, especially at higher SNR.

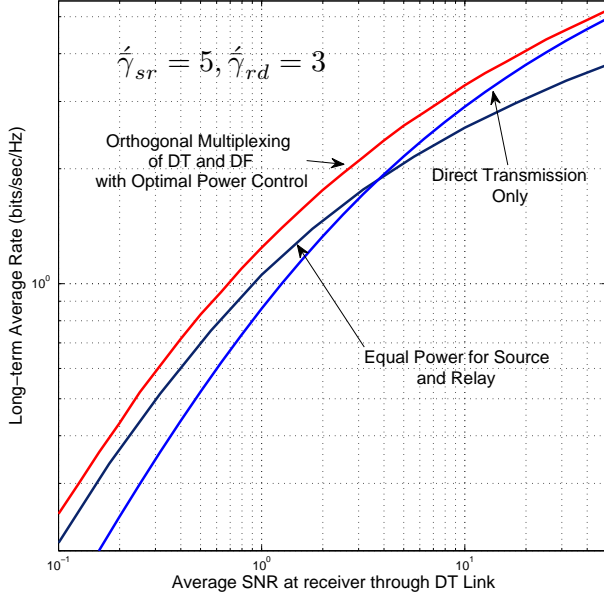

Fig. 6. Comparisons of the maximum achievable rates with relay assistance for two cases: (i) optimal power allocation, (ii) equal power allocation for the source and the relay node.

Another important observation is that with equal power allocation between the source and the relay nodes, which is shown in Fig. 6, there is a significant degradation from the achievable rates with the assistance of the relay. Furthermore, it is worse than just using direct transmission when the SNR is mid to high range. This demonstrates the advantage of the proposed power allocation strategy because it switches between DF and DT based on the channel conditions, and thus it is always better than just DT over all SNR regions.

The results in Fig. 5 and Fig. 6 were obtained assuming large number of channel blocks (realizations) in order to obtain good estimate of the average performance of the system. Fig. 7 shows the ratio of RUs – with respect to the total number of RUs used in the simulation – which have a relay link, a direct transmission link, or none for the case of $(\frac{\bar{\gamma}_{sr}}{\bar{\gamma}_{sd}} = 5, \frac{\bar{\gamma}_{rd}}{\bar{\gamma}_{sd}} = 3)$ in Fig. 5. The results in Fig. 7 include the global power control case as well as the constant power per channel block case. It is demonstrated that the DF link is more used at low SNR and decreases gradually as SNR improves, while at high SNR, the DT link is more capable of providing higher throughput to the D-node. The “no transmission” case appears when the channel condition is so bad that the optimal power control strategy is not to transmit during such deep fading conditions. It is obvious that such case appears more frequently at low SNR.

Fig. 8 displays numerical comparisons of the achievable rates region in a two-user case with and without the assistance of a relay for the two cases of optimal power allocation over all channel blocks, and constant power per channel

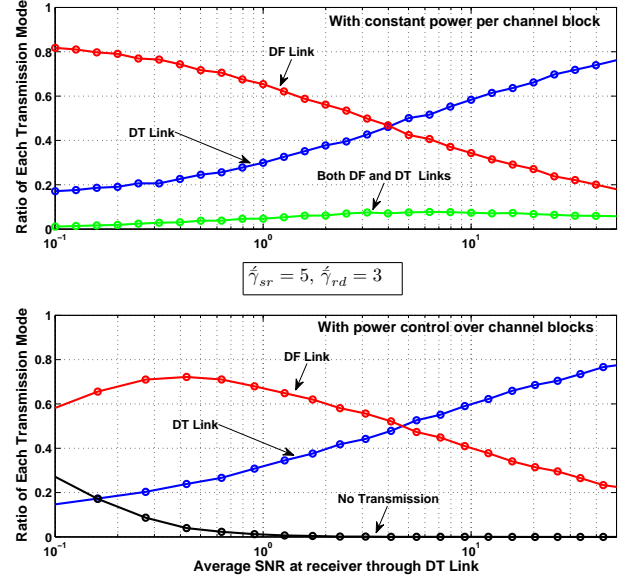

Fig. 7. Ratio of each transmission mode for the case of $(\frac{\bar{\gamma}_{sr}}{\bar{\gamma}_{sd}} = 5, \frac{\bar{\gamma}_{rd}}{\bar{\gamma}_{sd}} = 3)$ in Fig. 5.

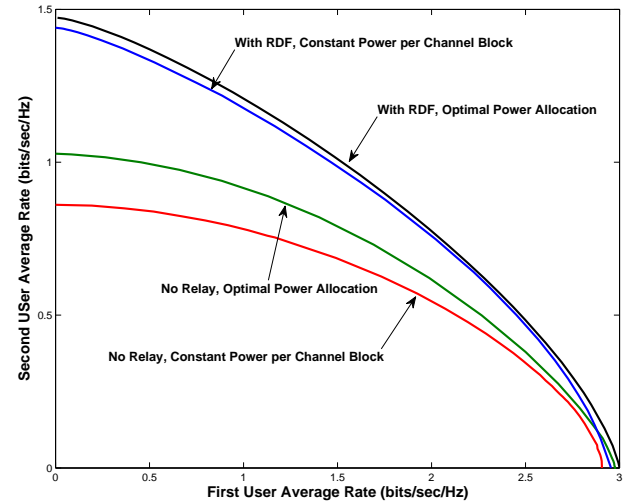

Fig. 8. Comparisons of the achievable rates in a two-user case with and without the assistance of a relay, and with and without power control over the channel blocks. The links parameters are: $\bar{\gamma}_{sr} = 10$ (Rician faded with $\kappa_{sr} = 10$), $\bar{\gamma}_{sd1} = 10$ (Rayleigh faded), $\bar{\gamma}_{rd1} = 2$ (Rician faded with $\kappa_{rd1} = 2$), $\bar{\gamma}_{sd2} = 1$ (Rayleigh faded), $\bar{\gamma}_{rd2} = 5$ (Rician faded with $\kappa_{rd2} = 5$).

block. The simulation results were obtained using the channel quality parameters shown in the Figure caption. The results in Fig. 8 demonstrates that the RDF strategy improves the performance of the system, especially for users who have bad connection with the base station. Furthermore, we observe that using optimal power allocation over all channel realizations is advantageous, especially at low SNR. However, using constant power allocation per channel block has good performance at

higher SNR.

V. CONCLUSION

We have addressed the problem of optimal resource allocation over block-fading relay-assisted broadcast channels under practical system constraints including using orthogonal multiplexing of transmitted messages, and regenerative decode-and-forward relaying. We have formulated the optimization problem using a sum power constraint, which is a valid assumption in fixed-relays scenarios with no power limitations, and we have shown that this is sensible in order to achieve the maximum possible performance as well as to transform the problem into an equivalent “no-relaying” broadcast channel optimization which has simple closed-form solution that is practical to be applied in real-time systems. The optimal resource allocation strategy is to schedule only one user within one channel block (i.e. resource unit) and to transmit using either a direct transmission mode without the assistance of the relays or through a relaying link. The relay selection is based on the maximum power gain that can be achieved via relaying. The power allocated for each transmission follows a water-filling approach, and in case of a relaying link, a formula is derived to determine the power allocated to the source and the relay respectively. If constant power is allocated per channel block, the optimal resource allocation scheme is to schedule not more than two users within one channel block. Simulation results demonstrate that our proposed resource allocation scheme provides considerable throughput gains especially for users receiving low power from the base station.

APPENDIX A

MULTIPLE RELAY SELECTION WITH COHERENT TRANSMISSION

We extend the results presented in Section III into the case when multiple relays can be involved in the RDF transmission mode within the same resource unit (RU). In this case, all involved relays listen to the signal transmitted by the source in the first time slot, and then decode the signal and retransmit it coherently to the destination node in the second time slot such that the transmitted signals by the relays add “in-phase” at the receiver in order to maximize the received power at the destination D -node in the second time slot. This necessitates that in addition to the channel “power gain” information, the channels’ “phase” information should be known as well at the transmitters.

The multiple relay selection case can be viewed as if the relay nodes represent antennas of one “virtual” relay that has multiple distributed antennas. Thus, the relay-destination link in this case is a multiple input single output (MISO) channel. Furthermore, we can allow the source node as well to transmit in the second slot as one of the “virtual” antennas of the “virtual” multiple-antenna relay. The capacity and optimal resource allocation over MISO channel is well known in the literature (e.g. [16]). The maximum achievable effective power gain $\gamma_{r\Omega_i[k]d_i}^{DF_MISO}[k]$ of the MISO channel to destination node

i in channel block k is the sum of the effective power gains of the individual links from every antenna to the D -node:

$$\gamma_{r\Omega_i[k]d_i}^{DF_MISO}[k] = \gamma_{sd_i}[k] + \sum_{j \in \Omega_i[k]} \gamma_{r_j d_i}[k] \quad (19)$$

where $\Omega_i[k]$ is the set of indices of involved relays in the transmission to D_i in channel block k .

The maximum achievable effective power gain (19) can be achieved by in-phase transmission of the distributed antennas and by adjusting the power transmitted over every antenna j to be directly proportional to its associated effective power gain $\gamma_{r_j d}$. Thus, the power (spectral density) allocated to the relays follows:

$$P_{r_j d_i}^{DF_MISO}[k] = \frac{\gamma_{r_j d_i}[k]}{\gamma_{r\Omega_i[k]d_i}^{DF_MISO}[k]} P_{r\Omega_i[k]d_i}^{DF_MISO}[k], \quad : j \in \Omega_i[k] \quad (20)$$

where $P_{r\Omega_i[k]d_i}^{DF_MISO}[k]$ is the sum (of all antennas) power (spectral density) allocated to the second time slot of the RDF link, and $\gamma_{r\Omega_i[k]d_i}^{DF_MISO}[k]$ is obtained in (19). Similarly, the power allocated to the source node in the second time slot of RDF link is $P_{sd_i}^{DF_MISO}[k] = \frac{\gamma_{sd_i}[k]}{\gamma_{r\Omega_i[k]d_i}^{DF_MISO}[k]} P_{r\Omega_i[k]d_i}^{DF_MISO}[k]$.

All relays of the MISO RDF link should be able to decode the transmitted signal by the source in the first time slot. Thus, the achievable rate region of the RDF MISO link is:

$$R_i^{DF_MISO}[k] = \min \left\{ \begin{array}{l} \frac{1}{2} \log \left(1 + \gamma_{sr\Omega_i[k]min}^{DF_MISO}[k] P_{sd_i}^{DF_MISO}[k] \right), \\ \frac{1}{2} \log \left(1 + \gamma_{sd_i}[k] P_{sd_i}^{DF_MISO}[k] + \right. \\ \left. \gamma_{r\Omega_i[k]d_i}^{DF_MISO}[k] P_{r\Omega_i[k]d_i}^{DF_MISO}[k] \right) \end{array} \right. \quad (21)$$

where $\gamma_{sr\Omega_i[k]min}^{DF_MISO}[k]$ is the minimum effective power gain of the source-relay channels (among the involved relays in the MISO relay link). Since all relays should decode the information in the first time slot, the achievable rate in the first time slot is bounded by the worst channel condition among all relays. Our objective is to find the optimal power allocation in the first and second time slots of the RDF links, and additionally to select the relays to be involved in the distributed MISO relay link. We first observe the following facts:

- All relays that have $\gamma_{sr} < \gamma_{sd}$ should not be involved in the MISO RDF link in order for the RDF link to support higher achievable rates than in the case of direct transmission (DT). This fact can be easily proven similar to *Proposition 1* in Section III-A.
- *Proposition 2* in Section III-A is also valid in the case of multiple relays selection. This means that, for a given set (Ω_i) of selected relays for the MISO RDF link, the power allocated to the first time slot ($P_{sd_i}^{DF_MISO}$) and for the second time slot ($P_{r\Omega_i[k]d_i}^{DF_MISO}$) respectively follow (8) and (9) with the replacement of γ_{sr} and γ_{rd} by $\gamma_{sr\Omega_i min}^{DF_MISO}$ and $\gamma_{r\Omega_i[k]d_i}^{DF_MISO}$ respectively. Similarly, the achievable rate can be obtained using (10) and (11).

The power gain α that the MISO RDF link can support can

be obtained, similar to (11), by:

$$\alpha_i^{DF_MISO} = \frac{\frac{\gamma_{sr\Omega_i}^{DF_MISO}}{\gamma_{sd_i}} \frac{\gamma_{r\Omega_i d_i}^{DF_MISO}}{\gamma_{sd_i}}}{\frac{\gamma_{sr\Omega_i}^{DF_MISO}}{\gamma_{sd_i}} + \frac{\gamma_{r\Omega_i d_i}^{DF_MISO}}{\gamma_{sd_i}} - 1} \quad (22)$$

We aim to obtain the set of relays that maximize (22). It is obvious that α increases (or decreases) by increasing (or decreasing) $\gamma_{sr\Omega_i}^{DF_MISO}$ or $\gamma_{r\Omega_i d_i}^{DF_MISO}$. We can increase $\gamma_{sr\Omega_i}^{DF_MISO}$ by removing the relay with worst channel quality with the source. However, by removing this relay from the set of relays, we decrease $\gamma_{r\Omega_i d_i}^{DF_MISO}$ which is a sum of all relay-destination channels gains. Thus, we can adopt the following procedure to find the set of relays that produce the highest possible power gain (22):

- 1) Start with the set of all relays that satisfy the condition $\gamma_{sr} > \gamma_{sd}$, and compute the achievable power gain (22).
- 2) Modify the set of relays by removing the relay that has the least γ_{sr} , and re-compute the power gain.
- 3) Repeat step 2 until you get a set of one relay only.
- 4) Compare the power gains of the examined sets of relays' selection and choose the one that support the highest power gain.

Note that the results of Section III-B and Section III-C are also valid for the case of MISO RDF.

REFERENCES

- [1] E. C. Van Der Meulen, "Three-terminal communication channels," *Advances in Applied Probability*, vol. 3, pp. 120–154, 1971.
- [2] T. Cover and A. El Gamal, "Capacity theorems for the relay channel," *IEEE Transactions on Information Theory*, vol. 25, no. 5, pp. 572–584, Sept. 1979.
- [3] J. Nicholas Laneman, D. Tse, and G. Wornell, "Cooperative diversity in wireless networks: Efficient protocols and outage behavior," *IEEE Transactions on Information Theory*, vol. 50, no. 12, pp. 3062–3080, Dec. 2004.
- [4] L. Lai, K. Liu, and H. El Gamal, "The three node wireless network: Achievable rates and cooperation strategies," *IEEE Transactions on Information Theory*, vol. 52, no. 3, pp. 805–828, Mar. 2006.
- [5] G. Kramer, M. Gastpar, and P. Gupta, "Cooperative strategies and capacity theorems for relay networks," *IEEE Transactions on Information Theory*, vol. 51, no. 9, pp. 3037–3063, Sept. 2005.
- [6] A. El Gamal, M. Mohseni, and S. Zahedi, "Bounds on capacity and minimum energy-per-bit for AWGN relay channels," *IEEE Transactions on Information Theory*, vol. 52, no. 4, pp. 1545–1561, Apr. 2006.
- [7] A. Host-Madsen and J. Zhang, "Capacity bounds and power allocation for wireless relay channels," *IEEE Transactions on Information Theory*, vol. 51, no. 6, pp. 2020–2040, June 2005.
- [8] A. Reznik, S. R. Kulkarni, and S. Verdú, "Degraded Gaussian multirelay channel: Capacity and optimal power allocation," *IEEE Transactions on Information Theory*, vol. 50, no. 12, pp. 3037–3046, Dec. 2004.
- [9] D. Gunduz and E. Erkip, "Opportunistic cooperation by dynamic resource allocation," *IEEE Transactions on Wireless Communications*, vol. 6, no. 4, pp. 1446–1454, Apr. 2007.
- [10] A. Stefanov and E. Erkip, "Cooperative coding for wireless networks," *IEEE Transactions on Communications*, vol. 52, no. 9, pp. 1470–1476, Sept. 2004.
- [11] Y. Yang, H. Hu, J. Xu, and G. Mao, "Relay technologies for WiMAX and LTE-Advanced mobile systems," *IEEE Communications Magazine*, vol. 47, no. 10, pp. 100–105, Oct. 2009.
- [12] S. Sesia, I. Toufik, and M. Baker, *LTE - The UMTS Long Term Evolution: From Theory to Practice*, John Wiley & Sons, Ltd., 2009.
- [13] E. Dahlman, S. Parkvall, J. Sköld, and P. Beming, *3G Evolution: HSPA and LTE for Mobile Broadband*, Academic Press, Elsevier, second edition, 2008.
- [14] H. Ekstrom, A. Furuskär, J. Karlsson, M. Meyer, S. Parkvall, J. Torsner, and M. Wahlqvist, "Technical solutions for the 3G long-term evolution," *IEEE Communications Magazine*, vol. 44, no. 3, pp. 38–45, Mar. 2006.
- [15] H. Ekstrom, "QoS control in the 3GPP evolved packet system," *IEEE Communications Magazine*, vol. 47, no. 2, pp. 76–83, Feb. 2009.
- [16] D. Tse and P. Viswanath, *Fundamentals of Wireless Communication*, Cambridge University Press, May 2005.
- [17] R. G. Gallager, *Information Theory and Reliable Communication*, John Wiley & Sons, Inc., 1968.
- [18] D. Tse and S. Hanly, "Multiaccess fading channels – Part 1: Polymatroid structure, optimal resource allocation and throughput capacities," *IEEE Transactions on Information Theory*, vol. 44, no. 7, pp. 2796–2815, Nov. 1998.
- [19] L. Li and A. Goldsmith, "Capacity and optimal resource allocation for fading broadcast channels – Part 1: Ergodic capacity," *IEEE Transactions on Information Theory*, vol. 47, no. 3, pp. 1083–1102, Mar. 2001.
- [20] D. Tse, "Optimal power allocation over parallel Gaussian broadcast channels," *unpublished, available at www.eecs.berkeley.edu/~dtse/broadcast2.pdf*.
- [21] Y. Liang and V. Veeravalli, "Gaussian orthogonal relay channels: Optimal resource allocation and capacity," *IEEE Transactions on Information Theory*, vol. 51, no. 9, pp. 3284–3289, Sept. 2005.
- [22] Y. Liang, V. Veeravalli, and H. Vincent Poor, "Resource allocation for wireless fading relay channels: Max-min solution," *IEEE Transactions on Information Theory*, vol. 53, no. 10, pp. 3432–3453, Oct. 2007.
- [23] A. Reznik, S. R. Kulkarni, and S. Verdú, "Broadcast-relay channel: Capacity region bounds," in *Proceedings IEEE International Symposium on Information Theory (ISIT)*, Sept. 2005, pp. 820–824.
- [24] Y. Liang and V. Veeravalli, "Cooperative relay broadcast channels," *IEEE Transactions on Information Theory*, vol. 53, no. 3, pp. 900–928, Mar. 2007.
- [25] W. Mesbah and T. Davidson, "Power and resource allocation for orthogonal multiple access relay systems," in *Proceedings IEEE International Symposium on Information Theory (ISIT)*, July 2008, pp. 2272–2276.
- [26] W. Mesbah and T. Davidson, "Power and resource allocation for orthogonal multiple access relay systems," *EURASIP Journal on Advances in Signal Processing, Special Issue on Cooperative Wireless Networks, Article ID 476125*, vol. 2008, pp. 1–15, 2008.
- [27] H. Viswanathan and S. Mukherjee, "Performance of cellular networks with relays and centralized scheduling," *IEEE Transactions on Wireless Communications*, vol. 4, no. 5, pp. 2318–2328, Sept. 2005.
- [28] M. Kaneko, P. Popovski, and K. Hayashi, "Throughput-guaranteed resource-allocation algorithms for relay-aided cellular OFDMA system," *IEEE Transactions on Vehicular Technology*, vol. 58, no. 4, pp. 1951–1964, May 2009.
- [29] M. Salem, A. Adinoyi, M. Rahman, H. Yanikomeroglu, D. Falconer, and Y. Kim, "Fairness-aware radio resource management in downlink OFDMA cellular relay networks," *IEEE Transactions on Wireless Communications*, vol. 9, no. 5, pp. 1628–1639, May 2010.
- [30] M. Shaqfeh and N. Goertz, "Performance analysis of scheduling policies for delay-tolerant applications in centralized wireless networks," in *Proceedings IEEE International Symposium on Performance Evaluation of Computer and Telecommunication Systems (SPECTS 2008)*, June 2008, pp. 309–316.
- [31] M. Shaqfeh, N. Goertz, and S. McLaughlin, "Organizing multiuser operation in centralized wireless networks," in *Wireless World Research Forum Meeting 20*, Apr. 2008, pp. 1–6.
- [32] P. Viswanath, D. Tse, and R. Laroia, "Opportunistic beamforming using dumb antennas," *IEEE Transactions on Information Theory*, vol. 48, no. 6, pp. 1277–1294, June 2002.
- [33] M. Shaqfeh and N. Goertz, "Channel-aware scheduling with resource-sharing constraints in wireless networks," in *Proceedings IEEE International Conference on Communications (ICC)*, May 2008, pp. 4149–4153.
- [34] G. Song and Y. Li, "Utility-based resource allocation and scheduling in OFDM-based wireless broadband networks," *IEEE Communications Magazine*, vol. 43, no. 12, pp. 127–134, Dec. 2005.
- [35] X. Wang, G. Giannakis, and A. Marques, "A unified approach to QoS-guaranteed scheduling for channel-adaptive wireless networks," *Proceedings of the IEEE*, vol. 95, no. 12, pp. 2410–2431, Dec. 2007.
- [36] X. Wang and G. Giannakis, "Stochastic primal-dual scheduling subject to rate constraints," in *Proceedings IEEE Wireless Communications and Networking Conference (WCNC)*, Mar. 2007, pp. 1527–1531.
- [37] J. G. Proakis, *Digital Communications*, McGraw-Hill International Editions, third edition, 1995.
- [38] A. Goldsmith, *Wireless Communications*, Cambridge University Press, 2005.