

A Novel VSWR-Protected and Controllable CMOS Class E Power Amplifier for Bluetooth Applications

Wei Chen, Wei Lin, and Shizhen Huang

Abstract—This paper describes the design of a differential class-E PA for Bluetooth applications in 0.18 μm CMOS technology with load mismatch protection and power control features. The breakdown induced by load mismatch can be avoided by attenuating the RF power to the final stage during over voltage conditions. Power control is realized by means of “open loop” techniques to regulate the power supply voltage, and a novel controllable bias network with temperature compensated is proposed, which allows a moderate power control slope (dB/V) to be achieved. Post-layout Simulation results show that the level of output power can be controlled in 2dBm steps; especially the output power in every step is quite insensitive to temperature variations.

Index Terms—Power amplifier, class E, VCWR.

I. INTRODUCTION

BLUETOOTH devices operate in the 2400-2483.5MHz Industrial, Scientific and Medical (ISM) band. There are basically three classes based on the transmission distance. They are Class 1 (The transmitted output power is 20dBm), Class 2 (The transmitted output power is 4dBm) and Class 3 (The transmitted output power is 0dBm) respectively. Usually, the Bluetooth power amplifier is working in low power model, so the output power of Class 1 power amplifier must controllable down to 4dBm or less in a monotonic sequence to save the power [1].

A standard method of controlling the output power of a power amplifier is to use a voltage regulator to regulate the battery or power supply voltage. Typical approaches to controlling the output power of a power amplifier use an “open loop” or a “closed loop” control technique. “Closed loop” techniques use an RF sensor, such as a directional coupler, to detect the power amplifier output power. The detected output power is used in a feedback loop to regulate the output power. “Open loop” techniques control the output power by regulating either the power supply voltage or power supply current used by the power amplifier. “Open loop” techniques are popular since open loop techniques do not have the loss and complexity associated with RF sensor elements. But in conventional power control schemes by mean of regulating only power supply voltage, the PA gain control slope (dB/V) is precipitate and the PA will suffer from transmit burst shaping and potential stability problems.

Nowadays, Gallium Arsenide (GaAs), BiCMOS and silicon bipolar technologies still dominate in the power amplifier design. Compared with CMOS technology, these technologies

offer higher breakdown voltage, lower substrate loss and higher quality of monolithic inductors and capacitors, but they are expensive. CMOS technology, on the other hand, could provide single-chip solution which greatly reduces the cost. But CMOS technology suffers from poor quality factors of monolithic passive components, low breakdown voltage of the transistors and large process variation.

More still, the main obstacle to the actual exploitation of CMOS PAs is the ruggedness requirement, i.e., the ability to survive under high load voltage standing wave ratio (VSWR) conditions with a full-power RF drive [2]. Typically, device testing procedures for commercial PAs can demand a VSWR as high as 10:1 under a 5V power supply. Such a strong mismatch condition results in very high voltage peaks at the collector of the final stage (much higher than the nominal supply voltage) and may eventually lead to permanent failure of the power transistor due to avalanche breakdown. As reported in [3], to comply with ruggedness requirements, collector voltage peaks in excess of 16V have to be tolerated. CMOS transistors usually exhibit lower breakdown voltages. Thick gate-oxide transistors of TSMC 0.18 μm RF CMOS process have a 6.8V breakdown voltage.

In this paper, a two-stage 0.18 μm CMOS monolithic PA for Class 1 Bluetooth is proposed. The PA includes a power control circuit which can improve the PA gain control slope (dB/V) and a protection circuit to overcome the detrimental effects of load impedance mismatch. The level of output power can be controlled in 2dB steps using an open loop control technique and a novel linearity control bias network using temperature compensated, and achieved confirm that ruggedness specifications can be fulfilled.

II. CIRCUITS DESIGN

The power amplifier is designed in a 0.18 μm CMOS technology with analog and RF options. This CMOS technology has two kinds of transistors. Thick gate-oxide transistors, which are similar to 0.35 μm transistors, have a higher breakdown voltage. Thin gate-oxide transistors that are similar to 0.18 μm transistors have a higher Gm. So the thin gate-oxide transistors are chosen in driver stage to generate a larger signal to turn the transistor on and off. And the thick gate-oxide transistors used for out stage. Fig.1 shows a simplified power amplifier topology which contains three main modules, Class E power amplifier and Driver stag; Power control module and VSWR protect module.

All authors are with the Fujian Key Laboratory of Microelectronics & Integrated Circuits, Fuzhou University, Fujian Province, 350002, China PRC. E-mail: wchen@fzu.edu.cn.

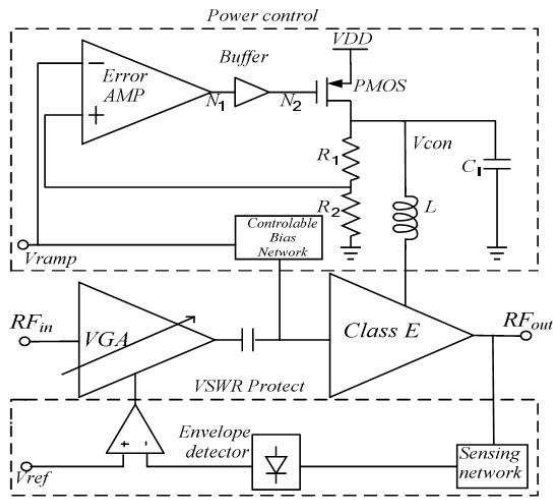

Fig. 1. Simplified power amplifier topology with power control and VSWR protection.

A. Class E Power Amplifier and Driver Stage For Bluetooth

Class E power amplifier is a switching-mode amplifier, which is nonlinear amplifier that achieves efficiencies approaching 100%. To achieve these conditions, all the components should be properly designed. As shown in Fig.2, the loading inductor L_6 is either a RF choke (RFC) or a finite inductance.

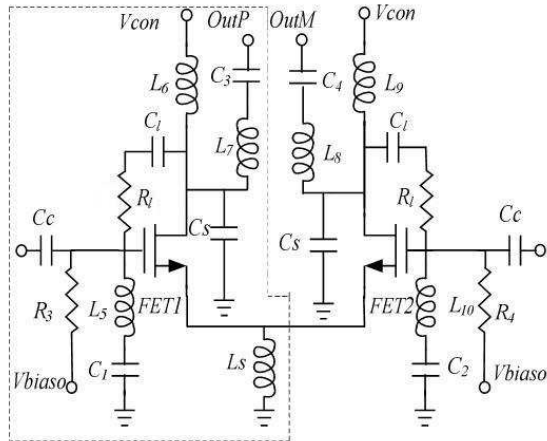

Fig. 2. Differential class E PA with finite ground inductance.

C_s is a charging capacitor; L_7 and C_3 are designed to be a series LC resonator with an excess inductance at the frequency of interest. The resonator resonates at the fundamental frequency, and suppresses the other harmonics. The purpose of LC resonator is designed for optimization conditions. The optimum values for each component are calculated as follows [4].

$$R_l = \frac{0.577(V_{dc} - V_{knee})^2}{P_{out}} \quad (1)$$

$$C_3 = \frac{1}{5.447\omega R_l} \quad (2)$$

$$L_7 = \frac{Q R_l}{\omega} \quad (3)$$

$$C_s = C_3 \times \frac{5.447}{Q} \left(1 + \frac{1.42}{Q - 2.08}\right) \quad (4)$$

where R_l is the optimize load, Q is the quality factor of LC resonator. Fig.3 shows a simplified circuit of drive stage in a

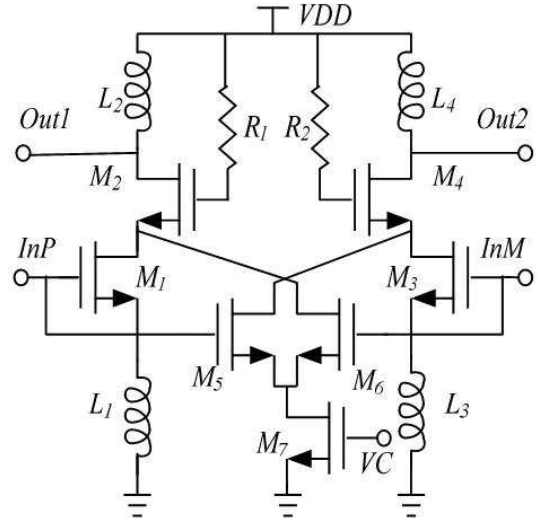

Fig. 3. Drive stage in a cascade topology.

cascade topology, which is to generate a larger signal to turn the transistor on and off. The variable-gain amplifier (VGA), which is operated at maximum gain under nominal conditions. When VC is in low voltage and M_7 turns off. When M_7 turns on, the gain of VGA will decrease, and attenuate the RF power to the final stage and the drain voltage of final transistors will decrease.

B. Open-loop Power Control for Class E Power Amplifier

The open-loop control system in which the output has no effect upon the input signal. The methodology to realize power controllable is to change the output stage power supply voltage in "open loop" control technique which is a likely LDO and to change the final stage bias by a novel controllable network temperature compensated. The benefit of using this topology is that the noise of its output voltage is lower and the response to input voltage transient and output load transient is faster. The output voltage V_{con} in Fig.1 can obtain from equation (5).

$$V_{con} = \left(1 + \frac{R_1}{R_2}\right) \times V_{ramp} \quad (5)$$

When the Bias of Class E is in a fixed station, the drive signal is an excellent switch signal, and not to consider other non ideal factors the output power P_{out} can be obtained from equation (6).

$$P_{out} = 0.577 \times \frac{V_{con}^2}{R_{load}} = 0.577 \times \left[\left(1 + \frac{R_1}{R_2}\right) \times V_{ramp}\right]^2 / R_{load} \quad (6)$$

Equation (6) shows that the output power P_{out} and the control signal V_{ramp} are in a square relationship. Actually to change the driven signal can improve PA gain control slope (dB/V). Fig.4 shows a simplified novel linearity controllable

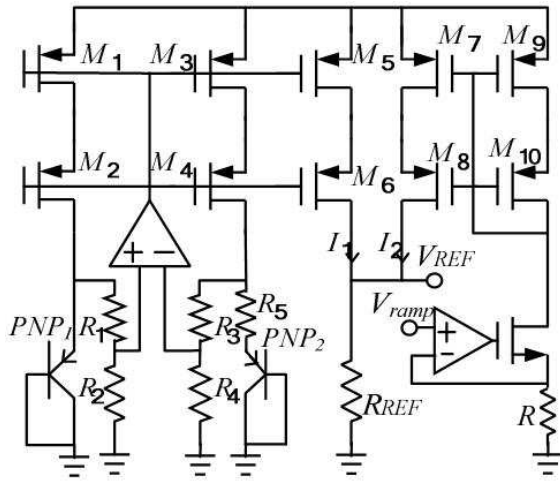

Fig. 4. Novel linearity controllable bias network with temperature compensated.

bias network with temperature compensated for final stage. The output voltage can be obtained from equation (7)

$$V_{REF} = a + a_1 \times V_{ramp} \quad (7)$$

It shows V_{REF} is controlled by V_{ramp} . Where

$$a = I_1 \times R_{REF} = \left(\frac{V_{BE1} \times R_{REF}}{R_3 + R_4} \right) + \left(\frac{V_T \ln n \times R_{REF}}{R_5} \right)$$

$$a_1 = \frac{I_2 \times R_{REF}}{V_{ramp}} = \frac{R_{REF}}{R} \times \left(\frac{W_9 / L_9}{W_7 / L_7} \right)$$

In normal temperature,

$$\frac{\partial V_{BE}}{\partial T} \approx -1.5 \text{ mV}/^\circ \text{K}, \quad \frac{\partial V_T}{\partial T} \approx +0.087 \text{ mV}/^\circ \text{K},$$

$$\frac{\partial a}{\partial T} = \left(\frac{R_{REF}}{R_3 + R_4} \times \frac{\partial V_{BE1}}{\partial T} \right) + \left(\frac{\ln n \times R_{REF}}{R_5} \times \frac{\partial V_T}{\partial T} \right)$$

The coefficient “ a ” and “ a_1 ” are constant, but “ a ” is proportional to temperature, and “ a_1 ” insensitive to temperature.

C. Closed-Loop Drain Peak Voltage Control

There is no isolator used between the PA and the antenna as a result the power amplifier can cause strong load mismatch due to faults or disconnection antenna. Therefore power transistors should be able to tolerate over voltage, as the peaks of drain voltage waveforms show much higher under mismatch conditions than under nominal conditions. The worst case conditions occur when the power amplifier is operated under both oversupply and load mismatch conditions. So the ruggedness specification is usually considered in terms of a maximum tolerable output VSWR under a specified oversupply condition. Typical data sheets of commercial power amplifiers guarantee that no permanent damage happened with 10:1 load VSWR under supply voltage of 5V.

The risk of breakdown can be prevented by simply attenuating the RF signal which drives the final stage during over voltage conditions [5], [6]. This can be achieved by adopting a feedback control system, which detects the peak voltage at

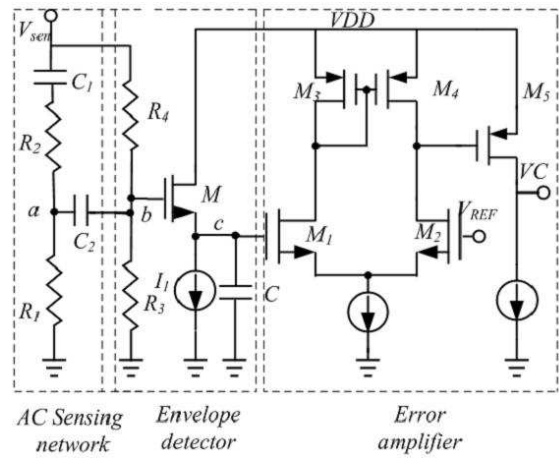

Fig. 5. Closed-loop drain peak voltage control.

the output collector node and decreases its value to a specific threshold by varying the circuit gain.

Drain voltage of the output transistor is scaled down by a high-input-impedance sensing network, the scaled down voltage is applied to an envelope detector delivering an output signal proportional to the collector peak voltage. An error amplifier then compares the rectified waveform voltage with a reference voltage. Finally, the output error is used to control the gain of the drive stage.

If $R_3(R_4) \gg R_2$ and capacitors C_1 and C_2 are large enough to be considered short circuits at the operating frequency, then the output voltage of rectifier (at node c) can be expressed as

$$V_c = (V_{sen(peak)} - V_{con}) \times \frac{R_1}{R_1 + R_2} + V_{con} \times \frac{R_3}{R_3 + R_4} - V_{gs}(M) \quad (8)$$

where $V_{gs}(M)$ is the voltage between the gate and the source of transistor M, $V_{sen(peak)}$ is the peak of the drain voltage of final stage transistor FET1, and V_{con} is the DC voltage of it. When the drain voltage of final stage transistor over the reconvered voltage, then V_c will exceed V_{REF} , and the VSWR protection will in work station.

III. LAYOUT DESIGN

The power amplifier was first layered out using Cadence Analog Artist, and then imported into ADS's Momentum RF 2.5d electromagnetic simulator. Pins are added to layout to define the current flow direction, the polygons are meshed into rectangles and triangles, and the dielectric properties of the substrate are defined. Fig.6 shows layout of differential class E with on chip input and inter-stage matching. The circuit is then simulated using the planar field solver. The layouts of RF devices, especially for power amplifiers, require special attention. The output transistor carries 250mA of dc current, plus the RF current, and out stage transistors (M_8 and M_9) has a total width of 2.4mm. The drain contact area of each transistor is enlarged, and parallel layers of metal 1 to metal 5 are used as drain and source connections such that the device is able to handle large currents. The output devices are placed as close as possible to the output pads. Many bond-wires can

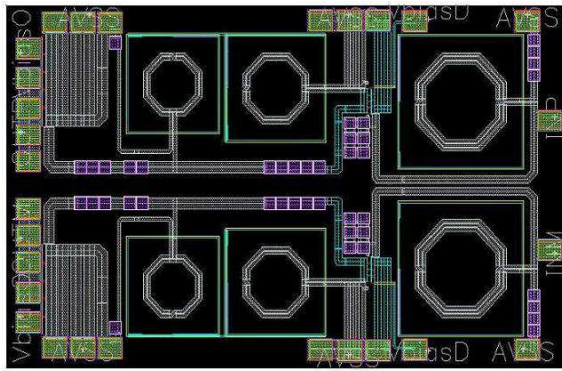

Fig. 6. Layout of differential class E with on chip input and inter-stage matching.

handle the large output currents. 14 ground pads were used in order to minimize the ground bond-wire inductance.

IV. SIMULATION RESULTS

The PA in Fig. 1 was simulated and optimized by using ADS (Advanced Design System) in 0.18 μ m technology, and the Bond wire inductance is replaced by a physical lumped element model. Fig.7 shows the output power (Spectrum) vary

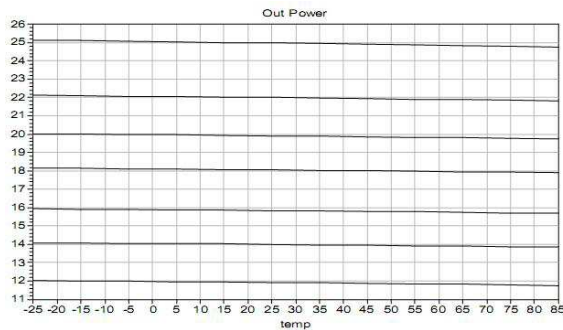

Fig. 7. Output power vary with temperature.

with Temperature, it indicates that the output power changes less than 0.3dBm when the temperature vary from -25 $^{\circ}$ C to 85 $^{\circ}$ C. Fig.8 shows the PAE and Output power (Spectrum) vary

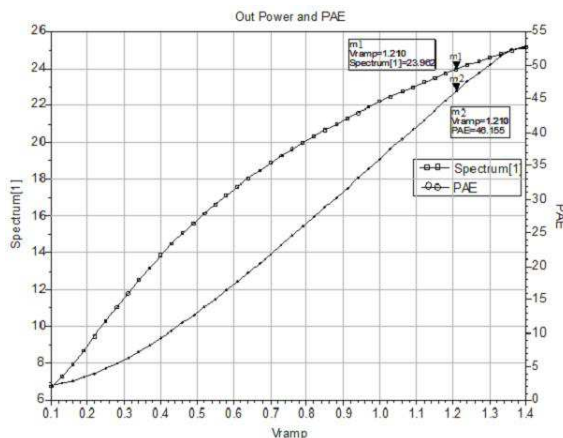

Fig. 8. The output power and PAE vary with control voltage.

with the control voltage V_{ramp} . When used 0dBm input signal and 1.8V supply voltage at 2.45GHz the PA reached to the maximum output power of 25.1dBm and 54.2% power-added efficiency (PAE). Fig.9 shows the drain voltage of FET1 would

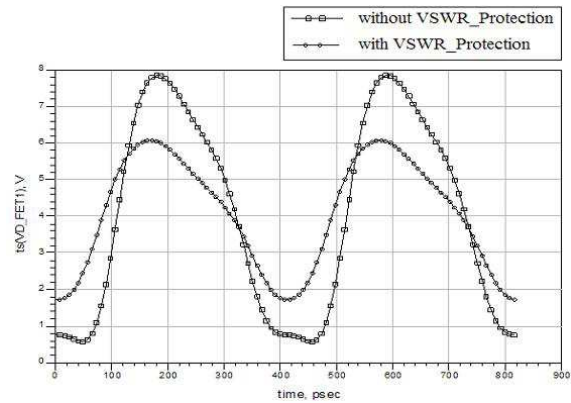

Fig. 9. Drain voltage of FET1 under over power supply and load mismatch.

reach much higher more than 6.8V without VSWR protection when the supply voltage is 5V and the load resistance is 5 Ω , then the transistor FET1 will breakdown. But the transistor will be in safe station with VSWR protection.

V. CONCLUSION

A two stage of class-E power amplifier for class 1 Bluetooth applications has been designed which includes a protection circuit preventing output stage failure due to severe load mismatch. Safe operation was achieved through the use of a feedback loop that acts on the circuit gain to limit the overdrive of the output transistor whenever an over voltage condition is detected. The output power can be controlled easily by a variable supply implemented by “open loop” technique; also a novel bias network controlled by “ V_{ramp} ” with temperature compensated for final stage is proposed which allows a moderate power control slope (dB/V) to be achieved. Post-layout simulation a 25.1dBm output power and 54.2% PAE were achieved at a nominal 1.8V supply voltage. The amplifier is able to sustain a load VSWR as high as 10:1 up to a 5V supply voltage without exceeding the breakdown limits. And the level of output power can be controlled in 2dBm steps; especially the output power in every step is quite insensitive to temperature variations. And it is satisfied for Bluetooth applications.

ACKNOWLEDGMENT

The authors would like to thank the teachers in Fujian key Laboratory of Microelectronics & Integrated Circuits, they are very kind and patient, and would like to thank Fujian Integrated Circuit Design Center for the use of their facilities. The project was supported by the Natural Science Foundation of China (Grant No. 10871221).

REFERENCES

- [1] V. Vathulya, T. Sowlati, and D. M. W. Leenaerts, "Class-1 Bluetooth power amplifier with 24-dBm output power and 48% PAE at 2.4 GHz in 0.25 μ m CMOS", in *Proc. of 27th European Solid-State Circuits Conf.*, pp. 84-87, 2001.
- [2] A. Scuderi, F. Carrara, and G. Palmisano, "VSWR-protected silicon bipolar power amplifier with smooth power control slope", in *Proc. IEEE Int. Solid-State Circuits Conf.*, pp. 194-195, Feb. 2004.
- [3] K. Yamamoto *et al.*, "A 3.2-V operation single-chip dual-band Al-GaAs/GaAs HBT MMIC power amplifier with active feedback circuit technique", *IEEE J. Solid-State Circuits*, vol. 35, no. 8, pp. 1109-1120, Aug. 2000.
- [4] N. Sokal and A. Sokal, "Class E - A New Class of High-Efficiency, Tuned Single-Ended Switching Power Amplifier", *IEEE J. Solid-State Circuits*, vol. 10, no. 3, pp. 168-176, June 1975.
- [5] A. Scuderi, F. Carrara, A. Castorina, and G. Palmisano, "A high performance RF power amplifier with protection against load mismatches", in *Proc. IEEE MTT-S Dig.*, pp. 699-702, Jun. 2003.
- [6] A. van Bezooijen, F. van Straten, R. Mahmoudi, and A. H. M. van Roermond, "Over-temperature protection by adaptive output power control", in *Proc. IEEE 36th Eur. Microwave Conf.*, pp. 1645-1647, Sep. 2006.



Wei Lin was born in Fuzhou, Fujian in 1968. He received M.S. degree from Fuzhou University in 1998. He is currently employed by Physics and Information Engineering, Fuzhou University. His current interests include analog integrated circuits design and sensor technology research.



Wei Chen was born in Putian, Fujian in 1977. He received M.S. degree in College of Physics and Information Engineering from Fuzhou University in 2007. He is currently employed by Physics and Information Engineering, Fuzhou University. His current interests include analog integrated circuits design and sensor technology research.



Shizhen Huang was born in Fujian in 1968. He received M.S. degree from Fuzhou University in 2002. He is currently employed by Physics and Information Engineering, Fuzhou University. His current interests include analog integrated circuits design and sensor technology research.