

D0 Silicon Microstrip Tracker

Sergey Burdin for D0 Collaboration

Abstract—The D0 Run II silicon microstrip tracker (SMT) has 3 square meters of Si area. There are 792,576 channels read out by 6192 SVXIIe chips on 912 read out modules. The SMT provides track and vertex reconstruction capabilities over the full pseudorapidity coverage of the D0 detector. The full detector has been running successfully since April 2002.

This presentation covers the experience in commissioning and operating, the recent electronics upgrade which improved stability of the SMT and estimates of the radiation damage.

Index Terms—Detector, Silicon, Tracker, Electronics, Radiation.

I. INTRODUCTION

THE Silicon Microstrip Tracker (SMT) together with the Central Fiber Tracker (CFT) provide tracking and vertexing at the D0 Detector (Tevatron, Fermilab). The long interaction region and large pseudorapidity acceptance ($|\eta| < 3$) led to a hybrid design of the SMT shown in Fig. 1, with barrel detectors measuring primarily the r -coordinate and disk detectors which measure r - z as well as r - ϕ . Thus tracks for high p_T particles are reconstructed by the disks, and tracks of particles at small values of p_T are measured in the barrels. The SMT information is heavily used for many D0 analyses. It is crucial for selection of the events with t - and b -quarks, as well as for e^+e^- separation.

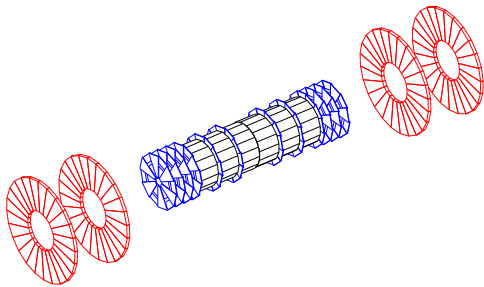

Fig. 1

ISOMETRIC VIEW OF THE D0 SILICON TRACKER

The SMT consists of six barrels which are 12 cm long and have 72 ladders arranged in four layers. The two outer barrels have single sided and double sided 2 stereo ladders. The four inner barrels have double sided double metal (DSDM) 90 stereo and double sided (DS) 2 stereo ladders. The ladders are mounted between two precision machined Beryllium bulkheads.

Presented at Nuclear Science Symposium & Medical Imaging Conference
S. Burdin (burdin@fnal.gov) is with Fermilab.

Each barrel is capped with a disk of wedge detectors, called the “F-disks”. The F-disks are comprised of twelve wedges made of double sided silicon wafers with trapezoidal shape. The stereo angle of the F-wedges is 30°. To provide further coverage at intermediate p_T , the central silicon system is completed with a set of three F-disks on each side of the barrel. In the far forward and backward region two large diameter “H-disks” provide tracking at high p_T . The H-disks are made of 24 pairs of single sided detectors glued back to back giving a stereo angle of 15°.

II. SILICON MICROSTRIP TRACKER READOUT

The silicon detectors are read out using the SVXIIe chip, which is fabricated in the UTMC radiation hard 1.2 μ m CMOS technology. Each chip consists of 128 channels, each including a preamplifier, a 32 cell deep analog pipeline and an 8 bit ADC. It features 53 MHz readout speed, sparsification, downloadable ADC ramp, pedestal and bandwidth setting. The SVXIIe chips and associated circuitry are mounted on a double-sided, 0.2 mm pitch, kapton flex circuit, the so called High Density Interconnect, or HDI. The HDI is laminated onto a 300 μ m thick Beryllium substrate and glued to the silicon sensor. In case of double-sided silicon ladders, the HDI is wrapped around one silicon edge to serve both ladder surfaces. The total number of HDIs in the SMT is 912.

Fig. 2 shows a sketch of the SMT readout setup. The HDIs are connected through 2.5m long kapton flex cables, Adaptor Cards (ACs) and 10m long pleated foil cables to Interface Boards (IBs). The ACs are located on the face of the Central Calorimeter. The IBs supply and monitor power to the SVXII chips, distribute bias voltage to the sensors and refresh data and control signals traveling between the HDIs and the Sequencers. The Sequencers control the operation of the chips and convert their data into optical signals carried over 1Gb/s optical links to VME Readout Buffer boards. Data is read out from the chips, transferred to the VRBs through the Sequencers whenever a Level-1 accept is issued and held pending a Level-2 trigger decision.

The SMT has been fully functional since April 2002. The main operational goal is to keep high efficiency with low detector downtime. This goal is compromised by unstable HDIs: 46% of all HDIs were deactivated at least once due to readout problems. In most cases these HDIs can eventually be read out. The debugging process is complicated because there is no access to the upstream electronics starting from the Sequencers during Tevatron operation; only during shutdown one can access the electronics and cables up to the Adaptor Cards.

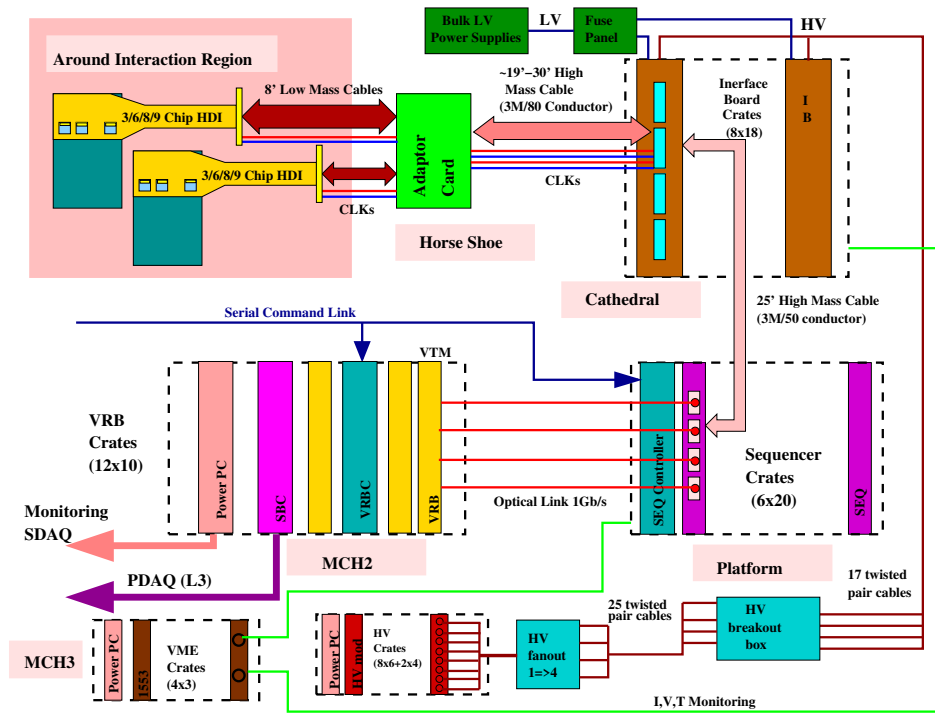

Fig. 2
SMT READOUT.

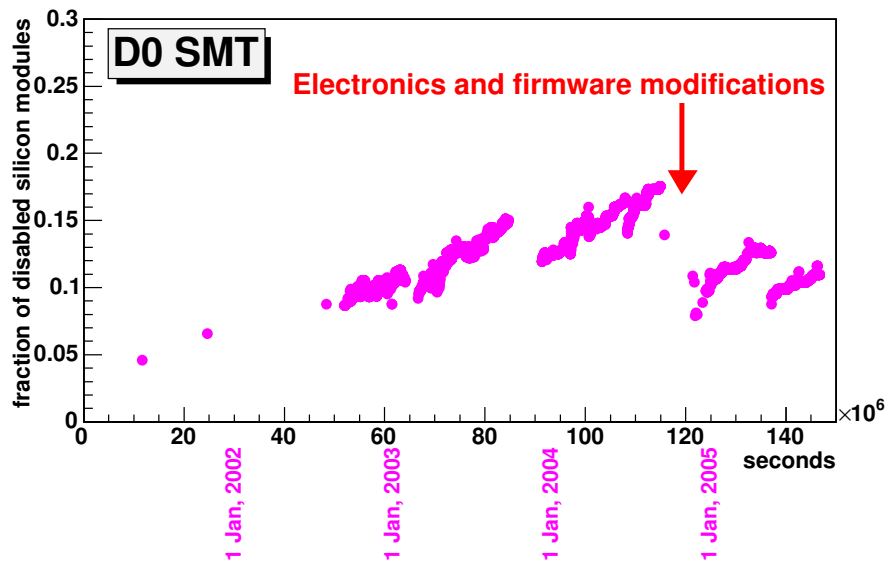

Fig. 3
FRACTION OF DISABLED SILICON MODULES VS. TIME.

Before the Fall 2004 shutdown 160 HDIs were disabled and 80 of them were declared “dead” due to confirmed problems in the unaccessible area. During the shutdown two approaches were used to fix the unstable HDIs. The traditional approach

was to check the accessible electronic chains. In addition, special changes in the Sequencer firmware were implemented to provide more stable readout.

Many HDI failure modes lead to loss of a proper end

of readout signal from the HDI, thus stopping data taking. To address this issue, special Sequencer firmware has been developed, which aborts the readout if there is no activity on the signal lines for a certain amount of time. These changes and more stable procedures for the chip parameter download allowed us to enable many of the unstable HDIs. Immediately after shutdown only 80 HDIs (10% from the total number) were disabled (see Fig. 3). In Spring 2005 this number had grown to 120 HDIs. Then another firmware modification was introduced, applying a readout abort if the elapsed time exceeds the maximum time needed for full HDI readout. This firmware upgrade again brought the number of disabled silicon modules down to 10% . Taking into account HDIs with partial readout, the overall fraction of working SVX chips is close to 83% .

The electronics upgrade has not only improved the silicon tracker efficiency but also significantly decreased the downtime caused by the silicon readout failures.

III. RADIATION DAMAGE

It is expected that the lifetime of the D0 Silicon Tracker will be limited by noise due to micro-discharge breakdown [1] in the inner layers. The micro-discharge effect depends on bias voltage and becomes unacceptable at approximately 150 volts. Double sided silicon detectors require sufficient bias voltage to fully deplete the entire silicon volume. This depletion voltage changes with the radiation dose received by the detectors. To predict the lifetime of the D0 Silicon Tracker it is necessary to monitor the depletion voltage and the radiation dose. The inner layer of the inner four barrels consists of the DSDM silicon modules which were measured to be the most sensitive to the radiation [2]. In addition, the inner layer receives the highest radiation dose. Therefore, our study is concentrated on the DSDM silicon modules in the inner layer.

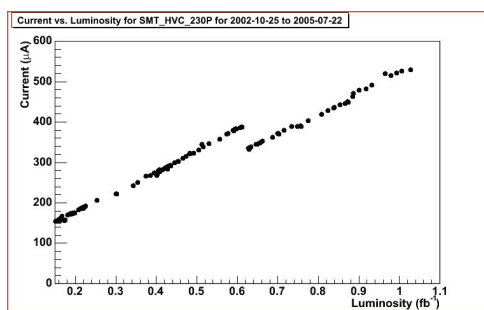

Fig. 4

EVOLUTION OF THE LEAKAGE CURRENT NORMALIZED TO 20 °C WITH INTEGRATED LUMINOSITY.

The radiation dose received by a silicon module can be measured using the leakage current, which depends on flux according to the following formula:

$$I = I_0 + \gamma \Phi V; \quad (1)$$

where I_0 is the leakage current before irradiation, γ is the radiation damage coefficient, Φ is the particle flux and V

is the detector volume. The coefficient γ depends on the particle type, temperature and time [3], [4]. The particle flux is proportional to the integrated luminosity delivered by the Tevatron. Therefore the dependence of the leakage current on the luminosity is also expected to be linear (see Fig. 4). The drop in the leakage current at the luminosity 0.6 fb^{-1} is due to the shutdown in Fall 2004 when the silicon tracker was warmed up to 15 °C for one month and annealing processes accelerated. The inner silicon layer has two sub-layers: the inner sub-layer at radius $27 \pm 1.5 \text{ mm}$ and the outer sub-layer at radius $36 \pm 4.5 \text{ mm}$. The radiation dose collected by the outer sub-layer is about 1.6 times lower than the one at the inner sub-layer. Measurements of several silicon modules in the inner layer gave a normalized particle flux from $4.0 \cdot 10^{17}$ to $5.3 \cdot 10^{17}$ particles= $\text{cm}^2 \text{fb}^{-1}$, taking annealing parameters from [4] and an asymptotic radiation damage constant of $3 \cdot 10^{17} \text{ A cm}^{-1}$. The spread reflects the accuracy of the method as well as possible non-uniformity of the radiation dose.

The silicon detector bulk material at D0 is slightly n-doped. Under radiation, however, donor states are removed and acceptor states created, eventually leading to a change from positive to negative space charge, i.e. the silicon bulk goes from being n-doped to becoming p-doped. This phenomenon is referred to as *type inversion* and is confirmed by many experiments. It was predicted that the type inversion at the D0 silicon bulk material will happen when the integrated normalized particle flux will reach approximately $5 \cdot 10^{17}$ particles= cm^2 [2]. The Tevatron has delivered slightly more than 1 fb^{-1} and, therefore, the inner layer should be at the type inversion point, where the depletion voltage is minimal.

The depletion voltage can be measured using the dependence of the noise level on the n-side of a silicon module as well as the dependence of charge collection efficiency on the bias voltage.

A. Noise level on the n-side

While the silicon bulk material is n-doped, the noise of the n-side strips is large and constant at all voltages below the depletion voltage, and reduces significantly when depletion is reached. Thus studying the n-side noise as a function of bias voltage can be used for determination of the depletion voltage.

In a bias voltage scan 11 runs are taken, with the high voltage settings varied from 0 to 100% in steps of 10%. The bias voltage scans were performed with and without beams in the Tevatron. The beam presence does not affect the measured depletion voltage values.

The DSDM and DS sensors show very different noise behavior as a function of bias voltage. For that reason, different procedures are used for DSDM and DS devices.

The observed difference in noise behavior could come from the more complicated design of the DSDM devices [5]. In order to read out the n-side strips, an additional metal layer is needed. The second metal layer is insulated from the first with a very thin layer of PECVD (plasma enhanced chemical vapor deposition). If there is a charge build-up in the insulation

layer, this could change the behavior of the noise as a function of the bias voltage.

The DSDM devices show a rather unexpected noise behavior as a function of bias voltage (see Fig. 5). There is no abrupt decrease in the noise level on the n-side when the depletion voltage is reached. Instead, the noise is decreasing rather monotonically with increasing bias voltage. For some HDIs a small kink in the noise can be seen at a certain bias voltage, and the position of this kink is changing as a function of the radiation dose. We interpret this kink as an indication of the depletion voltage.

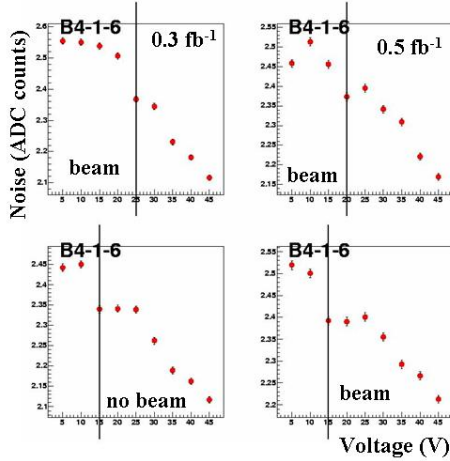

Fig. 5

DISTRIBUTION OF NOISE LEVEL ON THE N-SIDE AS A FUNCTION OF BIAS VOLTAGE FOR A DOUBLE SIDED DOUBLE METAL SILICON MODULE INSTALLED IN THE D0 DETECTOR. THE BIAS VOLTAGE SCANS AT DIFFERENT INTEGRATED LUMINOSITIES ARE SHOWN.

The n-side noise was measured at a non-irradiated test DSDM module (see Fig. 6) and abnormal behavior was not observed. This measurement indicates that the abnormal noise behavior is caused by the irradiation, and the comparison with the DS modules shows that the radiation changes some properties of the PECVD layer.

Most of the DS devices show the expected noise behavior as a function of bias voltage (see Fig. 7). At low voltages the noise is large, and rapidly decreases to a stable and lower level as soon as the bias voltage reaches the depletion voltage. There is some indication of noise increase at bias voltages higher than the depletion voltage at higher radiation doses.

B. Charge collection efficiency

Another method for determination of the depletion voltage uses the dependence of charge collection efficiency on bias voltage. For the silicon detectors with n-doped bulk material, the charge collection efficiency measured on the p-side increases with bias voltage and reaches its maximum at full depletion. Though there could be some additional small increase after that, for example, due to change in the charge collection time.

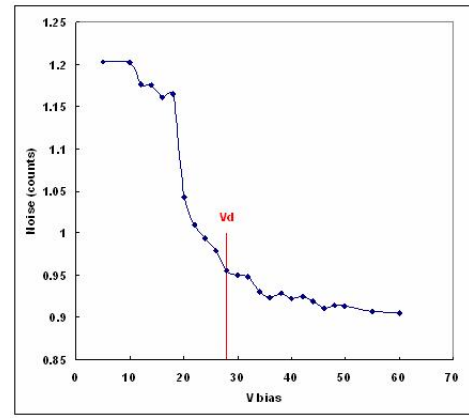

Fig. 6

DISTRIBUTION OF NOISE LEVEL ON THE N-SIDE AS A FUNCTION OF BIAS VOLTAGE FOR A NON-IRRADIATED DOUBLE SIDED DOUBLE METAL TEST MODULE.

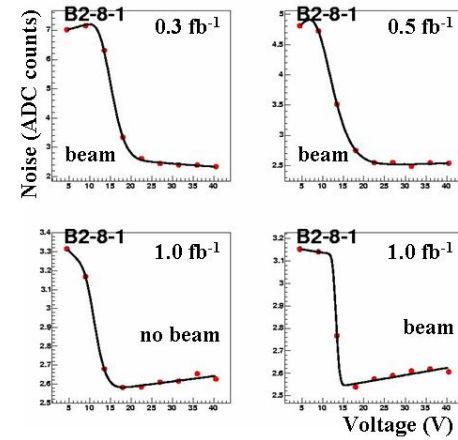

Fig. 7

DISTRIBUTION OF NOISE LEVEL ON THE N-SIDE AS A FUNCTION OF BIAS VOLTAGE FOR A DOUBLE SIDED SILICON MODULE INSTALLED IN THE D0 DETECTOR. THE BIAS VOLTAGE SCANS AT DIFFERENT INTEGRATED LUMINOSITIES ARE SHOWN.

This method requires bias voltage scans with tracks in the detector. A special algorithm has been developed for cluster reconstruction on the ladder under study in the vicinity of the expected track position. To determine the charge collection efficiency the cluster charge is measured. The bias voltage where the charge collection efficiency reaches 95% of its asymptotic value has been chosen as the depletion voltage (see Fig. 8).

The depletion voltage measured using the charge collection efficiency shows agreement with the noise measurements (see Fig. 9). The silicon modules also have been measured at a laser test-stand before they have been installed in the D0 detector. The corresponding initial depletion voltage is also shown in

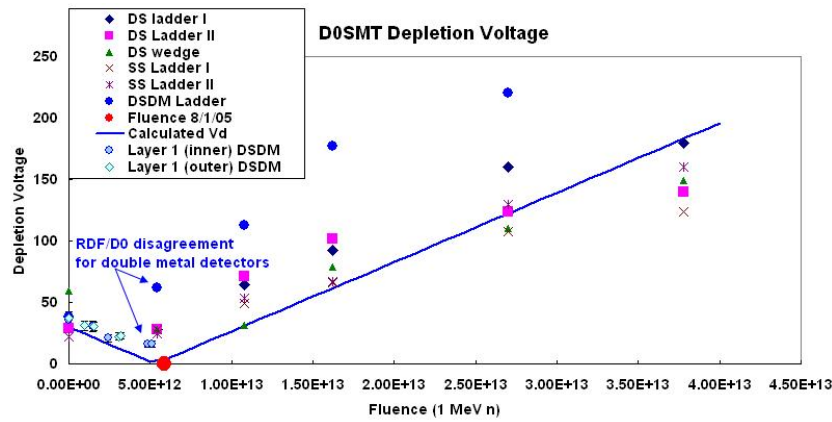

Fig. 10

DEPLETION VOLTAGE FOR THE SILICON MODULES INSTALLED IN THE D0 DETECTOR AND IRRADIATED AT THE RADIATION DAMAGE FACILITY FOR DIFFERENT RADIATION DOSES. THE LINE REPRESENTS A THEORY PREDICTION ACCORDING TO [3].

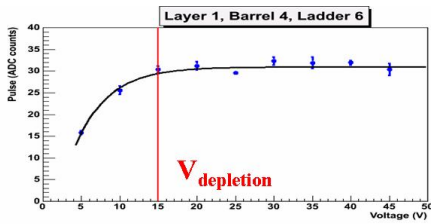

Fig. 8

DEPENDENCE OF THE CHARGE COLLECTION EFFICIENCY ON BIAS VOLTAGE FOR THE DOUBLE SIDED DOUBLE METAL SILICON MODULE INSTALLED IN THE D0 DETECTOR.

comparison in Fig. 10 shows that the DSDM silicon modules irradiated at RDF and those installed in the D0 Detector have a different dependence of the depletion voltage on the radiation dose. The depletion voltage for the DSDM irradiated sensors increases much faster than for the single metal double sided silicon detectors tested at RDF. From our measurement, the initial behavior of depletion voltage for the DSDM silicon modules installed in the D0 Detector is similar to the behavior of the single metal double sided modules and is well described by standard parameterizations [3]. The discrepancy is probably due to slow annealing of charge trapped in the insulator layer between metal layers which was not measured in the RDF studies. Assuming this “normal” behavior continues, the depletion voltage for the DSDM silicon sensors at the inner layer will reach values around 150 volts at a delivered luminosity of $5\text{--}7 \text{ fb}^{-1}$.

Fig. 9.

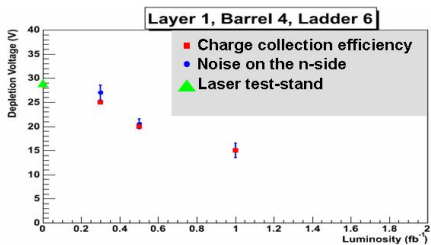

Fig. 9

COMPARISON OF DEPLETION VOLTAGES DETERMINED BY TWO METHODS.

IV. CONCLUSION

The D0 Silicon Tracker has been working successfully since April 2002. Recent electronics and firmware upgrades improved its efficiency and stability. Depletion voltage measurements for the inner DSDM silicon modules show the expected radiation damage of the silicon bulk material. The thin layer of plasma enhanced chemical vapor deposition, which is used for insulation of two metal layers in the DSDM sensors, is affected by the radiation as well. This causes abnormal n-side noise behavior and probably biases the depletion voltage measurements for the DSDM silicon modules irradiated at the Radiation Damage Facility. If the silicon tracker lifetime is limited by only the depletion voltage and the breakdown does not happen until bias voltages $\sim 150 \text{ V}$, then the D0 silicon tracker will stay operational up to delivered luminosities of $5\text{--}7 \text{ fb}^{-1}$.

ACKNOWLEDGMENT

This work is presented on behalf of the D0 Collaboration. The author would like to thank John Omotani (University of

C. Lifetime estimate

The measurements of the radiation dose and depletion voltage allow us to compare the behavior of the silicon sensors installed in the D0 Silicon Tracker with the ones irradiated at the Radiation Damage Facility (RDF) at Fermilab. The

Cambridge, UK), who has made significant contributions to the leakage current study while a summer student at the D0 experiment.

REFERENCES

- [1] R. Lipton, *D0 Internal Note 4077*, Lifetime of the D0 Silicon Tracker.
- [2] J. Gardner et al., *D0 Internal Note 3962*, Results from irradiation tests on D0 Run2a Silicon Detectors at the Radiation Damage Facility at Fermilab.
- [3] M. Moll, PhD Thesis, University of Hamburg, 1999.
- [4] R. Wunstorf, Radiation Hardness of Silicon Detectors: Current Status, *IEEE Transactions on Nuclear Science*, Vol. 44, No. 3, June 1997.
- [5] F. Lehner, *D0 Internal Note 3846*, The construction and performance of the 6-chip silicon ladders for the D0 silicon main tracker.