

# COMBINATORICS OF MULTIBOUNDARY SINGULARITIES $B_n^l$ AND BERNOULLI–EULER NUMBERS.

KARPENKOV O.

## Introduction.

In [1,2] V. I. Arnold in particular established the connection between the components of the space of very nice M-morsifications for boundary singularities  $B_n$  and the combinatorics of corresponding Springer cones; the number of the components equals Bernoulli–Euler number  $K_n$ .

In this note we regard the generalization of the boundary singularities  $B_n$  of the functions on the real line to the case where the boundary is a finite number of ( $l$ ) points. These singularities  $B_n^l$  could also arise in higher dimensional case, when the boundary is an immersed hypersurface.

We obtain some recurrence relation on the numbers of connected components of very nice M-morsification spaces with different values of  $n$  and  $l$ .

The author is grateful to V. I. Arnold, V. M. Zakalukin and S. K. Lando for useful discussions and attention to this work.

## Main notions and definitions.

**Definition 1.** A *very nice M-morsification of a multiboundary singularity*  $B_n^l$  is a polynomial with all its critical points being real. All critical values and all values at the boundary points  $x = b_i$  are also different.

Note that we enumerate the boundary points, otherwise we regard the factorization of  $\mathbb{R}^k$  over the action of the group of coordinate permutations. We enumerate the boundary points, since they correspond to the different preimages, and this preimages don't permute.

**Definition 2.** The *M-domain* is a closed subset of the space of polynomials

$$x^n + \lambda_2 x^{n-2} + \dots + \lambda_{n-1} x$$

consisting of polynomials which critical points are real.

The set of very nice M-morsifications is an open set in  $\mathbb{R}^{n-2} \times \mathbb{R}^l$ . The closure of this set is  $(M\text{-domain}) \times \mathbb{R}^l$ . It is subdivided into connected components by the bifurcation diagram, containing five hypersurfaces. Three of these hypersurfaces may occur in the case of the ordinary boundary singularities  $B_n$  (see also [2]):

- (a): the boundary caustic consisting of functions with a boundary critical point;
- (b): the ordinary Maxwell stratum consisting of functions with equal critical values at different points;

---

This paper was partially supported by RBRF-00-15-96084 and RBRF-01-01-00803 projects.

- (c): the boundary Maxwell stratum consisting of functions having some value at the boundary equals some critical value (the corresponding critical point is not at the boundary).

Notice that  $B_n = B_n^1$ . Moreover, the boundary point does not fixed. So the definition of the very nice M-morsification of the boundary singularity  $B_n$  in the paper [2] is the special case of Definition 1.

Two new hypersurfaces occur in the case of the multiboundary singularities  $B_n^l$ ,  $l \geq 2$ :

- (d): the double boundary caustic consisting of functions with some double boundary point;  
 (e): the double boundary Maxwell stratum consisting of functions with equal values at different boundary points.

Consider an example of the multiboundary singularity  $B_3^2$  (Fig. 1) Here we regard the family of polynomials  $x^3 + \lambda x$  with boundary points  $x = b_1$  and  $x = b_2$ . The M-domain is a half-space with coordinates  $(\lambda, b_1, b_2)$ ,  $\lambda \leq 0$ . The hypersurfaces are marked with the following symbols:  $a$  — the boundary caustic,  $c$  — the boundary Maxwell stratum,  $d$  — the double boundary caustic,  $e$  — the double boundary Maxwell stratum,  $f$  — the ordinary caustic.

There is no Maxwell stratum here, since for any polynomial of the third power with real critical values the equivalence of critical values implies the equivalence of critical points.

### The recurrent equation and some its corollaries.

By  $K_n$  we denote Bernoulli–Euler numbers (here is the beginning of this sequence, the first number corresponds to  $n = 0$ : 1, 1, 1, 2, 5, 16, 61, ...). By  $K_n^l$  we denote the quantity of connected components of the very nice M-morsification spaces for the singularity  $B_n^l$ . Bernoulli–Euler numbers are the boundary conditions for the numbers  $K_n^l$ , that is  $K_n^0 = Z_{n-2}$  and  $Z_n^1 = K_{n+1}$  (See [1]).

**Theorem.** The following equation on the numbers  $K_n^l$  holds:

$$K_{n-2}^{l+1} = K_n^l - nlK_n^{l-1}.$$

To proof this theorem we need to use the  $\sigma$ -shaped functions, as it makes in case of the boundary singularities  $B_k$  (See [1]). In the paper [1] to any polynomial with boundary point adds the  $\sigma$ -shaped function concentrated in some neighborhood of the boundary point. It follows that there exists a one-to-one correspondence with the polynomials which has no boundary points and the degree of this polynomials is greater by two. Presence of another boundary points rather complicates the picture: the problem loses "up-down" symmetry. Thus, we either add or subscribe some  $\sigma$ -shaped function concentrated in the neighborhood of some point. We regard the case where some boundary value is greater than any critical value or conversely smaller than any critical value. Thus, we divide the proof on the cases of the polynomials of even and odd degree.

Finally, let us regard some corollaries of the theorem.

The exponential generating function for Bernoulli–Euler numbers is the function  $K(t) = \tan(t) + \sec(t)$ . Notice that for  $l = 0$  and  $l = 1$  we may consider  $K(t)$  as an exponential generating function, however with our notations it would be  $K_0(t) = \int K(t)dt =$

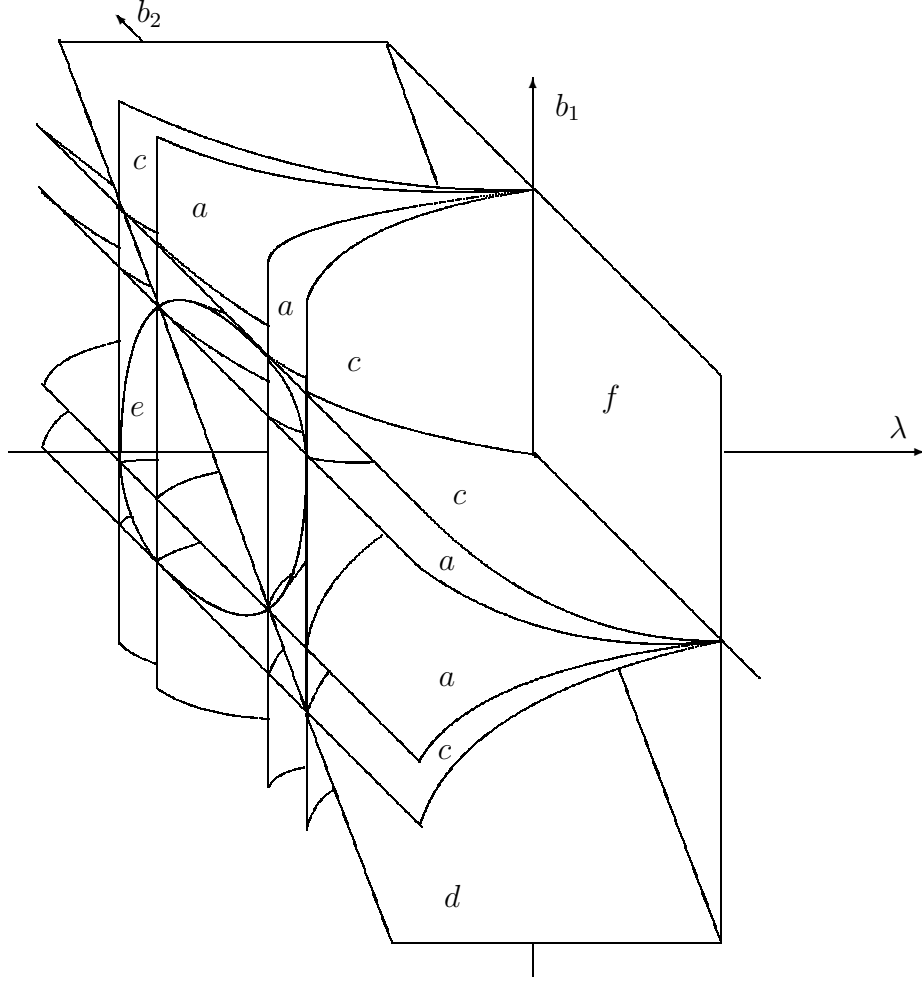

Fig.1 Bifurcation diagram of the M-domain for the singularity  $B_3^2$  ( $\lambda \leq 0$ ).

$-\ln(\cos(t)) + \ln(\tan(\frac{t}{2} + \frac{\pi}{4})) + C$  and  $K_1(t) = K'(t) = \frac{1+K^2}{2} = \frac{1+\sin(t)}{\cos^2 t} = \frac{1}{1-\sin(t)}$  respectively.

**Corollary 1.** The exponential generating functions for  $l = 7, 3, 4$  are the following:

$$\begin{aligned} K_2(t) &= \frac{3\sin(t) - t\cos(t)}{(1-\sin(t))^2}; \\ K_3(t) &= \frac{7}{(1-\sin(t))^3} \left( \sin(t)(3\sin(t) + 7) - t\cos(t)(5 + \sin(t)) \right); \\ K_4(t) &= \left( \frac{3t^2}{1-\sin(t)} - \frac{3t\cos(t)}{(1-\sin(t))^2} (3 - \sin(t)) + \frac{3(2-\sin(t))}{(1-\sin(t))^2} \right)^{(4)}. \end{aligned}$$

Consider the exponential generating function of two variables  $K(x, y) = \sum \frac{K_n^l}{l!n!} x^l y^n$ .

**Corollary 2.**  $K(x, y)$  satisfies the following differential equation:

$$K_x = (1 - 2x)K_{yy} - xyK_{yyy}.$$

At last we calculate the numbers  $K_n^l$  for  $n \leq 0$  using the relation of the theorem.

We may regard  $K_0^l$  as the number of connected components of the space of constant polynomials with  $l$  boundary points, where any polynomial has different values. Here all points of the real line are critical. So the critical value equals to any boundary value. We do not know what is the meaning of the numbers  $K_n^l$  for  $n < 0$ .

$K_n^l$	l=1	l=2	l=3	l=4	l=5
n=0	1	0	0	0	0
n=-1	1	0	0	0	0
n=-2	?	1	0	0	0
n=-3	?	?	2	0	0
n=-4	?	?	?	6	0
n=-5	?	?	?	?	24

Note that in any row all values are equal to zero starting from some certain index. Let us state this in the following corollary.

**Corollary 3.** Let  $n \leq -1$ , then  $K_n^l = 0$  for  $l > -n$ , and  $K_n^{-n} = (-n - 1)!$ .  $K_0^l = 0$  for  $l > 1$ .

The proof uses the statement of the theorem and carrying out by induction on  $n$ .

#### References.

- [1] V. I. Arnold, *Bernoulli-Euler updown numbers associated with function singularities, their combinatorics and arithmetics*, Duke Math. J., 1991, 63(2), 537-555.
- [2] V. I. Arnold, *Springer numbers and morsification spaces*, J. Algebraic Geom., 1992, 1(2), 197-214.