

Measurement of radiation-pressure-induced optomechanical dynamics in a suspended Fabry-Perot cavity

Thomas Corbitt, David Ottaway, Edith Innerhofer, Jason Pelc, and Nergis Mavalvala
LIGO Laboratory, Massachusetts Institute of Technology, Cambridge, MA 02139, USA

(Dated: November 1, 2021)

We report on experimental observation of radiation-pressure induced effects in a high-power optical cavity. These effects play an important role in next generation gravitational wave (GW) detectors, as well as in quantum non-demolition (QND) interferometers. We measure the properties of an optical spring, created by coupling of an intense laser field to the pendulum mode of a suspended mirror; and also the parametric instability (PI) that arises from the nonlinear coupling between acoustic modes of the cavity mirrors and the cavity optical mode. Specifically, we measure an optical rigidity of $K = 3 \times 10^4$ N/m, and PI value $R = 3$.

Second generation interferometric gravitational wave (GW) interferometers are anticipated to have in excess of 0.5 MW of circulating power in the long Fabry-Perot arm cavities [1]. High circulating power is needed to reduce the effect of photon counting statistics (shot noise) which limits the performance of these instruments at higher frequencies (above 200 Hz). In this high power regime, the assumption that the dynamics of the suspended masses and the light field used to measure their motion can be treated separately no longer applies, and a rich variety of physical phenomena result from radiation pressure effects. The radiation pressure effects include parametric instability (PI) [2, 3, 4, 5], optical tilt instability [6], quantum radiation pressure noise and the opto-mechanical rigidity [7, 8, 9]. In this Letter we report on the observation and characterization of two radiation pressure induced phenomena in a detuned Fabry-Perot cavity with mirrors suspended as pendulums: the optical spring effect and a PI. These measurements are in a frequency, mass and optical rigidity regime that differ from previous measurements by many orders of magnitude, and are of particular importance to GW detectors and quantum non-demolition (QND) devices.

The optical spring effect occurs in Fabry-Perot cavities that are detuned from resonance. When a cavity with movable mirrors is detuned, radiation pressure creates an optical restoring force that can significantly increase the force required to change the separation between two suspended cavity mirrors. This increased rigidity, and the associated optical spring, modifies the response function of the mirror modes. At frequencies below the optical spring resonant frequency, the response of cavity length to external disturbances (e.g., driven by seismic and/or thermal forces) is suppressed by the increased rigidity factor. This suppression factor makes the optical spring an important feature of QND interferometers [8, 10]. The optical spring effect also occurs in Advanced LIGO [7]. The response of these opto-mechanically stiffened oscillators is also predicted to be unstable [9].

The optical spring effect has been previously demonstrated on a 1.2 g mass held in a flexure mount [11].

In that experiment the mechanical resonance of the mass/flexure structure at 303 Hz was altered by 3% with the application of radiation pressure force, corresponding to an optical rigidity of about 150 N/m. In the experiment reported here, 0.25 kg mirrors are suspended as pendulums with a resonant frequency of 1 Hz for the longitudinal mode (motion along the optic axis of the cavity). With detuning of the cavity, the resonance is shifted upwards by nearly 2 orders of magnitude. We also confirm the unstable nature of the resonance.

In recent years there has been some debate on the potential of PIs to adversely impact the performance of second generation GW interferometers. The risk of PIs in future detectors arises from the high circulating power and the low mechanical loss (high quality factor, or Q) materials planned for use in future test masses. High mechanical Q materials are required to limit the effect of thermal noise on the sensitivity of the device [12].

The PI process is as follows: light circulating inside a Fabry-Perot cavity is phase modulated due to the vibrations of a mirror mechanical mode. The phase modulation creates a pair of sidebands equally spaced on either side of the carrier at the mechanical mode frequency. If the cavity has an asymmetric optical response to these sidebands, one will experience a greater build-up than the other, and they will not be balanced. An imbalance in these sidebands will result in a fluctuating amplitude and hence an oscillating radiation pressure force. If the upper sideband (anti-Stokes mode) is favored then cold damping of the mechanical mode occurs, in which the mechanical quality factor of the mode is reduced. If the lower sideband (Stokes mode) is favored, a run-away process may occur when the rate at which the mechanical mode is pumped by the Stokes mode is greater than the rate that energy is lost by mechanical dissipation.

Braginsky et al. [2] first reported on the danger of PIs in high power GW detectors. They suggested that for kilometer-scale cavities with high circulating power and low free spectral range (fsr), a Stokes mode at the fsr could cause the cavity to become unstable. They also warned that the density of mechanical modes around the

fsr of the cavity could overlap with a higher order mode of the cavity, leading to instability. Application to realistic interferometers by Zhao et al. [5] has confirmed that there are likely to be modes with sufficient parametric gain to be unstable.

Parametric instabilities have been observed in resonant bar detectors with microwave resonator readouts [13] and in optical micro-cavities [14]. Kippenberg et al. observed radiation-pressure-induced parametric oscillation instabilities in ultrahigh-Q toroidal optical microcavities, at frequencies of 4.4 to 49.8 MHz and modal masses of 10^{-8} to 10^{-9} kg. The experiment reported in this Letter differs from these experiments in that it demonstrates PI at 28.188 kHz, in a suspended cavity apparatus with an effective mass of 0.23 kg. The mass and frequency regime of this experiment are of particular relevance to GW detectors [1] and ponderomotive squeezing experiments [8, 10].

Since the PI and optical spring described in this Letter both arise from radiation pressure of the fundamental mode of the intracavity field, we present a simple unified model for both effects. Our model gives similar results to that of Braginsky et al. [4], who define a dimensionless PI susceptibility, R . Since the level of PI depends on the relative excitation of the Stokes and anti-Stokes mode, Braginsky et al. consider both the cold damping effect of the anti-Stokes and parametric amplification of the Stokes mode.

In our experiment, the Stokes and anti-Stokes modes experience different optical gains. They occur under the same optical resonance, but one that is detuned for the carrier frequency. The PI occurs because a Stokes mode in the TEM₀₀ spatial mode beats with the carrier in the same spatial mode, and interacts with the acoustic mode of the mirror. Because our experiment does not involve higher order spatial modes, we can construct a simple, unified model that describes both the optical rigidity and the PI. Defining $s = j\Omega$, where Ω is the measurement frequency, the optical rigidity is given by [8, 10]

$$K(s) = -K_0 \frac{\gamma^2}{(\gamma + s)^2 + \delta^2}, \quad (1)$$

where

$$K_0 = \frac{4\omega_0 I_0 (\delta/\gamma)}{c^2} \left[\frac{4}{\mathcal{T}_I} \frac{1}{1 + (\delta/\gamma)^2} \right]^2, \quad (2)$$

and γ is the cavity linewidth, δ is the detuning of the cavity from resonance, I_0 is the power incident on the cavity, and \mathcal{T}_I is the transmission of the cavity input mirror. The response of the mirror to a driving force near a resonance may be modelled as a simple harmonic oscillator with a mechanical resonant frequency Ω_0 ,

$$P(s) = \frac{1}{M_{\text{eff}}} \times \frac{1}{s^2 + \Omega_0^2 + s(\Omega_0/Q_m)}. \quad (3)$$

We define the effective mass according to

$$M_{\text{eff}} \equiv \frac{Q_m}{\Omega_0^2 \mathcal{R}}, \quad (4)$$

where \mathcal{R} is the displacement per force at Ω_0 , averaged over the laser beam. The motion of the mirror surface creates a phase shift of the light in the cavity. Since the cavity is detuned from resonance, the unbalanced propagation of the upper and lower sidebands is converted into an intensity modulation of the intracavity power. This, in turn, pushes back against the mirror surface. The optical rigidity, therefore, forms an optical feedback system, with a modified response

$$P(s)' = \frac{P(s)}{1 - P(s)K(s)}. \quad (5)$$

Though it is not strictly valid in our experiment, it is illustrative to consider the case where $s \ll \gamma$ and $\delta \ll \gamma$:

$$P(s)' \approx \frac{1}{M_{\text{eff}}} \times \frac{1}{s^2 + \Omega_0'^2 + s(\Omega_0'/Q')}, \quad (6)$$

where

$$\Omega_0'^2 = \Omega_0^2 + \frac{K_0}{M_{\text{eff}}}, \quad (7)$$

$$\frac{Q'}{Q_m} = \left(1 + \frac{K_0}{M_{\text{eff}}\Omega_0^2} \right)^{1/2} \left[1 - \frac{2K_0 Q_m}{M_{\text{eff}}\gamma\Omega_0} \right]^{-1}. \quad (8)$$

From Eqs. (3) and (6), we see that the response of the closed system is identical to that of a harmonic oscillator, with a modified resonant frequency Ω_0' and quality factor Q' . The R value defining the stability of the system, corresponding to definition in Ref. [4], can be found by the relations

$$Q' = \frac{Q_m}{1 - R} \quad \text{or} \quad \tau' = \frac{\tau_m}{1 - R}. \quad (9)$$

Here τ' and τ_m refer to the opto-mechanical and mechanical timescale for the ringing of the mode, respectively. In our system, we consider two modes of the mirror in two different frequency regimes. The first mode is the pendulum motion of the mirrors. For this case, the optical rigidity is much greater than the gravitational restoring force, such that $K_0 \gg M_{\text{eff}}\Omega_0^2$, $\Omega_0' \approx \sqrt{K_0/M_{\text{eff}}}$, and $Q' \approx -\frac{\gamma}{2\sqrt{K_0/M_{\text{eff}}}}$, which gives

$$R \approx 1 + \frac{2Q_m\sqrt{K_0/M_{\text{eff}}}}{\gamma}. \quad (10)$$

We note that the resonant frequency is shifted ($\Omega_0' \rightarrow \Theta$), and the resonance is inherently unstable ($R > 1$), with a quality factor Q' independent of Q_m .

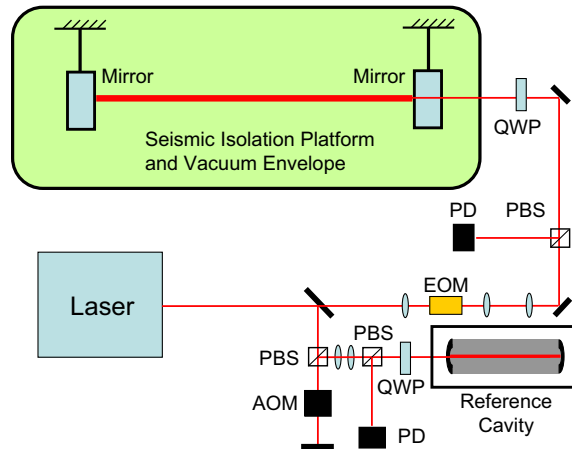

FIG. 1: Schematic representation of the experiment, showing the 1 m long Fabry-Perot cavity suspended in vacuum. Abbreviations are acousto-optic modulator (AOM), electrooptic modulator (EOM), photodiode (PD), polarizing beam splitter (PBS), and quarter-wave plate (QWP). Most of the 10 W output of the 1064 nm Nd:YAG laser light is directed to the suspended cavity. A small fraction of it is pick-off and frequency shifted by double passing through the AOM. The frequency shifted light is used to lock the laser frequency to the reference cavity resonance with high bandwidth (> 500 kHz). Frequency shifting via the AOM provides a means of high speed frequency modulation of the stabilized laser output; it is an actuator for further stabilizing the laser frequency with reference to the suspended cavity. The input mirror of the cavity has a transmission of 0.63%, giving a linewidth of 75 kHz. Not shown are feedback loops actuating on the cavity length and laser frequency (via the AOM).

The other mode is the acoustic drumhead motion of the mirror. For this mode, the optical restoring force is much less than the mechanical restoring force, such that $K_0 \ll M_{\text{eff}} \Omega_0^2$ and $\Omega'_0 \approx \Omega_0$, which gives

$$R \approx \frac{2 K_0 Q_m}{M_{\text{eff}} \gamma \Omega_0}. \quad (11)$$

For this mode, the resonant frequency does not change, but the Q of the mode may be altered, and may even be made negative so that the mode becomes unstable.

The experimental set-up used to observe the PI and the opto-mechanical rigidity is shown in Fig. 1. The experiment consists of a Fabry-Perot cavity comprising two 0.25 kg mirrors suspended by single loops of wire. The suspended mirrors are located in a vacuum chamber and are mounted on a three-layer passive vibration isolation system. The motion of the mirrors is controlled by forces due to small current-carrying coils placed near magnets that are glued to the back surface of each mirror.

Light from a frequency-stabilized laser is resonated inside the suspended Fabry-Perot cavity. Approximately 3.6 Watts of laser power is injected into the cavity. The

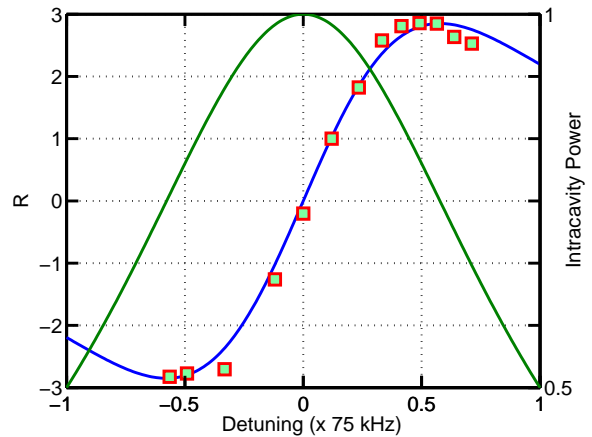

FIG. 2: The instability measure R is plotted as a function of detuning of the cavity from resonance, for fixed input power. The solid (blue) curve is the theoretical prediction, according to Eq. 11, with fit parameter M_{eff} ; the measured data are shown as colored squares. Also shown is the power built up in the cavity, normalized to unity (green curve).

Pound-Drever-Hall locking technique is used to hold the cavity on resonance (or detuned, with an injected offset).

To study the PI, we couple the drumhead mode at 28.188 kHz of one mirror to the optical fields. To measure the value of R for this mode as a function of detuning and power, it is necessary to measure ringup and ring-down times (τ' and τ_m in Eq. 9) of the mode for various detunings and input power levels. To ensure that the control system that keeps the cavity on resonance (or at the detuning point) does not interfere with the measurements, the length of the cavity is locked to the frequency of the laser with approximately 1 kHz bandwidth. A -60 dB notch filter at 28.188 kHz is added to the servo to eliminate any interference of the servo system with the measurement of the drumhead motion of the mirror. For the cases in which $R > 1$, we allow the mode to begin oscillating and capture the ringup of the mode and fit an exponential to find the timescale, and therefore the quality factor for the mode, which in turn gives the value of R . To measure values at $R < 1$, we first detune the cavity to a point where $R > 1$ and allow the mode to ringup, then quickly detune to the desired point and capture the ring down, and fit an exponential decay to find the value of R . The results of the measurements of R at various detunings, for a fixed input power, are shown in Fig. 2. The value of M_{eff} was treated as a free parameter that was fit to the data; we found a value of 0.227 kg. The measurements show good agreement with the predicted values. We also measured R as a function of cavity power, with fixed detuning (set to 75% of the maximum power), and established the linear dependence on power, also showing that R goes to zero at zero injected power.

Measuring the optical spring presented some chal-

lenges. The instability of the drumhead mode must be stabilized before the measurement can be performed. To accomplish this stabilization, we modify our servo so that we tune the frequency of the laser to follow the length of the cavity at frequencies from 300 Hz to 50 kHz. The modified servo system suppresses the formation of the 28.188 kHz sidebands that are an integral part of creating the PI. With sufficient suppression at 28.188 kHz, the drumhead mode will not be excited. The second difficulty is that the intrinsic motion of the mirrors at low frequencies is quite large and requires a strong servo system to hold the cavity on resonance. This has the unfortunate consequence of placing the optical spring resonance within the bandwidth of the servo system. The gain of the servo system explicitly depends on $P(s)'$, however, so by characterizing the servo system, $P(s)'$ is also characterized and the optical spring may be measured. The results from this measurement are shown in Fig. 3. We note that the transfer function is similar to that of a simple harmonic oscillator, with one important exception: that the resonance shows a negative damping constant (the phase *increases* by 180° at the resonance), as predicted by our model. We suspect that the smearing out of the sharp predicted peak in the data is caused by fluctuations of the intracavity power. The measured response is, however, consistent with the theoretical prediction, with no free parameters. From the measured frequency of the optical spring resonance, we infer the optical rigidity to be $K = 3 \times 10^4$ N/m.

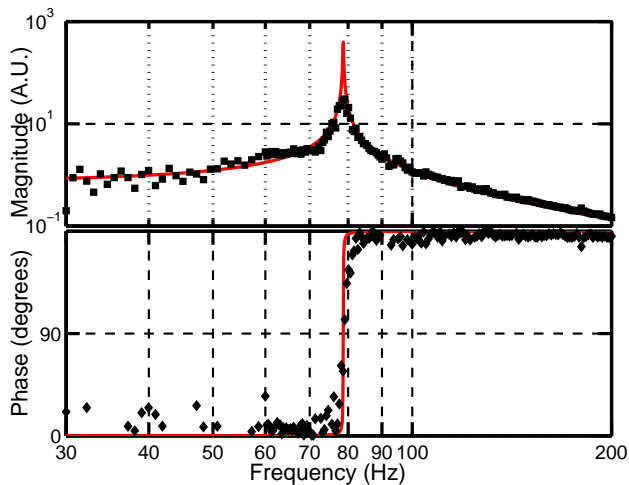

FIG. 3: The transfer function of applied force to displacement of the end mirror of the cavity, showing the optical spring resonance. The solid (red) curve is the theoretical prediction with no free parameters, based on measurement of the intracavity power, and the quadrangles are the measured data. The phase increases from 0 to 180 degrees at the resonance, showing that the resonance is unstable.

In summary, we have measured both the optical spring effect and a PI in a high-power Fabry-Perot cavity with mirrors suspended as pendulums. We find a maximum optical rigidity of $K = 3 \times 10^4$ N/m, and a PI with $R = 3$. Since the optical rigidity is a crucial element of an experiment to generate squeezed states using ponderomotive rigidity [8, 10], good agreement of our experiment with theory is valuable. The PI is an unwanted effect in that experiment, and its characterization and subsequent damping are important for the next phase of experimentation with higher finesse cavities and lighter mirrors. The PI identified and damped in this Letter is an extension of the work of the Vahala group [14] to much lower frequencies (by 4 to 5 orders of magnitude) and much higher effective mass (by 9 to 10 orders of magnitude). Similarly, the optical rigidity created in this experiment exceeds that of Sheard et al. [11] by 2 orders of magnitude. The measurements in this Letter are an important mass, frequency and optical rigidity regime for GW detectors and QND interferometers.

We would like to thank our colleagues at the LIGO Laboratory, especially D. Shoemaker for helpful comments on the manuscript. We gratefully acknowledge support from National Science Foundation grants PHY-0107417 and PHY-0457264.

-
- [1] P. Fritschel, *Gravitational Wave Detection, Proc. SPIE* **4856-39**, 282 (2002).
 - [2] V. B. Braginsky, S. E. Strigin, and S. P. Vyatchanin, *Phys. Lett. A* **287**, 331 (2001).
 - [3] W. Kells and E. d'Ambrosio, *Phys. Lett. A* **299**, 326 (2002).
 - [4] V. B. Braginsky, S. E. Strigin, and S. P. Vyatchanin, *Phys. Lett. A* **305**, 111 (2002).
 - [5] C. Zhao, L. Ju, J. Degallaix, S. Gras, and D. G. Blair, *Phys. Rev. Lett.* **94**, 121102 (2005).
 - [6] J. Sidles and D. Sigg, submitted to *Phys. Lett. A* (2004).
 - [7] A. Buonanno and Y. Chen, *Phys. Rev. D* **64**, 042006 (2001).
 - [8] T. Corbitt, Y. Chen, and N. Mavalvala, *Phys. Rev. A* **72**, 043819 (2005).
 - [9] A. Buonanno and Y. Chen, *Phys. Rev. D* **65**, 042001 (2002).
 - [10] T. Corbitt, Y. Chen, F. Khalili, D. Ottaway, S. Vyatchanin, S. Whitcomb and N. Mavalvala, submitted to *Phys. Rev. A* (2005). gr-qc/0511001.
 - [11] B. S. Sheard, M. B. Gray, C. M. Mow-Lowry, D. E. McClelland and S. E. Whitcomb, *Phys. Rev. A*, **69**, 051801 (2004).
 - [12] P. Saulson, *Phys. Rev. D* **42**(8), 2437, 1990
 - [13] B. D. Cuthbertson, M. E. Tobar, E. N. Ivanov, and D. G. Blair, *Rev. Sci. Instrum.* **67**, 2345 (1996).
 - [14] T. J. Kippenberg, H. Rokhsari, T. Carmon, A. Scherer and K. J. Vahala, *Phys. Rev. Lett.* **95**, 033901 (2005).