

2LS for Program Analysis

Daniel Kroening, Viktor Malík, Peter Schrammel and Tomáš Vojnar

1 Introduction

2LS ("tools") is a verification tool for C programs, built upon the CPROVER framework. It allows one to verify user-specified assertions, memory safety properties (e.g. buffer overflows), numerical overflows, division by zero, memory leaks, and termination properties.

The analysis is performed by translating the verification task into a second-order logic formula over bitvector, array, and floating-point arithmetic theories. The formula is solved by a modular combination of algorithms involving unfolding and template-based invariant synthesis with the help of incremental SAT solving.

Advantages of 2LS include its very fast incremental bounded model checking algorithm and its flexible framework for experimenting with novel analysis and abstraction ideas for invariant inference. Drawbacks are its lack of support for certain program features (e.g. multi-threading). Table 1 gives an overview of 2LS' features. The remainder of the chapter is structured as follows:

- Section 2 gives a high-level overview of the motivations and the theory behind 2LS' *verification approach*.

Daniel Kroening

University of Oxford, United Kingdom and Diffblue Ltd, United Kingdom e-mail: kroening@cs.ox.ac.uk

Viktor Malík

Faculty of Information Technology, Brno University of Technology, Czech Republic and IT4Innovations Centre of Excellence, Czech Republic, e-mail: imalik@fit.vutbr.cz

Peter Schrammel

University of Sussex, Brighton, United Kingdom and Diffblue Ltd, United Kingdom e-mail: p.schrammel@sussex.ac.uk

Tomáš Vojnar

Faculty of Information Technology, Brno University of Technology, Czech Republic and IT4Innovations Centre of Excellence, Czech Republic, e-mail: vojnar@fit.vutbr.cz

Table 1: Features of 2LS.

Languages	C, GOTO
Properties	assert, memory safety, overflow, division-by-zero, termination
Environments	Linux
Technologies used	symbolic execution, bounded model checking k-induction abstract interpretation template-based predicate synthesis ranking functions, recurrent sets SAT and SMT solving
Other features	multiple input files, compilation and linking of entire projects into GOTO via <code>goto-cc</code>
Current strengths	memory safety, floating point, loops
Current weaknesses	recursion, multi-threading

- Section 3 provides practical information on 2LS and *how to* use it for selected kinds of verification tasks, such as proving functional properties and checking for memory safety, termination and overflows.
- Sections 4–6 describe the underlying theoretical concepts behind 2LS.
- Section 7 provides details on the 2LS software project and its architecture.
- Section 8 reports data on experimental comparisons in the Software Verification Competition, in which 2LS has been participating since 2016.

2 Verification Approach

The software verification literature contains a wide range of techniques which can be used to prove or disprove properties about programs, each with their own strengths and weaknesses. This presents quite a challenge for non-expert users. Often the choice of which tools to use and where to expend effort depends on whether the properties to be verified are true or not—which is exactly what they want to find out. Hence, to build a robust and usable software verification system, it is necessary to combine a variety of techniques.

One option would be to run a series of independent tools, in parallel (as a portfolio, for example) or in some sequential order. However, this limits the information that can be exchanged between the algorithms.

Another option would be to use monolithic algorithms such as CEGAR [9], IMPACT [27], or IC3/PDR [3, 18] which combine some of the *ideas* of simpler systems. These are difficult to implement well as their components interact in complex and subtle ways. Also, they require advanced solver features such as interpolant generation that are not widely available for all theories (bit-vectors, arrays, floating-point, etc.). 2LS takes a different approach to the problem as explained below.

2.1 k -induction and k -invariants ($kIkI$)

2LS strives to build a verifier as a compound with simple components and well-understood interaction. These include:

Bounded Model Checking Given sufficient time and resource, BMC will give counterexamples for all false safety properties, which are often of significant value for understanding the fault. However, only a small proportion of true properties can be proven by BMC.

k -Induction Generalising Hoare logic’s ideas of loop invariants, k -induction can prove true safety properties, and, in some cases, provide counterexamples to false ones. However, it requires inductive invariants, which can be expensive (in terms of user time, expertise, and maintenance).

Abstract Interpretation The use of over-approximations makes it easy to compute invariants which allow many true propositions to be proven. However false properties and true-but-not-provable properties may be indistinguishable. Tools may have limited support for a more complete analysis.

2LS’s $kIkI$ algorithm [4] draws together a range of well-known techniques and combines them in a novel way so that they strengthen and reinforce each other. The k -induction technique [36] uses syntactically restricted or simple invariants (such as those generated by abstract interpretation) to prove safety. Bounded model checking [2] allows us to test k -induction failures to see if they are real counterexamples or, if not, to build up a set of assumptions about system behaviour. Template-based abstract interpretation is used for invariant inference [32, 31, 16] with unrolling producing progressively stronger invariants, allowing the techniques to strengthen each other.

$kIkI$ unifies these techniques in a simple and elegant algorithm for integrated invariant inference and counterexample generation. The main loop of $kIkI$ is based on incremental unwinding of the transition relation. In the k -th iteration, the transition relation is unwound up to depth k and a k -inductive invariant is inferred. The invariant is then used to strengthen the program’s safety property in order to find a proof for the program’s safety. In case that safety cannot be proved, the algorithm checks whether the current unwinding is sufficient to generate a counterexample. If this is not the case, the unwinding k is incremented and another iteration starts. The $kIkI$ algorithm is explained in more detail in Section 5.

Internally, 2LS reduces program analysis problems expressed in second order logic such as invariant or ranking function inference to synthesis problems over templates. Hence, it reduces (an existential fragment of) 2nd order Logic Solving to quantifier elimination in first order logic. Loop unwinding as used by bounded model checking and k -induction are considered as refinements of the original program abstraction. That way, 2LS provides an efficient implementation of $kIkI$ based on incremental loop unwinding, template-based predicate synthesis, and, ultimately, incremental SAT solving. These concepts, along with other important underlying concepts of 2LS are explained in more detail throughout Sections 4, 5, and 6.

```

1 void copy_authority(
2     char *uri, int uri_length, int authority_start, char *authority) {
3     __CPROVER_assume(0 < uri_length);
4     __CPROVER_assume(0 < authority_start && authority_start < uri_length);
5     int cp = authority_start;
6     while (cp != uri_length - 1) {
7         if (uri[cp] == '/')
8             break;
9         assert(cp < uri_length);
10        authority[cp - authority_start] = uri[cp];
11        ++cp;
12    }
13 }

```

Fig. 1: `uri.c`: numerical computations in a loop.

3 Use Cases

Before explaining the theoretical concepts behind 2LS, we give an overview of 2LS verification capabilities in the form of a tutorial. 2LS has a broad set of functionalities that allows the user to solve a variety of verification problems. We will use example programs, which can be found at <https://github.com/diffblue/2ls/tree/master/regression/book-examples>.

3.1 Proving Functional Properties

Functional properties can be specified in C programs with the help of assertions, as provided by `assert.h`. In order to state preconditions, the CPROVER framework provides the `__CPROVER_assume(cond)` function.¹

As a first example, let us consider the function in Figure 1, which extracts the authority part of a URI given as a character string `uri` into the buffer `authority`. We would like to ensure that we do not copy beyond the length of the URI, which is expressed by the assertion on line 9.

2LS provides various algorithms for verifying this property. For example:

- `2ls uri.c --function copy_authority --havoc`
2LS performs a 1-induction check using the invariant `true`. This is not sufficient to prove the property. Hence, it returns UNKNOWN.
- `2ls uri.c --function copy_authority --intervals`
2LS performs a 1-induction check using the interval invariants. This is still not sufficient. We get the result UNKNOWN.

¹ In order to keep the code compilable, this function can be surrounded by `#ifdef _CPROVER_ ... #endif`, which is defined when running 2LS.

- `2ls uri.c --function copy_authority --zones`
Using the stronger zones abstract domain, we are able to prove the property. 2LS outputs OK.
- `2ls uri.c --function copy_authority --octagons`
The even stronger octagons abstract domain allows us to prove the property, too. 2LS returns OK.
- `2ls uri.c --function copy_authority --havoc --k-induction`
2LS performs *k*-induction. This is sufficient to prove the property, even though we do not infer additional invariants (the havoc option). 2LS reports OK.

The example above dealt with numerical data. Let us now have a look at the program in Figure 2. This program allocates a singly-linked list of arbitrary length whose elements hold some integer value.² It then computes the minimum value held by the list elements and checks whether the minimum has been computed correctly, i.e., it must be smaller than or equal to all values in the list.

```

1 extern int __VERIFIER_nondet_int();
2
3 #include <stdlib.h>
4 #include <limits.h>
5
6 #define APPEND(l,i) {i->next=l; l=i;}
7
8 typedef struct node {
9     struct node *next;
10    int val;
11 } Node;
12
13 int main() {
14     Node *l = NULL;
15     int min = INT_MAX;
16
17     while (__VERIFIER_nondet_int()) {
18         Node *p = malloc(sizeof(*p));
19         p->val = __VERIFIER_nondet_int();
20         APPEND(l, p)
21
22         if (min > p->val)
23             min = p->val;
24     }
25     for (Node *i = l; i != NULL; i = i->next)
26         assert(i->val >= min);
27 }

```

Fig. 2: `min.c`: data stored in a dynamically allocated data structure.

² The `__VERIFIER_nondet_int` function is declared but does not have a definition. 2LS assumes that functions without definition return a non-deterministic value.

2LS can prove this thanks to combined reasoning about the shape of unbounded data structures and their contents at the same time. Running

```
2ls min.c --heap --values-refine
```

will return OK for the property on line 26³. This means that the assertion is not violated by any list of any size.

3.2 Finding Memory Safety Bugs

Another class of properties that can be verified using 2LS is that of memory safety properties. These include, e.g., array accesses within bounds, pointer dereference safety, free safety, or absence of memory leaks. 2LS performs verification of these properties by instrumenting the program with custom assertions. The complete list of available instrumentations can be seen by running 2LS with the `--help` option.

We demonstrate verification of memory safety properties on two examples. First, let us consider the program in Figure 3 which transforms a two-dimensional array `matrix` into a single-dimensional array `array`. We let the matrix dimensions to be random, but we add a precondition on line 7 assuring that the number of matrix elements fits the destination array.

```

1 #define SIZE 1000
2
3 int main()
4     int **matrix;
5     unsigned m = __VERIFIER_nondet_int();
6     unsigned n = __VERIFIER_nondet_int();
7     __CPROVER_assume(m <= SIZE && n <= SIZE && m * n <= SIZE);
8
9     int array[SIZE];
10    for (int row = 0; row < m; ++row) {
11        for (int col = 0; col < n; ++col) {
12            int index = row * m + col;
13            array[index] = matrix[row][col];
14        }
15    }
16    return 0;
17 }
```

Fig. 3: `matrix_to_vector.c`: array bounds safety.

Running the verification with

```
2ls --bounds-check --k-induction matrix_to_vector.c
```

³ The `--heap --values-refine` options employ a combination of shape and numerical domains.

will return FAILURE with an additional information about the particular generated assertion that failed:

```
[main.2] array 'array' upper bound in array[index]: FAILURE
```

This information says that `index` may be larger than the array's upper bound (`SIZE`). Furthermore, 2LS is able to provide a concrete counterexample in case it found a property violation. We may get this by re-running 2LS with an additional `--trace` option. An important part of the obtained trace is shown in Figure 4.

```
...
file main.c line 5 function main
  m=1000u
file main.c line 6 function main
  n=1u
...
file main.c line 10 function main
  row=1
file main.c line 11 function main
  col=0
file main.c line 12 function main
  index=1000
```

Fig. 4: Counterexample for array bound safety violation for program in Figure 3.

Using the counterexample, we discover an error on line 12, which should be:

```
12 int index = row * n + col;
```

Running the verification again after correcting the error returns OK, which means that no more out-of-bounds array accesses are present in the program.

For the second example of memory safety verification, we consider the program containing a dynamic memory allocation shown in Figure 5. The program allocates two memory objects pointed by pointers `a` and `b` and linked together (the value of the object pointed by `b` equals to `a` which points to a random integer). Afterwards, both allocated objects are freed. However, the freeing order is incorrect since `b` is freed first and an attempt to free the pointed object will likely fail due to an invalid dereference of a dangling pointer. 2LS can be used to verify absence of pointer dereference and of memory free errors by running

```
2ls --pointer-check --heap free_safety.c
```

As expected, running this command on the shown program returns FAILURE with an additional information about the error:

```
[main.11] dereference failure: deallocated dynamic object in *b: FAILURE
```

```

1 int main() {
2     int *a = malloc(sizeof(int));
3     *a = __VERIFIER_nondet_int();
4
5     int **b = malloc(sizeof(int *));
6     *b = a;
7
8     free(b);
9     free(*b);
10 }

```

Fig. 5: `free_safety.c`: free safety verification.

3.3 Termination and Nontermination

2LS can prove whether a program is terminating or whether it may not terminate under certain input conditions.

```

1 void bubble_sort(int *array, int size)
2 {
3     __CPROVER_assume(size >= 0);
4     int c, d, swap;
5
6     for (c = 0; c < size - 1; c++)
7     {
8         for (d = 0; d < size - c - 1; d++)
9         {
10            if (array[d] > array[d + 1])
11            {
12                swap = array[d];
13                array[d] = array[d + 1];
14                array[d + 1] = swap;
15            }
16        }
17    }
18 }

```

Fig. 6: `bubble_sort.c`: proving termination.

For example, Figure 6 shows an implementation of the bubble sort algorithm. We can check whether it terminates by running the following:

```
2ls bubble_sort.c --termination --function bubble_sort
```

We get an output of the following sort:

```
...
Summary for function bubble_sort
```



```

...
termination argument:
($guard#25 && ... ==> (-1 * (d#phi25 - d#30) + 0 * ...) > 0) &&
($guard#23 && ... ==> (-1 * (c#phi23 - c#32) + 0 * ...) > 0)
...
** Termination:
...
[bubble_sort]: yes
VERIFICATION SUCCESSFUL

```

2LS computes a termination argument in the form of a ranking function. The termination argument in the output above is heavily simplified to make it fit on this page. The actual termination argument output by 2LS has more elaborate guard constraints and casts to enable correct bitvector arithmetic without overflows. An inspection of the termination argument says that $-c$ is a ranking function for the outer loop and $-d$ is a ranking function for the inner loop, which proves termination of the `bubble_sort` function.

```

1 long sasum(long *sx, int n, int incx)
2 {
3     int nincx = n * incx;
4     long stemp = 0l;
5     int i;
6     for (i = 0; incx < 0 ? i >= nincx : i <= nincx; i += incx)
7     {
8         stemp += sx[i-1];
9     }
10    return stemp;
11 }

```

Fig. 7: `sasum.c` (cf. <http://www.netlib.org/clapack/cblas/sasum.c>).

2LS can also check for non-termination. It will do this by finding lasso-shaped executions. Figure 7 shows an array summation algorithm from a linear algebra package. Running

```
2ls sasum.c --function sasum --nontermination --trace
```

gives the output shown in Figure 8. Inspecting the counterexample trace, we see that variable `i` has the recurring value `0` on line 6, which implies non-termination of the loop because the loop condition can never become false. We can even see an example of input conditions under which this happens: `n=2, incx=0`.

In practice, one can run `--termination` and `--nontermination` in parallel and wait for the first to report a conclusive result.

```

Unwinding (k=1)
...
Nonterminating program execution proved after 1 unwinding(s)
...

Counterexample:

file sasum.c line 1
  n=2
file sasum.c line 1
  incx=0
...
file sasum.c line 6 function sasum
  i=0
...
file sasum.c line 6 function sasum
  i=0

VERIFICATION FAILED

```

Fig. 8: Output for the non-termination example.

3.4 Overflows

Another property that can be verified using 2LS is safety from integer overflows (and underflows). Similarly to memory safety verification, it is done by instrumenting the analysed program with custom assertions.

As an illustration, we use the program in Figure 6. In the program, the precondition `__CPROVER_assume(size >= 0)` on line 3 is necessary to avoid signed arithmetic underflows in computing `size - 1`, which would be an undefined behaviour in the C standards supported by 2LS. We can verify this by running 2LS to check for overflows:

```
2ls bubble_sort.c --signed-overflow-check --function bubble_sort
```

Without the precondition, we would get:

```

...
[bubble_sort.1] arithmetic overflow on signed - in size - 1: FAILURE
...
VERIFICATION FAILED

```

which confirms the necessity of the precondition.

4 Internal Program Representation

Being built upon the CPROVER infrastructure [8], 2LS uses *GOTO programs* as an intermediate representation. In this language, any non-linear control flow, such

as if or switch-statements, loops, or jumps, is translated to equivalent *guarded goto* statements. These statements are branch instructions that include (optional) conditions. CBMC generates one GOTO program per C function found in the parse tree. Furthermore, it adds a new main function that first calls an initialisation function for global variables and then calls the original program entry function.

Similarly to CBMC, 2LS performs a light-weight static analysis to resolve function pointers to a case split over all candidate functions, resulting in a static call graph. Furthermore, assertions guarding against invalid pointer operations or memory leaks are inserted. In addition, 2LS uses local constant propagation and expression simplification to increase efficiency.

After running the mentioned transformations, 2LS performs a static analysis to derive data flow equations for each function of the GOTO program. The result is a *static single assignment (SSA) form* in which loops have been cut at the back edges to the loop head. The effect of these cuts is havocking of the variables modified in the loop at the loop head. This SSA is hence an over-approximation of the GOTO program. Subsequently, 2LS refines this over-approximation by computing invariants.

Since this SSA representation is crucial for the verification approach of 2LS, we give its detailed description in Section 4.2. Prior to that, we introduce our memory model that is used to represent dynamically allocated objects in our SSA form (Section 4.1). At last, we give an insight into our loop unwinding approach, which is an important step of the *kIkI* algorithm, in Section 4.3.

4.1 Memory Model

We now describe a memory model that we use to represent all program memory [22]. Our model is object-based, and we distinguish objects allocated *statically* (i.e., variables on the stack and global variables) and *dynamically* (i.e., on the heap).

4.1.1 Static memory objects

In our approach, we work with non-recursive programs with all functions inlined. Therefore, we do not need to consider the stack and the set *Var* of static memory objects corresponds to the set of all program variables. Each variable is uniquely identified by its name.

For convenience, we define subsets of *Var* that correspond to sets of variables of a chosen type:

- *NVar* is the set of all variables of a numeric type (integer or floating point).
- *PVar* is the set of all variables of a pointer type.
- *SVar* is the set of all variables of a structure type. Each structure type defines a set of named *fields*, each of them having its own type. We use *Fld* to denote the set of all fields used in the analysed program. Similarly to the variables, we

let $NFld, PFld \subseteq Fld$ be the sets of all fields of numerical and pointer types, respectively. In order to express access to individual fields of a structure-typed variable, we use the “dot” notation as is common in C.

We assume $NVar$, $PVar$, and $SVar$ are pairwise disjoint.

4.1.2 Dynamic memory objects

To represent dynamic memory objects (i.e., those allocated using `malloc` or some of its variants), we use *abstract dynamic objects*. An abstract dynamic object represents a set of concrete dynamic objects allocated by the same `malloc` call. We refer to a `malloc` call at a program location i as to an *allocation site* i .

Generally, a single abstract dynamic object is not sufficient to represent all concrete objects allocated by a single `malloc` call. This is due to the fact that the analysed program may use several concrete objects allocated at the same allocation site at the same time. If such objects are, e.g., compared, our memory model must allow us to distinguish them. This can be done either by concretisation on demand (as is common in many memory models) or by pre-materialisation of a sufficient number of objects at the beginning of the analysis. Since our approach uses a single formula to represent the analysed program and leverages on small incremental changes of the formula during the analysis, we use the latter approach.

Therefore, we use the set $AO_i = \{ao_i^k \mid 1 \leq k \leq n_i\}$ of abstract objects to represent all concrete objects allocated at the allocation site i . The number n_i of necessary objects is determined for each allocation site using an approach described later in this section. The set of all dynamic objects of the analysed program is then defined as $AO = \cup_i AO_i$. Together with the set of all static objects, we define $Obj = Var \cup AO$ to be the set of all memory objects of our program abstraction. We require $Var \cap AO = \emptyset$ and $AO_i \cap AO_j = \emptyset$ for $i \neq j$.

Similarly to static objects, we denote NAO , PAO , and SAO the sets of dynamic objects of a numerical, pointer, and structure type, respectively. Fields of structure-typed dynamic objects, i.e., elements of the set $SAO \times Fld$, represent abstractions of the appropriate field of all represented concrete objects. Using the above sets, we may define the set Num of all *numerical objects* in the program as:

$$Num = NVar \cup NAO \cup ((SVar \cup SAO) \times NFld). \quad (1)$$

Analogically, we define the set Ptr of all *pointers* as:

$$Ptr = PVar \cup PAO \cup ((SVar \cup SAO) \times PFld). \quad (2)$$

Pointers can be assigned addresses of objects. Since we do not support pointer arithmetic, only *symbolic addresses* and a special address `null` are considered. We use the operator `&` to get the address of both static and dynamic objects. For abstract dynamic objects, the symbolic address is an abstraction of symbolic addresses of all represented concrete objects. We define the set $Addr$ of all addresses in the program

as:

$$Addr = \{\&o \mid o \in Obj\} \cup \{\text{null}\}. \quad (3)$$

Dynamic Object Pre-Materialisation

Above, we mentioned that, for each allocation site i , we represent (a potentially infinite number of) all objects allocated at i by a finite number n_i of abstract dynamic objects. In order for this abstraction to be sound, it is sufficient that this number is equal to the number of distinct concrete objects, allocated at i , that may be simultaneously pointed to at any location of the analysed program.

In order to compute this number, we first perform a standard static *may-alias analysis*. This analysis determines, for each program location j , the set P_i^j of all *pointer expressions* used in the program, that may point to some object allocated at i . Here, pointer expressions may be one of the following:

- Pointer variables.
- Dereferences of pointers to pointers. These correspond to pointer-typed dynamic objects.
- Pointer fields of structure-typed variables.
- Dereferences of pointers to structures followed by an access to a pointer-typed field. These correspond to pointer-typed fields of dynamic objects. Here, we use the C notation based on an arrow (e.g., $p \rightarrow n$ to express a dereference of p followed by an access to the field n of the pointed object).

For simplicity, we assume that all chained dereferences of forms $**p$ or $p \rightarrow f_1 \rightarrow f_2$ are split into multiple dereferences using an intermediate pointer variable which is added to $PVar$.

Next, we compute the must alias relation \sim_j over the set of all pointer expressions. For each pair of pointer expressions p and q and for each program location j , $p \sim_j q$ iff p and q must point to the same concrete object (i.e., they must alias) at j .

Finally, we partition each computed P_i^j into equivalence classes by \sim_j , and the number n_i is given by the maximal number of such classes for any j .

4.2 The Static Single Assignment Form

Program verification in 2LS is based on generating program abstractions using a solver. In order to simplify generation of a formula representing the program semantics, 2LS uses the *static single assignment form* (SSA) to represent programs. SSA is a standard program representation used in bounded model checking or symbolic execution tools. We use common concepts of SSA—introducing a fresh copy (version) x_i of each variable x at program location i in case x is assigned to at i , using the last version of x whenever x is read, and introducing a *phi* variable x_i^{phi} at a program join point i in case different versions of x come from the joined program branches.

For an acyclic program, SSA is a formula that represents exactly the post condition of running the code.

We extend the traditional SSA by three new concepts: (1) over-approximation of loops in order to make the SSA acyclic [4], (2) a special encoding of the control-flow [4], and (3) a special representation of memory-manipulating operations that comply with our memory model introduced in Section 4.1 [22]. In the rest of this section, we describe these extensions.

4.2.1 Over-Approximation of Loops

In order to be able to use a solver for reasoning about program abstractions, we extend the SSA by *over-approximating* the effect of loops. As was said above, the value of a variable x is represented at the loop head by a phi variable x_i^{phi} joining the value of x from before the loop and from the end of the loop body (here, we assume that all paths in the loop join before its end, and the same holds for the paths before the loop). However, instead of using the version of x from the loop end, it is replaced by a *free loop-back variable* x^{lb} . This way, the SSA remains acyclic, and, since the value of x^{lb} is initially unconstrained, the effect of the loop is over-approximated. To improve precision, the value of x^{lb} can be later constrained using a *loop invariant* that will be inferred during the analysis. A loop invariant is a property that holds at the end of the loop body, after any iteration and can be therefore assumed to hold on the loop-back variable.

For a better illustration, we give an example of this SSA extension. Figure 9 shows a simple loop in C and its corresponding SSA. Instead of using x_5 in the phi variable, a fresh variable x_6^{lb} is introduced. Moreover, the join in the phi node is driven by a free Boolean variable g_6^{ls} (a so-called *loop-select guard*) modelling a non-deterministic choice between x_6^{lb} and x_0 .

4.2.2 Encoding the Control-Flow

In 2LS, the program is represented by a single monolithic formula. It is therefore needed that the formula encodes control-flow information. This is achieved using so-called *guard* variables that track the reachability information for each program location. In particular, for each program location i , we introduce a Boolean variable g_i whose value encodes whether i is reachable. For example, in Figure 9, a guard g_5 encoding reachability of the loop body would have the value:

$$g_5 = x_3^{phi} < 10. \quad (4)$$

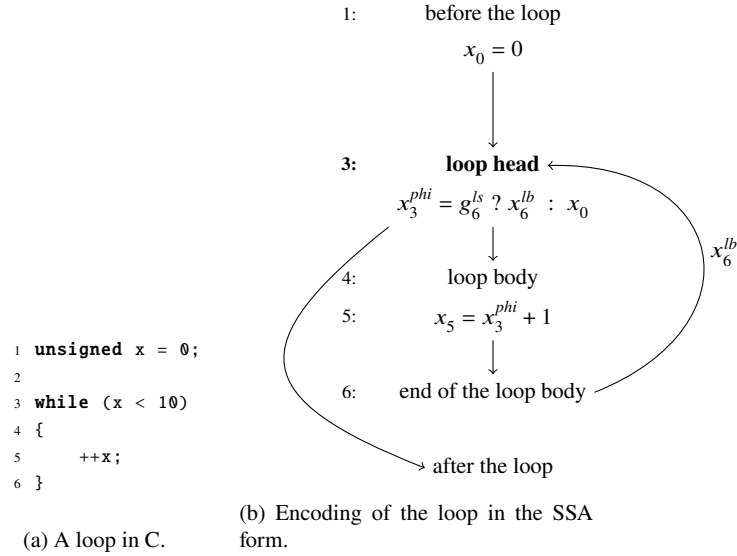

Fig. 9: Conversion of loops in the SSA form used in 2LS.

4.2.3 Representation of Memory-Manipulating Operations

Dynamic Memory Allocation

As said in Section 4.1, all concrete objects allocated by a single `malloc` call at a program location i are abstracted by a set of abstract dynamic objects AO_i . In the SSA form, we represent such a call by a non-deterministic choice among objects from AO_i . A program assignment $p = \text{malloc}(\dots)$ is therefore transformed into the formula

$$p_i = g_{i,1}^{os} ? \&ao_i^1 : (g_{i,2}^{os} ? \&ao_i^2 : (\dots (g_{i,n_i-1}^{os} ? \&ao_i^{n_i-1} : \&ao_i^{n_i}))) \quad (5)$$

where $g_{i,j}^{os}$, $1 \leq j < n_i$, are free Boolean variables, so-called *object-select guards*.

Reading through Dereferenced Pointers

We now describe encoding of a pointer dereference appearing on the right-hand side of an assignment or in a condition (i.e., in an R-expression). Prior to generating the SSA, we perform a static *may-points-to analysis* which over-approximates—for each program location i and for each pointer $p \in Ptr$ —the set of all objects from Obj that p may point to at i . A dereference of p at i is then represented by a choice among the pointed objects.

Moreover, to simplify the representation and to improve precision (for reasons explained below), we also introduce so-called *dereference variables*. Let $*p$ be an R-expression that appears at a program location i and let us assume that p may point to a set of objects $O \subseteq Obj$. We replace $*p$ by a fresh variable $drf(p)_i$, and we define its value as follows:

$$\begin{aligned} \bigwedge_{o \in O} p_j = \&o \implies drf(p)_i = o_k \wedge \\ \left(\bigwedge_{o \in O} p_j \neq \&o \right) \implies drf(p)_i = o_{\perp} \end{aligned} \quad (6)$$

where p_j and o_k are the relevant versions of the variables p and o , respectively, at the program location i , and o_{\perp} is a special “unknown object” representing the result of a dereference of an unknown or invalid (null) pointer.

Informally, (6) expresses the fact that $drf(p)_i$ equals the value of o at i in case that p points to o at i , and it equals the value of the unknown object otherwise.

Writing through Dereferenced Pointers

Similarly to the operation of reading, we introduce an SSA encoding for the operation of writing into memory using a pointer dereference. Again, we leverage on a may-points-to analysis described above, and we introduce special *dereference variables*. Let us have an assignment $*p = v$ at program location i and let us assume that p may point to a set of objects $O \subseteq Obj$ at the entry to i . This assignment is replaced by an equality:

$$drf(p)_i = v_i. \quad (7)$$

where v_i is the valid version of v at i . The dereference variable $drf(p)_i$ is then used to update the value of the referenced object. This is done using the formula:

$$\bigwedge_{o \in O} o_i = (p_j = \&o) ? drf(p)_i : o_k \quad (8)$$

where p_j, o_k are relevant versions of the variables p and o , respectively, at program location i .

In other words, this formula expresses the fact that an object o is assigned the value of v in the case when p points to o , and it keeps its original value otherwise. As mentioned above, usage of dereference variables may improve precision of the representation. This happens especially when we write into an abstract object through some pointer and afterwards read through the same pointer without changing its value nor the value of the pointed object in between. In such cases, we may reuse the same dereference variable which ensures that we get the same value that was written, which may not happen otherwise since we read from an abstract object representing a number of concrete objects.

4.3 Structural Transformations

The *kIkI* algorithm uses loop unwinding to refine the control flow structure of the program. There are several possible strategies of how to perform this unwinding. We have experimented in CBMC [35] with an unwinding strategy that follows the control flow and unwinds loops one by one and performs property checking after each unwinding. With such a strategy, each loop is incrementally unwound until all paths exit the loop or until a maximum depth k is reached. We can detect that a loop is fully unwound at unwinding $j < k$ if every state reached at unwinding j does not satisfy the loop condition. After a loop has been unwound, CBMC continues to the next loop. This procedure is repeated until all loops have been unwound or a bug has been found. Recursive function calls are treated similarly.

Consider the control flow graph (CFG) in Fig. 10(a). The unwinding strategy is illustrated for this CFG in Fig. 10(b). The program has three loops with loop heads 1, 2, and 6 (2 is nested inside 1). The symbolic execution that generates the incremental BMC formula $\Phi(k)$ (see Section 5.2) traverses the CFG and stops each time when it encounters an edge in the CFG that returns to a loop head (a so-called *back-edge*). Fig. 10(b) shows three snapshots of the partially unwound CFG that correspond to the parts of the program considered by instances of the incremental BMC formula $\Phi(k)$ for $k = 1, 2, m$. We write $\Phi(1)$ for the formula up to the first back-edge encountered that returns to the loop head of the inner loop (2). Formula $\Phi(2)$ extends $\Phi(1)$ by one further unwinding of the inner loop. Assume that m is the maximum number of unwindings of the inner loop, then $\Phi(m)$ shows the extension of the formula to the case where the inner loop has been unwound up to this maximum number within the first iteration of the outer loop (with loop head 1). Formula $\Phi(m + 1)$ will then extend $\Phi(m)$ by a first unwinding of the inner loop (up to program location 4) for the second iteration of the outer loop. This process continues until a failed assertion or the end of the program (8) is reached.

We realised that this approach is not very efficient. Hence, we implement a different approach in 2LS [34, 4]. 2LS unwinds *all* loops k times and incrementally adds the $(k + 1)$ th for *all* loops instead of unwinding only the first loop encountered until it has been fully unwound.

We illustrate this unwinding strategy in Fig. 10(c), which shows the first two partial unwindings of the CFG in Fig. 10(a) that correspond to $\Phi(1)$ and $\Phi(2)$, respectively. Formula $\Phi(1)$ consists of one unwinding (up to, but not including the back-edge) for the loops 1, 2, and 6. Formula $\Phi(2)$ then adds another unwinding to each loop. Note that we have two times two unwindings of the inner loop (with loop head 2) now, two for each unwinding of the outer loop (loop head 1).

Structurally, this unwinding strategy is the same as the one that we use in non-incremental CBMC when calling it with fixed values for k .

2LS performs loop unwinding on the SSA form augmented with some meta-information on the loop structure and hierarchy. The unwinding that we perform is incremental, in the sense that we incrementally extend the SSA when increasing k to $k + 1$. The problematic part is the merging of loop exits (nodes 5, 6, and 8 in Fig. 10(c)). We have to account for the case of “value is merged from an unwinding

that has not been added yet”, which makes the construction of the formula non-monotonic. Indeed, one has to effectively *remove* the disjunction describing each such merge, which represents one conjunct in the SSA form, and replace it by a larger disjunction reflecting the addition of a new incoming branch of the concerned merge obtained by an additional unwinding. Removing parts of the formula, however, is not supported by SAT solvers. Fortunately, this problem can be solved with the help of *solving under assumptions* as we will explain in Section 5.4. This is an essential ingredient for performance as it enables the use of a *single* SAT solver instance to run incremental BMC and ultimately the entire *kikI* algorithm.

A disadvantage of the approach is that many optimisations that can be typically done during symbolic execution in order to simplify the formula, such as constant propagation, can only be done locally, if at all.

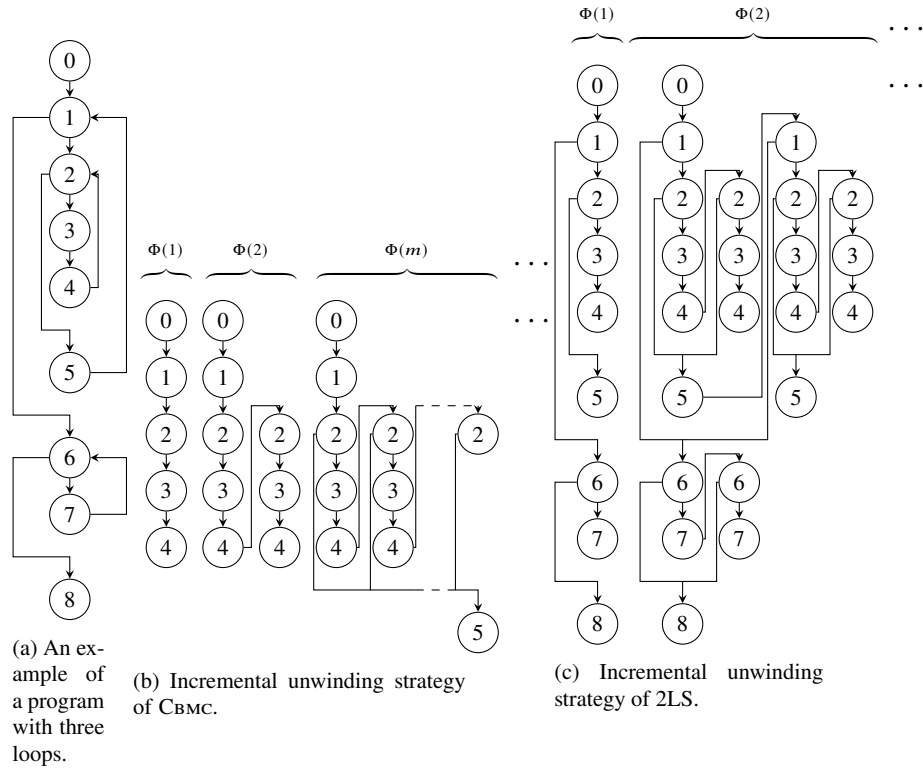

Fig. 10: Incremental unwinding strategies.

5 The k/kI algorithm

As we outlined in Section 2, the core of 2LS is the k/kI algorithm, which we present in detail in this section. The general workflow of the algorithm is shown in Figure 11. Initially, $k = 1$ and \mathcal{I} is a set of predicates that can be used as invariant with $\top \in \mathcal{I}$ (see Section 5.1 for details of how this is implemented).

After an initial test to see if any start states are errors, k/kI computes a k -inductive invariant that covers the initial state and includes the assumption that there are no errors in earlier states. The invariant is then checked to see whether it is sufficient to show safety. If there are possible reachable error states then a second check is needed to see if the error is reachable in k steps (a genuine counterexample) or whether it is a potential artefact of a too weak invariant. In the latter case, k is incremented so that a stronger (k -)invariant can be found and the algorithm loops.

Also displayed in Figure 11 are the steps of incremental BMC, k -induction and classical over-approximating abstract interpretation, given, respectively by the red dotted, blue dashed, and green dashed/dotted boxes and arrows. k/kI can simulate k -induction by having $\mathcal{I} = \{\top\}$ and incremental BMC by over-approximating the first SAT check. Classical over-approximate abstract interpretation can be simulated by having $\mathcal{I} = \mathcal{A}$ for an abstract domain \mathcal{A} and terminating with the result “unknown” if the first SAT check finds a model.

5.1 Template-Based Predicate Inference

A key phase of $kIkI$ is the generation of $KInv$, a k -inductive invariant. Perhaps the most obvious approach is to use an off-the-shelf abstract interpreter. This works but will fail to exploit the real power of $kIkI$. In each iteration, $kIkI$ unrolls loops one more step (which can improve the invariant given by an abstract interpreter) and adds assumptions that previous unwindings do not give errors.

When directly using a solver, we would need to handle (the existential fragment of) second-order logic. As such solvers are not currently available, we reduce to a problem that can be solved by iterative application of a first-order solver. We restrict ourselves to finding k -inductive invariants $KInv$ of the form $\mathcal{T}(\mathbf{x}, \delta)$ where \mathcal{T} is a fixed expression, a so-called *template*, over program variables \mathbf{x} and template parameters δ .

$$\begin{aligned} \exists \delta. \forall \mathbf{x}_0 \dots \mathbf{x}_k. & (Init(\mathbf{x}_0) \wedge T[k-1] \Rightarrow \mathcal{T}[k](\delta)) \wedge \\ & (\mathcal{T}[k](\delta) \wedge T[k] \Rightarrow \mathcal{T}(\mathbf{x}_k, \delta)) \end{aligned} \quad (9)$$

where $T[k]$ is the k -th unwinding of the transition relation and $\mathcal{T}[k]$ is a template for all states along the unwinding except for the last state \mathbf{x}_k :

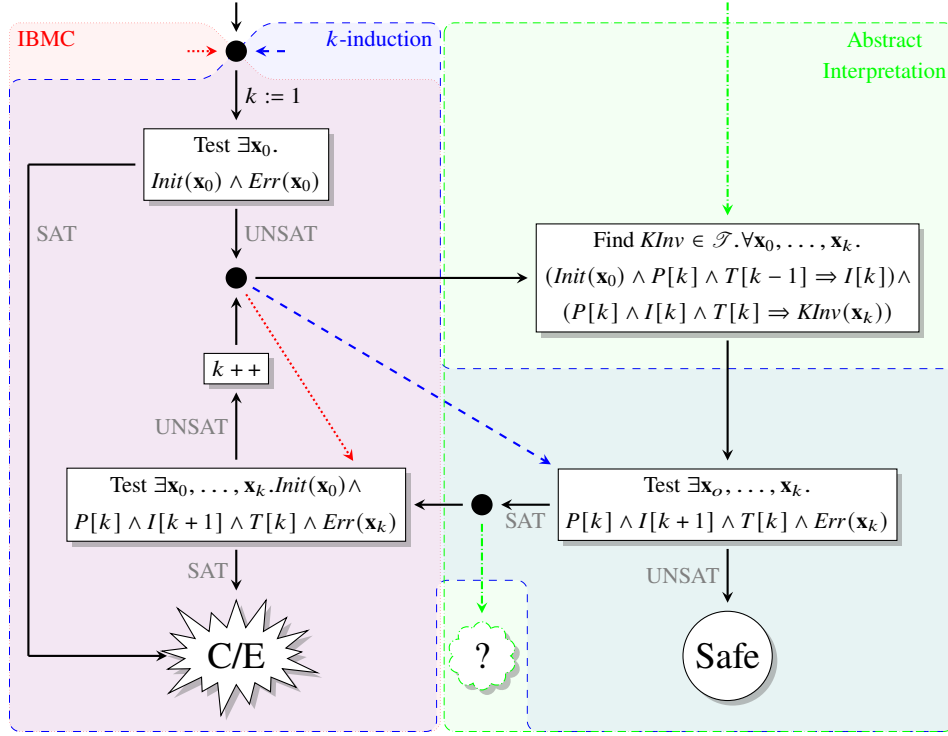
Fig. 11: The $kIKI$ algorithm.

$$T[k] = \bigwedge_{i \in [0, k-1]} \text{Trans}(\mathbf{x}_i, \mathbf{x}_{i+1}) \quad (10)$$

$$\mathcal{T}[k](\boldsymbol{\delta}) = \bigwedge_{i \in [0, k-1]} \mathcal{T}(\mathbf{x}_i, \boldsymbol{\delta}). \quad (11)$$

We resolve the $\exists\forall$ problem by an iterative solving of the negated formula, particularly of the second conjunct of (9), for different choices of constants \mathbf{d} as the values of the parameter $\boldsymbol{\delta}$:

$$\exists \mathbf{x}_0 \dots \mathbf{x}_k. \neg (\mathcal{T}[k](\mathbf{d}) \wedge T[k] \Rightarrow \mathcal{T}(\mathbf{x}_k, \mathbf{d})). \quad (12)$$

The resulting formula can be expressed in quantifier-free logics and efficiently solved by SMT solvers. Using this as a building block, one can solve the mentioned $\exists\forall$ problem.

From the abstract interpretation point of view, \mathbf{d} is an abstract value, i.e. it represents (*concretises to*) the set of all program states \mathbf{s} —here, a state is a vector of values of variables from \mathbf{x} —that satisfy the formula $\mathcal{T}(\mathbf{s}, \mathbf{d})$. The abstract values representing the infimum \perp and supremum \top of the abstract domain denote the empty set and the whole state space, respectively: $\mathcal{T}(\mathbf{s}, \perp) \equiv \text{false}$ and $\mathcal{T}(\mathbf{s}, \top) \equiv \text{true}$ [4].

Formally, the concretisation function γ is: $\gamma(\mathbf{d}) = \{\mathbf{s} \mid \mathcal{T}(\mathbf{s}, \mathbf{d}) \equiv \text{true}\}$. In the abstraction function, to get the most precise abstract value representing the given concrete program state \mathbf{s} , we let $\alpha(\mathbf{s}) = \{\min(\mathbf{d}) \mid \mathcal{T}(\mathbf{s}, \mathbf{d}) \equiv \text{true}\}$. If the abstract domain forms a complete lattice, existence of such a minimal value \mathbf{d} is guaranteed.

The algorithm for the invariant inference takes an initial value of $\mathbf{d} = \perp$ and iteratively solves (12) using an SMT solver. If the formula is unsatisfiable, then an invariant has been found, otherwise a model of satisfiability \mathbf{d}' is returned by the solver. The model represents a counterexample to the current instantiation of the template being an invariant. The value of the template parameter \mathbf{d} is then updated by combining the current value with the obtained model of satisfiability using a domain-specific join operator [4].

For example, assume we have a program with a loop that counts from 0 to 10 in variable x , and we have a template $x \leq d$. Let us assume that the current value of the parameter d is 3, and we get a new model $d' = 4$. Then we update the parameter to 4 by computing $d \sqcup d' = \max(d, d')$, because \max is the join operator for a domain that tracks numerical upper bounds.

In 2LS, we use a single template to compute all invariants of the analysed program. Therefore, typically, a template is composed of multiple parts, each part describing an invariant for a set of program variables. With respect to this, we expect a template $\mathcal{T}(\mathbf{x}, \delta)$ to be composed of so-called *template rows* $\mathcal{T}_r(\mathbf{x}_r, \delta_r)$, each row r describing an invariant for a subset \mathbf{x}_r of variables \mathbf{x} and having its own row parameter δ_r . The overall invariant is then a composition of individual template rows with computed values of the corresponding row parameters. The kind of the composition (it can be, e.g., a simple conjunction) is defined by each domain.

5.1.1 Guarded Templates

Since we use the SSA form rather than control flow graphs, we cannot use templates directly. Instead we use *guarded templates*. As described above, a template is composed of multiple template rows, each row describing an invariant for a subset of program variables. In a guarded template, each row r is of the form $G_r(\mathbf{x}_r) \Rightarrow \widehat{\mathcal{T}}_r(\mathbf{x}_r, \delta_r)$ for the r^{th} row $\widehat{\mathcal{T}}_r$ of the base template domain (e.g. template polyhedra). G_r is the conjunction of the SSA guards g_r associated with the definition of variables \mathbf{x}_r occurring in $\widehat{\mathcal{T}}_r$. Since we intend to infer loop invariants, $G_r(\mathbf{x}_r)$ denotes the guard associated to variables \mathbf{x}_r appearing at the loop head. Hence, template rows for different loops have different guards.

We illustrate the above on the example program in Figure 9 using a guarded interval template. The template has the form:

$$\mathcal{T}(x_6^{lb}, (\delta_1, \delta_2)) = \begin{aligned} &g_3 \wedge g_6^{ls} \Rightarrow x_6^{lb} \leq \delta_1 \wedge \\ &g_3 \wedge g_6^{ls} \Rightarrow -x_6^{lb} \leq \delta_2. \end{aligned} \quad (13)$$

Here, g_3 and g_6^{ls} guard the definition of x_6^{lb} — g_3 expresses the fact that the loop head is reachable and g_6^{ls} expresses that x_6^{lb} is chosen as the value of x_3^{phi} .

5.1.2 Solving of the $\exists\forall$ Problem

As discussed above, it is necessary to solve an $\exists\forall$ problem to find values for template parameters δ to infer invariants.

Model enumeration

The well-known method [31, 5] for solving this problem in (12) using an SMT solver is to repeatedly check satisfiability of the formula for different abstract values \mathbf{d} (starting with the infimum $\mathbf{d} = \perp$):

$$\mathcal{T}[k](\mathbf{d}) \wedge T[k] \wedge \neg\mathcal{T}(\mathbf{x}_k, \mathbf{d}). \quad (14)$$

If it is unsatisfiable, then we have found an invariant; otherwise, we join the model returned by the solver with the previous abstract value \mathbf{d} and repeat the process with the new value of \mathbf{d} obtained from the join.

This method corresponds to performing a classical Kleene iteration on the abstract lattice up to convergence. Convergence is guaranteed because our abstract domains are finite. However, while this method might be sufficient for some abstract domains (especially those with a low number of possible states), it is practically unusable for other ones. For example, when dealing with integer variables, the height of the lattice is enormous and even for a one-loop program incrementing an unconstrained 64-bit variable, the naïve algorithm will not terminate within human life time. Hence, for some abstract domains, we are going to use an optimised method (e.g., for some numerical domains, see Section 6.1).

In general, there may be a specific method for solving the $\exists\forall$ problem for each domain. We refer to these methods as to *domain strategy iterations*.

Generic domain strategy iteration

Even though each domain may implement its own strategy iteration algorithm, we observe that all algorithms are to some extent similar. This is related to the fact that abstract domain templates are typically composed of multiple template rows, as described earlier in this section.

With respect to this, we developed a *generic strategy iteration* algorithm [26] parametrised by an abstract domain having the form of a template. The algorithm is shown in Figure 12.

The algorithm repeatedly solves (14) for the given abstract domain. If the formula is satisfiable, then for each template row r , the algorithm gets the model of satisfiability for the variables that r describes. The obtained model (i.e., the values of the concerned variables) is used to instantiate the template row formula (line 8) and the corresponding value of the template parameter is joined with the previous value of the row parameter.

```

1:  $\mathbf{d} \leftarrow \perp$ 
2: while  $\mathcal{T}[k](\mathbf{d})$  is not an invariant do
3:   solver  $\leftarrow \mathcal{T}[k](\mathbf{d})$ 
4:   solver  $\leftarrow \neg\mathcal{T}(\mathbf{x}_k, \mathbf{d})$ 
5:   if solver.solve() = SAT then
6:     for  $\mathcal{T}_r(\mathbf{x}_r, d_r) \in \mathcal{T}(\mathbf{x}, \mathbf{d})$  do
7:        $m_r \leftarrow$  solver.model( $\mathbf{x}_r$ )
8:       find  $d_m$  s.t.  $\mathcal{T}_r(m_r, d_m)$  holds
9:        $d_r \leftarrow d_r \sqcup d_m$ 
10:    end for
11:  end if
12: end while

```

Fig. 12: Generic strategy iteration algorithm for solving the $\exists\forall$ problem.

Since 2LS uses incremental solving, we assume that the transition relation (expressed by the SSA form) is already a part of the solver clause set. Moreover, formulae added to the solver clause set on lines 3 and 4 are removed after each iteration. This ensures efficiency of the method since only the new formulae need to be re-solved every time.

However, as we mentioned in the previous section, an optimisation may be required in order to assure scaling of the algorithm. In such case, lines 7-9 are replaced by the optimised method for determining values of template row parameters. We will give an example for such optimised techniques in Section 6.1.

5.2 Incremental Bounded Model Checking

Bounded Model Checking (BMC) [2] focuses on refutation by picking an *unwinding limit* k and solving the equation

$$\exists \mathbf{x}_0, \dots, \mathbf{x}_k. \text{Init}(\mathbf{x}_0) \wedge T[k] \wedge \neg P[k+1] \quad (15)$$

where $T[k]$ is an unwound transition relation as defined by (10) and $P[k]$ is a predicate stating that k states are error-free:

$$P[k] = \bigwedge_{i \in [0, k-1]} \neg \text{Err}(\mathbf{x}_i). \quad (16)$$

Models of (15) correspond to concrete counterexamples of some length $n \leq k$. The unwinding limit gives an *under-approximation* of the set of reachable states and thus can fail to find counterexamples that take a large number of transition steps. In practice, BMC works well as the formula is existentially quantified and thus is in a fragment handled well by SAT and SMT solvers.

Incremental bounded model checking is one of the core components of the $kIKI$ algorithm presented in Section 5. It corresponds to the red part in Figure 11. In-

cremental BMC (IBMC) (e.g. [13]) uses repeated BMC checks (often optimised by using the solver incrementally) with increasing bounds to avoid the need for a fixed bound. If the bound starts at 0 (i.e. checking $\exists x_0. \text{Init}(\mathbf{x}_0) \wedge \text{Err}(\mathbf{x}_0)$) and is increased by one in each step (this is the common use-case), then it can be assumed that there are no errors at previous states, giving a simpler test:

$$\exists \mathbf{x}_0, \dots, \mathbf{x}_k. \text{Init}(\mathbf{x}_0) \wedge T[k] \wedge P[k] \wedge \text{Err}(\mathbf{x}_k). \quad (17)$$

In Section 5.4, we will discuss how incremental BMC can be implemented efficiently using incremental SAT solving.

5.3 Incremental k -Induction

Incremental k -induction [36] is the blue part of the $kIkI$ algorithm in Figure 11. It can be viewed as an extension of IBMC that can show system safety as well as produce counterexamples. It makes use of *k -inductive invariants*, which are predicates that have the following property:

$$\forall \mathbf{x}_0 \dots \mathbf{x}_k. I[k] \wedge T[k] \Rightarrow \text{KInv}(\mathbf{x}_k) \quad (18)$$

where

$$I[k] = \bigwedge_{i \in [0, k-1]} \text{KInv}(\mathbf{x}_i).$$

k -inductive invariants have the following useful properties:

- Any inductive invariant is a 1-inductive invariant and vice versa.
- Any k -inductive invariant is a $(k + 1)$ -inductive invariant.
- A (finite) system is safe if and only if there is a k -inductive invariant KInv which satisfies:

$$\begin{aligned} \forall \mathbf{x}_0 \dots \mathbf{x}_k. & (\text{Init}(\mathbf{x}_0) \wedge T[k] \Rightarrow I[k]) \wedge \\ & (I[k] \wedge T[k] \Rightarrow \text{KInv}(\mathbf{x}_k)) \wedge \\ & (\text{KInv}(\mathbf{x}_k) \Rightarrow \neg \text{Err}(\mathbf{x}_k)). \end{aligned} \quad (19)$$

Showing that a k -inductive invariant exists is sufficient to show that an inductive invariant exists *but it does not imply that the k -inductive invariant is an inductive invariant*. Often the corresponding inductive invariant is significantly more complex. Thus k -induction can be seen as a trade-off between invariant *generation* and *checking* as it is a means to benefit as much as possible from simpler invariants by using a more complex property check.

However, finding a candidate k -inductive invariant is still hard, and so implementations often use $\neg \text{Err}(\mathbf{x})$ as the candidate. Similarly to IBMC, linearly increasing k can be used to simplify the expression by assuming there are no errors at previous states:

$$\begin{aligned} \exists \mathbf{x}_0, \dots, \mathbf{x}_k. & (\text{Init}(\mathbf{x}_0) \wedge T[k] \wedge P[k] \wedge \text{Err}(\mathbf{x}_k)) \vee \\ & (T[k] \wedge P[k] \wedge \text{Err}(\mathbf{x}_k)). \end{aligned} \quad (20)$$

A model of the first part of the disjunct is a concrete counterexample (k -induction subsumes IBMC) and if the whole formula has no models, then $\neg Err(\mathbf{x})$ is a k -inductive invariant and the system is safe.

5.4 Incremental SAT Solving

2LS requires incremental back-end solvers. The first ideas for incremental SAT solving date back to the 1990s [19, 37, 20]. The question is how to solve a sequence of similar SAT problems while reusing the effort spent on solving previous instances. The authors of [38, 39] identify conditions for the reuse of learnt clauses, but this requires expensive book-keeping, which partially saps the benefit of incrementality. Obviously, incremental SAT solving is easy when the modification to the CNF representation of the problem makes it grow monotonically. This means that if we want to solve a sequence of (increasingly constrained) SAT problems with CNF formulae $\Phi(k)$ for $k \geq 0$, then $\Phi(k)$ must be *growing monotonically* in k , i.e., $\Phi(k+1) = \Phi(k) \wedge \varphi(k)$ for CNF formulae $\varphi(k)$. Removal of clauses from $\Phi(k)$ is trickier as some of the clauses learnt during the solving process are no longer implied by the new instance and need to be removed as well. This requires additional solver features like solving *under assumptions* [13], which is the most popular approach to incremental SAT solving: assumptions are temporary assignments to variables that hold solely for one specific invocation of the SAT solver. We will see that incremental BMC requires a *non-monotonic* series of formulae.

An alternative approach is to use SMT solvers. SMT solvers offer an interface for pushing and popping clauses in a stack-like manner. Pushing adds clauses, popping removes them from the formula. This makes the modification of the formula intuitive to the user, but the efficiency depends on the underlying implementation of the push and pop operations. For example, in [17], it was observed that some SMT solvers (like Z3) are not optimised for incremental usage and hence perform worse incrementally than non-incrementally.

Consequently, since the support for incremental solving in SMT solvers is still lagging behind in comparison to SAT solvers, we use SAT solving. The CPROVER framework [8] itself implements powerful bitvector decision procedures that use a SAT solver such as MINISAT2 [12] or Glucose⁴ as the backend solver. For SAT solvers, solving under assumptions is the prevalent method.

Formula construction in incremental BMC

Following the construction in [13] (stated for finite state machines), incremental BMC can be formulated as a sequence of SAT problems $\Phi(k)$ that we need to solve:

⁴ <http://www.labri.fr/perso/lsimon/glucose/#glucose-4.0>

$$\begin{aligned}
\Phi(0) &:= \text{Init}(\mathbf{x}_0) \wedge (\alpha_0 \Rightarrow \text{Err}(\mathbf{x}_0)) \\
&\quad \text{with the assumption } \alpha_0, \\
\Phi(k+1) &:= \Phi(k) \wedge \neg \text{Err}(\mathbf{x}_k) \wedge \text{Trans}(\mathbf{x}_k, \mathbf{x}_{k+1}) \wedge \neg \alpha_k \wedge (\alpha_{k+1} \Rightarrow \text{Err}(\mathbf{x}_{k+1})) \\
&\quad \text{with the assumption } \alpha_{k+1}
\end{aligned} \tag{21}$$

where α_k are Boolean variables. Let us now take a look why these are necessary. Consider a program counting in variable x from 0 to 10. There is an assertion inside the loop that $x \leq 1$ is expected to hold. We start with the initial formula (omitting Boolean variables α_k):

$$\Phi(0) := (x_0=0) \wedge (x_0 < 10) \wedge (x_1=x_0+1) \wedge \neg(x_1 \leq 1).$$

This formula is UNSAT. We now (naïvely) extend the formula with the next loop iteration:

$$\Phi(1) := (x_0=0) \wedge (x_0 < 10) \wedge (x_1=x_0+1) \wedge \neg(x_1 \leq 1) \wedge (x_1 < 10) \wedge (x_2=x_1+1) \wedge \neg(x_2 \leq 1).$$

This is still UNSAT, although we expect it to be SAT. Obviously, the reason is that we are adding further conjuncts to something that is already UNSAT. Therefore, in order to be sound, we have to remove $x_1 > 1$ from the previous iteration, which makes the formula construction non-monotonic.

However, as explained above, we cannot simply remove parts of the formula from the solver, but we can solve this issue with the help of *solving under assumptions*. In iteration k , the assumption α_k is assumed to be true, whereas it is assumed false for iterations $k' > k$. This has the effect that, in iteration k' , the sub-formula $(\alpha_k \Rightarrow \text{Err}(\mathbf{x}_k))$ becomes trivially satisfied. Hence, it does not contribute to the (un)satisfiability of $\Phi(k')$, which emulates its deletion.⁵

The Benefit of Incremental BMC

Non-incremental BMC has to perform extra work in symbolic execution for each unwinding k . As investigated in [35], one might argue that removing this overhead is the main reason why incremental BMC is faster. However, the overhead for symbolic execution when compared to generating and solving a SAT formula is similar for the incremental and non-incremental approach: on the embedded software benchmark set of [35], 27 % of the time taken by the incremental approach are spent in solving SAT formulae (582 out of 2,151 seconds), compared with 28 % of the time taken by the non-incremental approach (3,317 out of 11,811 seconds). We illustrate this observation in the bar chart in Fig. 13, which plots the total runtime consisting of the time spent in generating SAT formulae and solving them (light grey) and the overhead (dark grey) for incremental and non-incremental BMC. Unsurprisingly, as shown in the third bar in Fig. 13, solving the instance for the largest k in the non-

⁵ For a large number of iterations k , such trivially satisfied subformulas might accumulate as “garbage” in the formula and slow down its resolution. Restarting the solver at appropriate moments is the common solution to this issue [6].

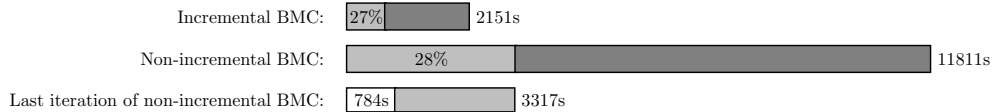

Fig. 13: The benefit of incremental BMC: solving time vs. overall runtime (explanation in the text).

incremental approach (white) takes a considerable amount of time (around 24%), when compared to the total time (white+grey) for solving the SAT formulae for iterations 1 to k (784 out of 3,317 seconds).

An explanation for the speedups achieved by incremental BMC might be the size of the queries issued in both approaches. The average number of clauses per solver call is halved from 1,367k clauses for the non-incremental approach to 709k clauses for the incremental approach. Similarly, the average number of variables of the last call is less than a third in the incremental approach when compared to the non-incremental approach, being 217k and 746k respectively. That means that the SAT solver is able to simplify the formulae within pre-processing much more efficiently in the incremental approach.

The work [35] experimented with an incremental slicing algorithm in combination with incremental unwinding in CBMC; however, this is not implemented in 2LS. The work [30] developed an SMT solving algorithm in 2LS (which is available in a prototype branch of 2LS) that uses template polyhedra instead of Boolean literals in order to perform theory-level propagation based on the concept of Abstract Conflict Driven Learning [11].

6 Implemented Analyses

2LS supports analysis of various program features such as reachability of assertions, termination, or memory safety. For most of these analyses, 2LS introduces abstract domains [10] for invariant inference, which is one of the steps of the $kIKI$ algorithm.

There are numerical domains such as template polyhedra (see Section 6.1), equalities and disequalities, domains for ranking functions (see Section 6.2) and recurrent sets (see Section 6.3), and domains for the shape of data structures (see Section 6.4).

In this section, we introduce the most important supported abstract domains as well as other concepts that support verification of various program properties.

6.1 Template Polyhedra Abstract Domain

Template polyhedra [32] are a class of templates for numerical variables which have the form $\mathcal{T} = (\mathbf{Ax} \leq \boldsymbol{\delta})$ where \mathbf{A} is a matrix with fixed coefficients. Subclasses of such templates include *Intervals*, which require constraints $\begin{pmatrix} 1 \\ -1 \end{pmatrix} x_i \leq \begin{pmatrix} \delta_{i1} \\ \delta_{i2} \end{pmatrix}$ for each variable x_i , *Zones* (differences), and *Octagons* [28]. The r^{th} row of the template are the constraints generated by the r^{th} row of matrix \mathbf{A} .

In our template expressions, variables \mathbf{x} are *bit-vectors* representing signed or unsigned integers. These variables can be mixed in template constraints. Type promotion rules are applied such that the bit-width of the types of the expressions are extended in order to avoid arithmetic under- and overflows in the template expressions. \top corresponds to the respective maximum values in the promoted type, whereas \perp must be encoded as a special symbol.

Optimised Solving of the $\exists\forall$ Problem

In order to solve the parameter synthesis problem efficiently, we need a convergence acceleration that makes the computational effort *independent* from the number of states and loop iterations. To this end, we use a technique that is inspired by an encoding used by *max-strategy iteration* methods [15, 14, 29]. These methods state the invariant inference problem over template polyhedra as a disjunctive linear optimisation problem, which is solved iteratively by an upward iteration in the lattice of template polyhedra: using SMT solving, a conjunctive subsystem (“strategy”) whose solution extends the current invariant candidate is selected. This subsystem is then solved by an LP solver; the procedure terminates as soon as an inductive invariant is found.⁶

The above method can only be used if the domain is convex and the parameter values are ordered and monotonic w.r.t. concretisation, which holds true, for example, for template polyhedra $\mathbf{Ax} \leq \mathbf{d}$ where \mathbf{d} is a parameter but not for those where \mathbf{A} is a parameter. If the operations in the transition relation satisfy certain properties such as monotonicity of condition predicates, then the obtained result is the least fixed

⁶ Intuitively, this works as follows: As an example, assume the domain of upper bounds on numerical variables (but the approach extends to any domain satisfying the conditions mentioned further below). An invariant upper bound at a program location is then the maximum value contributed by any of the incoming transitions to the program location. Writing this down as an optimisation problem over a system of linear inequalities, incoming transitions form disjunctions. Considering multiple program locations we get conjunctions of these disjunctions. So, we have a linear system in the CNF form. This can be solved by finding those disjuncts (i.e., incoming transitions) in each clause that are satisfied by the initial state (there must be such, otherwise the system is not feasible). We can then pick these disjuncts and conjoin them (as the “strategy”), resulting in a (conjunctive) linear system (called a conjunctive subsystem), which can be solved using an LP solver. The obtained upper bound is only valid for those disjuncts that have been picked. If it is not an invariant yet, then there must be disjuncts that can be substituted for some of the disjuncts to improve the bound. This can be repeated and is guaranteed to terminate with the minimal invariant.

point, i.e. the *same* result as the one returned by the naïve model enumeration above but much faster on average.

We adapt this method to our setting with bit-vector variables and guarded templates. Since we deal with finite domains (bit-vectors), we can use *binary search* as an optimisation method instead of an LP solver.

The algorithm proceeds as follows: We start by checking whether the current abstract value \mathbf{d} (starting from $\mathbf{d} = \perp$) is inductive (see (14)). If so, we have found an invariant; otherwise there are template rows R whose values are not inductive yet. Moreover, the counterexample to induction obtained from the inductivity check tells us which bounds need to be improved. We construct the system

$$\bigwedge_{i \in [0, k-1]} \left\{ \begin{array}{l} \bigwedge_{r \notin R} G_r(\mathbf{x}_i) \Rightarrow (e_r(\mathbf{x}_i) \leq d_r) \\ \bigwedge_{r \in R} G_r(\mathbf{x}_i) \Rightarrow (e_r(\mathbf{x}_i) \leq \delta_r) \end{array} \right\} \wedge T[k] \wedge \bigwedge_{r \in R} (G_r(\mathbf{x}_k) \wedge \delta_r \leq e_r(\mathbf{x}_k)) \quad (22)$$

where e_r is the left-hand side of the inequality corresponding to the r^{th} row of the template. Then we start the binary search for the minimal value of $\sum_{r \in R} \delta_r$ over this system. The initial bounds for $\sum_{r \in R} \delta_r$ are as follows:

- The lower bound ℓ is $\sum_{r \in R} d'_r$ where d'_r is the value of $e_r(\mathbf{x}_k)$ in the model of the inductivity check (14) above;
- The upper bound u is $\sum_{r \in R} \text{max_value}(r)$ where max_value returns the maximum value that $e_r(\mathbf{x}_k)$ may have (dependent on variable type).

The binary search is performed by iteratively checking (22) for satisfiability under the assumption $\sum_{r \in R} \delta_r \geq m$ where $m = \text{median}(\ell, u)$. If satisfiable, set $\ell := m$, otherwise set $u := m$ and repeat until $\ell = u$. The values of δ_r in the last satisfiable query are assigned to d_r to obtain the new abstract value. The procedure is then repeated by testing whether \mathbf{d} is inductive (14). Note that this algorithm uses a similar encoding for bound optimisation as strategy iteration, but it potentially requires a higher number of iterations than strategy iteration. This choice has been made deliberately in order to keep the size of the generated SMT formulas small, at the cost of a potentially increased number of iterations. The same row r may be removed from R and improved again in later iterations. However, as each iteration makes progress, the algorithm terminates in a finite number of iterations.

We illustrate the binary search algorithm on the example from Figure 9. We use the interval abstract domain to compute the interval for the value of the variable x at the end of the loop. We let $k = 1$, and therefore we let $\mathbf{x}_0 = (x_6^{lb})$ and $\mathbf{x}_1 = (x_5)$.⁷ The corresponding guarded template \mathcal{T} has the form defined in (13). The template contains two template rows defined as:

$$G_0(x_6^{lb}) \Rightarrow x_6^{lb} \leq \delta_0 \quad (23)$$

$$G_1(x_6^{lb}) \Rightarrow -x_6^{lb} \leq \delta_1 \quad (24)$$

⁷ Variables \mathbf{x}_0 apply to the case of zero iterations of the loop, hence unconstrained x_6^{lb} is taken here as the value of x .

where $G_0(x_6^{lb}) = G_1(x_6^{lb}) = g_3 \wedge g_6^{ls}$. We also define the template row guards for variables \mathbf{x}_1 (corresponding to the values of the program variables after one execution of the transition relation) as $G'_0(x_5) = G'_1(x_5) = g_5 = x_3^{phi} < 10$.

Initially, $\mathbf{d} = \perp$, and we solve (14). Since using $\mathbf{d} = \perp$ as the value of the parameters makes the instance of the template *false* by definition, the invariant cannot be inductive, and we get a model of satisfiability. Neither of the template rows is inductive, and hence we instantiate (22) with $R = \{0, 1\}$. The obtained system of formulae is the following (with $Trans(\mathbf{x}_0, \mathbf{x}_1)$ being the conjunction of the constraints shown in Fig. 9(b)):

$$\begin{aligned}
G_0(x_6^{lb}) &\Rightarrow x_6^{lb} \leq \delta_0 \wedge \\
G_1(x_6^{lb}) &\Rightarrow -x_6^{lb} \leq \delta_1 \wedge \\
&Trans(\mathbf{x}_0, \mathbf{x}_1) \wedge \\
G'_0(x_5) &\wedge \delta_0 \leq x_5 \wedge \\
G'_1(x_5) &\wedge \delta_1 \leq -x_5.
\end{aligned} \tag{25}$$

We apply binary search to the system starting with $\ell = -2^{31}$ and $u = 2^{31} - 1$. We get $\delta_0 = 1$ and $\delta_1 = -1$. Now, template row 1 ($-x_6^{lb} \leq -1$) is inductive, however, template row 0 is not inductive. We construct a new system as per (22) with $R = \{0\}$:

$$\begin{aligned}
G_0(x_6^{lb}) &\Rightarrow x_6^{lb} \leq \delta_0 \wedge \\
G_1(x_6^{lb}) &\Rightarrow -x_6^{lb} \leq -1 \wedge \\
&Trans(\mathbf{x}_0, \mathbf{x}_1) \wedge \\
G'_0(x_5) &\wedge (\delta_0 \leq x_5).
\end{aligned} \tag{26}$$

Using binary search, we get $\delta_0 = 10$. With this, template row 0 is inductive, and so we have found an invariant, namely:

$$\begin{aligned}
g_3 \wedge g_6^{ls} &\Rightarrow x_6^{lb} \leq 10 \wedge \\
g_3 \wedge g_6^{ls} &\Rightarrow -x_6^{lb} \leq -1.
\end{aligned} \tag{27}$$

Bitvector Width Extension

Integers wrap around on most architectures when they over/underflow. Thus, we have to be mindful of these in arithmetic within templates in order to guarantee soundness of the results.

Let us consider an example of analysing termination of the following function by synthesising a ranking function.

```

void f() {
    signed char x;
    while(1) x++;
}

```

The ranking function synthesis aims to compute a value for a template parameter ℓ such that $\ell(x-x') > 0$ holds for all x, x' under the transition relation $x'=x+1$ and the computed invariant *true*.

Thus, assuming that the current value for ℓ is -1 , the constraint to be solved is

$$\text{true} \wedge x'=x+1 \wedge \neg(-1 \cdot (x-x') > 0),$$

which is equivalent to $\neg(-1(x-(x+1)) > 0)$. While for mathematical integers this is satisfiable, it is unsatisfiable for signed bit-vectors due to overflows. For $x=127$, the overflow happens such that $x+1=-128$ if `signed char` is an 8-bit signed integer. Thus, $\neg(-1 \cdot (127-(-128)) > 0)$ becomes $\neg(1 > 0)$, which makes the constraint unsatisfiable, and we would incorrectly conclude that $-x$ is a ranking function, which does not hold for signed bitvector semantics. However, if we extend the bitvector width to $k=9$ such that the arithmetic in the template does not overflow, then $\neg(-1 \cdot ((\text{signed}_9)127 - (\text{signed}_9)(-128)) > 0)$ evaluates to $\neg((-1 \cdot 255) > 0)$, where signed_k is a cast to a k -bit signed integer. Now, $x=127$ is a model that shows that $-x$ is not a valid ranking function.

For these reasons to retain soundness, we extend the bit-width of signed and unsigned integer operands to integers that can hold the result of the operation without over- or underflow, e.g., one additional bit for additions and doubling the size plus one bit for multiplications. The maximum bit-width required depends on the shape of the template. Since our templates contain a finite number of operations, the maximum bit-width is finite.

Floating-point numbers do not require extensions as they overflow (resp. underflow) to infinity (resp. minus infinity), which does not impact soundness.

6.2 Termination Analysis

For reasoning about termination, we need the notions of ranking functions and preconditions for termination.

Definition 1 (Ranking function)

A *ranking function* for a procedure $(\text{Init}, \text{Trans})$ is a function r such that

$$\begin{aligned} &\exists \Delta > 0, \text{Inv} : \forall \mathbf{x}, \mathbf{x}' : \\ &\quad (\text{Init}(\mathbf{x}) \implies \text{Inv}(\mathbf{x})) \\ &\quad \wedge (\text{Inv}(\mathbf{x}) \wedge \text{Trans}(\mathbf{x}, \mathbf{x}') \implies \text{Inv}(\mathbf{x}') \wedge r(\mathbf{x}) - r(\mathbf{x}') > \Delta \wedge r(\mathbf{x}) > 0). \end{aligned}$$

Thus, r is a function from the set of program states to a well-founded domain, e.g. $\mathbb{R}^{\geq 0}$.

We denote by $RR(\mathbf{x}, \mathbf{x}')$ the constraints on r that form the *termination argument*, i.e., $r(\mathbf{x}) - r(\mathbf{x}') > \Delta \wedge r(\mathbf{x}) > 0$ for monolithic ranking functions. The existence of a ranking function for a procedure guarantees its *universal* termination.

Monolithic ranking functions are complete, i.e., termination can always be proven monolithically if a program terminates. However, in practice, combinations of linear ranking functions, e.g., linear lexicographic functions are preferred. This is driven by the fact that monolithic *linear* ranking functions are not expressive enough, and that *non-linear* theories are challenging for the existing SMT solvers, which handle the linear case much more efficiently.

Definition 2 (Lexicographic ranking function)

A *lexicographic ranking function* R for a procedure $(Init, Trans)$ is an n -tuple of expressions $(R_n, R_{n-1}, \dots, R_1)$ such that

$$\begin{aligned} & \exists \Delta > 0, Inv : \forall \mathbf{x}, \mathbf{x}' : \\ & (Init(\mathbf{x}) \implies Inv(\mathbf{x})) \\ & \wedge (Inv(\mathbf{x}) \wedge Trans(\mathbf{x}, \mathbf{x}') \implies Inv(\mathbf{x}') \wedge \exists i \in [1, n] : \\ & \quad R_i(\mathbf{x}) > 0 \quad \text{(Bounded)} \\ & \quad \wedge R_i(\mathbf{x}) - R_i(\mathbf{x}') > \Delta \quad \text{(Decreasing)} \\ & \quad \wedge \forall j > i : R_j(\mathbf{x}) - R_j(\mathbf{x}') \geq 0 \quad \text{(Non-increasing)} \end{aligned}$$

Notice that this is a special case of Definition 1. In particular, the existence of $\Delta > 0$ and the *Bounded* condition guarantee that $>$ is a well-founded relation.

Before we encode the requirements for lexicographic ranking functions into constraints, we need to optimise them to take advantage of bit-vector semantics. Since bit-vectors are bounded, it follows that the *Bounded* condition is trivially satisfied and therefore can be omitted. Moreover, bit-vectors are discrete, hence we can replace the *Decreasing* condition with $R_i(\mathbf{x}) - R_i(\mathbf{x}') > 0$. The following formula, LR^n , holds if and only if $(R_n, R_{n-1}, \dots, R_1)$ is a lexicographic ranking function with n components over bit-vectors.

$$LR^n(\mathbf{x}, \mathbf{x}') = \bigvee_{i=1}^n \left(R_i(\mathbf{x}) - R_i(\mathbf{x}') > 0 \wedge \bigwedge_{j=i+1}^n (R_j(\mathbf{x}) - R_j(\mathbf{x}') \geq 0) \right)$$

Assume we are given the transition relation $Trans(\mathbf{x}, \mathbf{x}')$ of a procedure f . The procedure f may be composed of several loops, and each of the loops is associated with guards g (and g') that express the reachability of the loop head (and the end of the loop body, respectively; see Section 4.2). That is, suppose f has k loops and n_i denotes the number of lexicographic components for loop i , then the termination argument to prove termination of f takes the form:

$$RR^n(\mathbf{x}, \mathbf{x}') = \bigwedge_{i=1}^k g_i \wedge g'_i \implies LR_i^{n_i}(\mathbf{x}, \mathbf{x}')$$

While ranking techniques for mathematical integers use, e.g., Farkas' Lemma, this is not applicable to bitvector operations. Thus, we use a synthesis approach and extend it from monolithic to lexicographic ranking functions.

We consider the class of lexicographic ranking functions generated by the template where $R_i(\mathbf{x})$ is the product $\ell_i \mathbf{x}$ with the row vector ℓ_i of template parameters. We denote the resulting constraints for loop i as $\mathcal{LR}_i^{n_i}(\mathbf{x}, \mathbf{x}', L_i^{n_i})$ where $L_i^{n_i}$ is the vector $(\ell_i^1, \dots, \ell_i^{n_i})$. The constraints for the ranking functions of a whole procedure are $\mathcal{RR}(\mathbf{x}, \mathbf{x}', \mathbf{L}^n)$, where \mathbf{L}^n is the vector $(L_1^{n_1}, \dots, L_k^{n_k})$.

Putting all this together, we obtain the following reduction of ranking function synthesis to a first-order quantifier elimination problem over templates:

$$\exists \mathbf{L}^n : \forall \mathbf{x}, \mathbf{x}' : Inv(\mathbf{x}) \wedge Trans(\mathbf{x}, \mathbf{x}') \implies \mathcal{RR}(\mathbf{x}, \mathbf{x}', \mathbf{L}^n)$$

The parameters $L_i^{n_i}$ are vectors of vectors of bitvectors extended by the special value \top in order to complete the lattice of ranking constraints $\mathcal{LR}_i^{n_i}$. We define $\mathcal{LR}_i^{n_i}(\mathbf{x}, \mathbf{x}', \top) \equiv true$ indicating that no ranking function has been found for the given template (“don’t know”). We write \perp for the equivalence class of bottom elements for which $\mathcal{LR}_i^{n_i}(\mathbf{x}, \mathbf{x}', L_i^{n_i})$ evaluates to *false*, meaning that the ranking function has not yet been computed. For example, $\mathbf{0}$ is a bottom element. Note that this intuitively corresponds to the meaning of \perp and \top as known from invariant inference by abstract interpretation (see Section 5.1).

The algorithms for solving these formulae are described in detail in [7]. Moreover, [7] explains algorithms for conditional termination, i.e. programs that terminate only when certain conditions on their inputs hold. The objective is to determine these conditions. Also, an approach to modular termination analysis using procedure-level summaries is described in [7]. 2LS has an experimental implementation for these algorithms. The works [7, 33] investigate how to solve approximate solutions to these inter-procedural formulae that result from modular analysis. Moreover, the works [7, 21] also look into under-approximating backwards analysis in an inter-procedural context.

6.3 Non-Termination Analysis

2LS implements two techniques for *proving non-termination* [24, 25]. Both of the approaches are relatively simple, yet appear to be reasonably efficient in many practical cases.

The first approach is based on finding *singleton recurrent sets*. All loops are unfolded k times (with k being incrementally increased), followed by a check whether there is some loop L and a program configuration that can be reached at the head of L after both k' and k unwindings for some $k' < k$. Such a check can be easily formulated in 2LS as a formula over the SSA representation of programs with loops unfolded k times. This technique is able to find lasso-shaped executions in which a loop returns to the same program configuration every $k - k'$ iterations after k' initial iterations.

The second approach tries to reduce the number of unwindings by looking for loops that generate an *arithmetic progression* over every integer variable. More

precisely, it looks for loops L for which each integer variable x can be associated with a constant c_x such that every iteration of L changes the value of x to $x + c_x$, keeping non-integer variables unchanged. Two queries are used to detect such loops: the first one asks whether there is a configuration \bar{x} and a constant vector \bar{c} (with the vectors ranging over all integer variables modified in the loop and constants from their associated bitvector domains) such that one iteration of L ends in the configuration $\bar{x} + \bar{c}$, while the second makes sure that there is no configuration \bar{x}' over which one iteration of L would terminate in a configuration other than $\bar{x}' + \bar{c}$. If such a loop L and a constant vector \bar{c} are found, non-termination of L can be proved as follows: First, we gradually exclude each configuration \bar{x} reachable at the head of L for which there is some k such that L cannot be executed from $\bar{x} + k \cdot \bar{c}$ (intuitively meaning that L cannot be executed $k + 1$ times from \bar{x}). Second, we check whether there remains some non-excluded configuration reachable at the head of L .

The termination and non-termination analyses are run in parallel, and the first definite answer is used. Among the non-termination analyses, several rounds of unwinding are first tried with the singleton recurrence set approach. If that is not sufficient, the arithmetic progression approach is tried. If that does not succeed either, further rounds of unwinding with the former approach are run.

6.4 Memory Safety

Analysing memory safety requires reasoning about values of pointers and about the shape of the program heap. To this end, we introduce an abstract domain for heap analysis—a so-called *abstract shape domain* [22]. Memory safety analysis is based on computing invariants in this domain and then automatically generating assertions checking for absence of memory safety errors, such as null pointer dereference.

6.4.1 Abstract Domain for Heap Analysis

Similarly to all abstract domains in 2LS, the abstract shape domain has a form of a *template* describing the desired property. The shape of the heap is defined by pointer links among memory objects and therefore our shape domain is limited to the set Ptr of all pointers defined by (2). More particularly, since the shape domain is used to infer loop invariants, we limit it to the set Ptr^{lb} of all *loop-back* pointers.

Let L be the set of all loops in the analysed program. We define

$$Ptr^{lb} = Ptr \times L. \quad (28)$$

Elements of this set represent abstractions of values of individual pointers returning from the end of loop bodies that are introduced in our program representation (see Section 4.2). We denote loop-back pointers $(p, l) \in Ptr^{lb}$ by p_i^{lb} where i is the program location of the end of the loop l .

The shape domain over-approximates the *may-point-to* relation between the set Ptr^{lb} and the set of all symbolic addresses $Addr$. We define the form of the heap template to be the formula

$$\mathcal{T}^S \equiv \bigwedge_{p_i^{lb} \in Ptr^{lb}} \mathcal{T}_{p_i^{lb}}^S(d_{p_i^{lb}}). \quad (29)$$

The template is a conjunction of *template rows* $\mathcal{T}_{p_i^{lb}}^S$ where each row corresponds to a single loop-back pointer p_i^{lb} and it describes the points-to relation of that pointer. The parameter $d_{p_i^{lb}} \subseteq Addr$ of the row (i.e., the *abstract value of the row*) specifies the set of all addresses from the set $Addr$ that p may point to at the location i . The template row can be therefore expressed as a disjunction of equalities between the loop-back pointer and all possible addresses:

$$\mathcal{T}_{p_i^{lb}}^S(d_{p_i^{lb}}) \equiv \left(\bigvee_{a \in d_{p_i^{lb}}} p_i^{lb} = a \right) \quad (30)$$

Computing an invariant in the given abstract domain allows 2LS to characterize the shape of the program heap. For example, abstract values of template rows corresponding to pointer fields of abstract dynamic objects describe linked paths in the heap, such as linked segments.

6.4.2 Memory Safety Assertions

In order to analyse memory safety, 2LS automatically instruments the analysed program by assertions to check for typical memory safety errors [22, 23]. These are in particular pointer dereferencing errors, `free` errors, and memory leaks. We now describe the structure of these assertions.

Dereferencing/Freeing a null Pointer

To check for this kind of errors, 2LS adds an assertion $p \neq \text{null}$ to each program location where `*p` or `free(p)` occurs. Since the shape domain over-approximates the points-to relation, it is possible to soundly prove absence of such errors. If an error is found, BMC can be used to check whether it is spurious.

Dereferencing/Freeing a Freed Pointer

We introduce a special variable fr initialised to null that is used to track the possibly freed objects. Every call to `free(p)` in a program location i is replaced by a formula

$$fr_i = g_i^{fr} ? p_j : fr_k \quad (31)$$

where p_j and fr_k are relevant versions of p and fr , respectively, valid at i , and g_i^{fr} is a free Boolean variable. This formula represents a non-deterministic update of the value of fr by the freed address.

The shape domain is then used to over-approximate the set of all addresses that fr may point to, which is essentially the set of all possibly freed memory objects. Proving free safety is then done by adding an assertion $p \neq fr$ at each program location where $*p$ or $\text{free}(p)$ occurs.

The nature of the shape domain guarantees soundness of this approach, however, using it for abstract dynamic objects is often very imprecise. This is because freeing one of the concrete objects represented by the abstract one does not mean that the rest of the represented objects cannot be safely dereferenced or freed. This problem is resolved by modifying the representation of `malloc` calls described in Section 4.2.3.

In addition to the set AO_i of abstract dynamic objects used to represent all objects allocated at i , we add one object ao_i^{co} to AO_i . The object can be non-deterministically chosen as the `malloc` result (just like any other ao_i^k), however, it is guaranteed to represent a concrete object (i.e., it can be allocated only once). This is achieved by an additional condition asserting that ao_i^{co} cannot be allocated if there is a pointer pointing to it at the entry to the allocation site i . Therefore, the `malloc` representation has the form

$$p_i = (g_{i,co}^{os} \wedge \bigwedge_{p \in Ptr} p \neq \&ao_i^{co}) ? \&ao_i^{co} : (g_{i,1}^{os} ? \&ao_i^1 : (\dots)) \quad (32)$$

Afterwards, it is only allowed to assign the address of the concrete object ao_i^{co} to fr at each allocation site i . Checks for the free safety are also done on concrete objects only, which helps to avoid the described imprecision. This approach remains sound since ao_i^{co} represents an arbitrary object allocated at i and if safety can be proven for it, it can be assumed to hold for all objects allocated at i .

Memory Leaks Safety

Similarly to the previous section, the variable fr is used to check for safety from memory leaks. At the end of the program, we check whether there is an object ao_i^{co} such that $fr \neq \&ao_i^{co}$. If such an object is found, a memory leak is present. However, proving absence from memory leaks is only possible for loop-free programs (or for programs with all loops fully unwound). This is because we do not track sequencing of abstract objects representing concrete objects allocated at a single allocation site, and our analysis typically sees that ao_i^{co} can be skipped in deallocation loops, and hence remains inconclusive on the memory leaks.

6.5 Domain Combinations

One of the main advantages of program verification implemented in 2LS is that all abstract domains are required to have a common form of *templates*—quantifier-free first order formulae. Thanks to this feature, it is quite straightforward to create various compositions of different domains while relying on the solver to do the heavy-lifting on the domain operators combination and on mutual reduction of the domain abstract values. In 2LS, we use two such combinations: *product templates* and *power templates*, particularly their form called *templates with symbolic paths* [22].

6.5.1 Product Templates

Product templates are one of the simplest forms of abstract domain combination in 2LS. They are based on using a *Cartesian product template* that combines domains of various kinds side-by-side. This can be achieved by simply taking a conjunction of their templates.

A very interesting combination of this form is the combination of the shape and polyhedra abstract domains. It allows 2LS to analyse values of variables of pointer and numerical type at the same time. This helps not only for analysing program manipulating pointers and numbers at the same time but also opens a possibility to reason about contents of data structures at the program heap. Thanks to this combination, it is possible to verify programs such as the one in Figure 2.

6.5.2 Templates with Symbolic Paths

Using simple templates of invariants, such as the described polyhedra templates or the heap shape template, may not be precise enough to analyse some programs, especially programs working with abstract dynamic objects. In such programs, it is often required that an invariant computed for a loop l distinguishes which loops were or were not executed before reaching l . When working with abstract dynamic objects allocated in loops, this allows one to distinguish situations when an abstract dynamic object does not represent any really allocated object, and therefore an invariant describing it is not valid.

With respect to this, in order to improve precision, 2LS introduces the concept of *symbolic loop paths*. A symbolic loop path expresses which loops in the program were executed. Since 2LS uses loop-select guards to capture the control flow through the loops, a symbolic path is simply a conjunction of loop-select guard literals.

Formally, let G^{ls} be the set of all loop-select guards in the analysed program. A symbolic loop path π is defined as

$$\pi = \bigwedge_{g \in G^{ls}} l_g \quad (33)$$

where l_g is a literal of g , i.e., g or $\neg g$. We denote the set of all symbolic paths by Π . We also define a special path π_\perp containing negative literals only. For this path, no loop invariant is computed since no loops were executed for this path.

Having some template \mathcal{T} expressing an abstract domain (e.g. the shape domain or even a product domain), we define the corresponding template with symbolic paths as

$$\mathcal{T}^L \equiv \bigwedge_{\pi \in \Pi} \pi \implies \mathcal{T}. \quad (34)$$

This template can be viewed as a *power template*—in the sense of power domains—which assigns to each element of the base domain an element of the exponent domain.

The algorithm for inference of an invariant Inv^L from a symbolic path template is shown in Algorithm 14.

```

 $Inv^L \leftarrow true$ 
for  $\pi \in \Pi$  do
  add  $assert(\pi)$  to solver
   $Inv_\pi \leftarrow$  compute invariant from  $\mathcal{T}$ 
  remove  $assert(\pi)$  from solver
  if  $(\pi \wedge Inv_\pi)$  is satisfiable then
     $Inv^L \leftarrow Inv^L \wedge (\pi \implies Inv_\pi)$ 
  end if
end for

```

Fig. 14: Algorithm for inferring an invariant from a symbolic paths template.

The algorithm computes a separate invariant Inv_π in the inner domain (using the template \mathcal{T}) for each symbolic path π . To limit the invariant computation for π only, we assert that π (a formula expressing which loops are executed) holds during the computation. It may also happen that, after computing Inv_π , the symbolic path is in fact not reachable in the analysed program. Therefore, we check its reachability by solving $\pi \wedge Inv_\pi$ in the context of the formula generated from the SSA of the analysed program. If π is reachable, then $\pi \implies Inv_\pi$ is conjoined into the resulting invariant, otherwise Inv_π is discarded.

7 Implementation and Architecture of 2LS

2LS is based on the CPROVER framework.⁸ 2LS is implemented in C++ and currently has around 25 KLOC (not counting CPROVER itself). 2LS does not have any external dependencies beyond CPROVER and can therefore be built on many platforms. However, it is currently well-tested under Linux only.

⁸ <https://www.cprover.org>

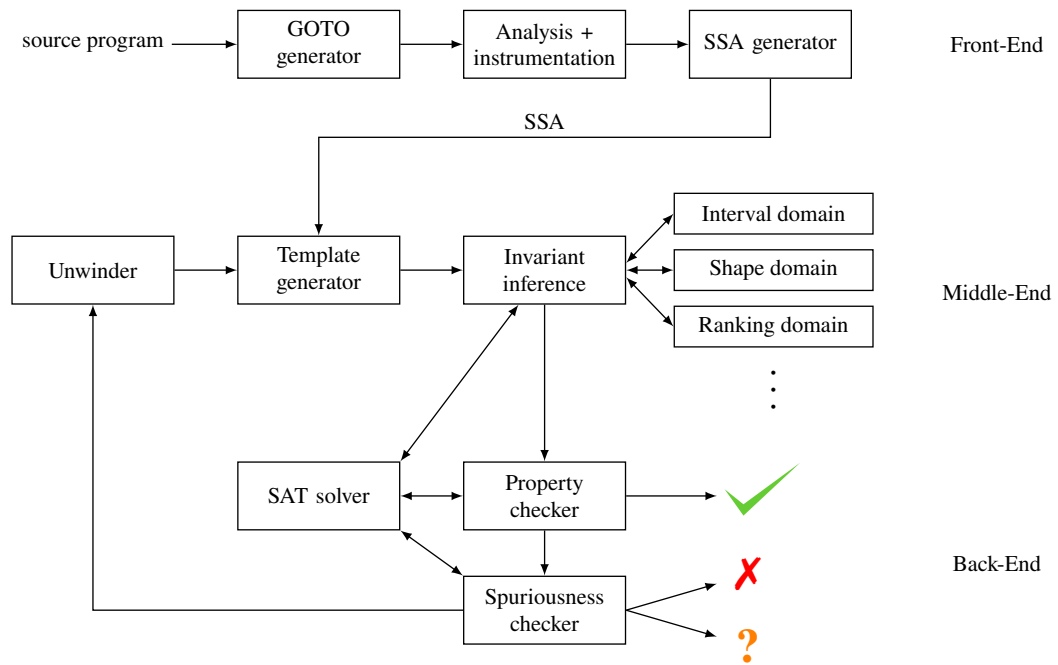

Fig. 15: 2LS architecture overview.

The source code is available at <https://www.github.com/diffblue/2ls> under the BSD license. 2LS was initially developed by Daniel Kroening and Peter Schrammel in 2014 and has received contributions by more than 15 contributors since then.

2LS is compatible with most of CPROVER tools such as `goto-cc`, a drop-in replacement for GCC, which can be used to build and link C source code using the existing build system of the project to be analysed. The resulting *goto binary* can be passed to 2LS and other CPROVER tools for analysis, e.g. CBMC.

Architecture

Similarly to other verification tools, 2LS follows the pipeline architecture of compilers, consisting of a front-end for parsing and type checking the source code; middle-end passes for transforming and optimising the code based on an intermediate representation (typically in the single static assignment form, SSA); and a back-end, which, however, instead of code generation performs the analysis and verification. An overview of the 2LS architecture is shown in Figure 15.

8 Evaluations

We now present results of the 2LS framework in the International Competition on Software Verification (SV-COMP). 2LS has competed in SV-COMP since 2016. In the first part, we compare the score that 2LS achieved over the years in chosen categories that require the kinds of analyses that 2LS implements. In the second part, we present some alternative rankings of the participating tools that demonstrate strengths of 2LS other than just the amount of programs successfully verified (e.g., time or power consumption).

8.1 Scores in SV-COMP

In this section, we show how the score obtained by 2LS in SV-COMP evolved over the years (from 2016 to 2022). We highlight the important milestones that caused a significant rise in the score and we also mention some of the tool’s achievements.

Since SV-COMP consists of a large variety of verification tasks, we chose several categories on which we demonstrate the tool’s abilities. We concentrate on categories containing tasks whose verification requires program analysis techniques that 2LS provides and that were described throughout this chapter. In particular, we show the score in the following categories:

Loops + Floats Here, we give the sum of the scores obtained in the *Floats* and the *Loops* sub-categories of the *reachability safety* category⁹. Verification of programs in these categories requires inference of invariants over numerical variables, which 2LS does using the template polyhedra domain (Section 6.1). In particular, we always used interval templates.

Heap One of the strengths of 2LS is analysis of heap-manipulating programs. In SV-COMP, these are located in the *ReachSafety-Heap* sub-category (where reachability of user-defined assertions is checked) and in the *MemSafety* category (where tools verify absence of memory-safety errors). This part gives the sum of these two (sub-)categories. In order to analyse programs in this part, 2LS uses the abstract shape domain described in Section 6.4.1.

Termination Besides verification of safety properties, 2LS allows to verify termination of programs by employing both termination (Section 6.2) and non-termination (Section 6.3) analysis and running them in parallel. In SV-COMP, termination is verified in the *Termination* category.

Overall The last kind of results that we show are those from the *Overall* category that contains a (normalized) score obtained from verification of all task programs in SV-COMP.

⁹ In 2016, the SV-COMP categories layout was quite different from the current one, however, the *Floats* and the *Loops* categories already existed. *Floats* was a standalone category, while *Loops* was a sub-category of *IntegersControlFlow*. The presented results from 2016 show score obtained in these (sub-)categories.

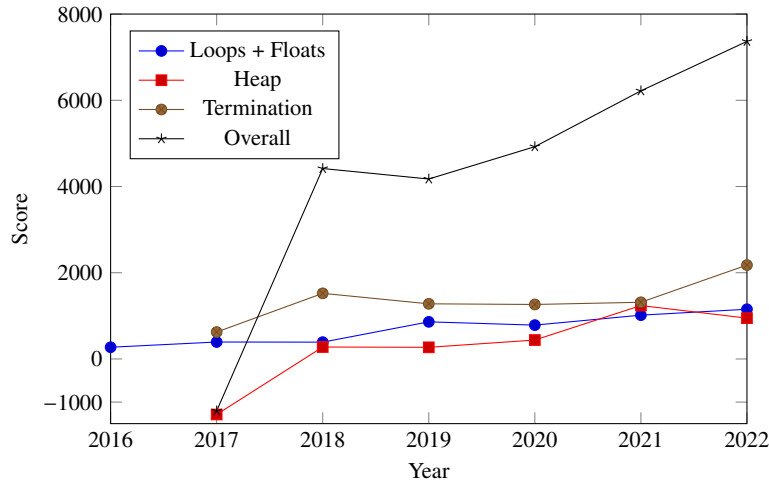

Fig. 16: Chosen results in SV-COMP 2016-2022

Figure 16 shows the evolution of the score that 2LS achieved in these categories between years 2016 and 2022 (in 2016, 2LS did not compete in most of the categories). The most remarkable improvement can be seen in 2018, where the score in the heap and the termination categories improved heavily, which caused also an improvement of the overall score. The reason for this is that in 2018, the abstract shape domain and the non-termination analysis were added to 2LS.

Next, we select some achievements of 2LS in the mentioned categories, which support claims about the framework’s strengths:

- **first** place in *Floats* and **second** place in *Loops* in 2016,
- **third** place in *Termination* in 2020, 2021, and 2022
- **fourth** place in *Heap* in 2019.

Last, one of the strengths of 2LS is the capability to reason about the shape and content of unbounded dynamic data structures at the same time (thanks to abstract domain combinations presented in Section 6.5). There is no separate category for such programs; the only task programs requiring such reasoning were added by our team in 2019 [22]. In 2022, 2LS remains one of the only two tools that are capable to verify majority of these tasks.

8.2 Alternative Rankings

Besides the ability to soundly and correctly verify programs, there are other properties that may support practical usefulness of a verification tool. In this section,

we compare 2LS to other verifiers using some alternative metrics, in particular *verification speed*, *energy consumption*, and *correctness rate*.

8.2.1 Speed of Verification in 2LS

One property that can be observed from the SV-COMP results is that 2LS verifies most of the tasks in a very short time, compared to other tools. We support this claim by an experiment where we set a small time limit and then observe how 2LS would compete against other tools in SV-COMP'22. Table 2 shows the position that 2LS would achieve in some of the main categories if the time limit was set to 5 seconds.

Table 2: Position of 2LS in some SV-COMP'20 categories with a 5s time limit.

ReachSafety	MemSafety	NoOverflows	Termination	Overall
5.	5.	1.	1.	2.

The table shows that 2LS would achieve a high position in all of the mentioned categories. A notable result is the first place in the *Termination* and *NoOverflows* categories and the second place in the *Overall* category.

8.2.2 Power Consumption and Correctness Rate

In recent years, the competition report of SV-COMP [1] provides two *alternative rankings* of verifiers that honor different aspects of the verification process. These are in particular:

- *Correct Verifiers* which ranks the verifiers by a so-called *correctness rate*, which is a ratio of the number of incorrect results and the overall achieved score. 2LS finished third in this ranking in 2020 with only 0.0016 errors per score point¹⁰.
- *Green Verifiers* which ranks the verifiers by the amount of energy used to achieve a single score point. In 2020 and 2021, 2LS finished second in this ranking by using only 180 J per score point.

8.3 Evaluation Conclusion

Overall, we summarize the observations obtained from the SV-COMP results. 2LS is able to prove true properties as well as to find counterexamples to property violations.

¹⁰ In SV-COMP, a tool is granted 1 point for finding a bug in the program and 2 points for proving the program safe. The final score is then computed by normalisation of the scores obtained in the individual categories

Most of the tasks that it is capable to prove, it proves very fast, mainly thanks to the incremental unwinding of a single SAT instance.

However, 2LS does not scale to more complex problems. Reasons for this are multiple: templates may be too weak, invariant inference does not scale to complex templates, or k -induction often does not succeed.

Moreover, 2LS still lacks support for verification of a number of features of programs, such as array contents, concurrency, or recursion. These prevent 2LS from better positions in some categories (MemSafety, Overall).

9 Conclusions and Prospects

2LS is a verification system for C programs that is based on a simple combination of bounded model checking, k -induction, and template-based invariant inference. The simplicity of the framework makes it easy to experiment with new abstract domains. 2LS beats most other state-of-the-art tools in terms of speed, but it still lagging behind in terms of robustness and feature support. For example, concurrency is not supported yet. Also, recursion is not yet supported by its incremental structural transformation algorithms. Further improvements of the memory model will be required to handle properties such as absence of memory leaks. Invariant inference for arrays is another area of ongoing work.

References

1. Beyer, D.: Advances in automatic software verification: Sv-comp 2020. In: A. Biere, D. Parker (eds.) Tools and Algorithms for the Construction and Analysis of Systems, pp. 347–367. Springer (2020)
2. Biere, A., Cimatti, A., Clarke, E.M., Zhu, Y.: Symbolic model checking without BDDs. In: Tools and Algorithms for the Construction and Analysis of Systems, *Lecture Notes in Computer Science*, vol. 1579, pp. 193–207. Springer (1999)
3. Bradley, A.R., Manna, Z.: Checking safety by inductive generalization of counterexamples to induction. In: Formal Methods in Computer-Aided Design, pp. 173–180. IEEE Computer Society (2007)
4. Brain, M., Joshi, S., Kroening, D., Schrammel, P.: Safety Verification and Refutation by k -Invariants and k -Induction. In: Static Analysis Symposium, *Lecture Notes in Computer Science*, vol. 9291, pp. 145–161. Springer (2015)
5. Brauer, J., King, A., Kriener, J.: Existential quantification as incremental SAT. In: Computer-Aided Verification, *Lecture Notes in Computer Science*, vol. 6806, pp. 191–207. Springer (2011)
6. Cabodi, G., Camurati, P., Mishchenko, A., Palena, M., Pasini, P.: SAT solver management strategies in IC3: an experimental approach. *Formal Methods in System Design* **50**(1), 39–74 (2017). DOI 10.1007/s10703-017-0272-0. URL <https://doi.org/10.1007/s10703-017-0272-0>
7. Chen, H.Y., David, C., Kroening, D., Schrammel, P., Wachter, B.: Bit-Precise Procedure-Modular Termination Proofs. *TOPLAS* **40** (2017)

8. Clarke, E., Kroening, D., Lerda, F.: A tool for checking ANSI-C programs. In: Tools and Algorithms for the Construction and Analysis of Systems, *Lecture Notes in Computer Science*, vol. 2988, pp. 168–176. Springer (2004)
9. Clarke, E.M., Grumberg, O., Jha, S., Lu, Y., Veith, H.: Counterexample-guided abstraction refinement. In: Computer-Aided Verification, *Lecture Notes in Computer Science*, vol. 1855, pp. 154–169. Springer (2000)
10. Cousot, P., Cousot, R.: Abstract interpretation: A unified lattice model for static analysis of programs by construction or approximation of fixpoints. In: Principles of Programming Languages, pp. 238–252 (1977)
11. D’Silva, V., Haller, L., Kroening, D.: Abstract conflict driven learning. In: Principles of Programming Languages, pp. 143–154. ACM (2013)
12. Eén, N., Sörensson, N.: An Extensible SAT-solver. In: SAT, *Lecture Notes in Computer Science*, vol. 2919, pp. 502–518. Springer (2003)
13. Eén, N., Sörensson, N.: Temporal induction by incremental SAT solving. *Electronical Notes in Theoretical Computer Science* **89**:4, 543–560 (2003)
14. Gawlitza, T.M., Monniaux, D.: Improving strategies via SMT solving. In: ESOP, *Lecture Notes in Computer Science*, vol. 6602, pp. 236–255. Springer (2011)
15. Gawlitza, T.M., Seidl, H.: Precise relational invariants through strategy iteration. In: Computer Science Logic, *Lecture Notes in Computer Science*, vol. 4646, pp. 23–40. Springer (2007)
16. Gulwani, S., Srivastava, S., Venkatesan, R.: Program analysis as constraint solving. In: Programming Language Design and Implementation, pp. 281–292. ACM (2008)
17. Günther, H., Weissenbacher, G.: Incremental bounded software model checking. In: SPIN, pp. 40–47. ACM (2014)
18. Hoder, K., Bjørner, N.: Generalized property directed reachability. In: Theory and Applications of Satisfiability Testing, *Lecture Notes in Computer Science*, vol. 7317, pp. 157–171. Springer (2012)
19. Hooker, J.N.: Solving the incremental satisfiability problem. *JLP* **15**(1&2), 177–186 (1993)
20. Kim, J., Whittemore, J., Sakallah, K.A., Silva, J.P.M.: On applying incremental satisfiability to delay fault testing. In: DATE, pp. 380–384. IEEE Computer Society (2000)
21. Madhukar, K., Schrammel, P., Srivas, M.K.: Compositional safety refutation techniques. In: Automated Technology for Verification and Analysis, *Lecture Notes in Computer Science*, vol. 10482, pp. 164–183. Springer (2017)
22. Malík, V., Hruška, M., Schrammel, P., Vojnar, T.: Template-based verification of heap-manipulating programs. In: FMCAD, pp. 103–111 (2018)
23. Malík, V., Hruška, M., Schrammel, P., Vojnar, T.: 2ls: Heap analysis and memory safety (competition contribution) (2019). URL <http://arxiv.org/abs/1903.00712>
24. Malík, V., Martiček, Š., Schrammel, P., Srivas, M., Vojnar, T., Wahlang, J.: 2LS: Memory Safety and Non-termination (Competition Contribution). In: TACAS, pp. 417–421. Springer (2018)
25. Martiček, Š.: Synthesizing non-termination proofs from templates. Master’s thesis, Brno University of Technology, Brno (2017)
26. Marušák, M.: Generic template-based synthesis of program abstractions. Master’s thesis, Brno University of Technology, Brno (2019)
27. McMillan, K.L.: Lazy abstraction with interpolants. In: Computer-Aided Verification, *Lecture Notes in Computer Science*, vol. 4144, pp. 123–136. Springer (2006)
28. Miné, A.: The octagon abstract domain. In: Working Conference on Reverse Engineering, pp. 310–319. IEEE Computer Society (2001)
29. Monniaux, D., Schrammel, P.: Speeding up logico-numerical strategy iteration. In: Static Analysis Symposium, *Lecture Notes in Computer Science*, vol. 8723, pp. 253–267. Springer (2014)
30. Mukherjee, R., Schrammel, P., Haller, L., Kroening, D., Melham, T.: Lifting CDCL to template-based abstract domains for program verification. In: Automated Technology for Verification and Analysis, *Lecture Notes in Computer Science*, vol. 10482, pp. 307–326. Springer (2017)

31. Reps, T.W., Sagiv, S., Yorsh, G.: Symbolic implementation of the best transformer. In: Verification, Model Checking, and Abstract Interpretation, *Lecture Notes in Computer Science*, vol. 2937, pp. 252–266. Springer (2004)
32. Sankaranarayanan, S., Sipma, H.B., Manna, Z.: Scalable analysis of linear systems using mathematical programming. In: Verification, Model Checking, and Abstract Interpretation, *Lecture Notes in Computer Science*, vol. 3385, pp. 25–41. Springer (2005)
33. Schrammel, P.: Challenges in decomposing encodings of verification problems. In: HCVS@ETAPS 2016, *EPTCS*, vol. 219, pp. 29–32 (2016)
34. Schrammel, P., Kroening, D.: 2LS for Program Analysis - (Competition Contribution). In: Tools and Algorithms for the Construction and Analysis of Systems, *Lecture Notes in Computer Science*, vol. 9636, pp. 905–907. Springer (2016)
35. Schrammel, P., Kroening, D., Brain, M., Martins, R., Teige, T., Bienmüller, T.: Incremental bounded model checking for embedded software. *Formal Aspects of Computing* **29**(5), 911–931 (2017)
36. Sheeran, M., Singh, S., Stålmarck, G.: Checking safety properties using induction and a SAT-solver. In: FMCAD, *Lecture Notes in Computer Science*, vol. 1954, pp. 108–125. Springer (2000)
37. Silva, J.M., Sakallah, K.A.: Robust search algorithms for test pattern generation. In: FTCS, pp. 152–161. IEEE Computer Society (1997)
38. Strichman, O.: Pruning techniques for the SAT-based bounded model checking problem. In: CHARME, *Lecture Notes in Computer Science*, vol. 2144, pp. 58–70. Springer (2001)
39. Whittemore, J., Kim, J., Sakallah, K.A.: SATIRE: A new incremental satisfiability engine. In: DAC, pp. 542–545. ACM (2001)