

# Trusted And Confidential Program Analysis

Han Liu  
The Blockhouse Technology Ltd.  
Oxford, UK  
liuhan@tbtl.com

Pedro Antonino  
The Blockhouse Technology Ltd.  
Oxford, UK  
pedro@tbtl.com

Zhiqiang Yang  
The Blockhouse Technology Ltd.  
Oxford, UK  
zhiqiang@tbtl.com

Chao Liu  
The Blockhouse Technology Ltd.  
Oxford, UK  
liuchao@tbtl.com

A.W. Roscoe  
The Blockhouse Technology Ltd.  
University College Oxford Blockchain  
Research Center  
Oxford University  
Oxford, UK  
awroscoe@gmail.com

## Abstract

We develop the concept of Trusted and Confidential Program Analysis (TCPA) which enables program certification to be used where previously there was insufficient trust. Imagine a scenario where a producer may not be trusted to certify its own software (perhaps by a foreign regulator), and the producer is unwilling to release its sources and detailed design to any external body. We present a protocol that can, using trusted computing based on encrypted sources, create certification via which all can trust the delivered object code without revealing the unencrypted sources to any party. Furthermore, we describe a realization of TCPA with trusted execution environments (TEE) that enables general and efficient computation. We have implemented the TCPA protocol in a system called TCWASM for web assembly architectures. In our evaluation with 33 benchmark cases, TCWASM managed to finish the analysis with relatively slight overheads.

**Keywords:** Program analysis, regulatory property, trusted execution environment

## 1 Introduction

This paper offers a tentative solution to the following problem: vendor Alice wishes to sell executable software  $E$  to clients such as Bob. Bob does not trust Alice and wants to examine the high-level design or sources behind  $E$ , but Alice is unwilling to do this to protect her intellectual property. In

particular, the rapid growth of the international IT market, where IT products (e.g., software, hardware, services, etc.) are widely exported from one country to another has led to many such issues. Unfortunately, IT products are notoriously prone to bugs and security risks no matter in what forms they are deployed and in what environments they are running. Any vulnerable component in an IT product may cause a great loss to customers, e.g., national security threats, abuse of personal data, manipulation on digital asset, etc. In practice, the import and export of IT products are commonly required to be strictly compliant with local and international regulations. More importantly, such regulatory processes have to take place in a both *trusted* and *confidential* way, i.e., form a consensus on the regulatory compliance of an IT product among a group of relevant parties without leaking further sensitive information, e.g., source code, hardcoded values, etc. Figure 1 shows an illustrative example for further explanation.

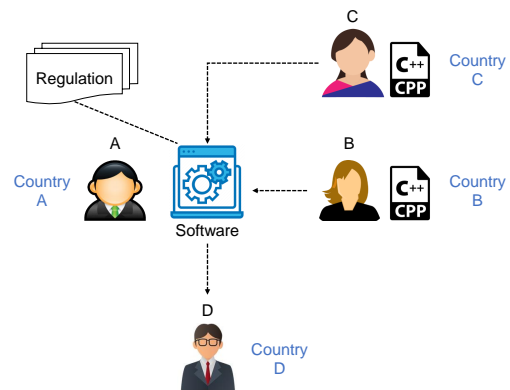

**Figure 1.** Multiparty trusted and confidential regulation.

**Illustrative Example.** We consider the case in which  $B$  and  $C$  have jointly developed software and exported it to  $A$ . As a service provider,  $A$  imported the software to set up

Permission to make digital or hard copies of all or part of this work for personal or classroom use is granted without fee provided that copies are not made or distributed for profit or commercial advantage and that copies bear this notice and the full citation on the first page. Copyrights for components of this work owned by others than ACM must be honored. Abstracting with credit is permitted. To copy otherwise, to republish, to post on servers or to redistribute to lists, requires prior specific permission and/or a fee. Request permissions from [permissions@acm.org](mailto:permissions@acm.org).

Conference'17, July 2017, Washington, DC, USA

© 2021 Association for Computing Machinery.

ACM ISBN 978-x-xxxx-xxxx-x/YY/MM. . \$15.00

<https://doi.org/10.1145/nnnnnnn.nnnnnnn>

a public service which further reached  $D$  as a general user. Although this case is designed for explanation, it actually abstracts a typical scenario where nowadays IT products are deployed and used worldwide. Considering that the four participants may be from different countries, they are required to follow various regulations. For  $B$  and  $C$  as software exporters, they need to be compliant with local export regulations. For  $A$  as a technology importer, his or her obligation is to check that the imported software introduces no regulatory risks, *e.g.*, national security issues. From the perspective of  $D$ , his or her country might only allow the service to reach domestic users if it poses no threats to the public good, *e.g.*, user privacy. In practice, it is hard to enforce the regulatory processes among these four parties due to the fact that the source code of the software is strictly confidential and therefore cannot be directly shared in a straightforward manner. Consequently, no single party in this case is able to believe that the software indeed delivers the required regulatory compliance across different countries.

**Trusted and Confidential Program Analysis.** To address this problem, we proposed a novel protocol in this paper to enable trusted and confidential program analysis (TCPA) for checking regulatory compliance of software across multiple parties without mutual trust. More specifically, the proposed protocol guarantees that a) imported or exported software  $E$  is indeed built from a given piece of secret source code  $C$ , b) both  $E$  and  $C$  are compliant with a set of mutually agreed regulatory properties  $P = \{p_1, p_2, \dots, p_n\}$ , *i.e.*,  $E, S \models P$  and c) the compliance of  $E$  and  $S$  is verifiable without revealing sensitive information of  $S$ . Furthermore, we described a realization of TCPA called TCWASM using trusted execution environments (TEEs) and applied the system for analysis of web assembly (WASM) programs. In the preliminary evaluation with 33 benchmark files, TCWASM finished the analysis tasks with slight overheads of 139.3% and 54.8% in terms of time and memory usage, respectively; the baseline system executes the same analysis tasks without relying on TEEs. These overheads seem entirely acceptable to us given the added guarantees in terms of trust and confidentiality that the use of TEEs provides.

We summarize our main contributions below.

- We describe the problem of trusted and confidential program analysis and present a formalization of it to guide our subsequent research.
- We propose the first protocol to enable TCPA in practice, which is consistent with popular trusted computing technologies such as TEEs.
- We realize the protocol using AMD's SEV TEE implementation. We develop the system TCWASM for verifying web assembly programs via TCPA; the first of its kind, to the best of the authors' knowledge.

- We have conducted a large-scale evaluation of TCWASM and here report empirical evidence to demonstrate the feasibility of applying TCPA in practice.

**Paper Organization.** The rest of this paper is organized as follows. §2 introduces background information. §3 presents an in-depth explanation of the TCPA protocol. §4 describes the system design of TCWASM. §5 summarizes empirical results of the evaluation and §6 discusses related works. §7 concludes the paper.

## 2 Background

### 2.1 Trusted Computing

*Trusted computing* [28, 39] describes a number of technologies proposed to mitigate security threats. Unlike conventional passive approaches such as firewalls, malware detection, and intrusion detection, trusted computing takes a more active approach to addressing these threats, *i.e.*, by establishing trust on a solid basis (typically referred to as the *root of trust* and implemented using both hardware and software) and then expanding this chain of trust to cover the entire computing system. Trusted Execution Environments represent arguably the most flexible and practical technology in this area. Some modern processors offer hardware primitives that support the execution of *isolated computations*, that is, the code and data they use are encrypted and integrity-protected. These TEE implementations are designed so that even the operator of the machine where such an execution takes place is unable to undetectably tamper with, or learn secrets manipulated by this execution. We use the terms TEE and TEE implementation interchangeably. Note that a TEE can be managing and executing multiple isolated computations concurrently. Examples of TEE implementations available are Intel's Software Guard Extensions (SGX) [17], AMD's Secure Encrypted Virtualization (SEV) [48], and ARM's TrustZone [41]. Each of them is designed to address different application scenarios, but they all share similar core capabilities. We introduce some of these common building blocks as follows.

These implementations rely on special instructions to load the isolated computation's code and data, in encrypted form, into the *main memory*, while *measuring* them in the process, and execute it. They isolate computations at different levels of granularity. For instance, while AMD SEV isolates an entire virtual machine (VM), Intel SGX isolates part of a (operating-system) process. This measurement and the encrypted memory pages are created, managed, and protected by the TEE. The *attestation* process plays a key part in establishing the chain of trust. Roughly speaking, it generates cryptographically-protected evidence attesting that a computation with a given measurement has been properly isolated; it also attests the authenticity of the TEE implementation - hardware and software components - and its capabilities. By properly verifying this evidence, an entity interacting with

this computation can be confident of its isolation and, consequently, of the guarantees that follow. We detail this process later. For instance, in the case of AMD SEV, the attestation process can be used to establish that a VM has been properly set up by checking the boot process and the elements it depends upon have the expected measurements, i.e. OS image, installed programs and data, etc. The isolation offered by TEE implementations is restricted to the main memory. The developer of the isolated computation is responsible for encrypting data on disk.

## 2.2 Program Analysis

In general, program analysis develops on methods and technologies at establishing the relationship between a given software program and expected properties, e.g., correctness, robustness, safety and liveness. Typical program analysis tasks are program optimization, vulnerability detection, and formal verification. Considering the approaches taken, program analysis technologies can be categorized as static program analysis, dynamic program analysis, and both in combination. Static program analysis technology finishes its task by not running or executing the target program. Common static program analysis methods are control-flow analysis, data-flow analysis, abstract interpretation, type analysis, and pointer analysis. All of these methods first model the given program and its expected property abstractly as a set of mathematical constraints, for which the analysis task boils down to establishing satisfiability. In contrast, dynamic program analysis fulfills its goal by examining actual runs of the target program and checking for the expected properties. Fuzzing, symbolic execution, and runtime monitoring are among the most frequently used dynamic program analysis technologies. While static and dynamic program analysis have their strengths in efficiency and precision, respectively, neither of them is able to tackle all real-world problems. Thus, there is another category of *hybrid* program analysis technologies which combines both approaches. TCPA encompasses all of these.

## 3 Protocol For TCPA

### 3.1 Overview

The general workflow of TCPA is shown in Figure 2. The protocol defines the following types of actors, namely, Provider (Alice), Consumer (Bob), and the Trusted and Confidential Program Analysis Isolated Computation (*TCPA-IC*). Alice is the software provider in this setting who wants to export her products to the Consumer Bob and therefore needs to convince him that the exported software is strictly compliant with regulations. As aforementioned, Alice also needs to avoid revealing the product's business secrets (e.g., source code) to non-relevant parties such as Bob. In this set-up, Bob hosts the TEE where *TCPA-IC* is to be executed. He is in charge of setting up the TEE-enabled platform and *TCPA-IC*.

Even with unlimited access to the platform, not even Bob can infer any secrets from this compliance analysis since the product is analysed within the isolated service *TCPA-IC*. Of course, we could have an alternative setup where Alice or a third party would host the TEE where *TCPA-IC* executes. This set-up, however, reinforces and highlights that even the platform's operator, with unrestricted access, cannot read into the isolated computation's execution.

Important concepts in TCPA as listed below.

- $S$  is the source code of a given piece of software.
- $E$  is the executable corresponding to  $S$ .
- $P = \{p_1, p_2, \dots, p_n\}$  is a set of regulatory properties to be checked.
- $X$  is a program analysis framework, e.g., static analysis, dynamic analysis.
- $B$  is the building framework of  $S$ , i.e., create  $E$  from  $S$ . The most common example of  $B$  is a compiler.
- $TCPA-IC(X, B, P)$  is the isolated computation that carries out the indicated trusted and confidential program analysis.
- Public and private keys  $IC_{pub}$  and  $IC_{priv}$ , respectively, are elements of a signature scheme used to authenticate messages issued by  $TCPA-IC(X, B, P)$ .
- $T$  is a symmetric key for encryption and decryption.  $S_T$  indicates an encrypted version of  $S$ .
- The platform certificate ( $PC$ ), isolated computation certificate ( $ICC$ ), and compliance certificate ( $CC$ ) attest the platform's capabilities, the isolated computation's measurement, and the program analysis' outcome, respectively - we detail these elements in the following.

### 3.2 Platform set-up

Before the protocol in Figure 2 can be executed, we assume a *platform setup* step; omitted from that figure for the sake of simplicity. In this step, the platform engage in a protocol with the processor manufacturer, who is typically also the TEE implementer, aimed at proving the processor's authenticity, its capability to run isolated computations, and that all the trusted elements - both hardware and software - part of the TEE implementation are valid and have been properly set up. Manufacturers store a non-exportable secret in the chip's fuses that allows them to authenticate processors. Once a chip is authenticated and its capabilities checked, low-level primitives can be trusted to correctly validate hardware and software components of the TEE implementation. As a result of this process, the processor's manufacturer issues a *platform certificate* ( $PC$ ) - we describe this certificate and its elements as follows.

- The manufacturer's public and private *root of trust* keys  $RoT_{pub}$  and  $RoT_{priv}$ , respectively, are elements of a signature scheme used to authenticate messages issued by this actor. The public component is well-known and trusted to be the correct *root of trust* key for the manufacturer.

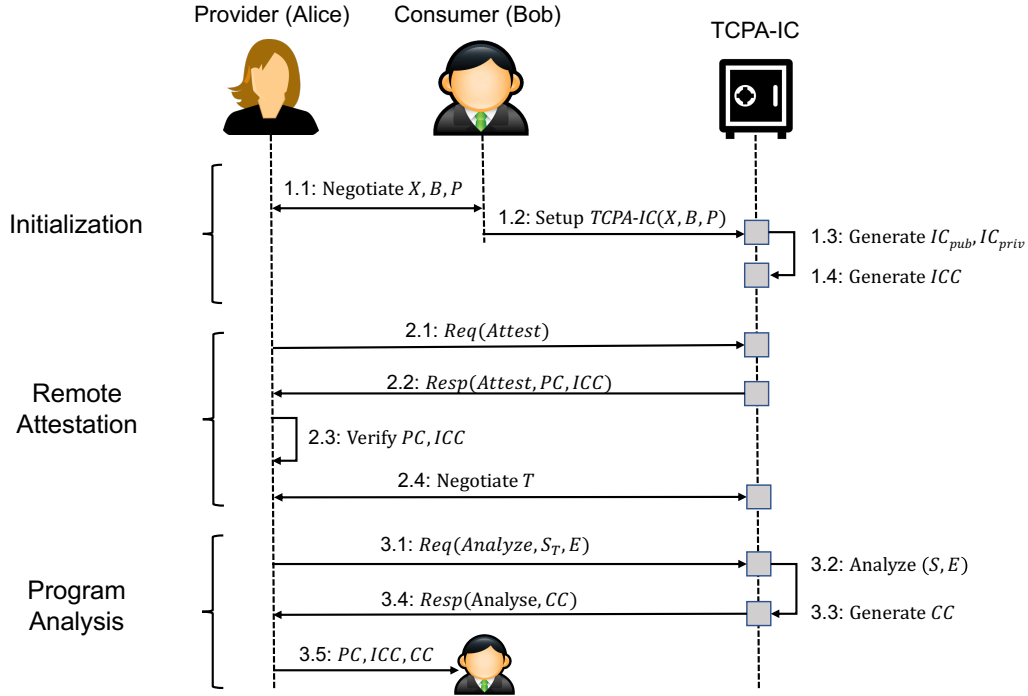

Figure 2. The protocol of TCPA.

- The platform’s public and private *protected keys*  $Plat_{pub}$  and  $Plat_{priv}$ , respectively, are elements of a signature scheme used to authenticate messages issued by this actor, and more specifically its TEE. These keys are managed by the TEE implementation and not even the platform owner has access to the private components.
- $PC = (Plat_{pub})_{RoT_{priv}}$  is a certificate containing the platform’s protected public key and a cryptographic signature of this key issued by the processor’s manufacturer using  $RoT_{priv}$ .
  - In this paper, we use  $(el_1, \dots, el_n)_k$  to denote a certificate containing the elements  $el_1, \dots, el_n$  together with a cryptographic signature of them using key  $k$ .

This certificate is evidence that the platform’s TEE is valid and has been properly set up, and its authenticity can be verified using  $RoT_{pub}$ . It also vouches for the platform protected key  $Plat_{pub}$ . As we detail later, this certificate and the elements above play a part in the attestation process.

As shown in Figure 2, the protocol works in three phases, *i.e.*, initialization, remote attestation and program analysis. We now describe them in detail.

### 3.3 Initialization

The initialization phase of TCPA begins with Producer and Consumer agreeing on the program analysis framework  $X$ , building framework  $B$ , and regulatory properties  $P$  that are to be used by our isolated computation  $TCPA-IC$ . Once they have agreed on these parameters, Bob creates the isolated

computation  $TCPA-IC(X, B, P)$  as he is the owner of the platform. Thus, the code and data used by  $TCPA-IC(X, B, P)$  is loaded in encrypted form, measured, and executed. Once this service starts, it generates its own key pair using a trusted source of randomness, and the *isolated computation certificate* ( $ICC$ ). We define these elements as follows.

- The  $TCPA-IC(X, B, P)$  public and private keys  $IC_{pub}$  and  $IC_{priv}$ , respectively, are elements of a signature scheme used to authenticate messages issued by this actor. These keys are managed by the isolated computation process  $TCPA-IC(X, B, P)$  and not even the platform owner has access to the private components.
- $ICC = (m_{IC}, IC_{pub})_{Plat_{priv}}$  is a certificate containing the cryptographic measurement of the isolated computation process  $TCPA-IC(X, B, P)$  given by  $m_{IC}$ , and  $TCPA-IC(X, B, P)$ ’s public key  $IC_{pub}$ . The certificate is signed by the platform’s protected private key  $Plat_{priv}$ . The measurement  $m_{IC}$  is a cryptographic hash of the memory pages, *i.e.*, code and data, loaded into main memory corresponding to  $TCPA-IC(X, B, P)$ ; it accounts for the parameters  $X, B$  and  $P$ .

This certificate provides evidence that an isolated computation with measurement  $m_{IC}$  has been created by a platform identified by key  $Plat_{pub}$ , and that this computation certified the blob of data, which happens to be its public key,  $IC_{pub}$ . While the measurement of the computation is calculated and set by the TEE, the isolated computation is free to pass any extra blob of data to be certified. Thus, while the

measurement can be trusted to be correct, provided that the platform and TEE are trusted, the blob of data must only be relied upon if the isolated computation's code request the certification of the appropriate data.

### 3.4 Remote Attestation

The remote attestation process should provide enough evidence to convince Alice (Provider) that the expected isolated computation has been properly set up and started in a valid TEE-enabled platform. This phase begins by Alice requesting both the platform and isolated computation certificates  $PC$  and  $ICC$ . Once she receives them, Alice can verify this *attestation certificate chain*. She knows and trusts the manufacturer's  $RoT_{pub}$  key. Therefore, she can use this key to verify  $PC$ 's signature/authenticity. Once this certificate is verified, she can extract the platform protected key  $Plat_{pub}$  from it and use this key to verify  $ICC$ . The last step in this verification process consists of checking for the expected measurement. Alice calculates the measurement that she expects for  $TCPA-IC(X, B, P)$  - let us call it  $m_{exp}$  - and then compares it to the  $m_{IC}$  element of  $ICC$ . If any of these verifications fail, Alice stops taking part in the protocol. If all of them succeed, however, Alice should be convinced that  $TCPA-IC(X, B, P)$  has been correctly isolated, it is the computation expected, and, as part of its execution, its public key  $IC_{pub}$ , an element of certificate  $ICC$ , has been certified. In the final step in this phase Alice and  $TCPA-IC(X, B, P)$  negotiate  $T$ : a symmetric encryption scheme key used to confidentially transmit data between them. This key is negotiated in a way that it does not become known to Bob, say using some form of the Diffie-Hellman key exchange method. The key pair  $IC_{pub}$  and  $IC_{priv}$  can be used to authenticate  $TCPA-IC(X, B, P)$ 's messages in this negotiation process.

### 3.5 Program Analysis

The program analysis phase of our protocol involves the examination of  $S$  and  $E$ . Alice starts this phase by sending  $S_T$  and  $E$  to  $TCPA-IC(X, B, P)$ . The isolated computation, then, decrypts  $S_T$  and proceeds to check: (i) whether  $S$  meets the properties  $P$ , and (ii) whether  $E$  is an executable capturing the behaviour of  $S$ . In principle, TCPA does not limit the type of analysis run by  $TCPA-IC$ , that is, any well-defined framework could be used to verify  $S$ 's compliance with  $P$  and  $E$ 's correspondence to  $S$ . Figure 3 illustrates a framework to check both (i) and (ii). The left part demonstrates a typical analysis flow based on symbolic execution. The source code of a program is firstly taken by CFG builder to generate a control flow graph, *i.e.*, CFG. Then, a symbolic execution engine is triggered to explore the CFG with symbolic inputs. In the process of symbolic execution, symbolic traces are produced for further analysis. For a specific trace, a semantic analyzer checks whether the properties hold or not. Lastly, an analysis report is generated as a summary of the process. The design

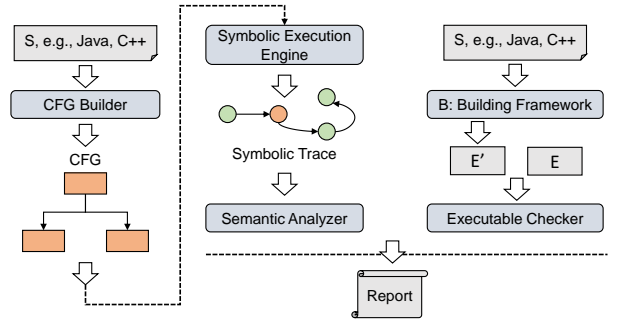

Figure 3. The workflow of program analysis.

of a specific program analysis technique is not our main focus in this paper, and as mentioned before, other verification frameworks could be plugged into our TCPA protocol. The right part of this framework describes a process to determine  $E$ 's correspondence to  $S$ . Specifically, an executable  $E'$  is built with  $B$  for the given  $S$ . Then,  $E'$  is compared with  $E$  (*i.e.*, executable provided by Alice) using an executable checker that syntactically compares them for equality. If so, it is safe to conclude that  $E$  corresponds to  $S$ . Of course, we could have more sophisticated executable checkers where some form of *semantic* equivalence between  $E$  and  $E'$  could be checked instead. Furthermore, we could even completely bypass this comparison step, and return  $E'$  to Alice. Given that this executable was created by  $TCPA-IC(X, B, P)$  using  $B$  and that  $B$  is trusted to be correct,  $E'$  should correspond to  $S$ . Once the analysis is finished,  $TCPA-IC(X, B, P)$  creates the *compliance certificate* ( $CC$ ) as follows.

- $CC = (h(S), E, R)_{IC_{priv}}$  contains a cryptographic hash of  $S$  (*i.e.*,  $h(S)$ ), the executable  $E$  sent by Alice, and an analysis report  $R$ , and it is signed using the computation  $TCPA-IC(X, B, P)$ 's private key  $IC_{priv}$ . The report  $R$  is a pair  $(eo, (po_1, \dots, po_n))$  where  $eo$  is the executable equality outcome - a boolean that is true if they are equivalent, and false otherwise - and the tuple  $(po_1, \dots, po_n)$  has a property verification outcome  $po_i$  for each corresponding to property  $p_i$  in  $P$ . The format of property outcomes  $po_i$  will vary based on the choice of source code and property languages, and verification framework. For instance, considering stochastic systems and verification frameworks, a property outcome would present the likelihood of a property being valid. On the other hand, a non-stochastic model checker applied to a deterministic program could output precisely whether a property holds. There are even non-stochastic approximate analysers which might admit an *unknown* outcome when they cannot issue a definitive statement about the specific  $S$  and  $p_i$  being analysed. These approximations are typically used for the sake of decidability or efficiency.

Finally,  $CC$  is sent back to Alice which can forward  $PC$ ,  $ICC$  and  $CC$  to Bob. He can then verify this certificate chain

just like Alice does on the remote attestation phase with the extra steps that  $CC$ 's signature must be verified against  $IC_{pub}$  and that the report  $R$  in  $CC$  must have the executable equality outcome set to true and that all properties are valid. If the verification of this certificate chain succeeds, Bob trusts  $R$  - and, consequently, the compliance status of  $E$  - and can start using this product.

In this protocol, neither Alice or Bob authenticate any messages by, say, signing them. We could, of course, require that Alice and Bob have a key pair each, for which public component is known to the other participant, that they could use to set up authenticated and confidential channels between them using well-known cryptographic protocols. The protocol could then take place over these channels. We do not detail this set-up as our primary goal in this paper is to introduce a protocol by which Bob can be convinced of  $E$ 's (and  $S$ 's) compliance without having access to  $S$  and not make it confidential to other parties.

Perhaps one interesting addition to the protocol would be a *certificate of origin* provided by Alice. In the current version of the protocol, Bob can verify that  $E$  meets the expected regulatory properties, but the protocol does not have any mechanism to tie  $E$  and  $S$  to Alice. Of course, Bob might be satisfied that  $E$  complies with  $P$  alone, regardless of who the author of  $E$  or  $S$  is. However, Bob could also demand to know their author so that he can later raise a dispute related to  $E$  against its author, for instance. To satisfy this demand, the protocol could be extended with an extra step by which Alice generates an origin certificate ( $OC$ ) containing the  $h(S)$  and  $E$ , and cryptographically signed by its private key  $A_{priv}$  - the public counterpart  $A_{pub}$  of which is known to Bob. This certificate attests Alice's authorship and can be verified by Bob using  $A_{pub}$ . This certificate together with  $h(S)$  in  $CC$  commits Alice to the source code used in TCPA. Thus, she cannot claim a different source code was used by the protocol in a possible dispute resolution process.

Note that, as the platform owner/TEE host, Bob has unrestricted access to the messages transiting between Alice and  $TCPA-IC(X, B, P)$ , and to the platform and TEE running this isolated computation, and yet he is unable to learn anything about the source code  $S$  apart from its compliance status with respect to properties  $P$  and that it gives rise to executable  $E$ . He does not have access to the source code when sent by Alice to  $TCPA-IC(X, B, P)$  as the negotiated symmetric key  $T$  is not known to him, and the TEE managing the execution and isolation of  $TCPA-IC(X, B, P)$  prevents him from accessing this secret when its compliance analysis is being carried out.

Regulators may also impose restrictions on the verification framework  $X$  used to verify whether  $S$  meets  $P$ . They could, for instance, have a list of approved frameworks, and expect only those to be used in the context of  $TCPA-IC$ . The measurement of  $TCPA-IC(X, B, P)$  - which depends on  $X$ ,  $B$ , and  $P$  - can be used to show that an approved framework has been indeed used. A party using our protocol ought

to be able to independently calculate the measurement of  $TCPA-IC(X, B, P)$ , given  $X$ ,  $B$ , and  $P$ , for the sake of confirming it is interacting with the appropriate isolated computation in the process of remote attestation. Therefore, it can use this trusted measurement to test if a given framework  $X'$  was used and, then, check whether  $X'$  is in the list of approved frameworks. More sophisticated procedures could be devised to ensure a given verification framework meets the norms of a regulator, including having its code verified for some properties using perhaps its own separate  $TCPA-IC$  instantiation for that.

It is worth mentioning that verification frameworks can be non-deterministic, that is, for some frameworks, two executions checking the same system and property can give rise to different verification outcomes. The parties relying on our protocol must keep this sort of behaviour in mind as it can be maliciously exploited. Let us say, for instance, that a verification framework in very rare occasions fail to report that a property is violated, returning that it was unable to assert the property instead, and let us assume that this sort of *unknown* result is good enough to pass some regulation. This sort of behaviour could be explained, for instance, if we had a verifier  $X'$  that has a constraint on the number of states it can examine, and so, for a given input system  $S'$ , a large randomly-selected portion of its state space can be analysed but not all of it. In such a case, a malicious party could re-analyse  $S'$  using our protocol until  $X'$  misses the small fraction of states of  $S'$  that witness the violation. Thus, the consumer  $B$  might then need to know that the TCPA analysis is instigated by someone he trusts such as  $B$  himself - as it is in the detailed protocol we have set out. Program analysis typically produces reports in addition to a yes/no/unknown result. In TCPA, the form of a report, e.g., an exception leading to a counter example, may need to be withheld from the software customer because it gives away details of the confidential sources.

## 4 Design of TCWASM

### 4.1 Architecture

We realized the TCPA protocol as described above in the TCWASM system to enable trusted and confidential program analysis for programs that compile to web assembly (WASM). Specifically, we used the AMD SEV [48] as the underlying trusted execution environment and a symbolic-execution-based engine to deliver program analysis [54]. The architecture of TCWASM is shown in Figure 4.

In general, TCWASM is implemented as a form of cloud service and is compatible with any existing platform, e.g., Amazon, Google, Alibaba etc. We offer four types of sub-services for end users, e.g., Alice and Bob in Figure 2, who are trying to agree on the regulatory compliance of a confidential software. The functionalities of these sub-services are summarized below.

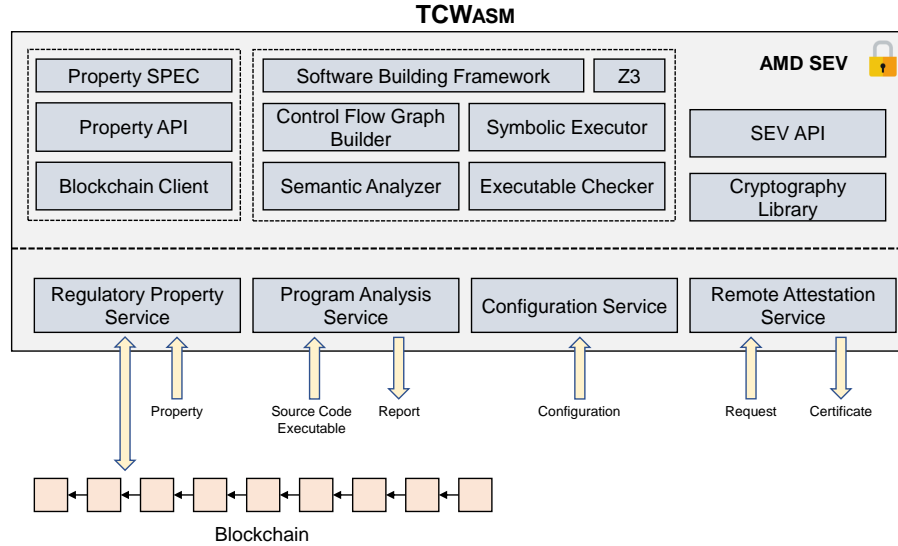

Figure 4. The architecture of TCWASM.

- **Regulatory Property Service** allows a software customer to publish an agreed set of regulatory properties which will be verified for the software created by a provider later in TCWASM. The agreement on properties is formed with signatures of both the provider and customer included. The service also offers accesses to properties that are publicly available. Any relevant participant - *e.g.*, downstream users, audit teams, *etc* - can check the properties managed on TCWASM and understand the compliance guarantee from their own perspective.
- **Program Analysis Service** runs the underlying analysis processes to decide whether the given software is compliant with the specified set of properties. As illustrated in Figure 2, the provider is required to submit an encrypted version of source code and the deployed executable. The service will generate a certificate of compliance as a form of report for relevant parties, *e.g.*, the customer, to confirm that the specified computation process has been executed on the given software and yielded a compliance decision for it to explain whether the software satisfies the properties, and why it is the case.
- **Configuration Service** helps users configure TCWASM based on their preference. Practically, it is reasonable to make the projection that TCWASM will probably have a collection of program analysis settings instead of a single one. For example, different customers might like to adopt different algorithms to analyze the software. The configuration service allows users to specify the computation without looking into too many technical details.
- **Remote Attestation Service** enables an end user to verify the running environment on the cloud. To this end, a user is required to post a request to TCWASM and start the remote attestation process. The service sends back a

cryptographic certificate to guarantee that the running environment is indeed as stated (*e.g.*, an AMD SEV) and the image to be loaded and executed is as expected. The certificate can be passed to other parties and they can then confirm the validity of the running environment by checking the certificate. The remote attestation service can be contacted at any time during the execution to generate the certificate as long as it is necessary to do so.

#### 4.2 Trusted Environment

We use AMD SEV as the underlying TEE environment for TCWASM. A cryptography library is included to realize encryption and decryption actions as specified in TCPA based on the set of cryptographic keys provided in AMD SEV. In addition, TCWASM implements a set of APIs to deliver the trusted certificate from AMD SEV to end users, *e.g.*, a verifiable measurement of firmware, disk, memory, *etc*. Due to the portability of AMD SEV, integration with other program analysis engines is straightforward.

#### 4.3 Property Specification and Management

In TCWASM, the agreed set of regulatory properties is stored on a blockchain. Therefore, a majority of nodes in the network will have a consistent view on those properties as they replicate the ledger and states. To this end, TCWASM embeds a blockchain client to interact with the underlying blockchain. In principle, both permissioned and permissionless blockchains can fit in our setting, *e.g.*, Ethereum [53], Fabric [10], *etc*. While the former is more suitable for a relatively stable group of software providers and customers, the latter fits better in an open market where any global participant is allowed to join. The blockchain client can submit

properties provided by users to blockchain in several different ways, *e.g.*, as transaction metadata, as structural storage of smart contracts, *etc.* In cases of dispute (*i.e.*, providers and consumers have conflicting views on properties) which is commonly resulted from forking on the blockchain, TCWASM is able to have a further decision after several blocks and the longest chain can be identified.

Moreover, properties can be defined with both existing or user-defined specification languages, *e.g.*, computation tree logic, linear temporal logic, *etc.* In the preliminary realization of TCPA, we specify safety properties as program assertions, *e.g.*, via `assert` statement. Therefore, the checking of such properties is converted to a reachability problem where an analysis is required to search for a transition that can potentially lead to a unsafe state. As mentioned earlier, it is possible to have multiple types of specifications in TCWASM. Users are allowed to configure which one they will apply for the submitted properties.

#### 4.4 A Formal Framework For Analyzing WASM

We formalize a WASM program  $P := \langle M_0, M_1, \dots, M_n \rangle$  as a group of modules to be deployed, each of which is a tuple  $M := \langle \mathbb{T}, F, T, M, G \rangle$ , where

- $\mathbb{T}$  defines a vector of function types.
- $F := \langle F_0, F_1, \dots, F_n \rangle$  is a collection of functions. For each function  $f \in F$ ,  $f = \langle ft \in \mathbb{T}, L, E \rangle$  comes with a type, a set  $L$  of local variables that are only accessible inside a function and a list  $E$  of expressions. More specifically, expressions in  $E$  are converted to a control flow graph, where a node in the graph is a basic block that includes a sequence of WASM statements and an edge is a jump from one basic block to another.
- $T$  is a table of indexed function references.
- $M$  is a list of memory elements which can be linearly addressed inside a module.
- $G$  is a set of global variables which can be assessed from any function.

The program analysis framework  $A$  that we developed in this work for WASM programs is formalized as a tuple  $A := \langle K_f, K_o, M, SrcMap, Spec \rangle$ , where  $K_f$  and  $K_o$  are stacks of function calls and operands, respectively.  $M$  denotes the set of modules to be analyzed by  $A$ .  $SrcMap$  is a source map which creates a bidirectional link between confidential source code and bytecode of WASM.  $Spec$  is the specification standard of WASM. Moreover, a configuration of  $A$  is abstracted as  $c := \langle pc, src, k_f, k_o, S, P, \mathcal{G} \rangle$ , where

- $pc$  is a program counter that points to the current program location.
- $src$  is a source code pointer which maps from current  $pc$  to the corresponding source code (*e.g.*, at a specific line of code and offset).
- $k_f$  shows the current stack of functions.
- $k_o$  describes the current stack of operands.

- $S := \langle S_0, S_1, \dots, S_n \rangle$  is a tuple containing one state per module. Specifically,  $S_i \in S$  ( $0 \leq i \leq n$ ) is the state for module  $M_i$ , which is a tuple  $\langle m, G, L \rangle$ .  $m$  is a snapshot of memory.  $G$  and  $L$  describe valuation for both global and local variables.
- $P$  is a set of path conditions, each of which is a group of symbolic conditions to enable the exploration of a specific program path.
- $\mathcal{G} = \langle V, E \rangle$  is a semantic graph that describes fundamental program relations. The vertices  $V$  represent variables, *e.g.*, local variable, global variable, *etc.* Edges  $E$  are an abstraction of dependency between variables. In general, we defined two types of dependencies, *i.e.*, data flow and control flow dependency (marked as  $\mapsto$  and  $\mapsto$ ), respectively. For example,  $a \mapsto b$  indicates that the value of  $b$  is dependent on the value of  $a$  (data flow).  $c \mapsto d$  defines a control flow relation where the value of  $c$  is related to the path selection of a control flow therefore affects the value of  $d$ .

As introduced above, the current implementation of program analysis in TCPA is based on symbolic execution. Specifically, the configuration of  $A$  is initialized with a starting module  $M_j$  and function  $f_k$ . The analysis start by examining the statements in this function's body. Given a statement  $e$ , the program analysis framework  $A$  retrieves elements from  $K_o$ , performs computation as specified in the WASM standard, potentially updating memory, local storage, global storage, path conditions and semantic graph. That said, the processing of  $e$  yields a transition of configuration of  $A$ , from the current one  $c := \langle pc, src, k_f, k_o, S, P, \mathcal{G} \rangle$  to a new one  $c'$ . When a program path has been visited, we combine the path conditions with the specified properties for SMT solving and further verifying whether the properties hold or not. This process iterates until a completion criterion for program analysis is realized, *e.g.*, coverage, time, *etc.*

Although symbolic execution is performed on WASM bytecode, it requires fundamental knowledge from the confidential source code. The most obvious information required in TCPA is a source map that links every bit in the bytecode back to source code, and the other way around as well. With a source map, TCPA can provide software producers with understandable results, *e.g.*, a bug is located at a specific line. Moreover, type information at source code level is also important to facilitate program analysis. For example, we would be able to associate memory access with variables in source code with their types.

The analysis framework  $A$  can have different implementations. As Figure 4 shows, we currently use a framework based on symbolic execution but the general design can fit into a wider range of program analysis techniques, *e.g.*, formal verification, automated testing, *etc.*



## 5 Preliminary Evaluation

### 5.1 Benchmark and Evaluation Setup

**Benchmark.** We have conducted a preliminary evaluation of TCWASM. The benchmarks used in the evaluation are shown in Table 1. We used 8 examples from different application domains with 33 web assembly files in total. The size of benchmark files varies from 2KB to 840KB. We also counted the number of WASM instructions in all files, which manifested a relatively large difference across different test cases. The largest one (Zxing) has over 381K instructions, while the smallest (Snake) only includes 528 instructions. The benchmarks and results are publicly available at <http://omitted.for.double-blind-review/>.

**Evaluation Setup.** All the experiments were performed on two environments, *i.e.*, with and without TEE, respectively. The TEE environment was set up on Google Cloud confidential computing platform<sup>1</sup>, which uses the AMD Epyc processor and SEV-ES<sup>2</sup> as the underlying TEE setting. The cloud machine was configured with dual 2.25GHz cores, 8GB memory and a Ubuntu 18.04 operating system. Moreover, the non-TEE environment carried Intel i9 processor with dual 2.3GHz cores, 8GB memory and a Ubuntu 18.04 operating system. All the computation was executed by only one core of the processor in our evaluation.

### 5.2 Evaluation Results

In the evaluation, we ran TCWASM with and without the support of TEE (*i.e.*, AMD SEV in our case) on all benchmarks. For a test file  $f$ , TCWASM performs a systematic program analysis based on symbolic execution [33] to explore the state space of  $f$  and create a semantic abstraction as well. That said, the execution did not include detection of specific types of bugs or errors, as in many existing program analyzers. The goal of this evaluation was to understand the performance trade-off with the design of TCPA, rather than assessing the effectiveness of a certain bug-detection algorithm. With a framework such as TCWASM, the implementation of a detector is a straightforward task even in the context of TCPA.

**Time Overhead.** The time cost with and without a TEE is described in Table 2. In the evaluation, we observed the smallest 7.7% overhead in the case of `tfjs-backend`, while the largest case was 367.5% for `imagequant`. The average time overhead was 139.3% on all benchmark files. For a subset of the test cases, files with larger sizes introduced bigger time overhead as expected. For instance, `binjgb`, `module1`, `avif_dec` led to an increasing level of overhead with a growing size and number of instructions. However, there were exceptions in the evaluation where big files manifested small overheads. For example, in the case of `mozjpeg_enc` (217 KB),

running TCWASM is 95.1% slower than the non-TEE version. For the case of `rotate` (14 KB) which is only 6.5% as large as `mozjpeg_enc`, the overhead was 107.0% that amounts to a relative 12.5% growth. Further discussions on root causes of the overhead can be found below.

**Memory Overhead.** In addition to time cost, we analyzed the memory overhead with TCWASM in our evaluation. Similarly, the analysis was conducted with and without the support of TEE, as shown in Table 3. In general, majority of the overheads were below 45%. More specifically, the overheads for half of the test cases were even less than 8%, which we believe is highly acceptable in practical scenarios. On the other hand, there were two cases that manifested a 2X and 4X overheads, although the actual memory used were not big, *i.e.*, 10.8MB and 36.4MB respectively. The `tfjs-backend` file was particularly interesting due to the fact that TCWASM consumed less memory with a TEE than the non-TEE version. Detailed explanations are given in the following section.

### 5.3 Discussions

We now describe a further discussion on the empirical results with TCWASM to help understand its performance manifested in the evaluation.

**General Explanation.** First of all, the runtime overheads in general introduced by TCWASM in our evaluation are easy to understand. In the case of time overhead, the execution of TCPA protocol was encapsulated in a TEE environment, which encrypts and decrypts memory accessed by the running program, *i.e.*, in our case the TCWASM implementation, therefore should last longer than running TCPA without a TEE (139.3% as described in Table 2), depending on how efficient the TEE is realized. On the other hand, TCWASM did not manifest a higher level of memory consumption than a non-TEE implementation for the majority of test cases used in the evaluation as shown in Table 3, due to the fact that encryption and decryption of memory in a TEE are not memory-intensive procedures thus commonly require little extra memory in running TCPA.

**Special Cases.** Despite the general analysis of evaluation results, we did observe that there were exceptions that seemed not to be consistent with other cases. As shown in Table 2, it was much slower for TCWASM to process `avif_dec`, `imagequant` and `asm-dom` than other test files. The average time overhead for the three is 273.0% which almost doubles the number of total average. As explained above, the time overhead is mainly resulted from encryption and decryption of memory used by TCWASM. More specifically, the overhead is closely correlated to the memory complexity of analysis (*e.g.*, the amount of memory used and the frequency to access it) adopted in the TCPA realization, *i.e.*, a symbolic-execution based analysis. Like many other well-designed symbolic engines, TCWASM uses a variety of specific data structures to store intermediate information of program analysis, *e.g.*,

<sup>1</sup><https://cloud.google.com/confidential-computing>

<sup>2</sup><https://developer.amd.com/sev/>

**Table 1.** Statistics of the benchmark. KB: kilobyte.

Type	Benchmark	File	Size (KB)	#Instruction
Image Processing	Squoosh	module1	224	111,533
		avif_dec	640	152,481
		imagequant	58	26,641
		mozjpeg_enc	217	64,426
		rotate	14	700
		zxing	840	381,368
Machine Learning	Tensorflow	tfjs-backend	222	108,735
Library	C Standard Library	stdio	11	5,156
		string	11	4,664
		memory	16	8,519
Framework	asm-dom	asm-dom	100	44,828
Game	Game Boy	binjgb	98	41604
	Maze	maze	2	780
	Snake	snake	2	528

**Table 2.** Time cost. s: second.

File	TEE (s)	Non-TEE (s)	Overhead
module1	67.7	36.3	85.4%
avif_dec	1,823.6	559.6	225.9%
imagequant	493.0	105.4	367.5%
mozjpeg_enc	659.7	338.2	95.1%
rotate	358.4	173.1	107.0%
zxing	1,427.5	530.4	169.3%
tfjs-backend	712.9	661.1	7.7%
stdio	53.5	20.4	162.3%
string	26.5	10.5	152.4%
memory	117.9	46.0	156.3%
asm-dom	382.5	117.5	225.5%
binjgb	155.5	136.7	13.8%
maze	2.2	1.0	120.0%
snake	0.5	0.3	61.3%
average	*	*	139.3%

**Table 3.** Memory cost. MB: megabyte.

File	TEE (MB)	Non-TEE (MB)	Overhead
module1	6.4	5.7	12.3%
avif_dec	80.2	59.5	34.8%
imagequant	51.2	10.8	374.1%
mozjpeg_enc	78.5	75.9	3.4%
rotate	15.7	14.8	6.1%
zxing	106.0	36.4	191.2%
tfjs-backend	65.4	65.6	-0.3%
stdio	11.7	10.9	7.3%
string	6.1	5.7	7.0%
memory	15.2	14.2	7.0%
asm-dom	52.3	49.4	5.9%
binjgb	20.6	14.2	45.1%
maze	2.8	2.0	40.0%
snake	0.8	0.6	33.3%
average	*	*	54.8%

states of analysis, symbolic contexts, path conditions, *etc.* Particularly, TCWASM introduced a graph-based structure to separate the modeling of a given program and its symbolic execution process. While the advantage of such design is to have better composability via integration with different symbolic execution engines and backend analyzers, it inevitably increases the level of memory consumption and access frequency. Moreover, abnormal time overheads were partially attributed to the evaluation setting as well. We use an illustrative example in Figure 5 to explain the cause.

Figure 5 describes an evaluation setting to cover two paths in the given program and the exploration of each path is bounded within a specified timeout, *e.g.*, one second. Although settings may vary across different program analyzers

to deal with specific use cases, they commonly share similar fundamental parameters, *e.g.*, level of coverage and timeout for SMT solving. In particular, Figure 5 demonstrates a scenario where setting overhead is introduced. Specifically, a program analyzer without TEE (left) manages to cover the first and second paths of a given program and then finishes the analysis without exploring the remaining paths. However, in the case on the right, the program analyzer with TEE (right) manages to cover the first path of a given program, fail at the second and third due to timeouts of SMT solving, and then cover the last. In such cases, although overheads on two visited paths are relatively small, the total overhead becomes much bigger because of unfinished explorations on the other two paths.

**Table 4.** The preliminary performance validation with simple programs.

File	Time (second)			Memory (MB)		
	TEE	Non-TEE	Overhead	TEE	Non-TEE	Overhead
self_addition	14.2	12.5	13.6%	0.7	0.5	40.0%
array_addition	3.6	0.8	350.0%	389.3	389.2	0.03%
quick_sort	134.4	32.4	314.8%	387.4	392.5	-1.3%
constraint_addition	0.4	0.3	33.3%	128.6	128.2	0.3%
constraint_division	5.0	2.6	92.3%	300.1	302.8	-0.9%

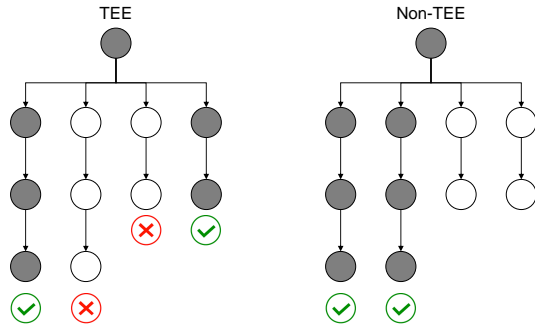
**Figure 5.** An evaluation setting of covering two paths with a specified timeout on each path.

In terms of memory overhead, the evaluation manifested abnormal results as well. Specifically, `imagequant` and `zxing` introduced a large overhead while `tfjs-backend` even showed a negative overhead, *i.e.*, TCWASM was faster than the non-TEE version. Commonly, TCPA does not introduce a high level of memory overhead because the encryption process, *e.g.*, AES as used in our case with AMD SEV, often generates ciphertexts with similar sizes as plaintexts. However, there might be cases as well where ciphertexts are bigger with specific padding strategies. Another factor to potentially affect the measurement of memory overhead is garbage collection in virtual machines. For cases where memory consumption is measured right after a garbage collection process, we might have a much smaller number than expected. Further investigation on such cases is left as future work.

**Preliminary Validation.** Since the implementation of TCWASM is non-trivial, we conducted a preliminary validation with a small group of simple test cases to justify the root cause analysis as described above. The validation is shown in Table 4.

Specifically, the test cases used in the validation included the following programs:

- `self_addition`: increment a variable  $10^7$  times with a specific value
- `array_addition`: add to  $10^7$  elements in a given array
- `quick_sort`: quick sort a given list

- `constraint_addition`: a program with an addition constraint for SMT solving
- `constraint_division`: a program with a division constraint for SMT solving

As shown in the first two rows of Table 4, `self_addition` manifested a relatively lower level of time overhead (13.6%) compared to `array_addition` (350.0%). The gap is resulted from different structures of memory accessed by both programs. While `self_addition` only manipulated a single unit of memory, `array_addition` is allocated with a consecutive memory space therefore each access to it requires addressing with the starting point and the offset. As a result, running `array_addition` with TEE was much slower than without TEE due to encryption of a more complicated memory. In the case of `self_addition`, TEE did not slow down too much of the execution. Furthermore, a similar explanation can apply to `quick_sort`, *i.e.*, the third row of Table 4. Since the memory used by a quick sorting algorithm commonly includes a pivot and sub-lists of a given list, it introduced a high level of time overhead (314.8%) as `array_addition`. Moreover, the last two rows of Table 4 demonstrated two cases with simple and complicated path constraints for SMT solving, respectively. While `constraint_addition` generated a constraint with addition, `constraint_division` was a division constraint. Therefore, it took longer for TCWASM to solve `constraint_division` than `constraint_addition`. As explained in Figure 5, TCWASM managed to solve the division constraint without TEE but failed with TEE due to timeout (which could be verified based on runtime logs). Therefore, the time overhead in the fourth row is larger, *i.e.*, 92.3%. On the other hand, the addition constraint can be solved with and without TEE thus did not manifest a large overhead in the last row. In terms of memory, all cases introduced slight overheads, which can be explained by the fact that the memory encryption process enforced by TEE (*i.e.*, AMD SEV) did not require much extra memory space.

## 6 Related Work

**TEE-based Technology.** The capabilities of TEEs have been widely exploited to achieve security, confidentiality and simplicity in many application domains. In the design of secure systems, Baumann *et al.* proposed the notion of shielded

execution on cloud platforms [6]. Their work addresses the dual challenges of executing unmodified legacy binaries and protecting them from a malicious host. Similar ideas were adopted in data-processing and delegation-based systems to achieve integrity and security without trusting the service providers [32, 37, 47]. Moreover, Tsai *et al.* demonstrated that a fully-featured library operating system can deploy unmodified applications with the support of a TEE [51]. Shen *et al.* further introduced secure and efficient multitasking on top of library operating systems with Intel SGX [49]. In the area of blockchain and cryptocurrency, TEEs are often considered a tool to enable trusted and privacy-preserving transactions. Matetic *et al.* leveraged SGX enclaves to protect privacy of bitcoin light clients [38]. Cheng *et al.* designed a TEE-based blockchain that executes transactions with confidential input, output and states [13]. Other attempts included building asynchronous access [36], allowing real-time cryptocurrency exchange [7], resource-efficient mining [55] and so on. Moreover, TEEs have also been involved in a diverse collection of optimizations on existing software and hardware, *e.g.*, databases [22, 43, 50, 56], network functionalities [20, 29, 42], storage systems [2, 4, 5, 34]. In addition to applications of TEEs, their design has also been the topic on recent papers proposing improvements interoperability [23, 52], performance [35], and resilience [3, 19].

**Program Analysis.** Program analysis has been a mainstream research direction in the programming language community for decades. Formal verification techniques were proposed to verify high-level programs (usually specified in formal modeling languages) against given specifications of target systems, *e.g.*, safety, liveness, *etc.* Clarke *et al.* introduced the technology of model checking to systematically explore the state space of a system and check whether important properties hold or not [15]. Hoare and Roscoe proposed Communicating Sequential Processes (CSP) as a fundamental formalism to model and verify concurrent systems [30, 46]. Alur *et al.* further introduced timed automata to handle timed systems with properties based on temporal logic [1]. In addition to automatic techniques, theorem proving was designed to deliver rigorous verification with manual or semi-automatic proofs [16, 40]. On the other hand, program analysis has also been applied in practical systems with low-level code, *e.g.*, C++, Java, x86 binary, JVM bytecode, *etc.* Based on whether the process requires actually executing a program, the analysis is generally categorized into two classes, *i.e.*, static and dynamic analysis. In the context of static program analysis, a variety of researches have been proposed to address fundamental challenges of programs, *e.g.*, understanding semantics [18], memory modeling [25], interprocedural analysis [31, 45], multithreading [21], *etc.* In contrast, dynamically approaches check programs by instrumenting the code and analyzing it on the fly. Representative types of solutions include fuzzing [12, 26, 44], predictive

analysis [8, 9, 24] and symbolic execution [11, 14, 27]. In general, the TCPA framework proposed in this paper is compatible with well-defined types of program analysis and the combination of them as well.

## 7 Conclusion

In this paper, we have highlighted the trusted and confidential program analysis (TCPA) as a trustless technology to achieve agreed regulatory compliance on software among multiple parties without revealing sensitive information about it. We designed the protocol of TCPA for trusted execution environments and developed TCWASM as the very first implementation of TCPA. In our preliminary evaluation with WASM benchmark files, TCWASM demonstrated the potential to handle complicated cases without incurring too much overhead. Further instantiation of TCPA with new types of program analysis and trusted computing solutions is left for future work. We hope that with the rapid development of new TEEs, there will be convergence on a security model that serves TCPA well. We have shown that on AMD SEV, it is already a serious proposition.

## References

- [1] Rajeev Alur and David L Dill. 1994. A theory of timed automata. *Theoretical computer science* 126, 2 (1994), 183–235.
- [2] Arvind Arasu, Ken Eguro, Raghav Kaushik, Donald Kossmann, Pingfan Meng, Vineet Pandey, and Ravi Ramamurthy. 2017. Concerto: A high concurrency key-value store with integrity. In *Proceedings of the 2017 ACM International Conference on Management of Data*. 251–266.
- [3] Raad Bahmani, Ferdinand Brasser, Ghada Dessouky, Patrick Jauernig, Matthias Klimmek, Ahmad-Reza Sadeghi, and Emmanuel Stapf. 2021. {CURE}: A Security Architecture with Customizable and Resilient Enclaves. In *30th {USENIX} Security Symposium ({USENIX} Security 21)*.
- [4] Maurice Bailleu, Dimitra Giantsidi, Vasilis Gavrielatos, Vijay Nagarajan, Pramod Bhatotia, et al. 2021. Avocado: A Secure In-Memory Distributed Storage System. In *2021 {USENIX} Annual Technical Conference ({USENIX}{ATC} 21)*. 65–79.
- [5] Maurice Bailleu, Jörg Thalheim, Pramod Bhatotia, Christof Fetzer, Michio Honda, and Kapil Vaswani. 2019. {SPEICHER}: Securing lsm-based key-value stores using shielded execution. In *17th {USENIX} Conference on File and Storage Technologies ({FAST} 19)*. 173–190.
- [6] Andrew Baumann, Marcus Peinado, and Galen Hunt. 2015. Shielding applications from an untrusted cloud with haven. *ACM Transactions on Computer Systems (TOCS)* 33, 3 (2015), 1–26.
- [7] Iddo Bentov, Yan Ji, Fan Zhang, Lorenz Breidenbach, Philip Daian, and Ari Juels. 2019. Tesseract: Real-time cryptocurrency exchange using trusted hardware. In *Proceedings of the 2019 ACM SIGSAC Conference on Computer and Communications Security*. 1521–1538.
- [8] Michael D Bond, Katherine E Coons, and Kathryn S McKinley. 2010. Pacer: Proportional detection of data races. *ACM Sigplan Notices* 45, 6 (2010), 255–268.
- [9] Sebastian Burckhardt, Pravesh Kothari, Madanlal Musuvathi, and Santosh Nagarakatte. 2010. A randomized scheduler with probabilistic guarantees of finding bugs. *ACM SIGARCH Computer Architecture News* 38, 1 (2010), 167–178.
- [10] Christian Cachin et al. 2016. Architecture of the hyperledger blockchain fabric. In *Workshop on distributed cryptocurrencies and consensus ledgers*, Vol. 310. Chicago, IL.

- [11] Cristian Cadar, Daniel Dunbar, Dawson R Engler, et al. 2008. Klee: unassisted and automatic generation of high-coverage tests for complex systems programs. In *OSDI*, Vol. 8. 209–224.
- [12] Peng Chen and Hao Chen. 2018. Angora: Efficient fuzzing by principled search. In *2018 IEEE Symposium on Security and Privacy (SP)*. IEEE, 711–725.
- [13] Raymond Cheng, Fan Zhang, Jernej Kos, Warren He, Nicholas Hynes, Noah Johnson, Ari Juels, Andrew Miller, and Dawn Song. 2019. Ekiden: A platform for confidentiality-preserving, trustworthy, and performant smart contracts. In *2019 IEEE European Symposium on Security and Privacy (EuroS&P)*. IEEE, 185–200.
- [14] Vitaly Chipounov, Volodymyr Kuznetsov, and George Candea. 2011. S2E: A platform for in-vivo multi-path analysis of software systems. *Acm Sigplan Notices* 46, 3 (2011), 265–278.
- [15] Edmund M Clarke, E Allen Emerson, and Joseph Sifakis. 2009. Model checking: algorithmic verification and debugging. *Commun. ACM* 52, 11 (2009), 74–84.
- [16] Thierry Coquand and Gérard Huet. 1986. *The calculus of constructions*. Ph.D. Dissertation. INRIA.
- [17] Victor Costan and Srinivas Devadas. 2016. Intel sgx explained. *IACR Cryptol. ePrint Arch.* 2016, 86 (2016), 1–118.
- [18] Patrick Cousot and Radhia Cousot. 1977. Abstract interpretation: a unified lattice model for static analysis of programs by construction or approximation of fixpoints. In *Proceedings of the 4th ACM SIGACT-SIGPLAN symposium on Principles of programming languages*. 238–252.
- [19] Ghada Dessouky, Tommaso Frassetto, and Ahmad-Reza Sadeghi. 2020. HybCache: Hybrid side-channel-resilient caches for trusted execution environments. In *29th {USENIX} Security Symposium ({USENIX} Security 20)*. 451–468.
- [20] Huayi Duan, Cong Wang, Xingliang Yuan, Yajin Zhou, Qian Wang, and Kui Ren. 2019. LightBox: Full-stack protected stateful middlebox at lightning speed. In *Proceedings of the 2019 ACM SIGSAC Conference on Computer and Communications Security*. 2351–2367.
- [21] Dawson Engler and Ken Ashcraft. 2003. RacerX: Effective, static detection of race conditions and deadlocks. *ACM SIGOPS operating systems review* 37, 5 (2003), 237–252.
- [22] Saba Eskandarian and Matei Zaharia. 2017. Oblidb: Oblivious query processing for secure databases. *arXiv preprint arXiv:1710.00458* (2017).
- [23] Qian Feng, Rundong Zhou, Chengcheng Xu, Yao Cheng, Brian Testa, and Heng Yin. 2016. Scalable graph-based bug search for firmware images. In *Proceedings of the 2016 ACM SIGSAC Conference on Computer and Communications Security*. ACM, 480–491.
- [24] Cormac Flanagan and Stephen N Freund. 2009. FastTrack: efficient and precise dynamic race detection. *ACM Sigplan Notices* 44, 6 (2009), 121–133.
- [25] Cormac Flanagan, K Rustan M Leino, Mark Lillibridge, Greg Nelson, James B Saxe, and Raymie Stata. 2002. Extended static checking for Java. In *Proceedings of the ACM SIGPLAN 2002 Conference on Programming language design and implementation*. 234–245.
- [26] Patrice Godefroid, Adam Kiezun, and Michael Y Levin. 2008. Grammar-based whitebox fuzzing. In *Proceedings of the 29th ACM SIGPLAN Conference on Programming Language Design and Implementation*. 206–215.
- [27] Patrice Godefroid, Michael Y Levin, and David Molnar. 2012. SAGE: whitebox fuzzing for security testing. *Commun. ACM* 55, 3 (2012), 40–44.
- [28] TC Group et al. 2013. Trusted platform module library specification (tpm2.0).
- [29] Stephen Herwig, Christina Garman, and Dave Levin. 2020. Achieving keyless cdns with conclaves. In *29th {USENIX} Security Symposium ({USENIX} Security 20)*. 735–751.
- [30] Charles Antony Richard Hoare. 1978. Communicating sequential processes. *Commun. ACM* 21, 8 (1978), 666–677.
- [31] Susan Horwitz, Thomas Reps, and David Binkley. 1990. Interprocedural slicing using dependence graphs. *ACM Transactions on Programming Languages and Systems (TOPLAS)* 12, 1 (1990), 26–60.
- [32] Tyler Hunt, Zhiting Zhu, Yuanzhong Xu, Simon Peter, and Emmett Witchel. 2018. Ryoan: A distributed sandbox for untrusted computation on secret data. *ACM Transactions on Computer Systems (TOCS)* 35, 4 (2018), 1–32.
- [33] James C King. 1976. Symbolic execution and program testing. *Commun. ACM* 19, 7 (1976), 385–394.
- [34] Robert Krahn, Bohdan Trach, Anjo Vahldiek-Oberwagner, Thomas Knauth, Pramod Bhatotia, and Christof Fetzer. 2018. Pesos: Policy enhanced secure object store. In *Proceedings of the Thirteenth EuroSys Conference*. 1–17.
- [35] Mingyu Li, Yubin Xia, and Haibo Chen. 2021. Confidential serverless made efficient with plug-in enclaves. In *Proceedings of the 48th International Symposium on Computer Architecture, ISCA*. 14–19.
- [36] Joshua Lind, Oded Naor, Ittay Eyal, Florian Kelbert, Emin Gün Sirer, and Peter Pietzuch. 2019. Teechain: a secure payment network with asynchronous blockchain access. In *Proceedings of the 27th ACM Symposium on Operating Systems Principles*. 63–79.
- [37] Sinisa Matetic, Moritz Schneider, Andrew Miller, Ari Juels, and Srdjan Capkun. 2018. DeleGate: Brokered delegation using trusted execution environments. In *27th {USENIX} Security Symposium ({USENIX} Security 18)*. 1387–1403.
- [38] Sinisa Matetic, Karl Wüst, Moritz Schneider, Kari Kostiaainen, Ghassan Karame, and Srdjan Capkun. 2019. {BITE}: Bitcoin lightweight client privacy using trusted execution. In *28th {USENIX} Security Symposium ({USENIX} Security 19)*. 783–800.
- [39] Chris Mitchell. 2005. *Trusted computing*. Vol. 6. Iet.
- [40] Tobias Nipkow, Lawrence C Paulson, and Markus Wenzel. 2002. *Isabelle/HOL: a proof assistant for higher-order logic*. Vol. 2283. Springer Science & Business Media.
- [41] Sandro Pinto and Nuno Santos. 2019. Demystifying arm trustzone: A comprehensive survey. *ACM Computing Surveys (CSUR)* 51, 6 (2019), 1–36.
- [42] Rishabh Poddar, Chang Lan, Raluca Ada Popa, and Sylvia Ratnasamy. 2018. Safebricks: Shielding network functions in the cloud. In *15th {USENIX} Symposium on Networked Systems Design and Implementation ({NSDI} 18)*. 201–216.
- [43] Christian Priebe, Kapil Vaswani, and Manuel Costa. 2018. EnclaveDB: A secure database using SGX. In *2018 IEEE Symposium on Security and Privacy (SP)*. IEEE, 264–278.
- [44] Sanjay Rawat, Vivek Jain, Ashish Kumar, Lucian Cojocar, Cristiano Giuffrida, and Herbert Bos. 2017. VUZZer: Application-aware Evolutionary Fuzzing. In *NDSS*, Vol. 17. 1–14.
- [45] Thomas Reps, Susan Horwitz, and Mooly Sagiv. 1995. Precise interprocedural dataflow analysis via graph reachability. In *Proceedings of the 22nd ACM SIGPLAN-SIGACT symposium on Principles of programming languages*. 49–61.
- [46] Bill Roscoe. 1998. *The theory and practice of concurrency*. (1998).
- [47] Moritz Schneider, Sinisa Matetic, Ari Juels, Andrew Miller, and Srdjan Capkun. 2019. Secure Brokered Delegation Through DeleGate. *IEEE Security & Privacy* 17, 4 (2019), 43–52.
- [48] AMD SEV-SNP. 2020. Strengthening VM isolation with integrity protection and more. *White Paper, January* (2020).
- [49] Youren Shen, Hongliang Tian, Yu Chen, Kang Chen, Runji Wang, Yi Xu, Yubin Xia, and Shoumeng Yan. 2020. Occlum: Secure and efficient multitasking inside a single enclave of intel sgx. In *Proceedings of the Twenty-Fifth International Conference on Architectural Support for Programming Languages and Operating Systems*. 955–970.
- [50] Yuanyuan Sun, Sheng Wang, Huorong Li, and Feifei Li. 2021. Building enclave-native storage engines for practical encrypted databases. *Proceedings of the VLDB Endowment* 14, 6 (2021), 1019–1032.

- [51] Chia-Che Tsai, Donald E Porter, and Mona Vij. 2017. Graphene-sgx: A practical library {OS} for unmodified applications on {SGX}. In *2017 {USENIX} Annual Technical Conference ({USENIX} {ATC} 17)*. 645–658.
- [52] Samuel Weiser, Mario Werner, Ferdinand Brasser, Maja Malenko, Stefan Mangard, and Ahmad-Reza Sadeghi. 2019. TIMBER-V: Tag-Isolated Memory Bringing Fine-grained Enclaves to RISC-V.. In *NDSS*.
- [53] Gavin Wood. 2014. Ethereum: A secure decentralised generalised transaction ledger. *Ethereum Project Yellow Paper* 151 (2014).
- [54] Zhiqiang Yang, Han Liu, Yue Li, Huixuan Zheng, Lei Wang, and Bang-dao Chen. 2020. Seraph: enabling cross-platform security analysis for EVM and WASM smart contracts. In *Proceedings of the ACM/IEEE 42nd International Conference on Software Engineering: Companion Proceedings*. 21–24.
- [55] Fan Zhang, Ittay Eyal, Robert Escriva, Ari Juels, and Robbert Van Renesse. 2017. {REM}: Resource-efficient mining for blockchains. In *26th {USENIX} Security Symposium ({USENIX} Security 17)*. 1427–1444.
- [56] Wenchao Zhou, Yifan Cai, Yanqing Peng, Sheng Wang, Ke Ma, and Feifei Li. 2021. VeriDB: An SGX-based Verifiable Database. In *Proceedings of the 2021 International Conference on Management of Data*. 2182–2194.