

Exploring Memory Access Patterns for Graph Processing Accelerators

Jonas Dann,¹ Daniel Ritter,¹ Holger Fröning²

Abstract: Recent trends in business and technology (e. g., machine learning, social network analysis) benefit from storing and processing growing amounts of graph-structured data in databases and data science platforms. FPGAs as accelerators for graph processing with a customizable memory hierarchy promise solving performance problems caused by inherent irregular memory access patterns on traditional hardware (e. g., CPU). However, developing such hardware accelerators is yet time-consuming and difficult and benchmarking is non-standardized, hindering comprehension of the impact of memory access pattern changes and systematic engineering of graph processing accelerators.

In this work, we propose a simulation environment for the analysis of graph processing accelerators based on simulating their memory access patterns. Further, we evaluate our approach on two state-of-the-art FPGA graph processing accelerators and show *reproducibility*, *comparability*, as well as the shortened development process by an example. Not implementing the cycle-accurate internal data flow on accelerator hardware like FPGAs significantly reduces the implementation time, increases the benchmark parameter transparency, and allows comparison of graph processing approaches.

Keywords: DRAM; FPGA; Graph processing; Irregular memory access patterns; Simulation

1 Introduction

Recently, areas in computer science like machine learning, computational sciences, medical applications, and social network analysis drove a trend to represent, store, and process structured data as graphs [Be19, DRF20]. Consequently, graph processing gained relevance in the fields of non-relational databases and analytics platforms. As a possible solution to the performance problems on traditional hardware (e. g., CPUs) caused by irregular memory accesses and little computational intensity inherent to graph processing [Be19, DRF20, Lu07], FPGA accelerators emerged to enable unique memory access pattern and control flow optimizations [DRF20]. FPGAs, compared to CPUs or GPUs with their fixed memory hierarchy, have custom-usable on-chip memory and logic resources that are not constrained to a predefined architecture. Example 1 illustrates the effect of irregular memory accesses for breadth-first search (BFS) with an edge-centric approach. When not reading sequentially from DRAM, bandwidth degrades quickly [Dr07], due to significant latency introduced by DRAM row switching and partially discarded fetched cache lines.

¹ SAP SE, {firstname.lastname}@sap.com

² Heidelberg University, holger.froening@ziti.uni-heidelberg.de

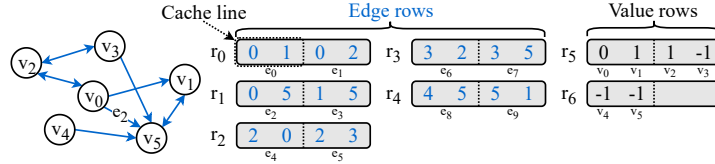

Fig. 1: Illustration of irregular memory accesses for breadth-first search

Example 1. Let each cache line consist of two values, the current BFS iteration be 1 with root v_0 , and e_2 be the current edge to be processed. Figure 1 shows an example graph with a simplified representation in DRAM memory. The graph's edge array is stored in rows r_0 – r_4 and the current value array is stored in r_5 and r_6 . We begin by reading edge e_2 which incurs activating r_1 in the memory and reading a full cache line. Then, we activate r_5 and read the first cache line containing v_0 and v_1 , but only use v_0 . Finally, we activate r_6 to read v_5 and write the new value 1 to the same location, while wasting bandwidth of one value on each request (i. e., reading and not writing the value of v_4).

While FPGA-based graph processing accelerators show good results for irregular memory access pattern acceleration (e. g., [Ya18, Zh19]), programming FPGAs is time-consuming and difficult compared to CPUs and GPUs where the software stack is much better developed [Ab19, BRS13]. Additionally, software developers currently lack the skill-set needed for high-performance FPGA programming, making development even more cumbersome. Aside from that, there are deficiencies in benchmarking of graph processing accelerators due to a large number of FPGAs on the market (almost every article uses a different FPGA), but also lack of accepted benchmark standards (cf. [DRF20]). This leads us to the two main challenges in the field: (1) time-consuming and difficult development of accelerators for irregular memory access patterns of graph processing, (2) differences in hardware platforms and benchmark setups hindering reproduction and comparison.

To solve challenges (1) and (2), we propose a simulation environment for graph processing accelerators (based on the idea in Fig. 2a) as a methodology and tool to quickly reproduce and compare different approaches in a synthetic, fixed environment. On a real FPGA, the on-chip logic implements data flow with on-chip (in block RAM (BRAM)) and off-chip state and graph data in the off-chip DRAM. Based on the observation that the access to DRAM is the dominating factor in graph processing, we however only implement an approximation of the off-chip memory access pattern in our environment working on the graph and state independently of the concrete (difficult to implement) data flow on the FPGA and feed that into a DRAM simulator. While the performance reported by such a simulation may not perfectly match real performance measurements, we see a high potential to better understand graph processing accelerators. This results in the following hypothesis:

Hypothesis. *Memory access patterns dominate the overall runtime of graph processing such that disregarding the internal data flow results in a reasonable error of a simulation.*

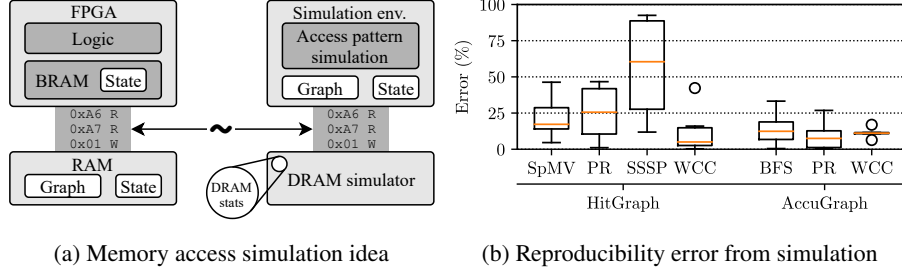

Fig. 2: Graph processing memory simulation idea and achieved reproducibility error

The simulation approach significantly reduces the time to test new graph processing accelerator approaches and also enables design support and deeper inspection with DRAM statistics as well as easy parameter variation. In a recent survey [DRF20], we found multiple graph processing accelerator approaches (e. g., AccuGraph [Ya18], ForeGraph [Da17], HitGraph [Zh19], and Zhang et al. [ZL18] among others). Based on criteria like reported performance numbers on commodity hardware and sufficient conceptual details, we chose two state-of-the-art systems – namely HitGraph [Zh19] and AccuGraph [Ya18] – with orthogonal approaches representing the currently most relevant approaches, edge- and vertex-centric graph processing, and evaluate our approach on their concepts. Figure 2b shows box plots of the percentage error $e = \frac{100 \times |s-t|}{t}$ we achieve for simulation performance s and ground truth performance t (taken from the respective article) grouped by accelerators and algorithms. Without single-source shortest-paths (SSSP) on HitGraph, we get a reasonable mean of 15.63%. We explain why this single algorithm performs so much worse and why there are outliers for HitGraphs and AccuGraphs weakly-connected components (WCC) in Sect. 4.1. In this work, we make the following contributions:

1. We propose a *simulation environment* for graph processing accelerator engineering and *memory access abstractions* based on our hypothesis.
2. We conduct a *comprehensive reproducibility study* for the two representative graph processing accelerators HitGraph and AccuGraph and uncover deficiencies in performance measurement practices.
3. We show the reduced effort of engineering new ideas with our simulation environment by example of *two novel optimizations to AccuGraph*.

This article is structured as follows. In Sect. 2 we introduce basic concepts of graph processing, FPGA-addressable DRAM, and DRAM simulation. In Sect. 3 we conceptually specify the simulation environment, request flow abstractions, and their application to HitGraph and AccuGraph. In Sect. 4 we reproduce and compare the performance measurements of HitGraph and AccuGraph. We show the engineering benefits of our approach in Sect. 5, before discussing related work in Sect. 6 and concluding in Sect. 7.

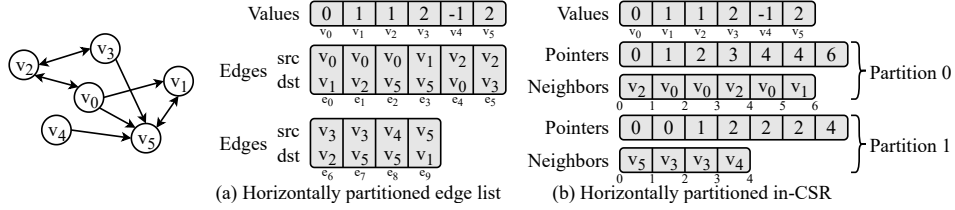

Fig. 3: Graph partitioning and data structures

2 Background

We start this section by briefly specifying graphs, how graph processing can be implemented, and what problems can be solved on graphs. Thereafter, we shortly introduce the memory hierarchy of FPGAs and more specifically how DRAM works internally. Lastly, we motivate the selection of Ramulator [KYM16] as our DRAM simulator and briefly explain how Ramulator models memory and is configured for our purpose.

2.1 Graph Processing

A graph $G = (V, E)$ is an abstract data structure consisting of a vertex set V and an edge set $E \subseteq V \times V$. Intuitively, they are used to describe a set of entities (vertices) and their relations (edges). Figure 3 shows two possible data structure representations (both with two partitions) of the example graph. Horizontally partitioned means dividing up the vertex set of the graph and assigning the edges to the partition containing their source vertex. Figure 3a shows the example graph as a horizontally partitioned edge list (used by HitGraph [Zh19]), which stores the graph as arrays of edges. Figure 3b shows the same graph as a horizontally partitioned compressed sparse row (CSR) format of the inverted edges (used by AccuGraph [Ya18]). The values of the pointers array at position i and $i + 1$ delimit the neighbors of v_i . For example, for v_5 in partition 1 the neighbors are the values of the neighbors array between 2 and 4, i. e., v_3 and v_4 .

Depending on the underlying graph data structure, graphs are processed based on two fundamentally different approaches: edge- and vertex-centric graph processing. Edge-centric systems (e. g., HitGraph) iterate over the edges as primitives of the graph on an underlying edge list. Vertex-centric systems iterate over the vertices and their neighbors as primitives of the graph on an underlying adjacency list (e. g., CSR). For the vertex-centric approach there further is a distinction into push- and pull-based data flow. A push-based data flow denotes that values are pushed along the forward direction of edges to update neighboring vertices. A pull-based data flow (e. g., applied by AccuGraph) denotes that values are pulled along the inverse direction of edges from neighboring vertices to update the current vertex.

In the context of this article, we consider the five graph problems implemented by HitGraph and AccuGraph: BFS, SSSP, WCC, sparse matrix-vector multiplication (SpMV), and PageRank (PR). The problems specify their implementations to varying degrees. For

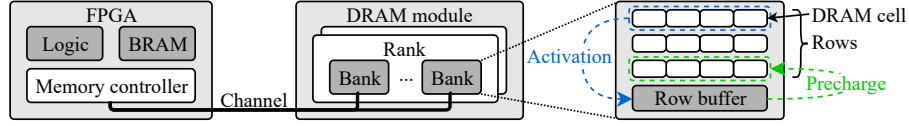

Fig. 4: DRAM (adapted from [KYM16])

example, BFS denotes a sequence of visiting the vertices of a graph. Starting with a root vertex as the frontier, in each iteration, every unvisited neighbor of the current frontier vertices is marked as visited, assigned the current iteration as its value, and added to the frontier of the next iteration.

In contrast, SSSP only specifies the desired output, i. e., for each vertex $v \in V$ the shortest distance to the root vertex. The shortest distance equals the smallest sum of edge weights of any path from the root to v . If every edge is assumed to have weight 1, the result is equal to BFS. Similarly, WCC specifies as output for each vertex its affiliation to a weakly-connected component. Two vertices are in the same weakly-connected component if there is an undirected path between them. There is no requirement on how these outputs are generated.

Finally, SpMV and PR specify the execution directive. SpMV multiplies a vector (equal to V) with a matrix (equal to E) in iterations. PR is a measure to describe the importance of vertices in a graph. It is calculated by recursively applying $p(i) = \frac{1-d}{|V|} + \sum_{j \in N_G(i)} \frac{p(j)}{d_G(j)}$ for each $i \in V$ with damping factor d , neighbors N_G and degree d_G .

2.2 Memory Hierarchies of Field Programmable Gate Arrays

As a processor architecture platform, FPGA chips map custom architecture designs (i. e., a set of logic gates and their connection) to a grid of resources (e. g., look-up tables, flip-flops, and block RAM (BRAM)) connected with a programmable interconnection network. The memory hierarchy of FPGAs is split up into on-chip and off-chip memory. On-chip, FPGAs contain BRAM in the form of SRAM memory components. On modern FPGAs, there is about as much BRAM as there is cache on modern CPUs (all cache levels combined), but contrary to the fixed cache hierarchies of CPUs, BRAM is memory finely configurable to the application. For storage of larger data structures, DRAM (e. g., DDR3³ or DDR4⁴) is attached as off-chip memory. Subsequently, we briefly introduce the internal structure of DDR3 and DDR4 to understand its implications on graph processing.

The internal organization of DDR3 memory is shown in Fig. 4, which at the lowest level contains DRAM cells each representing one bit. The smallest number of DRAM cells (e. g., 16) that is addressable is called a column. Several thousand (e. g., 1,024) columns are grouped together into rows. Further, independently operating banks combine several thousand (e. g., 65,536) rows with a row buffer each.

³ JESD79-3 DDR3 SDRAM Standard

⁴ JESD79-4 DDR4 SDRAM Standard

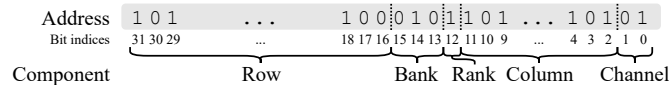

Fig. 5: DRAM addressing

Requests to data in a bank are served by the row buffer based on three scenarios: (1) When the addressed row is already buffered, the request is served with low latency (e. g., t_{CL} : 11ns). (2) If the row buffer is empty, the addressed row is first activated (e. g., t_{RCD} : 11ns), which loads it into the row buffer, and then the request is served. (3) However, if the row buffer currently contains a different row from a previous request, the current row has to be first pre-charged (e. g., t_{RP} : 11ns) and only then the addressed row can be activated and the request served. Additionally, there is a minimum latency between switching rows (e. g., t_{RAS} : 28ns). Thus, for high performance, row switching should be minimized.

Since one bank does not provide sufficient bandwidth, 8 parallel banks further form a rank. Multiple ranks operate in parallel but on the same I/O pins, thus increasing capacity of the memory, but not bandwidth. Finally, the ranks of the memory are grouped into channels. Each channel has its own I/O pins to the FPGA such that the bandwidth linearly increases with the number of channels. DDR4 contains another hierarchy level called bank groups, which group two to four banks to allow for more rapid processing of commands.

Data in DRAM is accessed by giving the memory a physical memory address that is split up into multiple parts internally representing addresses for each component in the DRAM hierarchy (cf. Fig. 5). Based on this, different addressing schemes are possible. An example addressing scheme that aids distribution of requests over channels might first address the channels, meaning subsequent addresses go to different channels, then address columns, ranks, banks, and rows. To further improve memory bandwidth, modern DRAM returns multiple bursts of data for each request (also called prefetching). For DDR3 and DDR4, each request returns a total of 64 Bytes over 8 cycles which we call a cache line in the following.

2.3 DRAM Simulators – Ramulator

To speed up the engineering of graph processing on FPGA accelerators, a DRAM Simulator is an integral part of our simulation environment (cf. Fig. 2a). For our purposes we need a DRAM simulator that supports DDR3 (for HitGraph [Zh19]) and DDR4 (for AccuGraph [Ya18]). We chose Ramulator [KYM16] for this work over other alternatives like DRAMSim2 [RCJ11] and USIMM [Ch12] because – to the best of our knowledge – it is the only DRAM simulator which supports (among many others like LPDDR3/4 and HBM) both of those DRAM standards (DDR3/4).

Ramulator models DRAM as a tree of state machines (e. g., channel, rank, bank in DDR3) where transitions are triggered by user or internal commands. However, Ramulator does not make any assumptions about data in memory. Purely the request and response flow is modelled with requests flowing into Ramulator and responses being called back. The

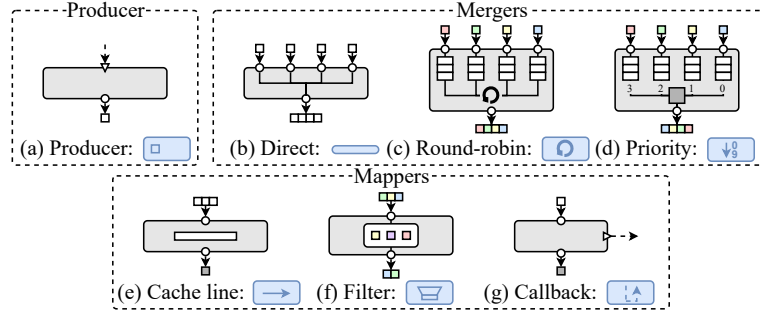

Fig. 6: Memory access abstractions

Ramulator configuration parameters that are relevant to our work are: (1) DRAM standard, (2) channel count, (3) rank count, (4) DRAM speed specification, (5) DRAM organization.

3 Memory Access Simulation Environment

In this section, we first introduce the simulation environment based on the implications of our hypothesis and show the abstractions we developed to implement memory access patterns. Thereafter, we show how this can be applied to real graph processing accelerators. As motivated in Sect. 1, we chose HitGraph [Zh19] and AccuGraph [Ya18] for that.

3.1 Simulation Environment

As we established in Sect. 1, one of the main challenges with evaluating new graph processing ideas on FPGAs is time-consuming and difficult development of the accelerator. Thus, the goal of our simulation environment is reducing development time and complexity within reasonable error when compared to performance measurements on hardware. To achieve this goal we relax the necessity of cycle accurate simulation of on-chip data flow due to our hypothesis: *Memory access patterns dominate the overall runtime of graph processing such that disregarding the internal data flow results in a reasonable error of a simulation.* Modelling the off-chip memory access pattern means modelling request types, request addressing, request amount, and request ordering. Request type modelling is trivial since it is clear when requests read and write data. For request addressing, we assume that the different data structures (e. g., edge list and vertex values) lie adjacent in memory as plain arrays. We generate memory addresses according to this memory layout and the width of the arrays types in Bytes. Request amount modelling is mostly based on the size n of the vertex set, the size m of the edge set, average degree deg , and partition number p . We only simulate request ordering through mandatory control flow caused by data dependencies of requests. We assume that computations and on-chip memory accesses are instantaneous by default. In the following we introduce memory abstractions we developed for modelling request and control flow. Figure 6 shows an overview of the memory access abstractions and their icons grouped by their role during memory access as *producer*, *merger*, and *mapper*.

Producer At the start of each request stream, a *producer* (Fig. 6a) is used to turn control flow (dashed arrow) triggers into a request stream (solid arrow). The producer might be rate limited, but if only a single producer is working at a time or requests are load balanced down-stream, the requests are just created in bulk.

Mergers Multiple request streams might then be merged with *mergers*, since Ramulator only has one endpoint. We have deduced abstractions to merge requests in a *direct* (Fig. 6b), *round-robin* (Fig. 6c), and *priority*-based (Fig. 6d) fashion. If there are multiple request streams that do not operate in parallel, direct merging is applied. If request streams should be equally load-balanced, round-robin merging is applied. If request streams should take precedence over each other, priority merging is applied. For this, a priority is assigned to each request stream and requests are merged based on that.

Mappers Additionally to request creation with producers and ordering with mergers, we also found abstractions for request *mappers*. Thus, we introduce *cache line* buffers (Fig. 6e) for sequential or semi-sequential accesses that merge subsequent requests to the same cache line into one request. We do buffering such that multiple concurrent streams of requests benefit from it independently by placing it as far from the memory as necessary to merge the most requests. For data structures that are placed partially in on-chip memory (e. g., prefetch buffers and caches), and thus partially not require off-chip memory requests, we introduce request *filters* (Fig. 6f) that discard filtered requests. For control flow, we use a *callback* (Fig. 6g) abstraction. We disregard any delays in control flow propagation and just directly let the memory call back into the simulation. If requests are served from a cache line or filter abstraction, the callback is executed, if it is present.

In our simulation environment we instantiate a graph processing simulation and a Ramulator instance, and tick them according to their respective clock frequency. For graph processing simulation we focus on configurability of all aspects of the simulation such that we can quickly run differently parameterized performance measurements. Our simulation works on multiple request streams that are merged into one and fed into Ramulator. This leads us to a immensely reduced implementation time and complexity, gives us more insight into the systems, and provides portability of ideas developed in the simulation environment.

3.2 HitGraph

HitGraph [Zh19] is an edge-centric graph processing accelerator that claims to be among the best performing systems. The basic idea is to partition the graph horizontally into p partitions, stored as edge lists (cf. Sect. 2.1), and process the partitions in two phases in each iteration. First, updates are produced for each edge in each partition in the scatter phase. Second, all updates are applied to their respective vertex for each partition in the gather phase. The main goal behind this approach is to completely eliminate random reads to data and largely reduce the amount of random writes such that only semi-random writes remain. All reads to values of vertices are served from the prefetched partition in BRAM and all reads to either edges or updates are sequential. Writing updates is sequential, while writing values is the only semi-random memory access. Figure 7 shows the request and control flow

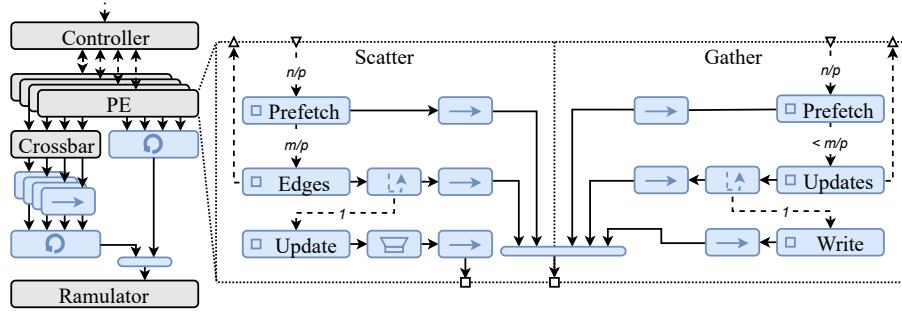

Fig. 7: HitGraph request and control flow

modelling with our simulation environment. Execution starts with triggering a controller that itself triggers iterations of edge-centric processing until there were no changes to vertex values in the previous iteration. In each iteration, the controller first schedules all partitions for the scatter phase, before scheduling all partitions to the gather phase. Partitions are assigned beforehand to channels of the memory (four channels in [Zh19]) and there is a processing element (PE) for each channel. After all partitions are finished in the gather phase, the next iteration is started or the accelerator terminates.

Scatter The scatter phase starts by prefetching the $\frac{n}{p}$ values of the current partition into BRAM. Those requests go to a cache line abstraction, such that requests to the same cache line do not result in multiple requests to Ramulator. After all requests are produced, the prefetch step triggers the edge reading step that reads all $\frac{m}{p}$ edges of the partition. This is only an average value since the exact number of edges in a partition might vary because of skewed vertex degrees. For each edge request, we attach a callback that triggers producing an update request and merge them with a cache line abstraction. The update requests might be filtered by an optimization resulting in less than one update per edge. The target address depends on its destination vertex that can be part of any of the p partitions. Thus, there is a crossbar that routes each update request to a cache line abstraction for each partition, which sequentially writes it into a partition-specific update queue. After all edges have been read, the edge reader triggers the controller, which either triggers the next partition or waits on all memory requests to finish before switching phases.

Gather Similar to scatter, the gather phase starts with prefetching the $\frac{n}{p}$ vertex values sequentially. After value requests have been produced, the prefetcher triggers the update reader, which sequentially reads the update queue written by the scatter phase before. For each update we register a callback that triggers the value write. The value writes are not necessarily sequential, but especially for iterations where a lot of values are written, there might be a lot of locality. Thus, new values are passed through a cache line abstraction.

Parallelization All request streams in each PE are just merged directly into one stream without any specific merging logic, since mostly only one producer is producing requests at a time. However, edge and update reading is rate limited to the number of pipelines in each PE

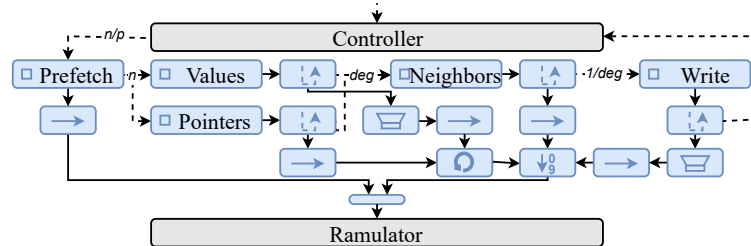

Fig. 8: AccuGraph request and control flow

(which is set to 8 in the original article). Since all PEs are working on independent channels and Ramulator only offers one endpoint for all channels combined, we employ a round robin merge of the PE requests in order not to starve any channel. In addition, HitGraph applies optimizations to update generation. As a first step, the edges are sorted by destination vertex in each partition. This enables merging updates to the same destination vertex before writing them to memory, reducing the amount of updates u from $u = m$ to $u < n \times p$, and providing locality to the gather phases value writing. As a second optimization, an active bitmap with cardinality n is kept in BRAM that saves for each vertex if its value was changed in the last iteration. This enables update filtering, by filtering out updates from inactive vertices which saves a significant amount of update writes for most algorithm and data set combinations. As a final optimization, partitions with unchanged values or no updates are skipped, which saves time spent for prefetching of values and edge/update reading for some algorithms.

Configuration HitGraph is parameterized with the number of PEs p , pipelines, and the partition size q . The number of PEs is fixed to the number of memory channels because each PE works on exactly one memory channel. The pipeline count is limited by the bandwidth available. Lastly, the partition size is chosen such that $p \times q$ vertices fit into BRAM.

3.3 AccuGraph

AccuGraph [Ya18] is a vertex-centric graph processing accelerator with pull data flow. The basic idea is to partition the graph horizontally, store it as in-CSR data format and pull updates from destination vertices (cf. Sect. 2.1). The original article proposes a flexible accumulator able to merge many updates to vertex values per cycle. Figure 8 shows the request and control flow modelling of AccuGraph. The controller is triggered to start the execution. It iterates over the graph until there are no more changes in the previous iteration. Each iteration triggers processing of all partitions. Partition processing starts with prefetching the $\frac{n}{p}$ source vertex values sequentially. Thereafter, values and pointers of all destination vertices are fetched. The value requests are filtered by the values that are already present in BRAM from the partition prefetching. Pointers are fetched purely sequentially. Those two request streams are merged round robin, because a value is only useful with the associated pointers. For every value fetched in this way, neighbors are read from memory sequentially. Since the neighbors of subsequent vertices are in sequence in CSR, this is fully

| Name | Abbr. | Vertices | Edges | Dir. | Degs. | Avg. | ϕ | SCC |
|--------------|-------|------------|---------------|------|-------|-------|--------|-------|
| live-journal | lj | 4,847,571 | 68,993,773 | 👍 | | 14.23 | 16 | 0.790 |
| wiki-talk | wt | 2,394,385 | 5,021,410 | 👍 | | 2.10 | 11 | 0.047 |
| twitter | tw | 41,652,230 | 1,468,364,884 | 👍 | | 35.25 | 75 | 0.804 |
| rmat-24-16 | r24 | 16,777,216 | 268,435,456 | 👍 | | 16.00 | 19 | 0.023 |
| rmat-21-86 | r21 | 2,097,152 | 180,355,072 | 👍 | | 86.00 | 14 | 0.103 |
| roadnet-ca | rd | 1,971,281 | 2,766,607 | 👎 | | 2.81 | 849 | 0.993 |
| berk-stan | bk | 685,231 | 7,600,595 | 👍 | | 11.09 | 514 | 0.489 |
| orkut | or | 3,072,627 | 117,185,083 | 👎 | | 76.28 | 9 | 1.000 |
| youtube | yt | 1,157,828 | 2,987,624 | 👎 | | 5.16 | 20 | 0.980 |
| dblp | db | 425,957 | 1,049,866 | 👎 | | 4.93 | 21 | 0.744 |
| slashdot | sd | 82,168 | 948,464 | 👍 | | 11.54 | 13 | 0.868 |

Abbr.: Abbreviation; Dir.: Directed; Degs.: Degree distribution on log. scale; Avg.: Average degree; ϕ : Diameter; SCC: Ratio of vertices in the largest strongly-connected component to n ; 👍: yes, 👎: no

Tab. 1: Graph data sets used by HitGraph and AccuGraph

sequential. An internal accumulator collects the changes caused through the neighbors and writes them back to memory, when all neighbors were read. The value changes are also directly applied to the values currently present in BRAM for a coherent view of vertex values. This is filtered such that only values that changed are written. All of these request streams are merged by priority, with write request taking the highest priority and neighbors the second highest because otherwise the computation pipelines would be starved. Additionally, we rate-limit neighbors loading to the number of edge pipelines present in the accelerator.

Configuration AccuGraph is parameterized by the number of vertex and edge pipelines (8 and 16 in the original article) and the partition size. The original article also describes an FPGA-internal data flow optimization which allows to approximate pipeline stalls, improving simulation accuracy significantly. The vertex cache used for the prefetched values is partitioned into 16 memory banks on the FPGA which can each serve one vertex value request per clock cycle. Since there are 16 edge pipelines in a standard deployment of AccuGraph, performance deteriorates quickly, when there are stalls. Thus, we implement stalls of this vertex cache in the control flow between the neighbors and write producers. A neighbors request callback is delayed until the memory bank can serve the value request.

4 Evaluation

In this section, we validate our simulation approach by reproducing the results reported for HitGraph [Zh19] and AccuGraph [Ya18], by indeed showing a reasonable simulation error compared to the measurements on real FPGA hardware. In addition, we illustrate for the first time, how these completely different graph processing approaches can be compared.

We take the same data sets (Table 1) and graph problems reported in the original articles to replicate their experiments. Only the two data sets live-journal and wiki-talk are used in both articles. HitGraph also measured performance on high diameter, constant degree graphs

| Approach | Type | Channels | Ranks | Speed | Organization |
|---------------|------|----------|-------|-------|--------------|
| HitGraph | DDR3 | 4 | 2 | 1600K | 8Gb_x16 |
| AccuGraph | DDR4 | 1 | 1 | 2400R | 4Gb_x16 |
| Comparability | DDR4 | 1 | 1 | 2400R | 8Gb_x16 |

Tab. 2: DRAM configurations

| Approach | Weighted | SpMV | SSSP | PR | WCC | BFS | Vertex | Pointer |
|---------------|----------|------|------|----|-----|-----|--------|---------|
| HitGraph | ☑ | 32 | 32 | 32 | 32 | - | 32 | - |
| AccuGraph | ☒ | - | - | 32 | 32 | 8 | 32 | 32 |
| Comparability | ☒ | - | 32 | 32 | 32 | 32 | 32 | 32 |

Tab. 3: Data structure configurations (type width in bits)

| Approach | PEs | Pipelines | Elements | Vertex pipelines | Edge pipelines | VS | ES |
|---------------|-----|-----------|-----------|------------------|----------------|----|----|
| HitGraph | 4 | 8 | 256,000 | - | - | - | - |
| AccuGraph | - | - | ∞ | 8 | 16 | 8 | 8 |
| Comparability | 1 | 16 | 1,024,000 | 8 | 16 | 8 | 8 |

PEs: Processing elements; VS: Vertex pipeline size; ES: Edge pipeline size

Tab. 4: Parameter configurations

(i. e., roadnet-ca and berk-stan) and two instances of rmat synthetic graphs. AccuGraph measured performance on additional social graphs. Both selections of data sets contain directed graphs, while WCC only yields correct results for undirected graphs. This does not concern our reproducibility measurements but needs to be considered in the future.

4.1 Reproducibility

We measure the quality of the simulation as the percentage error $e = \frac{100 \times |s-t|}{t}$ of the simulation performance measurement s compared against the ground truth t reported by the respective article. The HitGraph numbers are extracted from a table and the AccuGraph numbers are taken from a chart. To reproduce the experiments as closely as possible, we parameterized the simulation environment according to configurations from the original articles. Table 2 shows the memory configurations of the reproducibility studies and the comparability study. Table 3 shows the data structure configurations. HitGraph uses weighted graphs and uniformly wide value types for all problems. AccuGraph uses unweighted graphs and an optimized 8 bits wide unsigned integer for BFS (problematic for constant degree graphs). Table 4 shows the respective graph processing accelerator parameters described in Sect. 3.1 and how they are configured. Both approaches share the partition size as a parameter. For the reproducibility study, AccuGraph is assumed to fit all vertices in BRAM for BFS and only for PR and WCC measurements on live-journal and orkut, the partition size is set to 1,700,000 vertices.

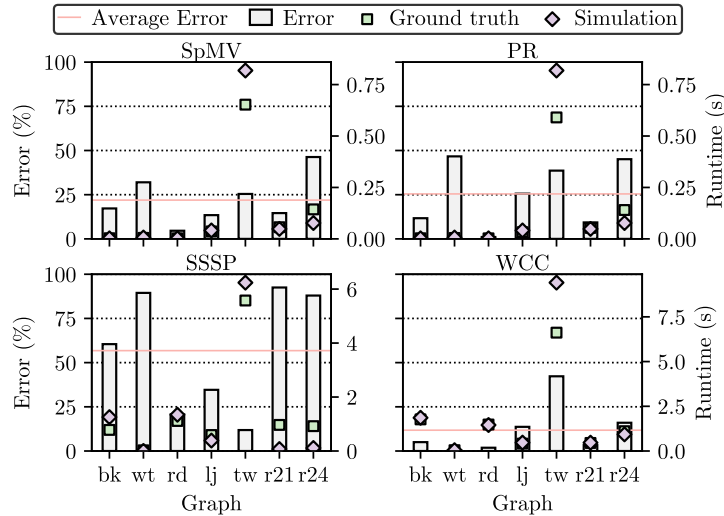

Fig. 9: HitGraph measurements

Figure 9 shows the HitGraph performance measurements for SpMV, PR, SSSP, and WCC as runtime in seconds. Overall, we observe an outlier in the twitter graph which we cannot explain. SpMV and PR result in the same simulation performance, but since ground truth values are slightly different, we get a different error. The high error for some graphs for those two problems is noise in the measurements because only one iteration with very short runtime is measured in the original article. SSSP shows by far the worst error, with some simulations running much longer and some running significantly shorter. This is explained by the problem’s dependence on the input root vertex. HitGraph claims to randomly choose 20 root vertices and report the average runtime. However, wiki-talk and the rmat graphs have many very small strongly-connected components (cf. Tab. 1) which results in large variation in performance measurements for different root vertices. We found that 20 random root vertices are not enough to stabilize the runtime measurements. We advocate for sharing how roots are picked in the future.⁵ Moreover, the HitGraph article does not specify how edge weights are set in the graph, which can also influence runtimes of SSSP. We initialized all weights to 1. We regard WCC as the most reliable indicator for simulation quality because it does not depend on input variables and runs long enough so fixed overheads are irrelevant. We observe a low simulation error for WCC, which reassures us that the off-chip memory access modelling works well for HitGraph.

Figure 10 shows performance measurements for AccuGraph for BFS, PR, and WCC as billions of read edges per second (GREPS). We calculate REPS as the number of actually read edges $m \times i$ (where i is the number of iterations) divided by the runtime r , which

⁵ We generated the 20 random root vertices with the mt19937 generator in C++ with seed 3483584297.

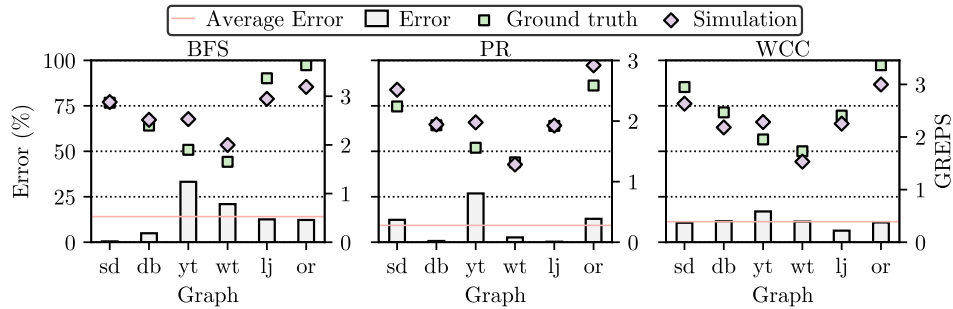

Fig. 10: AccuGraph measurements

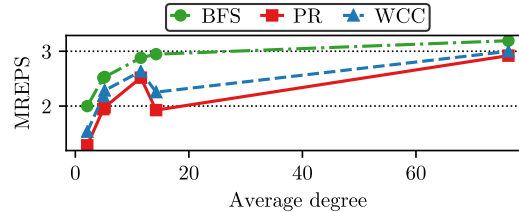

Fig. 11: Performance by average degree

the original article calls traversed edges per second (TEPS). However, this is misleading since the well-known Graph500 benchmark defines TEPS as the number of edges in a graph m divided by the runtime r . Thus, we rename the performance measure to REPS. As we already saw in Fig. 2b, the average error is very similar for all problems and fits the relative performance of the graph data sets well. A noteworthy outlier is the youtube graph which relatively performs better in all simulation measurements than is suggested by the ground truth measurements. The original paper notes that the performance of AccuGraph logarithmically depends on the average degree of vertices which we also reproduced (cf. Fig. 11). Thus, youtube should perform the way our measurements suggest, because it has a slightly higher average degree than the dblp graph. This may be an anomaly in the measurements performed by the AccuGraph authors. WCC is slightly slower in our simulations than they are on the accelerator and PR is slightly faster. There may be a fixed overhead that we are measuring in our experiments and is not measured in theirs. The better performance of PR, however, is expected, since we do not take the longer latencies and incurred pipeline stalls of floating pointer arithmetics into account.

Some outliers and inconsistencies were expected due to not performing a cycle-accurate simulation of the graph processing accelerators. Without SSSP, we see a low mean error of 15.63%. Thus, we confirm our hypothesis: *Memory access patterns dominate the overall runtime of graph processing such that disregarding the internal data flow results in a reasonable error of a simulation.*

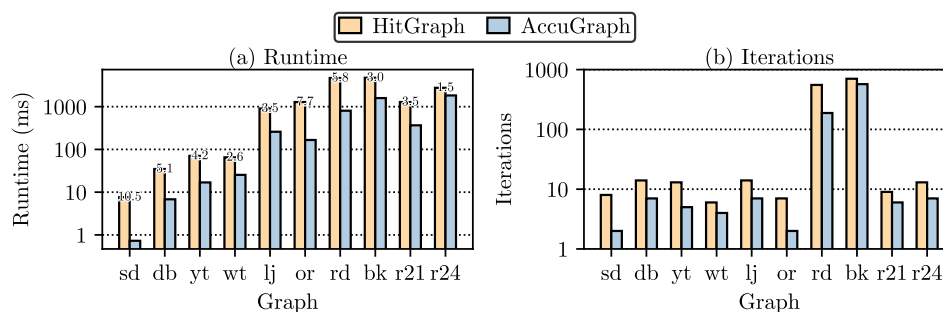

Fig. 12: HitGraph vs. AccuGraph on comparable configurations (with improvement of AccuGraph over HitGraph for runtime)

4.2 Comparability

With these encouraging reproducibility errors and the deeper insight in the approaches configurations, Fig. 12 shows a comparison of HitGraph and AccuGraph on an equal configuration (cf. Comparability in Tab. 2 – Tab. 4). It is not easily possible to use AccuGraph with weighted edges, such that we chose unweighted edges for these measurements. Also it was not possible to expand AccuGraph to use four memory channels, such that we took the AccuGraph DRAM configuration, but increased the memory size to 8GB to be able to accommodate the rmat graphs. However, even this DRAM configuration does not fit the twitter graph which we thus excluded. Moreover, we configured HitGraph to process up to 16 edges each cycle just like AccuGraph and set the partition size to a reasonable 1,024,000 vertices. We show performance numbers of WCC on all graphs used in either of the original articles, since we got the lowest error for WCC. This includes high diameter graphs (e. g., roadnet and berkley-stanford) that AccuGraph has not been tested on yet.

For the two graphs that both systems were originally tested on, AccuGraph (~ 1728 MREPS) reported slightly higher numbers than HitGraph (1665 MREPS) on wiki-talk and HitGraph (3322 MREPS) reported much higher numbers on live-journal than AccuGraph (~ 2406 MREPS) in the original articles. However, this is contrary to the absolute numbers we report here as runtime in seconds (Fig. 12a). HitGraph performs worse on all graphs (the numbers in the runtime chart are the factor calculated by dividing the HitGraph runtime by the AccuGraph runtime). Even the simulation inaccuracy of a mean percentage error of 11.53% for WCC measured in Sect. 4.1 cannot change this. This leads us to a first observation that REPS (used as a performance indicator in the original articles) is not a reliable performance measure due to it hiding differences in runtime.

When comparing the two approaches, we notice that AccuGraph needs fewer iterations for WCC than HitGraph (cf. Fig. 12b). AccuGraph converges on a solution quicker because it updates values directly. Due to the two-staged approach of HitGraph, it always works on the values of the past iteration. Lower iteration count is exhibited especially by measurements

on high average degree, low-diameter graphs (e. g., slash-dot and orkut). Additionally, AccuGraph shows relatively higher performance for small graphs (e. g., slash-dot and dblp). In this scenario, all vertex value reads besides the partition prefetch are served from low-latency, on-chip BRAM, because there is only one partition. The last two factors for AccuGraphs higher performance are: HitGraph needs more requests to read the edges of the graph *and* the updates, and HitGraph reads 64bit per edge while AccuGraph only reads 32bit per edge due to the CSR format. We thus expect a performance advantage of at least factor 2 on all measurements which is not achieved by AccuGraph on the rmat-24-16 graph. This is due to the partition skipping optimization of HitGraph (not available for AccuGraph). This leads to our second observation that AccuGraph has a categorical advantage over HitGraph because of its direct application of value changes and compressed graph format.

4.3 Discussion – Good Benchmarking Practices

We saw that our simulation environment is able to reproduce the ground truth performance measurements of the original articles with reasonable error (Sect. 4.1). We uncovered the pitfalls of graph processing accelerator benchmarking with a comparison of HitGraph and AccuGraph resulting in huge actual differences in runtime (as opposed to similar numbers reported by the original articles) when directly compared on the same set of parameters. Especially if differences in performance of approaches are so significant, an error of 11.53% for WCC is reasonable to make sound comparisons. However, since benchmarking depends on so many configuration parameters, we discuss the different aspects of benchmarking and good benchmarking practice in more detail in the following:

Hardware Almost no two different graph processing accelerator articles use the same hardware due to the huge variety and diversity of devices currently on the market. However, especially comparing absolute performance of systems with very different off-chip memory bandwidth (e. g., single- and multi-channel systems) directly should be avoided. A solution to this might be limiting bandwidth of more potent systems for more equal comparison.

Graph Problems The problems implemented by the HitGraph and AccuGraph articles cover a range of memory access patterns for graph processing. However, very short runtimes due to low number of iterations and not specifying all input data hinder reproducibility of performance measurements. We advocate for running multiple iterations of stationary problems (e. g., PR and SpMV) to improve the signal-to-noise ratio in the measurements. Additionally, we see it as good practice to exactly specify input data (e. g., root vertices and weights) because it can make a large difference on the performance for non-stationary problems like BFS and SSSP. Random input data is not sufficient, if there is no seed available to reproduce it, especially if differences in runtime are large.

Data Sets & Representations For data sets, there should be a broad choice of real world and synthetic small-world graphs, but also graphs with large diameter and small average degree, since these really exaggerate performance issues. Table 1 represents a good set of graphs for benchmarking. One large inconsistency were the representation of the graphs in memory. The data types were not fully disclosed in either of the articles even though they can have a large impact on performance. Additionally, it was not always disclosed

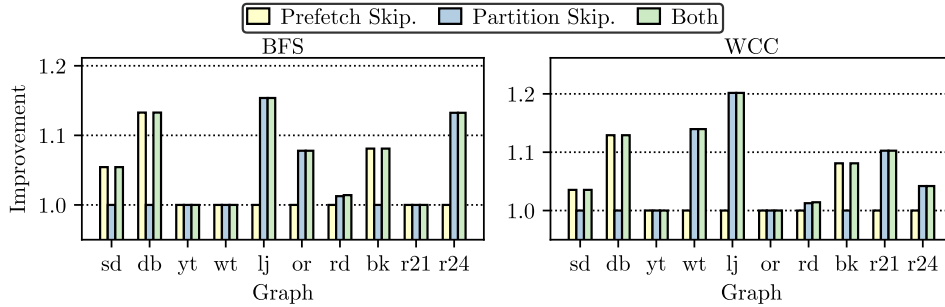

Fig. 13: Runtime improvement of optimizations over baseline

if graphs are regarded as directed or undirected. Using directed graphs as input to WCC (done by both HitGraph and AccuGraph) even yields wrong results. Finally, there is no standard on if graphs should be regarded as weighted or unweighted. Attaching a weight to each edge in the graph further leads to performance differences. We advocate for using the data types shown in Tab. 3, specifying if graphs are directed or undirected (and only using undirected graphs for WCC), and considering weighted graphs, since some problems can only be solved on those (e. g., SpMV and SSSP).

Performance Measures The Graph500 benchmark defines the TEPS performance measure as the number of edges in the graph m divided by the runtime. This is reasonable to normalize performance measurements by graph size. REPS (called TEPS in the original articles) however reports the number of actually read edges divided by the runtime. This only shows how many edges can be read per second, but does not say anything about the efficiency of processing. REPS is a flawed performance measure as it is used currently, since it does not capture the ultimately most important performance indicator: runtime. We thus advocate for always reporting runtime and comparing approaches along that.

5 Example for Faster Graph Accelerator Engineering

In this section, we illustrate how our approach helps to speed up graph processing accelerator engineering by the example of two enhancements of AccuGraph that we found while analyzing the performance in the previous section. Note that instead of implementing the enhancements on the FPGA itself, our simulation approach is used to quickly assess the altered designs for the different data sets as well as potentially different DRAM types, thus reducing the overall engineering time by a form of rapid graph accelerator prototyping.

Enhancement ideas AccuGraph writes all value changes through to off-chip memory and also applies them to BRAM if they are in the current partition. Thus, BRAM and off-chip memory are always in sync. Nevertheless, at the beginning of processing a partition, the value set is prefetched even if the values are already present in BRAM. Thus, the first optimization we propose is prefetch skipping in this case. Especially for the rmat-24-16 graph we also saw the effectiveness of partition skipping with HitGraph (cf. Fig. 12).

Thus as a second optimization, we propose adding partition skipping to AccuGraph. Both optimizations can easily be added to AccuGraphs control flow by directly triggering the value and pointer reading producers or completely skipping triggering of execution for certain partitions respectively. For prefetch skipping we compare the currently fetched partition with the next partition to prefetch and skip prefetching if they are the same. For partition skipping we keep track if any value of the vertices of a partition were changed and skip the partition if none changed. The optimizations also work in combination.

Results To prove their effectiveness, we measure the effect of both optimizations for BFS and WCC separately and combined (Fig. 13). For all small graphs with only one partition we see an improvement based on prefetch skipping. Partition skipping is not applicable to those graphs. For some other graphs we see an improvement based on partition skipping. Prefetch skipping only sometimes contributes a small improvement but only when combined with partition skipping. PR as a stationary algorithm is not shown, since no partitions can be skipped by definition. For prefetch skipping there are similar performance improvements on PR compared to BFS and WCC. Overall we see no decrease in performance, suggesting that both optimizations should always be applied.

Note that these insights on the two enhancement ideas were possible in a relatively short amount of time, compared to engineering on an actual FPGA. However, due to our reproducibility study, the results are transferable to FPGAs.

6 Related Work

To the best of our knowledge, there are no prior works on only using the off-chip memory requests paired with a DRAM simulator to make graph processing accelerators more comprehensible and performance measurements reproducible and comparable.

Comprehensibility [ZCP15] introduces a DRAM model and simulation of what would later become HitGraph. The simulation also generates the sequence of requests, but instead of simulating DRAM runtime, it assumes that every request results in a row buffer hit and models the performance along the cycles needed for processing the data and approximated pipelines stalls. However, they do not show performance numbers generated with this simulation. [Ya19] uses Ramulator as the underlying DRAM simulator for a custom cycle-accurate simulation of the accelerator Graphicionado [Ha16]. However, this incurs very high implementation time.

Reproducibility Regarding reproducibility, there are prior works on ways to report performance results in such a way that it suits the own approach on parallel computing systems [Da95, HB15]. The graph processing accelerator domain seems to suffer from similar problems and lack of widely accepted standards in benchmarking.

Comparability Ramulator [KYM16] was previously used in a work studying the interactions of complex workloads and DRAM types [Gh19]. They uncovered how the internal structure and characteristics of DRAM (DDR3 and DDR4 in our work) relate to performance gains or losses on otherwise fix benchmarks. This may be a future angle to improve graph processing accelerator performance by fitting the DRAM type to the algorithms and data

sets. Similarly to our work, [Xu17] raises awareness to lacking comparability in graph processing approaches, but on CPU-based cloud platforms. They find tradeoffs in approaches between different workloads and differently structured graphs.

7 Discussion and Outlook

In this article, we propose a simulation environment for graph processing accelerator approaches based on our hypothesis: *Memory access patterns dominate the overall runtime of graph processing such that disregarding the internal data flow results in a reasonable error of a simulation.* The simulation environment models request flow fed into a DRAM simulator (i. e., Ramulator [KYM16]) and control flow based on data dependencies. We developed a set of memory access abstractions and applied these to FPGA implementations (i. e., HitGraph [Zh19] and AccuGraph [Ya18]) representing the two dominating graph processing approaches (i. e., edge- and vertex-centric).

Even though the simulation environment disregards large parts of the graph processing accelerator, we showed that it is able to *reproduce* ground truth measurements with a reasonable error (confirming our hypothesis). We further utilized the simulation environment to compare the two approaches on a fixed configuration, revealing insufficiencies in existing performance measurements of graph processing accelerators. Lastly, we show that our simulation approach significantly reduces the time to develop and test graph processing approaches for hardware accelerators by example of two optimizations for AccuGraph that we propose. In addition, our approach allows for deeper inspection with DRAM statistics as well as easy parameter variation without a fixed hardware platform.

In future work, we will extend the approach to an analytical performance model and we will study the relationship of DRAM types, such as HBM, HMC, or LPDDR, as well as further graph processing accelerator approaches in more detail.

References

- [Ab19] Abadi, Daniel; Ailamaki, Anastasia; Andersen, David; Bailis, Peter; Balazinska, Magdalena et al.: The Seattle Report on Database Research. *SIGMOD Rec.*, 48(4):44–53, 2019.
- [Be19] Besta, Maciej; Peter, Emanuel; Gerstenberger, Robert; Fischer, Marc; Podstawski, Michal; Barthels, Claude et al.: Demystifying Graph Databases: Analysis and Taxonomy of Data Organization, System Designs, and Graph Queries. *CoRR*, abs/1910.09017, 2019.
- [BRS13] Bacon, David F.; Rabbah, Rodric M.; Shukla, Sunil: FPGA Programming for the Masses. *ACM Queue*, 11(2):40, 2013.
- [Ch12] Chatterjee, Niladrish; Balasubramonian, Rajeev; Shevgoor, Manjunath; Pugsley, Seth; Udipi, Aniruddha; Shafiee, Ali; Sudan, Kshitij; Awasthi, Manu; Chishti, Zeshan: USIMM: the Utah SImulated Memory Module. University of Utah, Tech. Rep., pp. 1–24, 2012.
- [Da95] Davison, Andrew: Twelve Ways to Fool the Masses When Giving Performance Results on Parallel Computers. pp. 38–42, 1995.

- [Da17] Dai, Guohao; Huang, Tianhao; Chi, Yuze; Xu, Ningyi; Wang, Yu; Yang, Huazhong: ForeGraph: Exploring Large-scale Graph Processing on Multi-FPGA Architecture. In: FPGA. pp. 217–226, 2017.
- [Dr07] Drepper, Ulrich: What Every Programmer Should Know About Memory. Red Hat, Inc, 11, 2007.
- [DRF20] Dann, Jonas; Ritter, Daniel; Fröning, Holger: Non-Relational Databases on FPGAs: Survey, Design Decisions, Challenges. CoRR, abs/2007.07595, 2020.
- [Gh19] Ghose, Saugata; Li, Tianshi; Hajinazar, Nastaran; Cali, Damla Senol; Mutlu, Onur: Demystifying Complex Workload-DRAM Interactions: An Experimental Study. Proc. ACM Meas. Anal. Comput. Syst., 3(3):60:1–60:50, 2019.
- [Ha16] Ham, Tae Jun; Wu, Lisa; Sundaram, Narayanan; Satish, Nadathur; Martonosi, Margaret: Graphicionado: A High-Performance and Energy-Efficient Accelerator for Graph Analytics. In: MICRO. pp. 56:1–56:13, 2016.
- [HB15] Hoefler, Torsten; Belli, Roberto: Scientific Benchmarking of Parallel Computing Systems: Twelve Ways to Tell the Masses When Reporting Performance Results. In: SC. pp. 73:1–73:12, 2015.
- [KYM16] Kim, Yoongu; Yang, Weikun; Mutlu, Onur: Ramulator: A Fast and Extensible DRAM Simulator. IEEE Comput. Archit. Lett., 15(1):45–49, 2016.
- [Lu07] Lumsdaine, Andrew; Gregor, Douglas; Hendrickson, Bruce; Berry, Jonathan: Challenges in Parallel Graph Processing. Parallel Processing Letters, 17(01):5–20, 2007.
- [RCJ11] Rosenfeld, Paul; Cooper-Balis, Elliott; Jacob, Bruce: DRAMSim2: A Cycle Accurate Memory System Simulator. IEEE Comput. Archit. Lett., 10(1):16–19, 2011.
- [Xu17] Xu, Chongchong; Zhou, Jinhong; Lu, Yuntao; Sun, Fan; Gong, Lei; Wang, Chao; Li, Xi; Zhou, Xuehai: Evaluation and Trade-offs of Graph Processing for Cloud Services. In: IEEE ICWS. pp. 420–427, 2017.
- [Ya18] Yao, Pengcheng; Zheng, Long; Liao, Xiaofei; Jin, Hai; He, Bingsheng: An Efficient Graph Accelerator with Parallel Data Conflict Management. In: PACT. pp. 8:1–8:12, 2018.
- [Ya19] Yan, Mingyu; Hu, Xing; Li, Shuangchen; Akgun, Itir; Li, Han; Ma, Xin; Deng, Lei; Ye, Xiaochun; Zhang, Zhimin; Fan, Dongrui; Xie, Yuan: Balancing Memory Accesses for Energy-Efficient Graph Analytics Accelerators. In: ISLPED. pp. 1–6, 2019.
- [ZCP15] Zhou, Shijie; Chelms, Charalampos; Prasanna, Viktor K.: Optimizing memory performance for FPGA implementation of PageRank. In: ReConfig. pp. 1–6, 2015.
- [Zh19] Zhou, Shijie; Kannan, Rajgopal; Prasanna, Viktor K.; Seetharaman, Guna; Wu, Qing: HitGraph: High-throughput Graph Processing Framework on FPGA. IEEE Trans. Parallel Distrib. Syst., 30(10):2249–2264, 2019.
- [ZL18] Zhang, Jialiang; Li, Jing: Degree-aware Hybrid Graph Traversal on FPGA-HMC Platform. In: FPGA. pp. 229–238, 2018.