

Remote Joint Strong Coordination and Reliable Communication

Giulia Cervia, Tobias J. Oechtering, and Mikael Skoglund

School of Electrical Engineering and Computer Science, KTH Royal Institute of Technology, Stockholm, Sweden, {cervia, oech, skoglund}@kth.se

Abstract—We consider a three-node network, in which two agents wish to communicate over a noisy channel, while controlling the distribution observed by a third external agent. We use strong coordination to constrain the distribution, and we provide a complete characterization of the “remote strong coordination and reliable communication” region.

I. INTRODUCTION

Coordination was introduced in [1] as a generalization of traditional information problems, and it is intended as a way to enforce a prescribed behavior and to align statistical information over a network. However, so far there are relatively few results on coordination with security constraints, with the exception of [2], [3] that looked at secure coordination with noiseless links.

In this paper we address for the first time the problem of *remote joint strong coordination and reliable communication* with an outside observer and a noisy channel, which is depicted in Fig. 1. We study a three-node network model comprised of an information source and a noisy channel, in which two agents, an encoder and a decoder, have access to a common source of randomness. Moreover, we consider a third agent, Eve, who observes an output of the noisy channel (possibly different from the decoder’s) but has no knowledge of the common randomness.

We propose a general template problem formulation which presents two different goals: the encoder needs to reliably convey a message to the decoder, while simultaneously forcing Eve’s observation. We can think of two relevant scenarios that can benefit from coordination in this sense. As traditionally in security and privacy, Eve can be a malicious eavesdropper, and, by remotely coordinating her observation, we control what the eavesdropper sees. Then, for example, we can impose perfect secrecy [4], and have the message independent of Eve’s observation. The second possibility is that Eve is not an adversary, but a neighboring receiver, and we want to limit the interference created to Eve by the communication process, as studied for the weaker notion of empirical coordination in [5].

We characterize the remote strong coordination and reliable communication region. Moreover, we are able to characterize the region i) when the distribution that the eavesdropper sees is independent of the message exchanged over the legitimate

channel, ii) when we want to control only the eavesdropper’s marginal distribution.

The rest of the document is organized as follows. Section II introduces the notation, while Section III describes the model under investigation, and states the main results. Finally, the achievability and converse proofs are found in Section IV and Section V respectively.

II. NOTATION

We define the integer interval $\llbracket a, b \rrbracket$ as the set of integers between a and b . Given a random vector $X^n := (X_1, \dots, X_n)$, we denote X^i as the first i components of X^n , and $X_{\sim i}$ as the vector $(X_j)_{j \neq i}$, $j \in \llbracket 1, n \rrbracket$, i.e., X^n without the component X_i . Similarly, we denote $X_{\llbracket 1, m \rrbracket}^n$ as the set of vectors $\{X_s^n | s \in \llbracket 1, m \rrbracket\}$ and $X_{\mathcal{S}}^n$, as the set of vectors $\{X_s^n | s \in \mathcal{S}, \mathcal{S} \subseteq \llbracket 1, m \rrbracket\}$. We indicate with $\mathbb{V}(\cdot, \cdot)$ the *total variation distance* (or *variational distance*) between two distributions. We use $P_A^{\otimes n}$ for the *i.i.d. product distribution* associated with P_A , and Q_A for the *uniform distribution* over \mathcal{A} . We denote with ε a positive infinitesimal quantity which tends to zero as n goes to infinity.

III. SYSTEM MODEL AND MAIN RESULTS

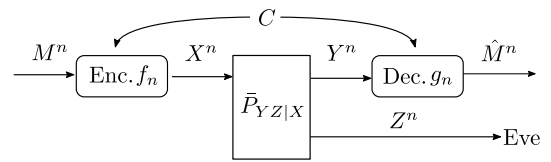

Figure 1. Communication system: a transmitter wants to reliably send a sequence of uniform messages (M_1, \dots, M_n) of total rate R_M over a discrete memoryless channel $\bar{P}_{Y|X}$, while simultaneously controlling the distribution on Z^n seen by Eve.

A. System Model

Suppose we are in the setting of Figure 1. The encoder wants to send a uniform message M^n of rate $R_M = \log K^n/n = \log K$ over a DMC $\bar{P}_{Y|X}$, and encoder and decoder share a source of uniform randomness of rate R_C . We want to think of the message M^n as a sequence of *uniform i.i.d. messages* (M_1, \dots, M_n) , where each M_i is generated uniformly according to the distribution Q_M . To do that, we write the message M^n as the integer $1 + \sum_{i=1}^n (M_i - 1)K^{i-1} \in \llbracket 1, K^n \rrbracket$, which is characterized by the choice of the

This work was supported in part by the Swedish foundation for strategic research and the Swedish research council.

coefficients $M_i \in [1, K]$, and we denote it with $M^n := (M_1, \dots, M_n)$.

The decoder exploits its knowledge of the output of the channel and of common randomness C to estimate correctly the message M^n . At the same time, we want to remotely control the output of the DMC $\bar{P}_{Z|X}$ seen by the eavesdropper Z^n , by having the distribution $P_{Z^n|M^n}$ induced by the code indistinguishable from a target i.i.d. distribution. We formalize these requests in the following definition.

Definition 1: Given a channel $\bar{P}_{Y|Z|X}$, a triple $(\bar{P}_{Z|M}, R_M, R_C)$ is achievable for *remote strong coordination and reliable communication* if there exists a sequence (f_n, g_n) of encoders-decoders with rate of common randomness R_C , such that, for every message M^n ,

$$\lim_{n \rightarrow \infty} \mathbb{V} \left(P_{Z^n|M^n}, \bar{P}_{Z|M}^{\otimes n} \right) = 0, \quad (1a)$$

$$\lim_{n \rightarrow \infty} \mathbb{P} \{ \hat{M}^n \neq M^n \} = 0, \quad (1b)$$

where P_{Z^n} is the joint distribution induced by the source, the channel, and the coordination code. The *remote strong coordination and reliable communication region* \mathcal{R} is the closure of the set of all achievable triples (\bar{P}_Z, R_M, R_C) .

Remark 1: Note that even though we define the message as a sequence of uniform messages, the problem is well-defined. In fact, if one considers a permutation of the message set, the set of achievable triplets does not change.

B. Main Results

In this section, we present the *remote strong coordination and reliable communication* regions, first in the general case and then with secrecy constraints.

1) General Case:

Theorem 1: Let $\bar{P}_{Y|Z|X}$ be the given channel parameter, then

$$\mathcal{R} := \left\{ (\bar{P}_{Z|M}, R_M, R_C) : \begin{array}{l} \bar{P}_{Z|M} = \sum_x P_X \bar{P}_{Z|MX} \\ \exists W \sim \bar{P}_{W|M^n C X Y Z} \text{ such that} \\ W - X - Y Z \\ R_M \leq \max_{P_X} \min \{ I(X; Y); H(XW|Z) \} \\ R_C \geq I(W; Z) - I(W; Y) \\ |\mathcal{W}| \leq |\mathcal{X} \times \mathcal{Y} \times \mathcal{Z}| + 1 \end{array} \right\}. \quad (2)$$

2) *Secrecy constraints:* Suppose we not only wish to control what the decoder sees, by strongly coordinating $P_{Z^n|M^n}$, but we also want to make sure that the message M^n , safely exchanged between the legitimate users, is independent of the observation Z^n :

$$\lim_{n \rightarrow \infty} I(M^n; Z^n) = 0. \quad (3)$$

Then, by adding the strong secrecy condition [6] above to the conditions (1a) and (1b) of Definition 1, the following result derives the coordination region.

Proposition 1: Let $\bar{P}_{Y|Z|X}$ be the given channel parameter, then the following region is the strong coordination region as defined in Definition 1, with the strong secrecy condition (3):

$$\mathcal{R}_{\text{ind}} := \left\{ (\bar{P}_{Z|M}, R_M, R_C) : \begin{array}{l} \bar{P}_{Z|M} = \sum_x P_X \bar{P}_{Z|MX} \\ \exists W \sim \bar{P}_{W|M^n C X Y Z} \text{ such that} \\ W - X - Y Z \\ R_M \leq \max_{P_X} \min \{ I(X; Y), H(X|Z) \} \\ R_C \geq I(W; Z) - I(W; Y) \\ |\mathcal{W}| \leq |\mathcal{X} \times \mathcal{Y} \times \mathcal{Z}| + 1 \end{array} \right\}. \quad (4)$$

C. Control of the marginal distribution

Suppose that, instead of considering $P_{Z^n|M^n}$, we make the weaker demand of controlling the distribution P_{Z^n} observed by the eavesdropper. As we will see, this request has the advantage of having the rate R_M upper bounded only by $I(X; Y)$, allowing the legitimate receiver to exploit the entire capacity of the channel, regardless of the other dependencies between random variables. Then, the set of distributions and rates for which

$$\lim_{n \rightarrow \infty} \mathbb{V} (P_{Z^n}, \bar{P}_Z^{\otimes n}) = 0, \quad (5a)$$

$$\lim_{n \rightarrow \infty} \mathbb{P} \{ \hat{M}^n \neq M^n \} = 0, \quad (5b)$$

is characterized in the following result.

Proposition 2: Let $\bar{P}_{Y|Z|X}$ be the given channel parameter, the capacity region for which (5a) and (5b) hold, is

$$\mathcal{R}_{Z^n} := \left\{ (\bar{P}_Z, R_M, R_C) : \begin{array}{l} \bar{P}_Z = \sum_x P_X \bar{P}_{Z|X} \\ \exists W \sim \bar{P}_{W|M^n C X Y Z} \text{ such that} \\ W - X - Y Z \\ R_M \leq \max_{P_X} I(X; Y) \\ R_C \geq I(W; Z) - I(W; Y) \\ |\mathcal{W}| \leq |\mathcal{X} \times \mathcal{Y} \times \mathcal{Z}| + 1 \end{array} \right\}. \quad (6)$$

Remark 2: Note that \mathcal{R} and \mathcal{R}_{Z^n} do not live in the same space, since the space of probability distributions is different. Hence, one is not contained in the other.

Related work: Note that both the constraint on R_M and the achievable distributions are the same for the empirical coordination region for this setting, derived in [5]. However, strong coordination requires a positive rate of common randomness. This is coherent with the conjecture that, with enough common randomness, the strong coordination region is the same as the empirical coordination region for any network setting [7].

IV. ACHIEVABILITY

The achievability proofs have the following structure:

- 1) An i.i.d. random binning scheme and a random coding scheme are presented;
- 2) Strong coordination of $(M^n, C, F, W^n, X^n, Y^n, Z^n)$, by showing that the two schemes have the same statistics;
- 3) Proof of the reliable communication problem;

- 4) Optimization of the schemes to have coordination of the sequences of our interest only by reducing the rate of common randomness;
- 5) Summary of the rate conditions.

In particular, steps 2 and 4 use extensively the properties of the variational distance and the random binning techniques [8] here summarized.

Lemma 1 (Properties of the total variation distance):

- (i) $\mathbb{V}(P_A, \hat{P}_A) \leq \mathbb{V}(P_{AB}, \hat{P}_{AB})$, see [1, Lemma 16];
- (ii) $\mathbb{V}(P_A, \hat{P}_A) = \mathbb{V}(P_A P_{B|A}, \hat{P}_A P_{B|A})$, see [1, Lemma 17];
- (iii) if $\mathbb{V}(P_A P_{B|A}, P'_A P'_{B|A}) = \varepsilon$, then there exists $a \in \mathcal{A}$ such that $\mathbb{V}(P_{B|A=a}, P'_{B|A=a}) \leq 2\varepsilon$, see [8, Lemma 4].

Properties of random binning: Let $(A_{\llbracket 1, N \rrbracket}, B)$ be discrete memoryless correlated sources distributed according to $P_{A_{\llbracket 1, N \rrbracket}, B}$ on $\prod_{i=1}^N \mathcal{A}_i^n \times \mathcal{B}$. A distributed random binning $\varphi := (\varphi_1, \dots, \varphi_N)$ consists of a set of uniform random mappings $\varphi_i : \mathcal{A}_i^n \rightarrow \llbracket 1, 2^{nR_i} \rrbracket$, $i \in \llbracket 1, N \rrbracket$, and we denote $C_i := \varphi_i(A_i^n)$.

The first result ensures that the binnings are almost uniform and almost independent from B^n .

Theorem 2 ([8, Theorem 1]): If for every $\mathcal{S} \subseteq \llbracket 1, N \rrbracket$,

$$\sum_{s \in \mathcal{S}} R_s < H(A_{\mathcal{S}}|B),$$

then as n goes to infinity,

$$\mathbb{E}_{\varphi}[\mathbb{V}(P_{C_{\llbracket 1, N \rrbracket} B^n}, Q_{C_{\llbracket 1, N \rrbracket} B^n})] \rightarrow 0.$$

Then, we use the following to ensure the independence of one binning only.

Corollary 1 ([8, Corollary 1]): Let \mathcal{V} an arbitrary subset of $\llbracket 1, N \rrbracket$. If for every $\mathcal{S} \subseteq \llbracket 2, N \rrbracket \setminus \mathcal{V}$,

$$R_1 + \sum_{s \in \mathcal{S}} R_s < H(A_1 A_{\mathcal{S}} | B A_{\mathcal{V}}),$$

then as n goes to infinity,

$$\mathbb{E}_{\varphi}[\mathbb{V}(P_{C_{\llbracket 1, N \rrbracket} B^n}, Q_{C_1 P_{C_{\llbracket 2, N \rrbracket} B^n}})] \rightarrow 0.$$

Now, we state a lemma for a special case of the Slepian–Wolf Theorem for recovering only one source A_1^n from random bins C_1, \dots, C_N and side information B^n .

Lemma 2 ([8, Lemma 2]): If for every $\mathcal{S} \subseteq \llbracket 2, N \rrbracket$,

$$R_1 + \sum_{s \in \mathcal{S}} R_s > H(A_1 A_{\mathcal{S}} | B A_{\mathcal{S}^c}),$$

then as n goes to infinity,

$$\mathbb{E}_{\varphi}[\mathbb{V}(P_{A_{\llbracket 1, N \rrbracket} B^n \hat{A}_1^n}, P_{A_{\llbracket 1, N \rrbracket} B^n} \mathbb{1}\{\hat{A}_1^n = A_1^n\})] \rightarrow 0$$

where \hat{A}^n is the output of a Slepian–Wolf decoder.

A. Achievability Proof of Theorem 1

1) *I.i.d. random binning and random coding scheme:*

We present two distributions, a random binning scheme to synthesize the target i.i.d. distribution, and a random coding scheme to achieve the average performance.

a) *Random binning scheme:* We consider W^n generated i.i.d. according to $\bar{P}_{W^n} := \bar{P}_W^{\otimes n}$, and X^n generated i.i.d. according to $\bar{P}_{X^n|W^n} := \bar{P}_{X|W}^{\otimes n}$. Then, to all the sequences $\mathbf{w} \in \mathcal{W}^n$ we assign indices through the following uniform random binning:

- $\varphi_F : \mathcal{W}^n \rightarrow \llbracket 1, 2^{nR_F} \rrbracket$, $F = \varphi_F(W^n)$.

Moreover, to all the sequences $\mathbf{x} \in \mathcal{X}^n$ we assign indices through the following uniform random binnings:

- $\varphi_C : \mathcal{X}^n \rightarrow \llbracket 1, 2^{nR_C} \rrbracket$, where $C = \varphi_C(X^n)$ represents the codebook;
- $\varphi_M : \mathcal{X}^n \rightarrow \llbracket 1, 2^{nR_M} \rrbracket$, where $M^n = \varphi_M(X^n)$, represents the message.

The i.i.d. joint distribution induced by the binnings is:

$$\begin{aligned} P_{M^n C F W^n X^n Y^n Z^n}^{\text{RB}} & := \bar{P}_{W^n} P_F^{\varphi_F} \bar{P}_{X^n|W^n} P_C^{\varphi_C} P_{M^n|X^n}^{\varphi_M} \bar{P}_{Y^n Z^n|X^n} \\ & = P_{F M^n C}^{\text{RB}} P_{W^n|F}^{\text{RB}} P_{X^n|W^n M^n C}^{\text{RB}} \bar{P}_{Y^n Z^n|X^n}, \end{aligned} \quad (7)$$

where the pair of well-defined distributions $(P_{W^n|F}^{\text{RB}}, P_{X^n|W^n M^n C}^{\text{RB}})$ is used as an encoder in the random coding scheme.

b) *Random coding scheme:* We consider the joint distribution induced by the code:

$$\begin{aligned} P_{M^n C F W^n X^n Y^n Z^n}^{\text{RC}} & := Q_{M^n} Q_C Q_F P_{W^n|F}^{\text{RB}} P_{X^n|W^n M^n C}^{\text{RB}} \bar{P}_{Y^n Z^n|X^n}, \end{aligned} \quad (8)$$

and we choose the encoders $P_{W^n|F}^{\text{RB}}$, and $P_{X^n|W^n M^n C}^{\text{RB}}$ as defined in (7).

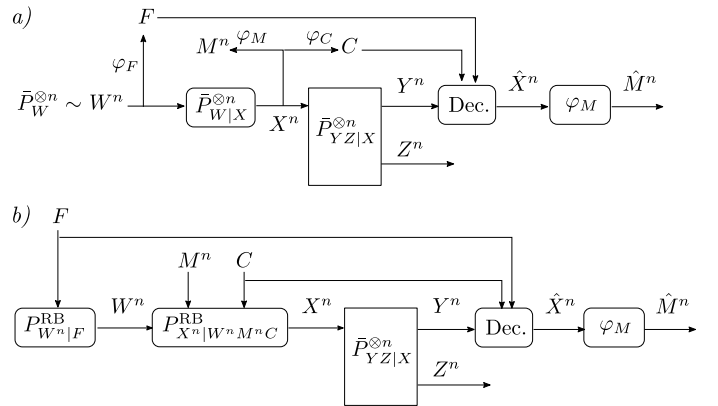

Figure 2. Proposed schemes and channel code construction: a) random binning scheme, b) random coding scheme.

2) *Approximating the target distribution – Strong coordination of $(M^n, C, F, W^n, X^n, Y^n, Z^n)$:* Observe that

$$\begin{aligned} & \mathbb{V}(P_{M^n C F W^n X^n Y^n Z^n}^{\text{RB}}, P_{M^n C F W^n X^n Y^n Z^n}^{\text{RC}}) \\ & \stackrel{(a)}{=} \mathbb{V}(P_{M^n C F W^n X^n}^{\text{RB}}, P_{M^n C F W^n X^n}^{\text{RC}}) \\ & \stackrel{(b)}{\leq} \mathbb{V}(P_{M^n C F}^{\text{RB}} P_{W^n|F}^{\text{RB}} P_{X^n|W^n M^n C}^{\text{RB}}, \\ & \quad Q_{M^n} Q_C Q_F P_{W^n|F}^{\text{RB}} P_{X^n|W^n M^n C}^{\text{RB}}) \end{aligned}$$

$$\begin{aligned}
& + \mathbb{V}(Q_{M^n} Q_C Q_F P_{W^n|F}^{\text{RB}} P_{X^n|W^n M^n C}^{\text{RB}}, P_{M^n C F W^n X^n}^{\text{RC}}) \\
\stackrel{(c)}{=} & \mathbb{V}(P_{M^n C F}^{\text{RB}} P_{W^n|F}^{\text{RB}} P_{X^n|W^n M^n C}^{\text{RB}}, \\
& Q_{M^n} Q_C Q_F P_{W^n|F}^{\text{RB}} P_{X^n|W^n M^n C}^{\text{RB}}) \\
\stackrel{(d)}{=} & \mathbb{V}(P_{M^n C F}^{\text{RB}}, Q_{M^n} Q_C Q_F) \tag{9}
\end{aligned}$$

where (a) comes from Lemma 1(ii) since $\bar{P}_{Y^n Z^n | X^n}$ appears in both (7) and (8), (b) is the triangle inequality and (c) comes from the definition of (8), and (d) from Lemma 1(ii).

Then, to prove that (9) vanishes, we need to impose rate conditions such that message M^n , codebook C and the extra randomness F are generated almost uniform and almost independent of each others. Thus, we apply Theorem 2 with $N = 2$, $A_{[1,2]} = ((X, X), W)$, $\varphi = ((\varphi_M, \varphi_C), \varphi_F)$, $C_{[1,2]} = ((M^n, C), F)$, and $B = \emptyset$. If

$$R_F < H(W), \tag{10a}$$

$$R_C + R_M < H(X), \tag{10b}$$

$$R_C + R_M + R_F < H(WX), \tag{10c}$$

there exists a fixed binning $\varphi^* = ((\varphi_M^*, \varphi_C^*), \varphi_F^*)$ such that $\mathbb{V}(P_{M^n C F}^{\text{RB}, \varphi^*}, Q_{M^n} Q_C Q_F)$ vanishes. Hence, we have

$$\mathbb{V}(P_{M^n C F W^n X^n Y^n Z^n}^{\text{RB}, \varphi^*}, P_{M^n C F W^n X^n Y^n Z^n}^{\text{RC}}) \rightarrow 0. \tag{11}$$

From now on, we consider the binning as fixed, and we write P^{RB} to simplify the notation.

3) *Reliable communication problem*: Now, we want the decoder to be able to reconstruct the message. Thus, we apply Lemma 2 to $N = 2$, $\mathcal{S} = \{2\}$ and $\mathcal{S} = \emptyset$, $A_1 = X$, $A_2 = W$, $\varphi = (\varphi_C, \varphi_F)$, $C_1 = C$, $C_2 = F$, and $B = Y$. If

$$R_C + R_F > H(XW|Y), \tag{12a}$$

$$R_C > H(X|WY), \tag{12b}$$

the decoder recovers an estimate of the input sequence \hat{X}^n from the binnings (C, F) and side information at the decoder Y^n via the Slepian–Wolf decoder with distribution $P_{\hat{X}^n | C F Y^n}^{\text{SW}}$.

Then $\hat{M}^n = \varphi_{M^n}(\hat{X}^n)$ is reconstructed reliably. The choice of the decoder defines the following complete joint random binning and random coding distributions:

$$P_{M^n C F W^n X^n Y^n Z^n}^{\text{RB}} P_{\hat{X}^n | C F Y^n}^{\text{SW}} \mathbb{1}\{\varphi_M(\hat{X}^n) = M^n\}, \tag{13a}$$

$$P_{M^n C F W^n X^n Y^n Z^n}^{\text{RC}} P_{\hat{X}^n | C F Y^n}^{\text{SW}} \mathbb{1}\{\varphi_M(\hat{X}^n) = M^n\}, \tag{13b}$$

where the first part of both schemes are defined in (7) and (8) respectively. Moreover, since the decoder is the same in both distributions, Lemma 1(ii) and (11) imply

$$\mathbb{V}(P_{M^n C F W^n X^n Y^n Z^n \hat{X}^n}^{\text{RB}}, P_{M^n C F W^n X^n Y^n Z^n \hat{X}^n}^{\text{RC}}) \rightarrow 0. \tag{14}$$

4) *Reducing the rate of common randomness – Remote strong coordination of Z^n* : With rate conditions (10b), (10c), (12a), and (12b) we ensure reliability and strong coordination of the whole sequence $(M^n, C, F, W^n, X^n, Y^n, Z^n)$. First, observe that Lemma 1(i) and (14) imply

$$\mathbb{V}(P_{M^n F Z^n}^{\text{RB}}, P_{M^n F Z^n}^{\text{RC}}) \rightarrow 0. \tag{15}$$

As in [8], we would like to reduce the amount of common randomness by having the two nodes agree on an instance $F = \mathbf{f}$. The first step, is to ensure that there exists a binning such that F is generated almost uniformly and independent of (M^n, Z^n) . To do this, we apply Corollary 1 with $N = 2$, $A_1 = W$, $A_2 = X$, $B = Z$, and $\mathcal{V} = \emptyset$. If

$$R_F + R_M < H(WX|Z), \tag{16a}$$

$$R_F < H(W|Z), \tag{16b}$$

we obtain

$$\mathbb{V}(P_{M^n F Z^n}^{\text{RB}}, Q_{M^n F Z^n}^{\text{RB}}) \rightarrow 0. \tag{17}$$

Combining the triangle inequality with (15) and (17), we have

$$\begin{aligned}
\mathbb{V}(Q_F P_{M^n Z^n}^{\text{RC}}, Q_F P_{M^n Z^n}^{\text{RB}}) & \leq \mathbb{V}(Q_F P_{M^n Z^n}^{\text{RC}}, P_{M^n F Z^n}^{\text{RB}}) \\
& + \mathbb{V}(P_{M^n F Z^n}^{\text{RB}}, Q_F P_{M^n Z^n}^{\text{RB}}) \rightarrow 0. \tag{18}
\end{aligned}$$

The second and final step is to use Lemma 1(iii), which ensures that, given (18), there exists an instance $\mathbf{f} \in \llbracket 1, 2^{nR_F} \rrbracket$ such that

$$\mathbb{V}(P_{M^n Z^n | F=\mathbf{f}}^{\text{RC}}, P_{M^n Z^n | F=\mathbf{f}}^{\text{RB}}) \rightarrow 0. \tag{19}$$

Remark 3 (Controlling the joint distribution–remotely coordinating Z^n): Observe that controlling the joint distribution $\bar{P}_{Z^n M^n}$ is equivalent to controlling the conditional distribution $\bar{P}_{Z^n | M^n}$, since M^n is generated uniformly by assumption. Thus, we are *remotely coordinating* Z^n .

Remark 4 (One binning for both conditions): We take $(\varphi_F^*, \varphi_M^*) = (\varphi'_F, \varphi'_M)$, which works for the conditions of both Section IV-A2 and Section IV-A5. For a thorough discussion on the existence of such binning, see [9, Remark 3.7].

Remark 5 (Stochasticity of encoder and decoder): Observe that, if instead of the stochastic function g_n , we consider the deterministic decoder \tilde{g}_n , that exploits external randomness U , we can always represent discrete stochastic decoders as discrete deterministic decoders with auxiliary randomness U . Each realization \mathbf{u} of U gives a deterministic decoder, and the average over all \mathbf{u} is equal to $p_e = \mathbb{P}\{M^n \neq \hat{M}^n\}$, since

$$p_e = \mathbb{P}\{M^n \neq \hat{M}^n\} = \mathbb{E}_U \left[\mathbb{P}\{M^n \neq \hat{M}^n | U\} \right] = \mathbb{E}_U [p_e(U)].$$

Hence, there exists at least one choice \mathbf{u}^* for which $p_e(\mathbf{u}^*) \leq p_e$. Since the choice of a deterministic decoder only concerns reliable communication and not approximating the target distribution, the decoder can be deterministic without loss of generality. Note that we cannot apply the same reasoning to the encoder: by assuming that the encoder is deterministic, we would restrict the choice of distributions $\bar{P}_{Z^n | M^n}$ that can be coordinated. Therefore, we will not achieve the whole coordination region.

5) *Rate conditions*: We retrieve the rate conditions of (2) by performing Fourier–Motzkin elimination with respect to R_F . More precisely, for the message rate we have

$$R_M \stackrel{(a)}{<} H(WX|Z), \quad (20a)$$

$$\begin{aligned} R_M &\stackrel{(b)}{<} H(X) + H(W|X) - (R_C + R_F) \\ &\stackrel{(c)}{<} H(X) + H(W|X) - H(XW|Y) \\ &= H(X) - H(X|Y) + H(W|X) - H(W|XY) \\ &= I(X; Y) + I(W; Y|X) \stackrel{(d)}{=} I(X; Y), \end{aligned} \quad (20b)$$

$$\begin{aligned} R_M &\stackrel{(e)}{<} H(X) - R_C \\ &\stackrel{(f)}{<} H(X) - H(X|WY) = I(X; WY), \end{aligned} \quad (20c)$$

where (a) follows from (16a), (b) is condition (10c), (c) comes from (12a) and (d) from the Markov Chain $W-X-Y$. Finally, (e) is condition (10b) and (f) follows from (12b). Then, by combining (20a), (20b), and (20c), we have

$$\begin{aligned} R_M &< \min\{H(WX|Z), I(X; Y), I(X; WY)\} \\ &= \min\{H(WX|Z), I(X; Y)\}. \end{aligned} \quad (21)$$

For the rate of common randomness, we have

$$\begin{aligned} R_C &\stackrel{(g)}{>} H(XW|Y) - R_F \\ &\stackrel{(h)}{>} H(XW|Y) - H(W|Z) \\ &= H(X|WY) + H(W|Y) - H(W|Z) \\ &= H(X|WY) + I(W; Z) - I(W; Y) \end{aligned} \quad (22a)$$

$$R_C \stackrel{(i)}{>} H(X|WY), \quad (22b)$$

where (g) is condition (12a), (h) follows from (16b), and (i) is condition (12b). Observe that (22a) and (22b) imply

$$R_C > \max\{0, I(W; Z) - I(W; Y)\}. \quad (23)$$

B. Achievability Proof of Proposition 1

The achievability follows from the proof of Theorem 1 by adding to rate constraints (10b), (10c), (12a), (12b), (16a) and (16b) the conditions to ensure that the message is independent of Z^n . Thus, we apply Theorem 2 with $N = 1$, $A_1 = X$, $B = Z$. If

$$R_M < H(X|Z), \quad (24)$$

the distance $\mathbb{V}(Q_{M^n} P_{Z^n}^{\text{RB}}, P_{M^n Z^n}^{\text{RB}})$ vanishes, and therefore

$$\mathbb{V}(Q_{M^n} P_{Z^n}^{\text{RB}}, P_{M^n Z^n}^{\text{RC}}) \rightarrow 0. \quad (25)$$

C. Achievability Proof of Proposition 2

The first three steps are the same as in Sections IV-A1, IV-A2, and IV-A3. In particular, the rate constraints (10b), (10c), (12a), and (12b) hold. Moreover, by Lemma 1(i), we have

$$\mathbb{V}(P_{FZ^n}^{\text{RC}}, P_{FZ^n}^{\text{RB}}) \rightarrow 0. \quad (26)$$

However, when reducing the rate of common randomness, we only want to control the marginal distribution \bar{P}_{Z^n} . Hence, we apply Theorem 2 with $N = 1$, $A_1 = W$, $B = Z$. If

$$R_F < H(W|Z), \quad (27)$$

the distance $\mathbb{V}(Q_F P_{Z^n}^{\text{RB}}, P_{FZ^n}^{\text{RB}})$ vanishes, and therefore

$$\mathbb{V}(Q_F P_{Z^n}^{\text{RB}}, P_{FZ^n}^{\text{RC}}) \rightarrow 0. \quad (28)$$

V. CONVERSE

The converse proofs use classical tools such as properties of mutual information and entropy, Fano's Inequality, and the Csiszár Sum Identity. Moreover, we will use the following technical result, well-suited for converses in coordination problems.

Lemma 3 ([10, Lemma 5]): Let $\bar{P}_A^{\otimes n}$ be i.i.d., and P_{A^n} be such that $\mathbb{V}(P_{A^n}, \bar{P}_A^{\otimes n})$ vanishes. Then, we have that

$$\sum_{t=1}^n I(A_t; A_{\sim t}) \leq n\varepsilon.$$

A. Converse Proof of Theorem 1

Consider a code (f_n, g_n) that induces a distribution $P_{Z^n|M^n}$ on the actions that is ε -close in total variation distance to the i.i.d. distribution $\bar{P}_{Z|M}^{\otimes n}$ and such that $\mathbb{P}\{M^n \neq \hat{M}^n\} \leq \varepsilon$. Furthermore, let the random variable T be uniformly distributed over the set $\llbracket 1, n \rrbracket$ and independent of the variables (X^n, Y^n, Z^n, C, M^n) .

1) *Rate of common randomness*: We have

$$\begin{aligned} nR_C &= H(C) \geq I(C; M^n Z^n) \\ &= \sum_{t=1}^n I(C; M_t Z_t | Z^{t-1} M^{t-1}) \geq \sum_{t=1}^n I(C; Z_t | Z^{t-1} M^{t-1}) \\ &\geq \sum_{t=1}^n [I(C; Z_t | Z^{t-1} M^{t-1}) - I(C; Y_t | Y_{t+1}^n M^{t-1})] \\ &= \sum_{t=1}^n [I(CY_{t+1}^n; Z_t | Z^{t-1} M^{t-1}) \\ &\quad - I(Y_{t+1}^n; Z_t | Z^{t-1} M^{t-1} C)] \\ &\quad - \sum_{t=1}^n [I(CZ^{t-1}; Y_t | Y_{t+1}^n M^{t-1}) \\ &\quad - I(Z^{t-1}; Y_t | Y_{t+1}^n M^{t-1} C)] \\ &\stackrel{(a)}{\geq} \sum_{t=1}^n [I(CY_{t+1}^n; Z_t | Z^{t-1} M^{t-1}) \\ &\quad - I(CZ^{t-1}; Y_t | Y_{t+1}^n M^{t-1})] \\ &\stackrel{(b)}{\geq} \sum_{t=1}^n [I(CZ^{t-1} Y_{t+1}^n M^{t-1}; Z_t) \\ &\quad - I(CZ^{t-1}; Y_t | Y_{t+1}^n M^{t-1})] - n\varepsilon \\ &\geq \sum_{t=1}^n [I(CZ^{t-1} Y_{t+1}^n M^{t-1}; Z_t) \\ &\quad - I(CZ^{t-1} Y_{t+1}^n M^{t-1}; Y_t)] - n\varepsilon \end{aligned}$$

$$\begin{aligned}
&\stackrel{(c)}{=} \sum_{t=1}^n [I(W_t; Z_t) - I(W_t; Y_t)] - n\varepsilon \\
&= nI(W_T; Z_T|T) - nI(W_T; Y_T|T) - n\varepsilon \\
&\stackrel{(d)}{\geq} nI(W_T T; Z_T) - nI(W_T T; Y_T) - 2n\varepsilon \\
&\stackrel{(e)}{=} nI(W; Z) - nI(W; Y) - 2n\varepsilon \tag{29}
\end{aligned}$$

where (a) comes from the Csiszár Sum Identity. To prove (b), observe that

$$\begin{aligned}
&I(CY_{t+1}^n Z^{t-1} M^{t-1}; Z_t) - I(CY_{t+1}^n; Z_t | Z^{t-1} M^{t-1}) \\
&= I(Z_t; Z^{t-1} M^{t-1}) \leq I(M_t Z_t; Z_{\sim t} M_{\sim t}) \leq \varepsilon \tag{30}
\end{aligned}$$

from Lemma 3 and assumption (1a). Then, (c) follows from the identification $W_t = (C, Z^{t-1}, Y_{t+1}^n, M^{t-1})$, (d) from the fact that $I(Z_T; T) \leq \varepsilon$ since Z^n is almost i.i.d. by assumption (1a) and $I(W_T; Y_T|T) \leq I(W_T T; Y_T)$. Finally, (e) comes from the identification $W = (W_T, T)$.

2) *Rate of the message:*

a) $R_M < \max_{P_X} I(X; Y)$: It follows from Fano's Inequality, since the probability of error tends to zero. For more details, see [6].

b) $R_M < \max_{P_X} H(XW|Z)$: We have

$$\begin{aligned}
nR_M &= H(M^n) = \sum_{t=1}^n H(M_t | M^{t-1}) \stackrel{(a)}{=} \sum_{t=1}^n H(M_t) \\
&\stackrel{(b)}{\leq} \sum_{t=1}^n H(M^{t-1}) \stackrel{(c)}{\leq} \sum_{t=1}^n H(M^{t-1} Z^{t-1} | Z_t) + n\varepsilon \\
&\leq \sum_{t=1}^n H(M^{t-1} Z^{t-1} Y_{t+1}^n C X_t | Z_t) + n\varepsilon \\
&\stackrel{(d)}{=} \sum_{t=1}^n H(W_t X_t | Z_t) + n\varepsilon = nH(W_T X_T | Z_T T) + n\varepsilon \\
&\leq nH(W_T X_T T | Z_T) + n\varepsilon \stackrel{(e)}{=} nH(WX|Z) + n\varepsilon \tag{31}
\end{aligned}$$

where (a) comes from the fact that M^n is i.i.d., and (b) holds from the same reason if $n > 2$. Then, (c) follows from

$$\begin{aligned}
&H(M^{t-1}) - H(M^{t-1} Z^{t-1} | Z_t) \\
&\leq H(M^{t-1} Z^{t-1}) - H(M^{t-1} Z^{t-1} | Z_t) \\
&= I(Z_t; Z^{t-1} M^{t-1}) \leq I(M_t Z_t; Z_{\sim t} M_{\sim t}) \leq \varepsilon \tag{32}
\end{aligned}$$

by Lemma 3 and assumption (1a). Finally, in steps (d) and (e) we identify $W_t = (C, Z^{t-1}, Y_{t+1}^n, M^{t-1})$, $W = (W_T, T)$. Observe that W_t defined in this way verifies the Markov Chain $W_t - X_t - (Y_t, Z_t)$.

c) *Cardinality bound:* The cardinality bound on \mathcal{W} is a consequence of the Fenchel–Eggleston–Carathéodory Theorem [6, Appendix C]. The proof is omitted.

B. Converse Proof of Proposition 1

1) *Rate of common randomness:* See Section V-A1.

2) *Rate of the message:*

a) $R_M < \max_{P_X} I(X; Y)$: See Section V-A2a

b) $R_M < \max_{P_X} H(X|Z)$: We have

$$\begin{aligned}
nR_M &= H(M^n) \\
&\stackrel{(a)}{=} H(M^n | Z^n) + n\varepsilon \\
&\leq H(M^n X^n | Z^n) + n\varepsilon \\
&= H(X^n | Z^n) + H(M^n | X^n Z^n) + n\varepsilon \\
&\leq H(X^n | Z^n) + H(M^n | X^n) + n\varepsilon \\
&\stackrel{(b)}{\leq} H(X^n | Z^n) + 3n\varepsilon \\
&= \sum_{t=1}^n H(X_t | X^{t-1} Z^n) + 3n\varepsilon \\
&\leq \sum_{t=1}^n H(X_t | Z_t) + 3n\varepsilon \\
&= nH(X_T | Z_T, T) + 3n\varepsilon \\
&\leq nH(X|Z) + 3n\varepsilon \tag{33}
\end{aligned}$$

where (a) comes from (3). To prove (b), observe that

$$\begin{aligned}
&H(M^n | X^n) \leq H(M^n \hat{M}^n | X^n) \\
&= H(\hat{M}^n | X^n) + H(M^n | X^n \hat{M}^n) \\
&\stackrel{(c)}{\leq} H(\hat{M}^n | X^n) + n\varepsilon \stackrel{(d)}{\leq} H(\hat{M}^n | M^n C) + n\varepsilon \\
&\leq H(\hat{M}^n | M^n) + n\varepsilon \stackrel{(e)}{\leq} 2n\varepsilon \tag{34}
\end{aligned}$$

where (c) comes from the fact that $H(M^n | X^n \hat{M}^n) \leq H(M^n | \hat{M}^n) \leq n\varepsilon$ by Fano's Inequality since the probability of M^n being different from \hat{M}^n tends to zero. Then, because of the Markov chain $M^n C - X^n - Y^n - \hat{M}^n$, (d) follows from the data processing inequality. Finally, (e) comes from Fano's Inequality.

C. Converse Proof of Proposition 2

1) *Rate of common randomness:* The proof is similar to the one in Section V-A1, but since the assumptions are slightly different, we need a different identification for the auxiliary random variable W . More precisely, we have

$$\begin{aligned}
nR_C &= H(C) \geq I(C; Z^n) \geq I(C; Z^n) - I(C; Y^n) \\
&= \sum_{t=1}^n I(C; Z_t | Z^{t-1}) - \sum_{t=1}^n I(C; Y_t | Y_{t+1}^n) \\
&\stackrel{(a)}{=} \sum_{t=1}^n I(CY_{t+1}^n; Z_t | Z^{t-1}) - \sum_{t=1}^n I(CZ^{t-1}; Y_t | Y_{t+1}^n) \\
&\stackrel{(b)}{\geq} \sum_{t=1}^n I(CZ^{t-1} Y_{t+1}^n; Z_t) - \sum_{t=1}^n I(CZ^{t-1}; Y_t | Y_{t+1}^n) - n\varepsilon \\
&\geq \sum_{t=1}^n I(CZ^{t-1} Y_{t+1}^n; Z_t) - \sum_{t=1}^n I(CZ^{t-1} Y_{t+1}^n; Y_t) - n\varepsilon \\
&\stackrel{(c)}{=} \sum_{t=1}^n I(W_t; Z_t) - \sum_{t=1}^n I(W_t; Y_t) - n\varepsilon \\
&= nI(W_T; Z_T | T) - nI(W_T; Y_T | T) - n\varepsilon \\
&\stackrel{(d)}{\geq} nI(W_T T; Z_T) - nI(W_T T; Y_T) - 2n\varepsilon \\
&\stackrel{(e)}{=} nI(W; Z) - nI(W; Y) - 2n\varepsilon \tag{35}
\end{aligned}$$

where (a) comes from the Csiszár Sum Identity. To prove (b), observe that

$$\begin{aligned} I(CY_{t+1}^n Z^{t-1}; Z_t) - I(CY_{t+1}^n; Z_t | Z^{t-1}) \\ = I(Z_t; Z^{t-1}) \leq I(M_t Z_t; Z_{\sim t} M_{\sim t}) \leq \varepsilon \end{aligned} \quad (36)$$

from Lemma 3 and assumption (5a). Then, (c) follows from the identification $W_t = (C, Z^{t-1}, Y_{t+1}^n)$, (d) from the fact that $I(Z_T; T) \leq \varepsilon$ since Z^n is almost i.i.d. by assumption (1a) and $I(W_T; Y_T | T) \leq I(W_T T; Y_T)$. Finally, (e) comes from the identification $W = (W_T, T)$.

2) *Rate of the message*: See Section V-A2a.

REFERENCES

- [1] P. Cuff, “Communication in networks for coordinating behavior,” Ph.D. dissertation, Stanford University, 2009.
- [2] S. Satpathy and P. Cuff, “Secure coordination with a two-sided helper,” in *2014 IEEE Int. Symp. Inf. Theory (ISIT)*, Jun. 2014, pp. 406–410.
- [3] —, “Secure cascade channel synthesis,” *IEEE Trans. Inf. Theory*, vol. 62, no. 11, pp. 6081–6094, Nov. 2016.
- [4] M. R. Bloch and J. Barros, *Physical-layer security: from information theory to security engineering*. Cambridge University Press, 2011.
- [5] R. Blasco-Serrano, R. Thobaben, and M. Skoglund, “Communication and interference coordination,” in *2014 Information Theory and Applications Workshop (ITA)*. IEEE, 2014, pp. 1–8.
- [6] A. El Gamal and Y. H. Kim, *Network information theory*. Cambridge University Press, 2011.
- [7] P. W. Cuff, H. H. Permuter, and T. M. Cover, “Coordination Capacity,” *IEEE Trans. Inf. Theory*, vol. 56, no. 9, pp. 4181–4206, 2010.
- [8] M. H. Yassaee, M. R. Aref, and A. Gohari, “Achievability Proof via Output Statistics of Random Binning,” *IEEE Trans. Inf. Theory*, vol. 60, no. 11, pp. 6760–6786, Nov. 2014.
- [9] G. Cervia, “Coordination of autonomous devices over noisy channels: capacity results and coding techniques,” Ph.D. dissertation, Université Paris Seine, 2018. [Online]. Available: <https://www.theses.fr/2018CERG0960>
- [10] G. Cervia, L. Luzzi, M. Le Treust, and M. R. Bloch, “Strong coordination of signals and actions over noisy channels,” in *2017 IEEE Int. Symp. Inf. Theory (ISIT)*, Jun. 2017, pp. 2835–2839.