PARALLEL ONE-STEP CONTROL OF PARAMETRISED BOOLEAN NETWORKS

A PREPRINT

Luboš Brim
Masaryk University
brim@fi.muni.cz

Samuel Pastva
Masaryk University
xpastva@fi.muni.cz

David Šafránek
Masaryk University
safranek@fi.muni.cz

Eva Šmijáková
Masaryk University
xsmijak1@fi.muni.cz

September 2, 2020

ABSTRACT

Boolean network (BN) is a simple model widely used to study complex dynamic behaviour of biological systems. Nonetheless, it might be difficult to gather enough data to precisely capture the behavior of a biological system into a set of Boolean functions. These issues can be dealt with to some extent using parametrised Boolean networks (ParBNs), as it allows to leave some update functions unspecified. In this paper, we attack the control problem for ParBNs with asynchronous semantics. While there is an extensive work on controlling BNs without parameters, the problem of control for ParBNs has not been in fact addressed yet. The goal of control is to ensure the stabilisation of a system in a given state using as few interventions as possible. There are many ways to control BN dynamics. Here, we consider the one-step approach in which the system is instantaneously perturbed out of its actual state. A naïve approach to handle control of ParBNs is using parameter scan and solve the control problem for each parameter valuation separately using known techniques for non-parametrised BNs. This approach is however highly inefficient as the parameter space of ParBNs grows doubly-exponentially in the worst case. In this paper, we propose a novel semi-symbolic algorithm for the one-step control problem of ParBNs, that builds on a symbolic data structures to avoid scanning individual parameters. We evaluate the performance of our approach on real biological models.

Keywords Boolean networks · parameters · control · reprogramming · attractors · perturbations

1 Introduction

Cell reprogramming is currently one of the most critical challenges in computational biology. The goal of cell reprogramming is to *control* a cell's phenotype. This ability opens many opportunities, mainly in regenerative medicine. In order to reach the desired phenotype, the correct transcription factors must be identified. That is close to impossible to be done only using *in vitro* biological experiments due to the very high number of possibilities how the cell might be interfered with. This is where *in silico* analysis and computational models of cell dynamics come into play. Formal methods and their integration provide a promising technology that allows fully automatic identification of control strategies by using computational models.

A cell can be viewed as a set of genes and their mutual regulators. The compact abstraction of these relationships can be modelled using *Boolean networks* (BNs). BNs are becoming very popular means for *in silico* experiments, as they are both simple and expressive [1]. Moreover, BNs have applications not only in molecular biology, but also in many other areas including circuit theory and computer science. BNs are composed of two essential parts. The first part is a finite set of Boolean *variables* representing genes or other biochemical substances. The second part is a set of

Boolean *update functions* which specify the way variables dynamically change their value based on influences from other variables. Typically, influences among variables are visualised in the form of a so-called regulatory network displaying the structure of a BN (an example is shown in Fig. 2a).

In BN models, time is considered to be *discrete*. At each time step, some variables are selected for an update. The scheduling of updates has a strong influence on the reachable configurations of the variables. There are two dominant updating paradigms. The *synchronous* paradigm updates all variables simultaneously, and thus generates deterministic dynamics. In contrast, the (fully) *asynchronous* paradigm updates a single non-deterministically selected variable at each time step. In this work, we consider the asynchronous update schedule as it often captures the behaviour of biological systems more realistically compared to its synchronous counter-part [2].

At any particular time moment, the tuple of all variables' values in the BN is called a *state* of the network. The *state-transition graph* (STG) has as its *nodes* the states, and each directed edge represents a possible transition from one state to another one in a single update. The size of the STG grows exponentially with the number of variables, which causes the state-space explosion problem. Since the BN is a finite-state system, the state of the system will in a long-run evolve into a single state (steady-state) or a set of recurring states (a complex attractor). These steady states or recurring states are collectively called *attractors* and correspond with the *terminal strongly connected components* (TSCC) in the STG.

A significant shortcoming of BNs when used for modelling a real phenomena resides in the necessity to fully specify the update functions. In practice, it is often complicated to exactly identify Boolean functions from biological data. However, there is typically a good evidence of the fact that a variable regulates another one. *Parametrised Boolean networks* (ParBN) [3, 4] address the possibility to specify BNs without the precise knowledge of some update functions; the unknown part is represented in terms of *logical parameters*. In ParBNs, only regulators of a variable need to be specified. This allows to capture multiple variants of the possible actual behaviour of variables without conducting many more expensive experimental observations. A disadvantage of ParBNs is that their analysis is significantly more difficult compared to the non-parametrised case as the edges in the STG change according to the chosen *parametrisations*, i.e., a particular setting of logical parameters in the specification of update functions.

The goal of the *Boolean network control* is to influence the behaviour of the network so that it stabilises in a particular attractor. A typical way to change the behaviour is to perturb the values of some variables. In this paper, we consider *one-step state perturbations* in which we apply all the perturbations of variables simultaneously and only once. After the perturbation, the system is left to behave normally. Solutions of the Boolean network control problem for a model of a cell *in silico* provide the basis for experimental designs allowing to reprogram the cell *in vitro*. Since practical realisation of particular perturbations requires non-trivial effort, the number of perturbations typically needs to be minimised. To that end, the control problem is usually enriched with some optimisation criteria.

In this paper, we focus on the *source-target* variant of the ParBN control problem where both the source and the target states are given in advance. To the best of our knowledge, we provide the first efficient solution to the one-step target control of ParBNs. It is worth noting that the parameters bring many new challenges to the control problem. First, the attractors might significantly change with the change in the parametrisation of the network. Second, the minimal state perturbation does not necessarily work for all parametrisations, and therefore, the notion of the optimal control strategy needs to be adapted to such a situation. Third, the parameter-space explosion (in addition to the state-space explosion) makes the problem computationally demanding. The parameter space is in the worst case, doubly-exponential [5]. Each ParBN parametrisation generates a unique BN model with a unique STG. That is why using algorithms developed for asynchronous non-parametrised BNs and computing the control set for each parametrisation distinctly (parameter scan) is not feasible, and a new approach needs to be developed.

Contribution

We propose an efficient alternative to the naïve parameter scan approach to compute the one-step target control of ParBNs. Technically, our approach relies on the integration of several formal methods. In particular, we employ a representation of ParBNs based on a symbolic edge-coloured graph using BDDs [4, 6]. For this representation, we extend a well-established algorithm for asynchronous BNs control employing one-step perturbations [7]. The technique is based on the identification of attractor's strong basin. Our novel algorithm is able to compute the strong basins of all ParBN parametrisations simultaneously instead of computing them one by one (individually for every parametrisation). We show that for highly parametrised models, our approach is significantly more efficient than the naïve approach.

Related Work

Typically, two elementary types of control problems are distinguished: (i) achieving a single desired target attractor irrespective of the current state (target control) [8], (ii) achieving control between every pair of attractors (full control) [9]. Here, we focus on the target control.

The target control problem has been studied in non-parametrised BNs with both the synchronous and asynchronous update. In synchronous case, the method [8] identifies the control kernel, a minimal set of nodes, inferred from the explicit STG of the BN. In [10] a network graph aggregation approach is employed at the level of the regulatory network avoiding construction of the full STG. In [11], the regulatory network is divided to partially-dependent parts identified as strongly connected components. In the case of asynchronous BNs, the approach in [12] computes a set of relevant BN variables based on the identification of particular motifs in the regulatory network.

Traditional approaches mentioned above assume the control to be implemented by involving a permanent perturbation applied continuously for an extended period of time. However, this is not possible to be efficiently achieved in practise [13]. To that end, the concept of one-step perturbation has been introduced in [7] in the context of asynchronous BNs (the perturbation is applied in the initial state, and after that the system evolves according to its original dynamics). The algorithms in [7] address both target and full control, and they solve the existential problem as well as the optimal problem (identifying the minimal set of perturbations). The method is based on an efficient identification of a strong basin. In this paper, we employ a similar idea for the target control in the novel context of ParBNs.

It is also worth noting that in [14, 15] the authors work with the concept of temporary perturbations filling the gap between one-step and permanent perturbations. Moreover, complex control strategies considering temporal sequences of perturbations are studied in [16–19]. All those results are developed for non-parametrised BNs only.

The approaches mentioned in this subsection cannot be directly lifted to work with ParBNs (the naïve solution considering iteration of existing methods is infeasible due to the combinatorial explosion of the parameter space). As already stated above, we propose the first efficient solution to the one-step target control of ParBNs.

2 Preliminaries

In this section, we introduce Boolean networks (BNs) and define related terms regarding long-term behaviour of BNs. Then we expand the notion of BNs by adding parameters, allowing for unspecified or unknown behaviour in the network.

2.1 Boolean Networks

Boolean networks are a simple model widely used to study complex dynamic behaviour of biological systems. That is why we define Boolean networks in a way that closely relates to *regulatory networks*, which represent biological processes using directed dependency graphs of biochemical entities:

Definition 2.1 (Boolean network). A *Boolean network* is a tuple $\mathcal{B} = (\mathcal{V}, R, \mathcal{F})$ such that:

- $\mathcal{V} = \{A, B, \dots\}$ is a finite set of Boolean *state variables*.
- $R \subseteq \mathcal{V} \times \mathcal{V}$ is a set of *regulations*. For $A \in \mathcal{V}$, we say that $\mathcal{T}(A) = \{B \in \mathcal{V} \mid (B, A) \in R\}$ is the *context* of A , i.e. the subset of \mathcal{V} regulating A .
- $\mathcal{F} = \{F_A \mid A \in \mathcal{V}\}$ is a family of *logical update functions*. The signature of each F_A is given by the context of A as $F_A : \{0, 1\}^{\mathcal{T}(A)} \rightarrow \{0, 1\}$.

2.1.1 State space

A *state* s of a BN \mathcal{B} is a valuation of its Boolean variables, i.e. $s : \mathcal{V} \rightarrow \{0, 1\}$. The set of all possible states is $\Pi(\mathcal{B}) = \{0, 1\}^{\mathcal{V}}$ and is called the *state space* of \mathcal{B} . Given a state s , $s[A \mapsto b]$ denotes a copy s where the value of A is set to $b \in \{0, 1\}$. Finally, for a state s and an update function F_A , we use the abbreviated notation $F_A(s)$ to denote F_A applied to s restricted to the context of A .

2.1.2 Hamming difference and distance

The states of BN are Boolean (binary) configurations of variables. That is why we can conduct standard Hamming operations on them. Given two states s, s' , their *Hamming difference* $\text{hdif}(s, s')$ is the set of all variables in which

the two states differ: $\text{hdif}(s, s') = \{A \in \mathcal{V} \mid s(A) \neq s'(A)\}$. The *Hamming distance* is then the cardinality of this set, $\text{hdis}(s, s') = |\text{hdif}(s, s')|$.

2.1.3 Regulatory network

With every BN \mathcal{B} it is possible to associate a directed graph (\mathcal{V}, R) called a *regulatory network* or a *dependency graph* of \mathcal{B} . This graph captures influences among the variables of \mathcal{B} . When visualising a BN, its regulatory network is usually displayed as a directed graph (with update functions specified separately). For a BN \mathcal{B} , one also often considers certain general properties of its regulations, which can then be depicted in the regulatory network.

2.1.4 Regulation types

We say that a regulation $(A, B) \in R$ is *observable* if there exists a state such that changing the value of A also changes the value of F_B , formally:

$$\exists s \in \Pi(\mathcal{B}) : F_B(s[A \mapsto 0]) \neq F_B(s[A \mapsto 1])$$

Intuitively, this means that the presence of one biochemical entity has an observable influence on another entity. When a regulation is not marked observable, it can have an influence on the regulated entity, but we do not enforce it. Such regulations are drawn with a question mark.

In addition to observability, we also consider two possible *monotonicity* properties of a regulation: *activation* and *inhibition*. Regulation is activating if by increasing A it is not possible to decrease F_B . For example, if A and C activate B , the possible functions F_B are $A \vee C$ or $A \wedge C$. On the contrary, regulation is inhibiting, if by increasing A one can not increase the value of F_B . For example, if A and C inhibit B , the possible functions F_B are $\neg A \vee \neg C$ or $\neg A \wedge \neg C$. There can be regulations which are neither activating nor inhibiting. However, most regulations in this paper are either inhibiting or activating as this is typical for biological models. Graphically, activating regulation is depicted as a regular green arrow while inhibiting regulation is drawn as a flat red arrow (see Fig. 2a).

2.1.5 Dynamics

The complete dynamical behaviour of a boolean network \mathcal{B} is captured by the directed *state-transition graph* (STG) $\mathcal{G} = (S, T)$, where $S = \Pi(\mathcal{B})$ and $T \subseteq S \times S$. The definition of the *transition relation* T depends on the *updating scheme* that defines the way variables update their states along time. In this paper, we consider *asynchronous* updating. At a discrete time step, the system non-deterministically applies some $F_A \in \mathcal{F}$ to a state s . We then obtain a *transition relation* \rightarrow which is defined as follows:

$$(s, t) \in \rightarrow \text{ if and only if } s \neq t \wedge \exists F_A \in \mathcal{F} : s[A \mapsto F_A(s)] = t$$

Note that for every $(s, t) \in \rightarrow$ the Hamming distance $\text{hdis}(s, t) = 1$ as during one step only one variable can change its value. For $(s, t) \in \rightarrow$, we simply write $s \rightarrow t$. We use \rightarrow^* to denote a reflexive and transitive closure of \rightarrow , also writing $s \rightarrow^* t$ when $(s, t) \in \rightarrow^*$. Also note that the transition relation is *non-deterministic*. We denote $\text{Async}(\mathcal{B})$ the state-transition graph of \mathcal{B} under asynchronous updating scheme.

When studying the long-term behaviour of a BN, we typically only consider *fair* infinite paths in the state-transition graph. In a fair path, if a transition is enabled infinitely often, it has to be taken infinitely often. Therefore, the system cannot infinitely delay the available transitions, and it is not possible to cycle forever in a non-terminal strongly connected component.

2.1.6 Attractors

The long-term behaviour of BNs is captured by the notion of *attractors*. In biological models, we observe a phenotype in which the system eventually stabilises, whereas, in BN computational model, we observe attractors which are understood as terminal strongly connected components of the STG. In the following, we use these two terms interchangeably.

Definition 2.2 (Attractor). Let $\mathcal{B} = (\mathcal{V}, R, \mathcal{F})$ be a BN. An *attractor* of \mathcal{B} is a terminal strongly connected component (TSCC) in $\text{Async}(\mathcal{B})$, i.e. a maximal subset $A \subseteq \Pi(\mathcal{B})$ such that for all $s, t \in A$, $s \rightarrow^* t$, and for all $s \in A$ and $t \in \Pi(\mathcal{B})$, $s \rightarrow t$ implies $t \in A$.

We denote a set of all attractors of \mathcal{B} as $\mathbb{A}(\mathcal{B})$ or simply as \mathbb{A} if \mathcal{B} is clear from the context. For a fixed state s , we define $\text{Att}(s)$ to be an attractor $A \in \mathbb{A}$ such that $s \in A$, or an empty set when s does not belong to any attractor. Furthermore, for an attractor $A \in \mathbb{A}(\mathcal{B})$ we also define notion of its weak and strong basins.

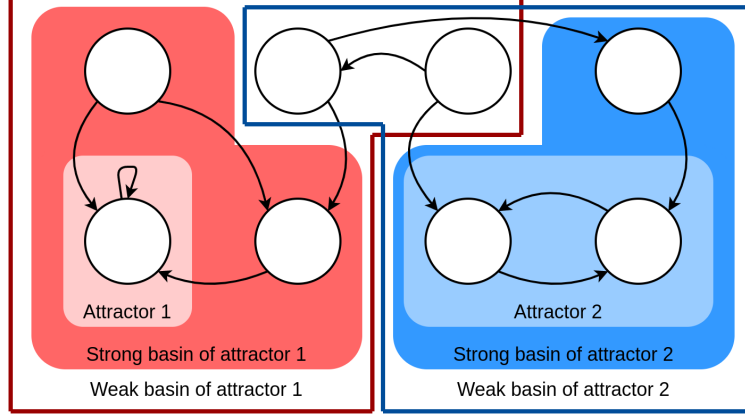

Figure 1: Attractors, weak basins and strong basins in a BN. The BN contains two attractors: single-state attractor 1 (light-red area) and cyclic two-states attractor 2 (light-blue area). Both these attractors have strong basins of size 3 (solid red area for attractor 1, blue are for attractor 2 resp.). Note that states of attractors are also parts of their basins. Moreover, the strong basins never have any intersections as given by definition. Finally, the red-lined and blue-lined areas contain weak basin states of attractor 1 and attractor 2. The strong basin is always a subset of a weak basin. The weak basins are over-lapping.

Definition 2.3 (Weak and strong basin). Let $\mathcal{B} = (\mathcal{V}, R, \mathcal{F})$ be a BN and A its attractor. A *weak basin* of A is the set of states from which it is possible to reach A :

$$\text{WB}(\mathcal{B}, A) = \{s \in \Pi(\mathcal{B}) \mid s \rightarrow^* t \text{ for some } t \in A\}$$

A *strong basin* is a set of states from which it is *not* possible to reach *any other* attractor than attractor A :

$$\text{SB}(\mathcal{B}, A) = \text{WB}(\mathcal{B}, A) \setminus \bigcup_{A' \in \mathcal{A}[A' \neq A]} \text{WB}(\mathcal{B}, A')$$

Notice that due to the fairness property, once a strong basin of an attractor A is reached, the system eventually stabilises in the given attractor. For better illustration, Figure 1 depicts weak and strong basins of some BN.

2.2 Parametrised Boolean Networks

Given a complex real-life system it might be very challenging to precisely determine all the update functions \mathcal{F} of a Boolean network. *Parametrised Boolean networks* [3,4] provide a framework to deal with the lack of precise knowledge about the updating mechanism in a system. This extension assumes a set of logical parameters which determine the behaviour of update functions. Therefore, parametrised logical update functions either return a Boolean value (they behave normally) or a logical parameter representing the uncertainty of the consequent behaviour:

Definition 2.4 (Parametrised Boolean network). We define a *parametrised Boolean network (ParBN)* to be a tuple $\hat{\mathcal{B}} = (\mathcal{V}, \mathcal{P}, R, P, \mathfrak{F})$. Here, \mathcal{V} and R are the same as in Definition 2.1 and

- $\mathcal{P} = \{P, Q, \dots\}$ is a finite set of Boolean *logical parameters*;
- $P \subseteq \{0, 1\}^{\mathcal{P}}$ is a subset of valid *parametrisations*;
- $\mathfrak{F} = \{\hat{F}_A \mid A \in \mathcal{V}\}$ is a family of *parametrised logical update functions*. The signature of each \hat{F}_A is given as $\hat{F}_A : \{0, 1\}^{\mathcal{T}(A)} \rightarrow (\{0, 1\} \cup \mathcal{P})$.

For $p \in P$, we write $p(P)$ to denote the value of P in p and we also use the same notation $p[P \mapsto k]$ for substitution as we used for states. The notion of the state space of a ParBN is identical to that of a BN. By fixing $p \in P$, we obtain $\hat{\mathcal{B}}_p = (\mathcal{V}, R, \mathfrak{F}(p))$ (a standard BN), \mathcal{A}_p (the set of attractors of $\hat{\mathcal{B}}_p$), and $\text{Att}_p(s)$ (the attractor of state s in the parametrisation p).

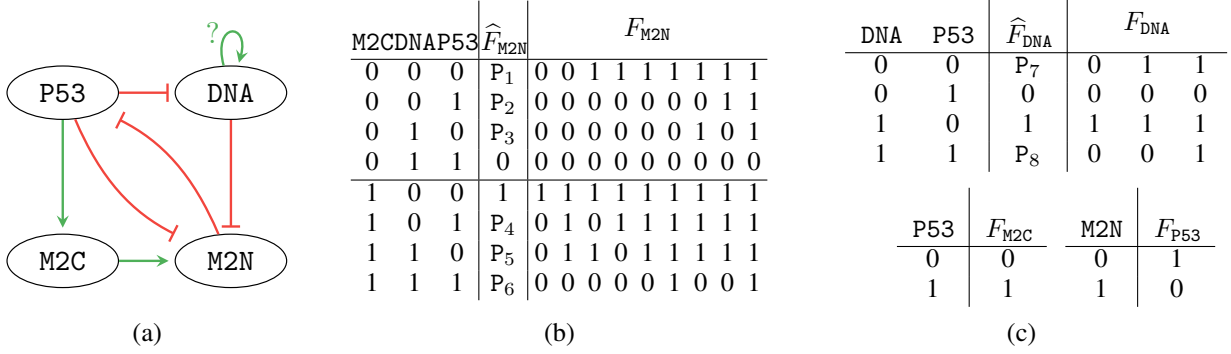

Figure 2: (a) A regulatory network of a simplified ParBN describing the DNA damage mechanism adapted from [20]. Every regulation is either activating (green) or inhibiting (red) and observable, except for (DNA, DNA), which is not necessarily observable. (b) All possible valid update functions F_{M2N} satisfying the static constraints (monotonicity, observability). (c) Valid update functions F_{DNA} , F_{M2C} and F_{P53} satisfying the static constraints. Here, P_i denote the parameters (\mathcal{P}) of the ParBN.

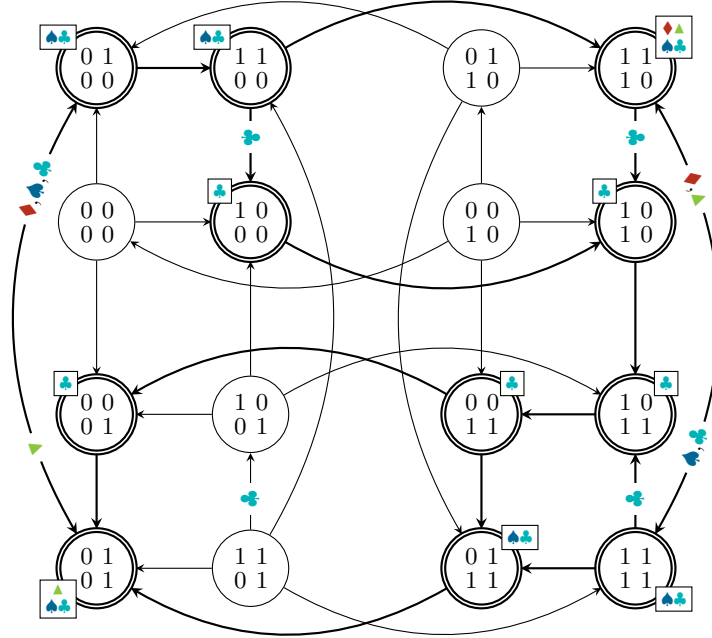

Figure 3: The asynchronous semantics of the ParBN given in Fig. 2a, restricted to $\mathcal{P} = \{\diamond, \triangle, \spadesuit, \clubsuit\}$. Here, $\diamond = \{P_{2,3,6} : 0, P_{1,4,5,7,8} : 1\}$, $\triangle = \diamond[P_3 \mapsto 1]$, $\spadesuit = \diamond[P_6 \mapsto 1]$, and $\clubsuit = \spadesuit[P_8 \mapsto 0]$. The unlabelled edges are enabled for all parametrisations. The highlighted vertices represent attractors for indicated parametrisations.

2.2.1 Dynamics

The asynchronous semantics of a ParBN $\widehat{\mathcal{B}}$ is represented using an *edge-labelled state-transition graph* $Async(\widehat{\mathcal{B}})$, where each transition $s \rightarrow t$ is labelled with a subset of parametrisations $P(s, t) \subseteq \mathcal{P}$ for which it is enabled. That is, $p \in P(s, t)$ if and only if $s \rightarrow t$ in $Async(\widehat{\mathcal{B}}_p)$. For a fixed s , we denote $successors(s)$ the set of all successors of s (states with Hamming distance one). In Fig. 2, we show a small example of a ParBN. Fig. 3 then presents its asynchronous semantics for selected subset of parametrisations.

In general, the size of the set of all possible parametrisations (*parameter space*) can be even doubly-exponential in the number of Boolean variables. In particular, the number of Boolean functions in a model with n variables is 2^{2^n} . It is thus critical to restrict the parameter space as much as possible. In many biological models, regulations are usually supplemented with static constraints limiting their outcomes [21, 22].

We already presented observability, activation and inhibition as specific properties of regulations. In a parametrised setting, these properties can be used as constraints to restrict the parametrisation space. We assume that every regulation in a ParBN can be marked with a subset of these three constraints. Then for all $p \in P$ of $\widehat{\mathcal{B}}$, $\widehat{\mathcal{B}}_p$ must adhere to these constraints, e.g. a regulation marked observable in $\widehat{\mathcal{B}}$ must be observable in $\widehat{\mathcal{B}}_p$ and the same for activation and inhibition.

In Fig. 2a, a ParBN is displayed where all regulations are marked as either activating or inhibiting. Figures 2b and 2c then show the possible update functions satisfying these static constraints together with the corresponding logical parameters. Note that the fully parametrised model would have 16 parameters and 65536 parametrisations, but by applying the static constraints, only 27 parametrisations remain valid, significantly reducing the size of the associated edge-coloured graph.

2.2.2 Attractors

Notice that the standard notion of an attractor cannot be directly transferred to ParBNs, because a state can belong to an attractor only in certain parametrisations (for different parametrisations, the attractors do not have to overlap). We say that a subset $A \subset \Pi(\widehat{\mathcal{B}})$ is an *attractor in a parametrisation* $p \in P$ if A is an attractor of $\widehat{\mathcal{B}}_p$. Furthermore, given a state s , we can define $Ap(s)$ as the subset of P , such that for each $p \in Ap(s)$, $Att_p(s) \neq \emptyset$.

3 Control Problem for Parametrised Boolean Networks

A computational model is controllable if we can assure that from some initial state, it reaches a desired final state in a finite amount of steps. This property was well-studied in the context of synchronous BNs and is also being pioneered for asynchronous BNs. However, the control problem for ParBNs has not been explored yet. ParBNs offer a more flexible representation of biological systems by allowing some uncertainty in the specification of the logic behind regulations. Since in reality information on regulatory mechanisms is typically ambiguous or unknown, studying the control problem for ParBNs enables new attractive, real-life applications, such as the discovery of candidate transcription factors for cell reprogramming (i.e., to change a cell's phenotype) when the model is not fully known.

3.1 Control Problem for Boolean Networks

There are multiple ways to control the behaviour of a BN, mainly differentiated between *state* and *function* perturbations. State perturbations force the system to change its current state. Alternatively, function perturbations adjust the update function(s) and therefore modify the edges of the system's state-transition graph. Typically, changing the processes in a cell (function perturbation) is more difficult than artificially adding or extracting a biochemical substance (state perturbation). For this reason, this paper focuses on state perturbations.

State perturbations can be further differentiated based on their temporal characteristics, mainly *one-step*, *sequential*, *temporary*, and *permanent* control. In one-step control, we change the values of the controlled variables once, and then the network evolves as originally defined. Sequential control identifies a sequence of perturbations that are applied at different time steps. When applying the control temporarily, there exists a finite amount of computational steps after which the control is released. Finally, the most intrusive control is permanent control of variables. However, this scenario is rather unrealistic in practice, as the given substance would need to be added or extracted forever. Moreover, the permanent perturbation might disrupt the original long-term behaviour of the network or introduce completely new behaviours.

Finally, we consider different control objectives, defined in [7] as follows:

1. *Source-target control*: Given a *source state* $s \in \Pi(\mathcal{B})$, and a *target attractor* $T \in \mathbb{A}$, find such control that when applied, the BN always converges from the state s to the attractor T .
2. *Target control*: Given a *target attractor* $T \in \mathbb{A}$, find a control for every *source attractor* $S \in \mathbb{A}$ (such that $S \neq T$) that when applied, the BN converges from S to T .
3. *Full control*: For all pairs of distinct attractors $S, T \in \mathbb{A}$, find a control which guarantees that the BN converges from S to T .
4. *All-pairs control*: Given a subset of source attractors $\mathcal{S} \subseteq \mathbb{A}$ and target attractors $\mathcal{T} \subseteq \mathbb{A}$, for every pair $S \in \mathcal{S}$ and $T \in \mathcal{T}$, find a control which guarantees that the BN converges from S to T .

In some cases, one may also choose when the control is applied. Here, we consider *immediate* control, i.e. the control applied to the given state. Alternatively, during *sequential* control, the perturbations can be applied multiple times at

different time points. This way we can sometimes control the system using fewer perturbations. However, this approach brings new issues, such as dealing with the non-determinism of the BN (different perturbations may be necessary in different branches of the non-deterministic network's behaviour). Moreover, we would need to be able to precisely observe current state of the BN currently. These issues can be addressed to some extent using *attractor-based sequential* approach [17].

In summary, the control problems for BNs differ in the following aspects:

- *What do we want to control; goal:* What is the initial state of the BN? Where we want to end? Do we want to control only one scenario or multiple scenarios?
- *What control we apply:* We can either perturb states (once, temporarily, forever) or functions of variables;
- *When we apply control:* Only once from an initial state in contrast with applying control to an arbitrary state and any amount of times.

3.2 One-step Control Set of Parametrised Boolean Networks

In this paper, we focus on state perturbations applied immediately in the initial state. This is the elementary way to perturb the system when solving the source-target control problem. The respective notion of one-step control is stated formally in the following definition.

Definition 3.1 (One-step control of ParBN). Given a ParBN $\widehat{\mathcal{B}}$, a *one-step state perturbation control* C (further referred simply as *control*) is a tuple $(\mathbf{1}, \mathbf{0})$ where $\mathbf{1}, \mathbf{0} \subseteq \mathcal{V}$, $\mathbf{0}$ and $\mathbf{1}$ are mutually disjoint (possibly empty) subsets of variables of $\widehat{\mathcal{B}}$. The set of all possible controls is denoted \mathbb{C} . An *application of control* C to a state s , denoted $C(s)$, results in a state s' defined as:

$$s'(v) = \begin{cases} 1 & v \in \mathbf{1} \\ 0 & v \in \mathbf{0} \\ s(v) & \text{otherwise} \end{cases}$$

The *size of C* is defined as $\text{Size}(C) = |\mathbf{1}| + |\mathbf{0}|$.

Next we focus on establishing the control problem (when computing the one-step perturbation control) in ParBNs. Conceptually, the parametrised control problem is to some extent similar to the *parameter synthesis* problem. The goal of parameter synthesis is to find parametrisations that ensure some desired behaviour in the network. Such behaviour can also involve reachability of specific attractors. However, the key distinction between parameter synthesis problem and control problem is that in control, one determines perturbations that lead to a particular objective (with respect to given parametrisations), possibly resulting in behaviour that is not achievable only by tuning the network parameters. In this work, we thus treat parameters as unknown properties of the system rather than components that can be influenced.

One of the greatest challenges of ParBN control is that the attractors change based on the parametrisation. To that end, it makes sense to solve the control problem only for parametrisations which admit the given attractor. The parametrised control problem then computes a mapping that associates a potential control with the maximal set of parametrisations for which the control is applicable (the so-called controlled parametrisations). Formally, the considered parametrised control problem is stated in the following definition.

Definition 3.2 (Source-target control in ParBN). Given a ParBN $\widehat{\mathcal{B}}$, a source state s and a target state t , find a mapping $Cp : \mathbb{C} \rightarrow 2^{Ap(t)}$ which assigns each control $C \in \mathbb{C}$ a maximal (possibly empty) set of parametrisations p for which when C is applied, $\widehat{\mathcal{B}}_p$ converges from s to $Att_p(t)$. We refer to $Cp(C)$ as the *control enabling parametrisations* for C .

Intuitively, control enabling parametrisations $Cp(C) = p$ are the parametrisations, for which the target state is achieved by applying C in the non-parametrised case. Notice, that source-target problem in context of ParBN is aiming to drive the network into a target *state* of some attractor instead of an attractor itself. This is because parameterisations might contain attractors which are considered similar as all of them contain the given state. Therefore, in all parameterisations $Ap(t)$ the given state t is entered infinitely often by the controlled BN. If this is not the case of some ParBN and some parameterisations contain attractors which are out of the interest, the set of parameterisations $AP(t)$ might be replaced with an arbitrary one.

It is worth noting that it is always possible to bring the system into the given target state by setting the ParBN's variables to the values adequately (with the values of the given target state). We call this control *trivial*. However, when controlling a system, we typically look for a control which requires the fewest interventions as possible. Therefore, we want to

minimise the number of the controlled variables and the trivial solution might not be optimal. In a non-parametrised setting, this is typically the only considered optimisation criterion.

In a ParBN, the situation is further complicated due to the dependence on the parameters. To reach some attractor, it is sufficient to reach its strong basin after the application of a control. Nonetheless, the strong basin of an attractor can vary according to the parametrisation, and the control thus "works" only for its control enabling parametrisations. We are interested in maximal sets of control enabling parametrisations. To that end, we consider the notion of robustness that normalizes the number of control enabling parametrisations.

Definition 3.3 (Robustness of control). Given a ParBN $\widehat{\mathcal{B}}$, a target state t , a control set C and $Cp(C)$, the *robustness of control* C is defined as the ratio between the number of control enabling parametrisations and the number of all relevant parametrisations:

$$Rob(C) = \frac{|Cp(C)|}{|Ap(t)|}$$

Unfortunately, it is not always possible to ensure that some control is both minimal and the most robust. For example, there may be a control set C small in size, which only works for a small fraction of the parameter space. Consequently, while C is easily applicable, it may be unlikely to work in reality, as the real behaviour of the system can also follow one of the parametrisations which are not controlled by C . We discuss this issue in more detail in Section 5.

4 The Algorithmics

We are now ready to describe our computational framework for solving the one-step state perturbation control of ParBN. We start by introducing our approach for finding strong basins in a ParBN. Then we explain the framework for exploring ParBN's STG and for manipulation with ParBN's parametrisations. Finally, we build a concise workflow for ParBN control employing the proposed algorithms.

4.1 Semi-symbolic Parametrised Strong Basin Search Algorithm

We assume the set of parametrisations of a ParBN is represented as a reduced ordered binary decision diagram (BDD) [6]. The decision variables of the BDD are the parameters of the network (\mathcal{P}), meaning that every path from the root to a leaf in such a BDD represents a parametrisation of the ParBN. Common logical operations on such BDDs (and, or, negation, ...) then correspond to set operations (intersection, union, complement, ...). Furthermore, static constraints (activation, inhibition, observability) can be formalised using Boolean formulae over \mathcal{P} , and we can, therefore, create a BDD which enforces all imposed constraints and represents the set of all valid parametrisations.

Recall that we represent $Async(\widehat{\mathcal{B}})$ as an edge-labelled state-transition graph, where each transition $s \rightarrow t$ has an associated set of parametrisations $P(s, t) \subseteq P$ represented as a BDD. A *parametrised state set* is a mapping $\Pi(\widehat{\mathcal{B}}) \rightarrow 2^P$ assigning to each state a set of parametrisations. Furthermore, we suppose that the state space is represented *explicitly*, meaning that all operations on states are performed element-wise (typically in parallel).

We consider parametrised reachability procedures — given a source state s and a parameter set P , these procedures compute a maximal parametrised state set of all forward/backward reachable states from the source state s (containing all reachable states t where each t is associated with a maximal set of parametrisations P_t for which t is reachable from s):

$$\begin{aligned} forwardReachability(s, P) &= \{t \mapsto P_t \mid \forall p \in P_t : p \in P \wedge s \xrightarrow{p}^* t\} \\ backwardReachability(s, P) &= \{t \mapsto P_t \mid \forall p \in P_t : p \in P \wedge t \xrightarrow{p}^* s\} \end{aligned}$$

The chosen representation (explicit state space and symbolic parametrisations) allows to compute the reachability procedures in parallel. For the underlying implementation, we are working with internal libraries of the tool Aeon [23] which provides the most of the necessary functionality, including a convenient format for specifying ParBNs and parallel reachability procedures.

The key observation for controlling ParBNs is that an attractor (by definition) is always reached from its strong basin. From all other states, it is possible to reach also some other attractor(s); therefore, reaching the target attractor is not guaranteed. When the attractor's strong basin for all parametrisations is known, we can compute the control mapping

Cp from a source state to the target attractor by considering Hamming differences between the source and the states of the strong basin.

Our algorithm is based on the fixed-point approach for strong basin computation in non-parametrised BNs [24]. The premise is that only states from which it is possible to reach the attractor (weak basin) can be part of the strong basin. The weak basin of the attractor is computed using some standard reachability algorithms, for example, BFS. Then states are iteratively removed if it is possible to leave the basin from them (and therefore not reach the given attractor). Finally, if there are no states left to remove, the fixed-point is achieved, and the strong basin is found.

For parametrised control, we first need to determine $Ap(t)$ for the target state t , since in all other parametrisations, t is not a part of an attractor. This process is described in Algorithm 1. In Algorithm 2, we then extend the approach from [24] onto ParBN. For each state we remember under which parametrisations it is in the basin, starting with the parametrised weak basin. Then we iterate over the basin's states. For each state, we consider its successors, and we compute the parametrisations for which some successor is *not in the strong basin*. In these parametrisations, it is possible to leave the basin, and therefore these parametrisations are not part of the strong basin, and so we remove them for this state. We can process the states in parallel and compute for them the parameterisations which are not part of the strong basin. To avoid writing of the strong basin structure while it is intensively read from, we store the parameterisation which should be removed separately and after it is computed, we update the strong basin structure sequentially. The procedure is iterated until nothing more can be removed from the strong basin.

Algorithm 1: Compute attractor parametrisations $Ap(\text{target})$.

```

Input :PBN  $\widehat{B}$ , target attractor state target
Output :Attractor parametrisations  $Ap(\text{target})$ 

fwd  $\leftarrow$  forwardReachability(target, P);
bwd  $\leftarrow$  backwardReachability(target, P);
/* For every state, compute the BDD difference */
notAttractor  $\leftarrow$  fwd  $\setminus$  bwd;
return  $P \setminus \bigcup_{s \in \Pi(\widehat{B})} \text{notAttractor}(s)$ ;

```

Algorithm 2: Compute strong basin for an attractor in parallel.

```

Input :PBN  $\widehat{B}$ , a state target, attractor parametrisations  $Ap(\text{target})$ 
Output :parameterised state set  $\Pi(\widehat{B}) \rightarrow 2^{Ap(\text{target})}$  representing the strong basin

SB  $\leftarrow$  backwardReachability(target,  $Ap(\text{target})$ );
to_update  $\leftarrow$  s in  $\{s \in \Pi(\widehat{B}) \mid SB(s) \neq \emptyset\}$ ;
do
  updated  $\leftarrow$   $\emptyset$ ;
  to_remove  $\leftarrow$   $\forall s \in \Pi(\widehat{B}) \rightarrow \emptyset$ ;
  parallel for to_update do
    for t in successors(s) do
      /* Recompute parametrisations leading outside of basin */
      to_remove(s)  $\leftarrow$  SB(s)  $\cap$  P(s, t)  $\cap$  (P  $\setminus$  SB(t));
      if to_remove(s)  $\neq$   $\emptyset$  then
        | updated  $\leftarrow$  updated  $\cup$  {s};
  to_update  $\leftarrow$   $\emptyset$ ;
  for t in updated do
    /* Update strong basin */
    SB(s)  $\leftarrow$  SB(s)  $\setminus$  to_remove(s);
    /* Only predecessors of updated vars might be updated in the next iteration */
    to_update  $\leftarrow$  to_update  $\cup$  predecessors(s);
while to_update  $\neq$   $\emptyset$ ;
return SB;

```

4.2 Control Computation Workflow

Now we can describe a complete workflow for computing the source-target control in ParBNs, depicted in Fig. 4. The workflow consists of three inputs and three computation steps, resulting in the control mapping C_p .

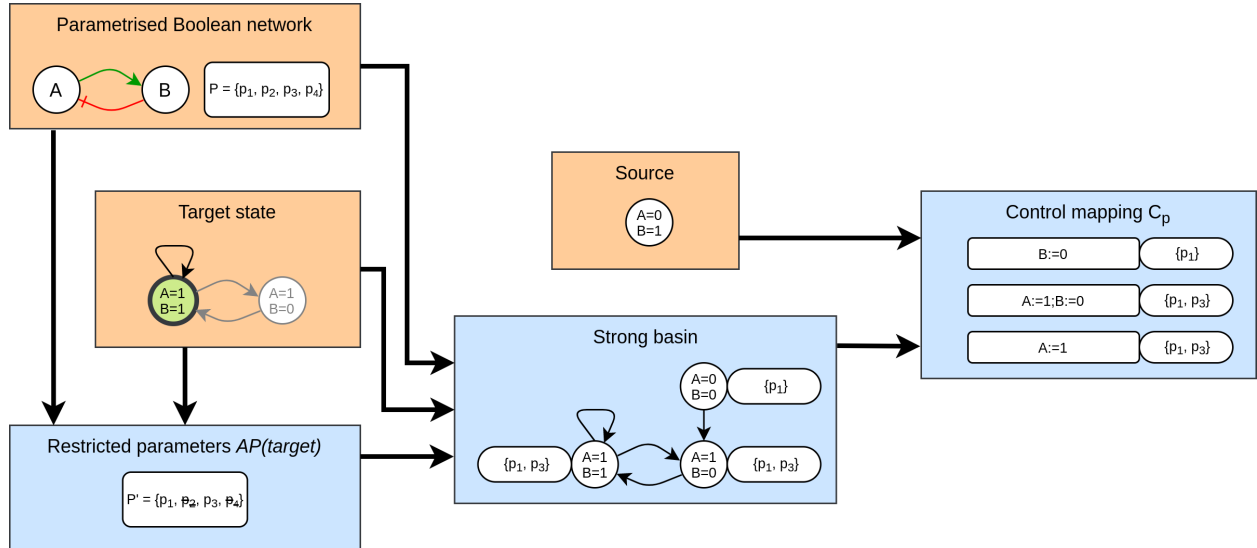

Figure 4: Workflow of computing the source-target control problem.

Given an input ParBN and a target attractor state $target$, we start by computing valid parametrisations set $Ap(target)$ using Algorithm 1. Then, the parametrised strong basin is computed from the ParBN with target attractor state $target$ and its valid parametrisations $Ap(target)$ using Algorithm 2. After that, from the strong basin and the source state, we obtain the complete control mapping. Notice that we do not need to know the source state for computing the strong basin and that we can re-use the target’s strong basin for obtaining control for different sources.

To compute the control mapping, observe that viable controls correspond exactly to the Hamming differences (the variables with opposite values) between the source state and the states of the strong basin; yielding one viable control C for every state s in the strong basin SB. Any other control C' does not reach the strong basin and therefore does not guarantee to reach the target attractor (for these, $Cp(C') = \emptyset$). A control C is then viable only for parametrisations for which s appears in the strong basin, we thus set $Cp(C) = SB(s)$.

Finally, we can compute the size and robustness of each control as we have all knowledge regarding the variables which need to be controlled and for which parametrisations the controls work. If it is desired, we can construct a *witness* BN for a control C (a non-parametrised BN where the given control works) by fixing some parameter from $Cp(C)$. The prototype implementation containing all parts of the workflow is available¹.

In highly parametrised models, it is not unusual to obtain a control with size 0, where in some parametrisations no action would be needed to control the model. This is because, in some parametrisations, the source might already be a part of the target’s strong basin. If this case is considered unrealistic (since there is probably a need for control, thus these parametrisations appear to be invalid), the parametrisations $Ap(target)$ can be replaced with a custom set of parametrisations.

The resulting set of all available controls can be then used for e.g. cell reprogramming. However, we might obtain many possible controls, and we need to decide which one should be applied. To do that, we can decide based on the size of control or its robustness. The control set can be arbitrarily filtered discarding controls with size bigger than the trivial control (which always has 100% robustness) or bigger than some set size. Similarly, the control set can be pruned based on too low robustness. The interplay of these two factors is non-trivial, and it is left to the actual application to decide which control would best suit its needs.

5 Evaluation

We evaluate our approach on two real-life BN models. We compare the performance of our approach using a different number of parameters implanted into the models, resulting in different size of relevant parameter space. We conducted

¹<http://github.com/sybila/biodivine-pbn-control>

all measurements using a machine equipped with AMD Ryzen Threadripper 2990WX 32-Core Processor and 64GB of memory.

The first model is a *cell-fate decision model* [25]. The model provides a high-level view of possible different cell fates such as pro-survival, necrosis or apoptosis. We used a fully-parametrised version (all update functions are completely parametrised) of this model and we selected seven biologically relevant attractors. We computed strong basins only for these attractors in several parametrised versions of the model differing in the number of unknown parameters (see Table 1).

The second model, a *myeloid differentiation network* [26], was designed to model a muscle tissue cell differentiation from common myeloid cell to specialised muscle cells (megakaryocytes, erythrocytes, granulocytes and monocytes). The original non-parametrised network has eleven nodes and six attractors. We derived several parametrised versions of the model by arbitrarily parametrising update functions of the model. Similarly to the previous case, we used only attractors of the original network when computing strong basins for parametrised versions of the model. The results are again shown in Table 1.

Table 1: Results of strong basins computation. The values are stated as ranges because we computed strong basins of all attractors considered in given models. The second column shows the number of model’s parameters. The third column shows count ranges of parametrisations which contain the given attractor. The fourth (resp. fifth) column displays ranges of the number of states in the weak (resp. strong) basins. The last column contains ranges of times needed to compute strong basins.

Model	$ \mathcal{P} $	$ Ap(t) $	# WB states	# SB states	Time
Cell-Fate	1	1	258,000 – 491,184	32 – 352	4.4 – 9.19 s
	8	1 – 4	258,000 – 491,464	21 – 79	4.63 – 13.42 s
	20	7 – 56	258,048 – 491,520	1632 – 262,144	5.82 – 26.59 s
Myeloid	1	1	128 – 1,152	64 – 384	8 – 30 ms
	32	63 – 2,052	224 – 1,984	64 – 1,472	14 – 214 ms
	70	$5.9 \times 10^4 – 1.8 \times 10^7$	1,512 – 2,048	256 – 2,048	147 – 1717 s
	94	$3.4 \times 10^6 – 3.7 \times 10^9$	2,008 – 2,048	1,024 – 2,048	0.6 – 15.38 s

Next, we “virtually” compare our approach to the naïve parameter-scan approach. In [7], a strong basin of (non-parametrised) asynchronous BNs is computed using a block decomposition method with 4 ms needed to finish the computation for the *myeloid model*. Even if the reported HW was slower than in our case and we assume that the strong basin computation for one parametrisation would last only 1 ms, the fully parametrised myeloid model contains an attractor which is present in 3.7×10^9 parametrisations. Therefore, the expected time for computing a strong basin for all parametrisations with 32-fold parameterisation would last more than a day compared to less than 27 seconds achieved using our parameter-based semi-symbolic approach.

We evaluate the scalability of our approach on a fully parametrised myeloid model. The results are shown in Table 2. The computation was restricted to the specified amount of CPUs. The final speed-up achieved on our machine, when using 32 CPUs compared to a non-parallel CPU usage was about 10-fold.

Table 2: Scalability of strong basin computation. The strong basins are computed on attractors of myeloid model .

# CPUs	Attractor 1	Attractor 2	Attractor 3	Attractor 4	Attractor 5	Attractor 6
1	6.13 s	99.31 s	71.32 s	130.17 s	45.84 s	136.65 s
2	3.34 s	54.32 s	38.87 s	71.31 s	24.95 s	74.29 s
4	1.86 s	31.3 s	21.83 s	40.31 s	13.71 s	42.26 s
8	1.11 s	19.34 s	13.31 s	24.68 s	8.4 s	26.49 s
16	0.87 s	14.03 s	9.32 s	17.56 s	5.77 s	18.86 s
32	0.6 s	10.98 s	6.87 s	13.22 s	4.54 s	15.38 s

Now let us have a look at an example of how the results might be interpreted and an suitable control selected. Suppose that we want to reprogram an erythrocyte cell (phenotype having factors EKLf=1 and GATA-2=0) into a monocyte cell (phenotype having factors cJun=1 and EgrNab=1) of the myeloid model. First, we obtain a strong basin of the monocyte attractor having 1472 states yielding us 1472 possible control sets. We can observe, that trivial; i.e., the most robust control strategy (setting variables so that we reach the attractor right after applying the control) has size 8. We can discard all controls with bigger size 8 and bigger as they are less optimal in all aspects than the trivial control. In our case, there are 1259 controls with smaller size than the trivial one.

Resulting smallest control sets have the size 1. However, the best robustness among these controls is 46%. Therefore, it is quite likely that it will not work in the practice; for a real cell. If we allow the control to have the size 2, we can

use the control with 76.8% robustness. Further increasing the size provides control with the size 3 and the robustness 92% and so is highly likely to reprogramm the cell’s phenotype. To achieve only slightly more robustness (93.8%) we need to use a control of the size 5. In this highly parametrised model, there is no control with 100% robustness being smaller than the trivial one. It is not a rule of the thumb that with bigger size of control we obtain better robustness, for example, the control with the size 11 (the only one, with all variables, reversed compared to the original one) has the robustness of only 50%.

It can be seen that the unknown properties of ParBN make selection of one particular “best“ control complicated. That is why a careful in vitro experimentation is needed to verify the correctness of the control in the reality. Nonetheless, the obtained control set still can help and highly reduce the exponential number of potential transcription factors combinations.

6 Conclusion

We have introduced the control problem for parametrised Boolean networks and we proposed an algorithm for solving the source-target variant of this problem using one-step perturbations. The core procedure of the algorithm is a fixed-point computation of the parametrised strong basin of the given target. The method we proposed is semi-symbolic – it relies on a unique integration of symbolic (based on BDD representation) and explicit (based on enumerative model checking) formal methods. We demonstrated that our approach is capable to control highly parametrised models in seconds. Owing to the doubly-exponential explosion of the number of possible parametrisations, such a result cannot be achieved with the naïve parameter scan approach.

In the future work, we would like to scale up the algorithm for searching the strong basin, i.e., by using some symbolic approach for exploring ParBN’s state transition graph. Moreover, we would like to consider other variants of ParBN control problems based on variants of non-parametrised control problems (see Subsection 3.1). Last but not least, we would like to incorporate the developed methods into an existing ParBN toolkit – the AEON tool [23].

References

- [1] Julian D. Schwab, Silke D. Kühlwein, Nensi Ikononi, Michael Kühl, and Hans A. Kestler. Concepts in boolean network modeling: What do they all mean? *Computational and Structural Biotechnology Journal*, 18:571 – 582, 2020.
- [2] D. Zheng, G. Yang, X. Li, Z. Wang, F. Liu, and L. He. An efficient algorithm for computing attractors of synchronous and asynchronous boolean networks. *PLOS ONE*, 8, 04 2013.
- [3] Yi Ming Zou. Boolean networks with multiexpressions and parameters. *IEEE/ACM Transactions on Computational Biology and Bioinformatics*, 10:584–592, 2013.
- [4] Nikola Beneš, Luboš Brim, Samuel Pastva, Jakub Poláček, and David Šafránek. Formal analysis of qualitative long-term behaviour in parametrised boolean networks. In Yamine Ait-Ameur and Shengchao Qin, editors, *Formal Methods and Software Engineering*, pages 353–369, Cham, 2019. Springer International Publishing.
- [5] Rui-Sheng Wang, Assieh Saadatpour, and Reka Albert. Boolean modeling in systems biology: an overview of methodology and applications. *Physical biology*, 9(5):055001, 2012.
- [6] Randal E. Bryant. Graph-based algorithms for boolean function manipulation. *IEEE Trans. Computers*, 35(8):677–691, 1986.
- [7] Alexis Baudin, Soumya Paul, Cui Su, and Jun Pang. Controlling large Boolean networks with single-step perturbations. *Bioinformatics*, 35(14):i558–i567, 07 2019.
- [8] Sang-Min Park Junil Kim and Kwang-Hyun Cho. Discovery of a kernel for controlling biomolecular regulatory networks. *Nature Sci Rep*, 3(2223), 07 2013.
- [9] Bernold Fiedler et al. Dynamics and control at feedback vertex sets. i: Informative and determining nodes in regulatory networks. *J. Dyn. Differ. Equ.*, 25(3):563–604, 2013.
- [10] Yin Zhao, Bijoy K Ghosh, and Daizhan Cheng. Control of large-scale boolean networks via network aggregation. *IEEE Trans. on Neural Networks and Learning Systems*, 27(7):1527–1536, 2015.
- [11] Mohammad Moradi, Sama Goliaei, and Mohammad-Hadi Foroughmand-Araabi. A boolean network control algorithm guided by forward dynamic programming. *PLOS ONE*, 14:1–21, 05 2019.
- [12] Jorge G. T. Zañudo and Réka Albert. Cell fate reprogramming by control of intracellular network dynamics. *PLOS Computational Biology*, 11(4):1–24, 04 2015.

- [13] Sean P Cornelius, William L Kath, and Adilson E Motter. Realistic control of network dynamics. *Nature communications*, 4(1):1–9, 2013.
- [14] Hugues Mandon, Stefan Haar, and Loïc Paulevé. Temporal reprogramming of boolean networks. In *CMSB*, volume 10545 of *LNCS*, pages 179–195. Springer, 2017.
- [15] Cui Su and Jun Pang. A dynamics-based approach for the target control of boolean networks. *CoRR*, abs/2006.02304, 2020.
- [16] Wassim Abou-Jaoudé, Pauline Traynard, Pedro T. Monteiro, Julio Saez-Rodriguez, Tomáš Helikar, Denis Thieffry, and Claudine Chaouiya. Logical modeling and dynamical analysis of cellular networks. *Frontiers in Genetics*, 7:94, 2016.
- [17] Hugues Mandon, Cui Su, Stefan Haar, Jun Pang, and Loïc Paulevé. Sequential reprogramming of boolean networks made practical. In Luca Bortolussi and Guido Sanguinetti, editors, *Computational Methods in Systems Biology*, pages 3–19, Cham, 2019. Springer International Publishing.
- [18] Jérémie Pardo, Sergiu Ivanov, and Franck Delaplace. Sequential reprogramming of biological network fate. In *CMSB*, pages 20–41. Springer, 2019.
- [19] Cui Su and Jun Pang. Sequential control of boolean networks with temporary and permanent perturbations. *CoRR*, abs/2004.07184, 2020.
- [20] Wassim Abou-Jaoudé, Djomangan A Ouattara, and Marcelle Kaufman. From structure to dynamics: frequency tuning in the P53–MDM2 network: I. logical approach. *Journal of theoretical biology*, 258(4):561–577, 2009.
- [21] Hannes Klarner. *Contributions to the Analysis of Qualitative Models of Regulatory Networks*. PhD thesis, Free University of Berlin, 2015.
- [22] Adam Streck. *Toolkit for reverse engineering of molecular pathways via parameter identification*. PhD thesis, Free University of Berlin, 2016.
- [23] Nikola Beneš, Luboš Brim, Samuel Pastva, and David Šafránek. AEON: attractor bifurcation analysis of parametrised boolean networks. In *Computer Aided Verification - 32nd International Conference, CAV 2020*, volume 12224 of *Lecture Notes in Computer Science*, Cham, 2020. Springer International Publishing.
- [24] Soumya Paul, Jun Pang, and Cui Su. On the full control of boolean networks. In *CMSB*, 2018.
- [25] Laurence Calzone, Laurent Tournier, Simon Fourquet, Denis Thieffry, Boris Zhivotovsky, Emmanuel Barillot, and Andrei Zinovyev. Mathematical modelling of cell-fate decision in response to death receptor engagement. *PLOS Computational Biology*, 6(3):1–15, 03 2010.
- [26] Jan Krumsiek, Carsten Marr, Timm Schroeder, and Fabian J. Theis. Hierarchical differentiation of myeloid progenitors is encoded in the transcription factor network. *PLOS ONE*, 6(8):1–10, 08 2011.