

Magnonics and Supermagnonics

Yury Bunkov

Russian Quantum Center, Skolkovo, Moscow, 121205, Russia.

The magnetic community continues to discuss the possibility to observe the magnetic superfluidity, despite the fact that it has been discovered long time ago. It was observed in antiferromagnetic states of superfluid ^3He in 1984. In this article we remind the main principles of spin superfluidity and related Bose-Einstein magnon condensation. We discuss applications of this phenomenon in supermagnonic devices.

PACS numbers:

Keywords: Supermagnonics, spin supercurrent, magnon BEC, YIG.

SPIN CURRENT AND SPIN SUPERCURRENT

The magnetically ordered systems characterized by an order parameter, which is the result of spontaneous breaking of spin-orbit $SU(2)$ symmetry in the equilibrium magnetic states. These states show the rigidity with respect to the inhomogeneous spin rotations $\theta_\alpha(\mathbf{r})$ i.e. to the dependence of the energy on the gradients $\omega_{\alpha i} = \nabla_i \theta_\alpha$. This rigidity leads to formation of spin waves (the collective oscillations of magnons) and spin transport in magnetic textures. Particularly the flow of magnetization can circulate in the case of topological defect in magnetically ordered materials. The spatial spin current can be excited also by pumping of magnetization in one side of the sample and its sink in the other side. The experimental observation of this current is discussed for a long time. See [1–3] and references there. The spin current in this case is proportional to the gradient of order parameter. Indeed its nature is very different from an origin of superfluid and supercurrent phenomena. Let us consider the analogy with the cosmology. The ground state of the Universe - the quantum vacuum is the ordered state described by a complex matrix. The gradients of this state lead to a flow of vacuum, particularly in the case of cosmic strings. Similar cases take place in magnetically ordered states. The gradient of ground state leads to a flow of magnetization. Can we call this flow a supercurrent? Yes and No. From one side the gradient of ground state leads to the flow of magnetization. But originally the term superfluidity and superconductivity applied for the flow of excitations and not a flow due to the gradient of ground state - quantum vacuum.

This difference is very clear in magnetically ordered systems. There is a ground state and excitations - magnons. Physicists usually deal with the dynamics of magnetic ground state at a small excitation described by Landau-Lifshits equations. But the situation drastically changes in the case of a big density of magnons. In this case magnons may form a Bose-Einstein condensate, which gradient leads to a spin supercurrent in full analogy with mass superfluidity and superconductivity. This

type of flow has all rights to be called supercurrent while the flow of magnetization in the case of magnetic texture of ground state we can call textural current.

Since magnons obey the Bose statistics, they may form Bose-Einstein condensate (BEC) similar to an atomic BEC. Atoms form a coherent quantum state at the temperature below a critical one for given density of atoms. These conditions were predicted by Einstein [4] and follow from Bose statistics:

$$T_{BEC} \simeq 3.31 \frac{\hbar^2}{k_B m} (N_C)^{2/3}, \quad (1)$$

where N_C is the density of atomic gas and T_{BEC} is the critical temperature, below which atoms condense in a BEC state. The magnon BEC state should form at about the same ratio between the temperature and density. Magnons condensed to a Bose-Einstein condensate at a higher density.

Indeed, magnons have a finite lifetime and the total number of equilibrium magnons decreases with decreasing of temperature (and reach zero at $T = 0$). The density of magnons at thermodynamic equilibrium is always below the critical density of magnons BEC formation. However, the density of excited non-equilibrium magnons N_M can be drastically increased up to about Avogadro density by a magnetic resonance method. The excited magnons can form the quasi-equilibrium excited state with a time scale of about few quasiparticles scattering time. The usual 4-magnon scattering conserves the total number of quasiparticles and holds the distribution function with the effective temperature T and effective chemical potential μ . The critical density of magnons BEC formation N_{BEC} can be estimated from equation (1). The initial temperature of magnons corresponds to phonon subsystem temperature, which determines the value of magnetization M and density of thermal magnons. We are able to increase the density of excited magnons above the critical one by dynamical magnetization deflection. Magnons should form a BEC state when $N_M > N_{BEC}$, under certain conditions, which will be discussed below. The critical magnons concentration N_{BEC} for ferro and antiferromagnets was calculated in [5, 6]. Particularly for

easy plain antiferromagnets with wave spectrum

$$\varepsilon_k = \sqrt{\varepsilon_0^2 + \varepsilon_{ex}^2 (ak)^2} \quad (2)$$

it reads:

$$N_{BEC} \simeq \frac{(k_B T)^2}{2\pi^2} \frac{\varepsilon_0}{a^3 \varepsilon_{ex}^3}. \quad (3)$$

The magnetic ordering in a magnon BEC state arises due to spontaneous breaking of $U(1)$ symmetry in the non-equilibrium magnon condensate. In atomic BEC and in helium superfluids such symmetry breaking leads to a non-zero value of the superfluid rigidity – the superfluid density ρ_s which enters the non-dissipative supercurrent of particles and thus to mass supercurrent. The same takes place for magnon BEC. The supercurrent of magnons can be described by traditional equations:

$$\mathbf{J} = \rho_s \mathbf{v}_s, \quad \mathbf{v}_s = \frac{\hbar}{m_M} \nabla \alpha, \quad \rho_s(T=0) = N_M m_M. \quad (4)$$

where m_M is the effective mass of magnons. In translationally invariant systems, where the mass current coincides with density of linear momentum, Eq.(4) can be obtained directly from the definition of linear momentum density in spin systems:

$$\mathbf{P} = (S - S_z) \nabla \alpha = N_M \hbar \nabla \alpha, \quad (5)$$

where we used the fact that density of magnons $N_M = S - S_z$ and phase of magnetization precession α are canonically conjugated variables. As in conventional superfluids, the superfluid density of the magnon liquid is determined by the magnon density N_M and magnon mass m_M . The superfluid mass current (4) carries magnons with mass m_M , while in atomic superfluids the superfluid mass current carries atoms. The magnon mass current generated by precessing magnetization in magnon BEC is similar to electric current generated by precessing magnetization in ferromagnets [7].

The best magnetically ordered spin systems for magnon BEC and spin supercurrent investigations are antiferromagnetic states of superfluid ^3He owing the very small Gilbert damping (about 10^{-9}), its absolute purity and different types of magnon-magnon interactions. It is very important to know that the dynamic properties of these states are the results of magnetic ordering and does not related with its mass superfluid properties [8].

SPIN SUPERFLUIDITY

In 1984 the first magnon BEC state and related spin superfluidity has been discovered in antiferromagnetic superfluid ^3He . The magnon BEC demonstrate the spontaneously self-organized phase-coherent precession of spins

[9, 10]. This state is radically different from the conventional ordered states in magnets. It is the quasi-equilibrium state, which emerges on the background of the ordered magnetic state, and which can be represented in terms of the Bose condensation of magnetic excitations – magnons [8].

The magnon BEC opened the new class of the systems, the Bose-Einstein condensates of quasiparticles, whose number is not conserved. Representatives of this class in addition to BEC of magnons are the BEC of phonons [11], excitons [12], exciton-polaritons [13], photons [14], rotons [15] and other bosonic quasiparticles.

Owing the coherence the magnon BEC radiates a very Long Living Induction Decay Signal (LLIDS). It may be considered as a time crystals [16] with a very long, but finite lifetime. It may reach minutes in antiferromagnetic superfluid $^3\text{He-B}$. Furthermore, the Goldstone modes – the time-space excitations of the time crystal (the analog of second sound in superfluid ^4He) have been observed in magnon BECs [17–19]. The lifetime of magnon BEC states may be infinite in the case, when the losses (evaporation) of quasiparticles are replenished by an excitation of new quasiparticles.

The formation of a magnon BEC state was first observed in antiferromagnetic superfluid $^3\text{He-B}$ [9, 20]. Usually, in the linear case, the induction decay signal after a RF pulse ringing the time, inversely proportional to an inhomogeneous broadening of magnetic system $\Delta\omega$. In the experiments, described in [9, 20] the induction signal also lost coherency at the time scale about $1/\Delta\omega$ but then spontaneously reappears and ringing a few orders of magnitude longer! The formation of LLIDS manifest itself the condensation of magnons in a common wave function in all the sample with a common phase and frequency of precession. The mechanism of BEC state formation related to a repulsive intersection between magnons. The higher local magnon density – the bigger dynamical frequency shift in the system. The local inhomogeneity of Larmore precession generates the gradient of phase of precession and, consequently, the superfluid transport of magnons. This spin supercurrent redistribute magnons until the dynamic frequency shift compensate the magnetic field inhomogeneity. The so named Homogeneously Precessing Domain (HPD) forms. The of coherently precession magnetization in HPD radiates LLIDS signal.

The LLIDS obey all the requirement for BEC of quasiparticles, which much later was postulated as an requirement of magnon BEC in well known article by Snoke [21]. Magnon BEC has one to one analogy with the experiments of atomic BEC [22]. Owing the slow magnons relaxation, the number of magnons decrease, but the magnons remains in a coherent state. It is important to note that the BEC state is the eigen state of excited magnons. It was shown experimentally, that the small RF pumping on a frequency of magnon BEC ω_{BEC} can compensate the magnons relaxation by creation of an

additional magnons. In this case the magnons BEC may maintains permanently for an infinite time [23]. The 35 years of magnons BEC investigations in different antiferromagnetic states of superfluid ^3He well established the physics of excited magnon BEC and phenomena of spin superfluidity. The review of this investigations one can found, for example in [24, 25] and in the book [8].

EXPERIMENTAL OBSERVATION OF SPIN SUPERCURRENT

The excitation of the homogeneously precessing domain is an interesting discovery in itself. The next step in investigations of the magnon BEC was the experimental studies of spin supercurrent between two independent HPD states, connected by a channel which was either perpendicular [15, 26, 27] or parallel to magnetic field [28]. The idea of these experiments was very straightforward and based on the analogy of a superconducting bridge between two massive superconducting electrodes. Here we can consider two cells filled with HPD as such electrodes. The role of the potential difference between the electrodes is equivalent to the difference of the HPD precession frequencies. This difference leads to an increase in the gradient of phase of precession in the channel and consequently to the growth of spin supercurrent. If one keeps the frequencies of HPD's precession the same, then the phase gradient in the channel remains constant and a steady state supercurrent has to pass through the channel. In the case of superconductivity this current is supplied by the leads of the normal metal, which have some resistance and consequently there is a voltage difference. In the case of the spin supercurrent the longitudinal magnetization is not conserved in the RF field. Therefore, the RF field can pump the longitudinal magnetization into one cell and pump it out in the other cell. The transport of the longitudinal magnetization along the channel in a magnetic field is accompanied by transport of Zeeman energy. This transport has been measured by the increase in one cell of the energy absorbed from the RF field with increasing phase difference, and its decrease in the other cell. In this way we were able to measure the current of longitudinal magnetization flowing out from one cell and into the other.

Owing to the direct relation between the phase of magnetization precession and the phase of the order parameter, we were able to control the spin supercurrent through measurement of the phase gradient of the magnetization precession in the channel. This method has no analogue with superconductivity because there is no field that is sensitive to the phase of the wave function of electron Cooper pairs.

The first observation of a spin supercurrent in the channel have been published in [15]. The experimental set-up consists of two cells in the form of a barrel

with axes parallel or perpendicular to the magnetic field, connected by a channel perpendicular to field (see Fig. 2). The cells were surrounded by RF coils, and copper shielding prevented interaction between the coils. The channel was surrounded by additional shielding to prevent RF field penetration into the channel. The coils 1 and 2 were used to excite HPD states in both cells and to control them. The frequency and phase of the precession of the domain with homogeneous precession in each of the volumes was determined by the frequency and phase of the radio-frequency field of the corresponding coil, supplied from separate highly stable generators. The cells were filled with HPD by sweeping down the magnetic field. When the domain boundary crossed the inlet to the channel, the HPD filled the channel. Miniature receiving radio-frequency coils 3 and 4 were set up in the channel, and received a signal from the precessing magnetization in the channel. A small signal induced by the exciting coils was compensated by an electronic circuit. For HPD creation, equal frequency and phase of both RF generators was chosen, so we can assume that the difference of phase of precession in the channel is zero. Then the frequency of one of the rf generators was changed by $\delta\omega \simeq 0.1\text{Hz}$. This causes the difference between phases of precession $\Delta\alpha$ to grow. A phase difference between two HPD's determines the phase gradient along the channel.

If we keep increasing this phase difference, the spins in the channel will "wind up" to maintain boundary conditions. The spin current in the channel increases, until it reaches a certain critical point, after which it drops by a certain, specified amount. Here, the mis-equationment of the spins is too great to warrant transfer, and locally the HPD is disrupted, and the spins in the channel "unwind". At this spot, the magnetisation will locally be equated parallel to the external magnetic field, and in this way "lose" several times 2π of twisting. Once the tenseness has gone out of the system, the spins re-equation with the surrounding precession angles, and the spiral reforms with a few windings less. If the precession phase difference is increased again, they will wind up until the critical value once more, as is shown by the measurement in Fig. 3 There is shown the rise of the absorption signal in cell 1 and its diminishes in cell 2. (Due to the symmetry, the signal from cell 1 at negative $\Delta\alpha$ corresponds to the signal from cell 2 at positive $\Delta\alpha$). This process corresponds to a transfer of longitudinal magnetization, and consequently the Zeeman energy, from one chamber to the other. All experimental curves correspond to stationary solutions in the channel. To check this, we made the frequencies of the HPD's equal at a certain time. Then the absorption signals from both HPD and gradient distribution in the channel did not change any more - a steady state spin supercurrent continued to flow along the channel.

With increasing $\Delta\alpha$ one can see that on reaching a critical phase difference $\Delta\alpha_c^+$ at point B the absorption

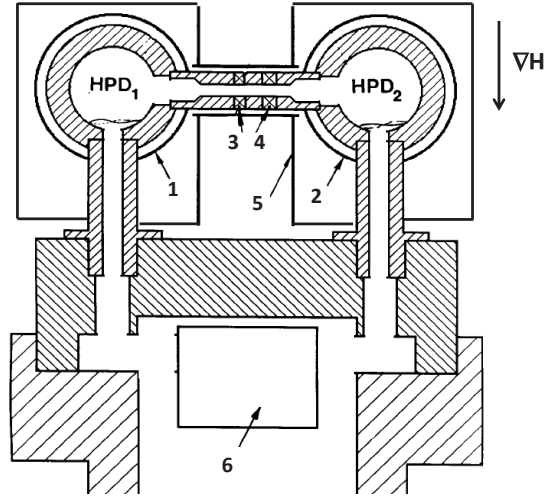

FIG. 1: The experimental cell for studies of spin supercurrent between two HPD states, excited by RF from two independent coils 1 and 2. The channel of 1.4 mm in diameter connecting HPD states. The pick up coils 3 and 4 monitoring the amplitude and phase of the magnetization precession inside the channel. Pt NMR thermometer (6) monitoring the temperature. The screen (5) suppress the RF crossover signal between the coils. The cells connected to a main volume of ^3He by a channels.

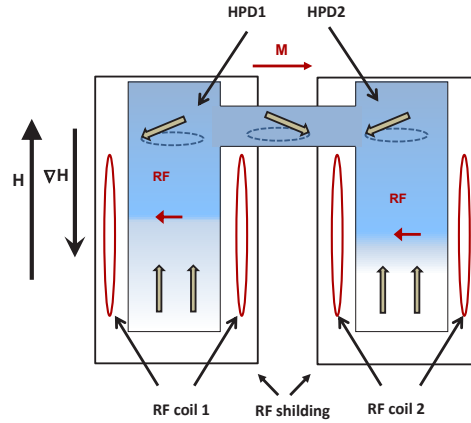

FIG. 2: Illustration of experimental observation of spin supercurrent between two HPD states. The spin supercurrent transport the magnetization from cell 1 to cell 2. The current is proportional to the gradient of phase of precession in the channel.

jumps to a smaller value (point C), then increases to the critical value again, etc. In this case the jumps occur with period $2n\pi$ in $\Delta\alpha$. The critical phase gradient determines by the inverse value of the Ginzburg-Landau coherence length.

$$\nabla\alpha_c^2 = 1/\xi_{GL}^2 = \omega_L(\omega_{RF} - \omega_L)/c_{\perp}^2. \quad (6)$$

Its increase with the increasing the difference $\omega_{RF} - \omega_L$. The value of phase slippage also increase. Experimentally the phase slip up to 16π have been observed. Similar jumps can be seen in the phase of precession in the chan-

nel. The gradient of the phase of precession in the channel produces a spin supercurrent which, for the channel perpendicular to H , reads:

$$J_P = -\frac{\chi}{\gamma}(1 - \cos\beta)[(1 - \cos\beta)c_{\parallel}^2 + (1 + \cos\beta)c_{\perp}^2]\nabla\alpha. \quad (7)$$

This supercurrent transports the longitudinal magnetization from cell 2 to cell 1. The rise of the magnetization in cell 1 means a decrease of the angle β . To maintain the resonance condition, the HPD in this cell begins to absorb more RF power (curve AB). The same supercurrent leads to an increase of angle β in cell 2. To prevent this

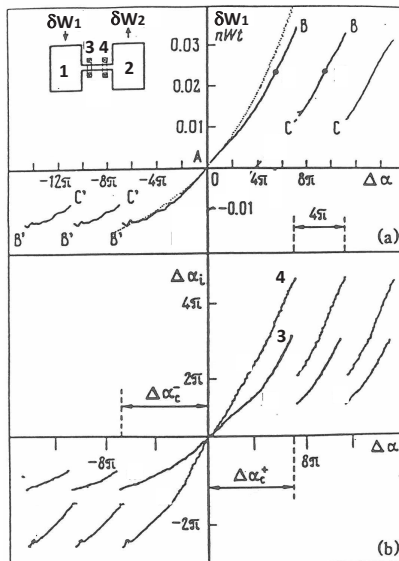

FIG. 3: The record of energy dissipation in both HPD's as function of phases of precession in HPD's and the phase of precession in pick-up coils 3 and 4. The spin supercurrent transport the magnetization from cell 1 to cell 2. The absorption of energy in cell 1 increase for to compensate the zeeman energy, transported out by spin supercurrent. This energy partly dissipate in the channel due to diffusion relaxation and partly arrive to cell 2. Consequently the energy, absorbed from the RF field in cell 2 decreasing. At point B the phase slippage of 4π appears. This critical spin current in the channel determins by $\omega - \omega_L$ and thus as a function of the coherence length ξ in (6). The signals from pick-up coils measured the phase distribution inside the channel.

the NMR absorption must fall in this cell (curve AB'). In other words the magnetic supercurrent transports some magnetic energy $J_E = -J_P H$ from cell 1 to cell 2. To compensate this energy flow the rf absorption rises in one cell by δW_1 and falls in the other one by $-\delta W_2$. If the magnetization transported by the supercurrent were conserved, we would have $\delta W_1 = -\delta W_2$. However, there are some relaxation processes caused by interaction between the magnetization of the normal and superfluid components. Spin diffusion of the normal component leads to a dissipation of magnetic energy in the channel, that grows with phase gradient. To maintain the resonance conditions for the HPD in the channel, the energy losses should be compensated by additional energy supply by spin supercurrent. So the spin current is greater at the inlet of the channel than at the outlet. The asymmetry of the experimental curve about $\Delta\alpha = 0$ is the result of magnetic relaxation within the channel. But this relaxation is not the result of friction, it can be treated as a relaxation of the eigenstate, which can not be seen in the case of mass superfluidity or superconductivity due to the conservation of mass and charge. By taking this relaxation into account one can recalculate the distribution of $\nabla\alpha$ along the channel:

$$\nabla\alpha(x) = \frac{\exp \Lambda \Delta\alpha - 1}{\Lambda [L + (\exp \Lambda \Delta\alpha - 1)x]} \quad (8)$$

where L is the length of the channel and $\Lambda = \frac{64}{145} D \omega_{RF} c_{\perp}^{-2}$, where $D = (D_{\parallel} + D_{\perp})/2$ is the effective spin diffusion coefficient along the channel as defined in [29]. With cooling this relaxation significantly decrease due to decrease of the normal component of liquid. Indeed, we was not able to investigate this phenomena at temperature below $0.4 T_C$ due to instability of HPD state, which was named "Catastrophic relaxation" [30].

PHASE SLIPPAGE.

The spin supercurrent in a channel is limited by the instability of current against phase slippage. In this section we shall analyse the nature of phase slip centres for spin supercurrent. From a general point of view the phase slippage of spin supercurrent is analogous to that observed in superconducting wires [31] and mass superflow through a small hole [32]. We have learned from these superfluidity and superconductivity experiments that the superfluid density should be zero at the phase slip centre. As a result the phase of the order parameter is not determined and the phase relation along the channel can have a discontinuity. The formation of phase slip is related to a change in some energy. If this energy is less, than the density of the kinetic (gradient) energy of the supercurrent, the phase slip appears. As a result of phase slippage the phase difference along a channel will be decres

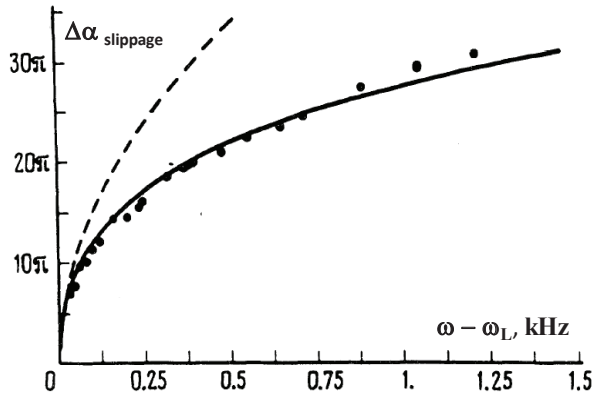

FIG. 4: Critical phase difference versus frequency shift in the channel, measured at 29.3 bar and 1.4 mK. Dashed curve represents the theory for nonrelaxing magnetization, while solid curve is the theoretical fit with spin-diffusion relaxation as a parameter.

on $2n\pi$. Upon decreasing the kinetic (gradient) energy density the phase slip centre becomes unstable and disappears. The main difference between phase slip in superfluidity and superconductivity and the phase slip of spin supercurrent is that in the latter case it is not necessary to destroy the superfluid state to create the phase slip. It is sufficient to destroy the spin supercurrent density which is proportional to $(1 - \cos \beta)$ (see (5.1)) to maintain the spin supercurrent phase slip centre. If $\beta = 0$ in any part of the channel, the phases of precession of the HPD in the cells are no longer connected and the phase difference between the two HPD's can change by a multiple of 2π . The critical current for creation of the phase slip can be estimated by comparing the stiffness of the HPD state in a channel and kinetic (gradient) energy of a current. This corresponds to the phase gradient equal to the inverse value of the Ginzburg-Landau coherence length according to Eq.(6)

As was shown in [33] the local gradient energy is equal to the energy of HPD formation. In reality the situation is more complicated. One should take into account the spectroscopic correction to the gradient energy that leads to the frequency shift of precession $\Omega_{\nabla} = \partial F_{\nabla} / \partial P$:

$$\Omega_{\nabla} = \frac{5c_{\parallel}^2 - c_{\perp}^2}{4\omega} \nabla \alpha^2 \quad (9)$$

The value of the dipole-dipole frequency shift decreases with increasing current in order to compensate this gradient energy frequency shift and to keep the HPD in the channel in resonance. But when Ω_{∇} surpasses the difference between the HPD frequency and the Larmor frequency in the channel, the HPD can no longer exist and the angle β decreases. Therefore the density of P , pro-

portional to $(1 - \cos \beta)$, decreases which makes the spin current solution unstable. Interestingly an analogous instability takes place in the case of mass supercurrent in $^3\text{He-B}$ due to Fermi liquid corrections. As was shown in [34], the superfluid density in $^3\text{He-B}$ decreases with increasing gradient of phase of the wave function (velocity). Consequently the critical supercurrent corresponds to a maximum value of current as a function of this gradient. By taking into account the circumstances given above, the critical spin supercurrent should correspond to the gradient:

$$\nabla \alpha_c = \sqrt{\frac{4\omega_L(\omega_{RF} - \omega_L)}{5c_{\parallel}^2 - c_{\perp}^2}} \quad (10)$$

In Fig. 4 we show the experimental value of the critical phase difference between two HPD as function of $\omega_{RF} - \omega_L$. In order to compare these results with theory one should take into account the distribution of phase gradient in a channel, given by 8. There is a good agreement with the theory, particularly if we use the spin diffusion coefficient as a fitting parameter, that is $D = 0.035 \text{ cm}^2/\text{s}$. (solid line in Fig. 4). For the D_{\perp} , measured under the same conditions we have $D_{\perp} = 0.058 \text{ cm}^2/\text{s}$. This discrepancy is probably caused by spin - diffusion anisotropy [29, 35], demonstrated experimentally for the first time.

SPIN-CURRENT JOSEPHSON EFFECT

The Josephson effect is the response of the current to the phase between two weakly connected regions of coherent quantum states. It was described by Josephson [36]

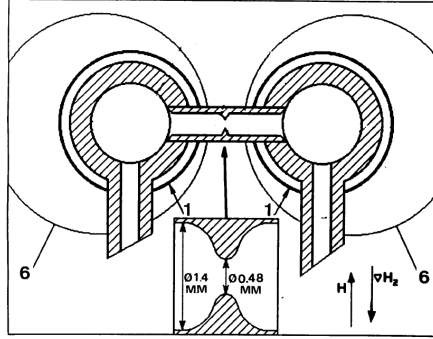

FIG. 5: For observation of the dc and ac Josephson effects the orifice of diameter about 0.48 mm was installed inside the channel.

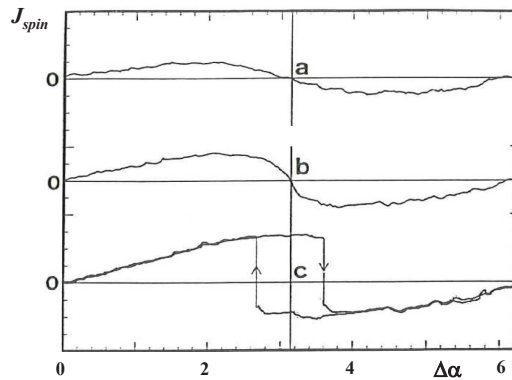

FIG. 6: The Josephson effect for magnon BEC demonstrates the interference between two magnon condensates. Spin current as a function of the phase difference across the junction, $\alpha_2 - \alpha_1$, where α_1 and α_2 are phases of precession in two coherently precessing domains. Different experimental records correspond to a different ratio between the diameter of the orifice and the coherence length ξ of magnon BEC. The pure dc Josephson phenomenon was observed for magnetic coherent length $\xi = 1.3$ mm (a) and the distorted one for $\xi = 0.8$ mm (b). The phase slippage processes were observed for $\xi = 0.7$ mm (c).

for the case of two quantum states, separated by the potential barrier. This phenomenon is usually studied for the case of quantum states connected by a conducting bridge with the dimensions smaller than the coherence length. In this case the coherent state in the bridge cannot be established so there is no phase memory, which determines the direction of the phase gradient. As a result the supercurrent is determined only by the phase difference between the two states. As the dimensions of the conducting bridge increase, the more complex current-phase relation is observed. For bridge dimensions of the

order of the coherence length, a transition to a hysteretic scenario with phase slippage appears.

In the case of mass and electronic supercurrents the coherence length is a function of the temperature. In the case of spin supercurrents, however, the Ginzburg-Landau coherence length ξ is not only a function of temperature, but also a function of the difference between the HPD precession frequency and the local Larmor frequency, according to Eq.(6). This quantity can be varied experimentally with a magnetic field gradient or position of the domain boundary. As a result one is

able to change the coherence length in the region of the orifice in the channel and observe the change from the canonical current-phase relation to phase slip behavior. This experiment made in Kapitza Institute [27, 37, 38] is schematically presented in Fig. 6. The orifice, of diameter 0.48 mm, was placed in the central part of the channel. The current-phase characteristics, observed in this experiment are represented for different positions of the domain boundary related to the orifice. One can easily see that the current in Fig. (a) corresponds to the canonical current-phase relation, which transforms to the nonlinear relation in Fig. (b) and then to a phase slip phenomenon in Fig. (c).

In the insertion the modification of the channel profile and screen for the observation of Josephson phenomena is shown.

The first attempt to describe theoretically the spin supercurrent Josephson phenomenon was made in [39]. In spite of some difficulties in presenting a simple mathematical model of the spin supercurrent in an orifice, his calculations have a qualitative agreement with the observed phenomena.

MAGNON BEC STATES

The formation of magnon BEC states was confirmed by a many observation. First of all it is the observation of Nambu-Goldstone (NG) mode of magnons condensate [17, 18]. This modes are the magnetic analog of second sound in superfluid ^4He . It is very important achievement to support the BEC state permanently. It allow to perform the steady state experiments with a two BECs connected by a channel. The spin supercurrent [40], phase slippage [41], Josephson effect [37, 38], spin vortex[42, 43] and other supermagnonic quantum phenomena was observed.

There was discovered the other types of magnon BEC states in $^3\text{He-B}$; the self-trapped BEC state, named Q-ball [44], the state at a global minimum of dipole-dipole energy, named HPD2 [45] and the state with partial magnetization [46, 47]. The magnon BEC was suggested in superfluid $^3\text{He-A}$ [48] and it was observed by pulse [49] and CW [50, 51] methods. Recently the magnon BEC and spin superfluidity was observed in a new antiferromagnetic superfluid state - $^3\text{He-P}$ [52].

There are no any specific properties of antiferromagnetic superfluid states of ^3He , which give advantage for magnon BEC formation, except the very small Gilbert damping factor of magnons, which can be as low as 10^{-8} . Indeed it should be possible to found magnon BEC phenomena in other solid magnetics, as was predicted in [53]. Particularly it was very interesting to search the magnon BEC in systems with coupled nuclear-electron precession, which properties are very similar to $^3\text{He-A}$ in aerogel [54]. We have successfully found the formation of magnon

BEC in antiferromagnets MnCO_3 and CsMnF_3 at 1.5°K temperature by CW [55] and pulsed [56] NMR. The observation was done on quasinuclear branch of precession, which characterized by Gilbert damping factor of about 10^{-5} and the repulsive interaction between magnons. The new techniques of magnon BEC formation was developed: the non-resonance excitation of magnon BEC [57] and the switch off RF field method [59]. The magnon BEC was observed even in very inhomogeneous conditions [58].

A new breakthrough in research has taken place in YIG. The BEC state of magnons with wave vector $k = 0$ was observed in normally magnetized Yttrium Ferrite Garnet thin film at room temperature [60]. This magnon BEC state differed from observed early magnon BEC state in YIG film magnetized tangentially [61], where magnons with non-zero k were condensed.

ACKNOWLEDGMENTS

The authors wish to thank G. E. Volovik, V. P. Mineev, V. Lvov and O. A. Serga for helpful comments. This work was financially supported by the Russian Science Foundation (grant RSF 16-12-10359).

-
- [1] Kouki Nakata, Pascal Simon & Daniel Loss “Spin Currents and Magnon Dynamics in Insulating Magnets” *J. Phys. D: Appl. Phys.* **50**, 114004 (2017)
 - [2] O. Gomonay, V. Baltz, A. Brataas & Y. Tserkovnyak “Antiferromagnetic spin textures and dynamics” *Nature Physics* **14**(3) DOI: 10.1038/s41567-018-0049-4 (2018).
 - [3] Rezende, S. M., Rodriguez-Surez, R. L. & Azevedo, A. “Diffusive magnonic spin transport in antiferromagnetic insulators” *Phys. Rev. B* **93**, 054412 (2016).
 - [4] Einstein, A. ”Quantentheorie des einatomigen idealen Gases. Part I”. *Sber. Preuss. Akad. Wiss.* **22**, 261267 (1924); ”Quantentheorie des einatomigen idealen Gases. Part II”. *Sber. Preuss. Akad. Wiss.* **1**, 3-14 (1925).
 - [5] Gazizulin, R. R., Bunkov, Yu. M., Safonov, V. L. Critical parameters of nuclear magnon BoseEinstein condensation in systems with dynamical frequency shift *JETP Lett.*, **102**, 876–880, (2015).
 - [6] Bunkov, Yu. M., Safonov, V. L. ”Magnon condensation and spin superfluidity”. *Journal of Magnetism and Magnetic Materials* **452**, 3034 (2018).
 - [7] G.E. Volovik, Linear momentum in ferromagnets, *J. Phys. C* **20**, L83-87 (1987).
 - [8] Bunkov, Yu. M. & Volovik, G. E. “Bose-Einstein Condensation of Magnons in Superfluid ^3He ”. *J. of Low Temp. Phys.* **150**, 135-144 (2008).
 - [9] Borovik-Romanov, A. S., Bunkov, Yu. M., Dmitriev, V. V. & Mukharskii, Yu. M. “Long-lived induction signal in superfluid $^3\text{He-B}$ ”. *JETP Lett.* **40**, 1033-1037 (1984).
 - [10] Fomin, I. A. “Long-lived induction signal and spatially nonuniform spin precession in $^3\text{He-B}$ ”. *JETP Lett.* **40**, 1037-1040 (1984).

- [11] Kagan, Y. & Manakova, L. A. "Condensation of phonons in an ultracold Bose gas". *Phys. Lett. A* **361**, 401 (2007).
- [12] Butov L. V. *et al.* "Stimulated Scattering of Indirect Excitons in Coupled Quantum Wells: Signature of a Degenerate Bose-Gas of Excitons". *Phys. Rev. Lett.* **86**, 5608 (2001).
- [13] Kasprzak, J. *et al.* "Bose-Einstein condensation of exciton polaritons". *Nature (London)* **443**, 409 (2006).
- [14] Klaers, J., Schmitt J., Vewinger, F., & Weitz, M. "Bose-Einstein condensation of photons in an optical microcavity" *Nature (London)* **468**, 545 (2010).
- [15] Melnikovskiy, L. A. "Bose-Einstein condensation of rotons". *Phys. Rev. B* **84**, 024525 (2011).
- [16] Volovik, G. E. "On the broken time translation symmetry in macroscopic systems: Precessing states and off-diagonal long-range order". *JETP Lett.* **98**, 491-495 (2013).
- [17] Bunkov, Yu. M., Dmitriev, V. V. & Mukharskii, Yu. M. "Torsional vibrations of a domain with uniform magnetization precession in $^3\text{He-B}$ ". *JETP Lett.* **43**, 131-134 (1986).
- [18] Bunkov, Yu. M., Dmitriev, V. V. & Mukharskii, Yu. M. "Low frequency oscillations of the homogeneously precessing domain in $^3\text{He-B}$ ". *Physica B* **178**, 196-201 (1992).
- [19] Yu. M. Bunkov, A. V. Klochkov, T. R. Safin K. R. Safiullin, M. S. Tagirov "Goldstone Mode of a Magnon Bose-Einstein Condensate in MnCO_3 " *JETP Lett.*, 106, 677-681 (2017)
- [20] Borovik-Romanov, A. S., Bunkov, Yu. M., Dmitriev, V. V., Mukharskii, Yu. M. & Flachbart, K. "Experimental study of separation of magnetization precession in $^3\text{He-B}$ into two magnetic domains". *JETP* **61**, 1199-1206 (1985).
- [21] Snoke, D. "Coherent questions". *Nature* **443**, 403-404 (2006).
- [22] Bunkov, Yu. M. "Magnon BEC Versus Atomic BEC". *J. Low Temp. Phys.* **185**, 399-408 (2016).
- [23] Borovik-Romanov, A.S. *et al.* "Distinctive Features of a CW NMR in $^3\text{He-B}$ due to a Spin Supercurrent", *JETP* **69**, 542 (1989).
- [24] Bunkov, Yu. M. "Spin superfluidity and coherent spin precession". *J. Phys.: Condens. Matter* **21**, 164201 (2009).
- [25] Bunkov, Yu. M. & Volovik, G. E. "Magnon Bose-Einstein condensation and spin superfluidity". *J. Phys.: Condens. Matter* **22**, 164210 (2010).
- [26] A.S.Borovik-Romanov, Yu.M.Bunkov, V.V.Dmitriev, Yu.M.Mukharskiy and D.A.Sergatskov, Investigation of spin supercurrent in $^3\text{He-B}$, *Phys. Rev. Lett.* **62**, 1631-1634 (1989).
- [27] Yu.M. Bunkov, Spin supercurrent and novel properties of NMR in superfluid ^3He , in: *Prog. Low Temp. Phys.* Vol XIV, p. 69, ed. W. Halperin, Elsevier, Amsterdam (1995).
- [28] Yu.M.Bunkov, V.V.Dmitriev, Yu.M.Mukharskiy and G.K.Tvalashvily, Superfluid spin current in a channel parallel to the magnetic field, *Sov. Phys. JETP* **67**, 300 (1988).
- [29] Einzel, O., 1981, *Physica* 108B, 1143.
- [30] Bunkov, Yu. M. *et al.*, Catastrophic Relaxation in $^3\text{He-B}$ at $0.4 T_c$ *Europhysics Letters*, **8**, 645 (1989).
- [31] Ivlev, B.I. and N.B. Kopnin, 1984, *Sov. Phys. Uspekhy* **27**, 206.
- [32] Varoquaux, E., O. Avenel. G. Ihas and R. Salomelin. 1992, *Physica B* 178, 309.
- [33] Fomin, I.A., 1988, *Sov. Phys. JETP* **67**, 1148.
- [34] Vollhardt D. and Wölfle P. (1990). *The superfluid phases of helium 3*, Taylor and Francis, London.
- [35] Sauls, J. A., Bunkov, Yu. M., Collin, E., Godfrin, H. & Sharma, P. "Magnetization and spin diffusion of liquid ^3He in aerogel". *Phys. Rev. B* **72**, 024507 (2005).
- [36] B.D. Josephson, Possible new effects in superconducting tunnelling, *Phys. Lett.* **1**, 251-253 (1962).
- [37] A.S. Borovik-Romanov, Yu.M. Bunkov, A. de Waard, V.V. Dmitriev, V. Makrotsieva, Yu.M. Mukharskiy, D.A. Sergatskov, Observation of a spin supercurrent analog of the Josephson effect, *JETP Lett.* **47**, 478-482 (1988).
- [38] A.S.Borovik-Romanov, Yu.M.Bunkov, V.V.Dmitriev, Yu.M.Mukharskiy and D.A.Sergatskov, Josephson effect in spin supercurrent in $^3\text{He-B}$, *AIP Conf. Proc.* **194**, 27 (1989).
- [39] A.V. Markelov, Josephson effect on a spin current, *JETP* **67**, 520-523 (1988).
- [40] Borovik-Romanov, A. S., Bunkov, Yu. M., Dmitriev, V. V., Mukharskiy, Yu. M. & Sergatskov, D. A. "Investigation of Spin Supercurrent in $^3\text{He-B}$ ". *Phys. Rev. Lett.* **62**, 1631-1634 (1989).
- [41] Borovik-Romanov, A. S., Bunkov, Yu. M., Dmitriev, V. V. & Mukharskii, Yu. M. "Observation of phase slippage during the flow of a superfluid spin current in $^3\text{He-B}$ ". *JETP Lett.* **45**, 124-128 (1987).
- [42] Borovik-Romanov, A. S. *et al.* "Observation of Vortex-like Spin Supercurrent in $^3\text{He-B}$ ". *Physica B* **165**, 649-650 (1990).
- [43] Bunkov, Yu. M. & Volovik, G. E. "Spin vortex in magnon BEC of superfluid $^3\text{He-B}$ ". *Physica C* **468**, 609-612 (2008).
- [44] Autti, S. *et al.* "Self-Trapping of Magnon Bose-Einstein Condensates in the Ground State and on Excited Levels: From Harmonic to Box Confinement". *Phys. Rev. Lett.* **108**, 145303 (2012).
- [45] Elbs, J. *et al.* "Strong Orientational Effect of Stretched Aerogel on the ^3He Order Parameter". *Phys. Rev. Lett.* **100**, 215304 (2008).
- [46] Dmitriev, V. V. *et al.* "Stable Spin Precession at One Half of Equilibrium Magnetization in Superfluid $^3\text{He-B}$ " *Phys. Rev. Lett.*, **78**, 86-89 (1997).
- [47] Bunkov, Yu. M. *et al.*, Semi-superfluidity of ^3He in Aerogel *Phys. Rev. Lett.* **85**, 3456 (2000).
- [48] Bunkov, Yu. M. & Volovik, G. E. "On the possibility of the Homogeneously Precessing Domain in Bulk $^3\text{He-A}$ ". *Europhys. Lett.* **21**, 837 (1993).
- [49] Hunger, P., Bunkov, Yu. M., Collin, E. & Godfrin, H. "Evidence for Magnon BEC in Superfluid $^3\text{He-A}$ ". *J. of Low Temp. Phys* **158**, 129134 (2010).
- [50] Sato, T. *et al.* "Coherent Precession of Magnetization in the Superfluid ^3He A-Phase". *Phys. Rev. Lett.* **101**, 055301 (2008).
- [51] Matsubara, A. *et al.* Coherent precession of magnetization in superfluid ^3He A-phase in aerogel *J. Phys.: Conf. Ser.* **150** 032052 (2009).
- [52] Autti, S. *et al.* "Bose-Einstein condensation of magnons and spin superfluidity in the polar phase of ^3He " *Phys. Rev. Lett.*, **121**, 025303 (2018).
- [53] Bunkov, Yu.M. "Spin superfluidity and magnons Bose-Einstein condensation" *Physics Uspekhi*, **53**, 848 (2010).
- [54] Bunkov, Yu.M. & Dumesh, B.S. "Dynamic Properties of Pulsed NMR at Easy Plane Antiferromagnets with Large

- Pulling" *Sov. Phys. JETPh* **41**, 576 (1975).
- [55] Bunkov, Yu. M. *et al.* "High- T_c Spin Superfluidity in Antiferromagnets". *Phys. Rev. Lett.* **108**, 177002 (2012).
- [56] Tagirov, M. S. *et al.* "Magnon BEC in Antiferromagnets with Suhl-Nakamura Interaction". *J. Low Temp. Phys.* **175**, 167-176 (2014).
- [57] Bunkov, Yu. M. *et al.* *JETP Lett.* **109**, 43 (2019).
- [58] Bunkov, Yu. M. & Tagirov, M. S. "Magnon Bose-Einstein condensation at inhomogeneous conditions". *Journal of Physics: Conference Series* **478**, 012004 (2013).
- [59] Bunkov, Yu. M. "The magnon BEC observation by switch off method". *Low Temp. Phys* **43**, 1158-1160 (2017).
- [60] Bunkov, Yu. M. *et al.* "Conventional magnon BEC in YIG film" <http://arxiv.org/abs/1810.08051v2> (2018)
- [61] Serga, A. A., Chumak, A. V. & Hillebrands, B. YIG magnonics, *J. Phys. D: Appl. Phys* **43**, 264002 (2010).