

Composable secure multi-client delegated quantum computation

Monireh Houshmand^{1,2}, Mahboobeh Houshmand^{1,2}, Si-Hui Tan^{1,2}, and Joseph F. Fitzsimons^{1,2}

¹Singapore University of Technology and Design, 8 Somapah Road, Singapore 487372,

²Centre for Quantum Technologies, National University of Singapore, Block S15, 3 Science Drive 2, Singapore 117543

Keywords: Delegated quantum computation, Multiple Clients, Composable security, Verification.

Abstract. The engineering challenges involved in building large scale quantum computers, and the associated infrastructure requirements, mean that when such devices become available it is likely that this will be in limited numbers and in limited geographic locations. It is likely that many users will need to rely on remote access to delegate their computation to the available hardware. In such a scenario, the privacy and reliability of the delegated computations are important concerns. On the other hand, the distributed nature of modern computations has led to a widespread class of applications in which a group of parties attempt to perform a joint task over their inputs, e.g., in cloud computing. In this paper, we study the multi-client delegated quantum computation problem where we consider the global computation be made up of local computations that are individually decided by the clients. Each client part is kept secret from the server and the other clients. We construct a composable secure multi-client delegated quantum computation scheme from any composable secure single-client delegated quantum computation protocol and quantum authentication codes.

1 Introduction

The distributed nature of modern computations has led to a widespread class of applications in which a group of parties perform a joint task over their inputs. In these situations, it is very often desirable that the parties' privacy should be preserved due to the fact that they may be mutually distrustful. This has stimulated extensive research in classical cryptography, in the form of secure multi-party computation (MPC) [54,23,46]. The aim of MPC is to guarantee that the joint public task is carried out correctly and that the parties will not obtain any information from their interactions other than the final output of the computation and what is naturally leaked from it. Some applications of MPC include secure decentralized elections, secure auctions and private data mining. Private function evaluation [37,36,4,12] (PFE), is a special case of MPC, where the parties compute a function which is determined privately by one of

the parties. The key additional security requirement is that the only permitted leakage to an adversary about the function is the size of the circuit evaluating it.

There has also been work on quantum extensions of MPC, namely secure multi-party quantum computation (MPQC) [14,8], based on verifiable quantum secret sharing. In [18], the problem of privately evaluating some unitary transformation against the quantum version of classical semihonest adversaries over a joint input state held by two parties was addressed. This study was later made secure against more malicious adversaries in [19].

In the schemes mentioned above, all parties are assumed to have quantum computational power. However, as realising scalable and reliable quantum computers is an important challenge, when they can be built, it is likely that there will be a limited number of them available. In this case, clients with restricted quantum capabilities may need to securely delegate their computations to a universal quantum server, in the sense that their inputs, computation and outputs remain hidden from the server. This is known as blind quantum computation (BQC).

BQC was first considered by Childs [13] using the idea of encrypting the input qubits with a quantum one-time pad [1]. A subsequent research in this field was presented in [3], which was equipped with the possibility of detecting a malicious server. However, these approaches required complex quantum capabilities on the client's side. The complexity of the client's device was reduced in [10] to preparing a certain set of single qubit states, and a universal blind quantum computing (UBQC) protocol was presented. This was the first protocol to take advantage of the measurement-based quantum computation model (MBQC) [50] for BQC. A different approach for utilising MBQC for UBQC was proposed in [43] where the client only makes measurements instead of state preparation. The security of this protocol is based on the no-signaling principle [47]. In recent years, various aspects of BQC have been studied [51,38,41,30,39,17,43,16,31,22,32,44,42,42], and a number of schemes have been successfully implemented in experiment [7,6,24,27].

A deeply coupled property with any BQC is verifiability, which is the ability of the client to verify the correctness of delegated quantum computation (DQC). The verification mechanism allows clients to either confirm that the server has followed the instructions of the protocol, or detect if it has deviated from the protocol. There are basically two main approaches for the verification of BQC in the literature, namely trapped-based and stabilizer testing. The former approach typified by [20] uses hidden traps in the resource state that do not affect the computation. Following that, trap-based techniques have been utilised in [39,21,25]. The second approach [43] only requires the server to generate many-qubit states. Thus, the client only has to verify those states and this goal can be achieved by directly verifying the stabilizers of the states, which is called stabilizer testing [26,40].

However, in the results described above, the security definition under which security of the protocols has been considered was in a stand-alone setting, where

the protocol is studied in isolation from the environment. For instance, in [10] a protocol is said to be blind if the distribution of the classical and the quantum information obtained by the server is fully determined by the permitted leakage. The permitted leakage is what the server can unavoidably learn from the interactions with the client. Most of the BQC protocols proposed so far have used some form of this definition. However, the stand-alone definition of blindness does not provide any guarantee on the behaviour of the protocol when it is used as a subroutine in a larger system. A stronger form of cryptographic security is composable security [11,45,34] which certifies the security of a protocol when run together with many other protocols, even if they are insecure. Specifically, composable security definitions for DQC were introduced in [15]. It has been shown that the UBQC protocols in [20] and [43] satisfy these definitions.

The problem of secure delegation of a multi-party quantum computation to a server having a universal quantum computer is addressed in [29]. In this setting, a number of computationally weak clients (possibly mistrustful) intend to perform a global unitary operation, known to all of them a priori, on their joint input state with the help of a powerful untrusted server. In this approach, the private data of the clients remain secret during the protocol and the computation performed is not known to the server. The security of the protocol against a dishonest server and against dishonest clients, under the assumption of common classical cryptographic constructions, is proved.

In this paper, we examine the multi-client DQC problem from a different perspective. In our setting, we let the global unitary be made up of local unitaries that are individually decided by the clients. All local unitaries of each client are kept secret from the server and the other clients. We construct a composable secure multi-client DQC scheme from any composable secure single-client DQC and quantum authentication codes. Our scheme finds application in, e.g., distributed cloud computing [2], in which clients from multiple geographic locations process their data on a server to perform a global computation.

The paper is organised as follows. In the next section, the needed preliminaries are provided. In Section 3, the proposed protocol for multi-client DQC and the proof of security is presented. The optimisation of the protocol is provided in Section 4 by reducing the quantum communication between the clients and the server. Finally, Section 5 concludes the paper.

2 Preliminaries

2.1 Composable Security

Local security definitions consider cryptographic protocol problems in a model where the only involved parties are the actual participants in the protocol, and only a single execution of the protocol happens. However, this model of stand-alone execution does not fully capture the security requirements of a cryptographic protocol which is embedded in a larger scheme and is run concurrently with a number of other protocols. For a cryptographic protocol to be usable in a larger context, the security definitions need to be composable.

A strong and desirable security definition is given by composable security, using three approaches: the universal composable (UC) framework [11], reactive simulatability (RS) [45] and the abstract cryptography (AC) developed by Maurer and Renner [34]. These security definitions have also been extended to the quantum setting [9,53,49].

In contrast to UC and RS, AC uses a top-down paradigm which first considers a higher level of abstraction, provides definitions and theorems at this level and then proceeds downwards, introducing in each new lower level only the absolutely essential specializations. The fundamental element of AC is a *system*, an abstract object with interfaces through which it interacts with the environment and/or other systems. Systems are composed of three classes, namely resources, converters, and distinguishers. A *resource* is a system with a set of interfaces. Generally, each interface is devoted to one party, representing the functionalities that are accessible to that party. *Converters* are used to transform one resource into another and capture operations that a player might perform locally at their interface. These are systems with only two interfaces, one is designed as an inside interface and the other one as an outside interface. The inside interface is connected to the resources and the outside interface receives inputs and produces outputs. We write either $\pi_i\mathcal{R}$ or $\mathcal{R}\pi_i$ to describe the new resource with the converter π_i connected at the interface i .

A set of converters which describe how available resources are combined to realise another resource is called a *protocol*. Another type of converter that we need is a *filter*. For a cryptographic protocol to be useful, it is not sufficient to provide guarantees on what happens when an adversary is present, one also has to provide a guarantee on what happens when no adversary is present. We model this setting by covering the adversarial interface with a filter that emulates honest behaviour.

The closeness of two resources is defined by a pseudo-metric $d(\cdot, \cdot)$ on the space of resources which is captured by a *distinguisher*. It is a system which having access to all interfaces of one of the two resources, outputs a bit, deciding which resource it is interacting with. The *distinguisher's advantage* is defined as the difference of probability of the correct output when the distinguisher is connected to either of resources. Since the distinguishing advantage is a pseudo-metric, it respects the triangle inequality. For any resources \mathcal{R}, \mathcal{S} , and \mathcal{T} , we have

$$d(\mathcal{R}, \mathcal{S}) \leq d(\mathcal{R}, \mathcal{T}) + d(\mathcal{T}, \mathcal{S}). \quad (1)$$

Distinguishing advantage is non-increasing under composition with any other system. Therefore for any converter α and resources \mathcal{R}, \mathcal{S} and \mathcal{T} ,

$$d(\alpha\mathcal{R}, \alpha\mathcal{S}) \leq d(\mathcal{R}, \mathcal{S}), \quad (2)$$

$$d(\mathcal{R}\mathcal{T}, \mathcal{S}\mathcal{T}) \leq d(\mathcal{R}, \mathcal{S}). \quad (3)$$

Two resources \mathcal{R} and \mathcal{S} are considered ϵ -close which is denoted by $\mathcal{R} \underset{\epsilon}{\approx} \mathcal{S}$ if no distinguisher (in a certain class of distinguishers) has a distinguishing advantage of more than ϵ .

AC views cryptography as a resource theory: a protocol constructs a (strong) resource given some (weak) resources. Due to this constructive aspect of the framework, it is also called *constructive cryptography* in the literature [33,35]. If a protocol π constructs some resource ϵ -close to \mathcal{S} from another resource \mathcal{R} , we write:

$$\mathcal{R} \xrightarrow{\pi, \epsilon} \mathcal{S}. \quad (4)$$

For a cryptographic construction to be usable in any possibly complex manner, the following composable conditions must be held:

$$\mathcal{R} \xrightarrow{\pi, \epsilon} \mathcal{S} \text{ and } \mathcal{S} \xrightarrow{\pi', \epsilon'} \mathcal{T} \Rightarrow \mathcal{R} \xrightarrow{\pi' \circ \pi, \epsilon + \epsilon'} \mathcal{T},$$

$$\mathcal{R} \xrightarrow{\pi, \epsilon} \mathcal{S} \text{ and } \mathcal{S} \xrightarrow{\pi', \epsilon'} \mathcal{S}' \Rightarrow \mathcal{R} \parallel \mathcal{R}' \xrightarrow{\pi | \pi', \epsilon + \epsilon'} \mathcal{S} \parallel \mathcal{S}',$$

where $\mathcal{R} \parallel \mathcal{R}'$ is the resource resulting from parallel composition of \mathcal{R} and \mathcal{R}' , and $\pi' \circ \pi$ and $\pi | \pi'$ are sequential and parallel composition of protocols, respectively.

If two protocols with composable errors ϵ and δ are run jointly (e.g., one is a subroutine of the other), the error of the composed protocol is bounded by the sum of the individual errors, $\epsilon + \delta$. In Eq. (4), the resource \mathcal{R} along with the protocol π are parts of the concrete protocol and \mathcal{S} is the ideal resource we want to construct. Eq. (4) holds if the adversary, with access to the ideal resource, can get anything that she can get in the real world. In other words, both systems have equivalent behaviour in the sense that they behave identically if plugged into any possible environment or application. From the adversary's point of view, anything that could happen in the real world could identically happen in the ideal world. Simulator systems transform the ideal resource into the real world system consisting of the real resource and the protocol. Now we define the security of a protocol in the three-party setting with honest Alice and Bob and dishonest Eve. See [34] for the general case.

Definition 1. (*Composable security [34]*) Let $\mathcal{R}_\phi = (\mathcal{R}, \phi)$ and $\mathcal{S}_\psi = (\mathcal{S}, \psi)$ be pairs of a resource (\mathcal{R} and \mathcal{S}) with interfaces $\mathcal{I} = \{A, B, E\}$ and filters ϕ and ψ . We say that a protocol $\pi = (\pi_A, \pi_B)$ securely constructs \mathcal{S}_ψ out of \mathcal{R}_ϕ within ϵ and write

$$\mathcal{R}_\phi \xrightarrow{\pi, \epsilon} \mathcal{S}_\psi, \quad (5)$$

if the two following conditions hold:

- $d(\pi \mathcal{R}_\phi, \mathcal{S}_\psi) \leq \epsilon$, and
- there exists a converter σ_E , called a simulator, such that $d(\pi \mathcal{R}, \mathcal{S} \sigma_E) \leq \epsilon$.

2.2 Delegated Quantum Computation

In a two-party DQC, a client evaluates some (quantum) computation using the help of a powerful server. The protocol must guarantee blindness, capturing the idea that the server learns nothing about the input, the output, and the computation the client evaluated other than what is unavoidable (computation

size, etc.). The other security concern is verifiability, which indicates that the client can verify whether the server has followed the instructions or has deviated from them.

The composable security of DQC using the aforementioned AC framework was presented in [15]. Having introduced the notions required in the security definition, the description of the blind verifiable ideal resource model, denoted by \mathcal{S}^{bv} , is presented as follows:

Definition 2. *The ideal DQC resource \mathcal{S}^{bv} which provides correctness, blindness and verifiability, has two interfaces, C and S , standing for the client and the server respectively. It takes ψ_c , representing the description of the client's computation U and quantum input ρ_c at the C interface and a filtered controlled bit f^{bv} at the S interface. If the server sets $f^{\text{bv}} = 0$, \mathcal{S}^{bv} produces the honest result $U\rho_c$ at the C interface. If $f^{\text{bv}} = 1$, the resource outputs the allowed leakage ℓ^{bv} at the S interface and some fixed error state $|\text{err}\rangle\langle\text{err}|$ orthogonal to the output space at the C interface.*

Now we model the structure of a generic two-party DQC protocol, $\pi^{\text{bv}} = (\pi_c^{\text{bv}}, \pi_s^{\text{bv}})$. The only resource that parties require is a two-way communication channel \mathcal{R} . Client's protocol π_c receives ψ_c (including the description of ρ_c and U) as input on its outside interface. It then communicates with the server's protocol π_s via \mathcal{R} and produces some final output τ_c . Any such process where client's system is denoted C and the server's system S , is modelled as a sequence of CPTP maps $\{\mathcal{E}_i : \mathcal{L}(\mathcal{H}_{C\mathcal{R}}) \rightarrow \mathcal{L}(\mathcal{H}_{C\mathcal{R}})\}_{i=1}^N$ and $\{\mathcal{F}_i : \mathcal{L}(\mathcal{H}_{\mathcal{R}S}) \rightarrow \mathcal{L}(\mathcal{H}_{\mathcal{R}S})\}_{i=1}^{N-1}$ which client and the server apply sequentially to their respective systems and the communication channel \mathcal{R} . The protocol $\pi^{\text{bv}} = (\pi_c^{\text{bv}}, \pi_s^{\text{bv}})$ is a map which, using the channel \mathcal{R} , transforms ψ_c into τ_c . If both players play honestly and the protocol is correct this should result in $\tau_c = U\rho_c$.

Definition 3. *A DQC protocol $\pi^{\text{bv}} = (\pi_c^{\text{bv}}, \pi_s^{\text{bv}})$ constructs a blind verifiable resource \mathcal{S}^{bv} from the communication channel \mathcal{R} within ϵ^{bv} if the two following conditions are satisfied:*

$$\pi_c^{\text{bv}} \mathcal{R} \pi_s^{\text{bv}} \underset{\epsilon^{\text{bv}}}{\approx} \mathcal{S}^{\text{bv}} \perp_s, \quad (6)$$

$$\pi_c^{\text{bv}} \mathcal{R} \underset{\epsilon^{\text{bv}}}{\approx} \mathcal{S}^{\text{bv}} \sigma_s^{\text{bv}}, \quad (7)$$

where \perp_s is a protocol which just sets the filtered bit f^{bv} to zero, and σ_s^{bv} is some simulator.

If the first equation is satisfied, the protocol provides ϵ^{bv} -composable-correctness with respect to the ideal resource, \mathcal{S}^{bv} . Correctness captures the notion that the input-output behaviour of the proposed protocol actually matches the input-output behaviour of the ideal resource when the server is behaving honestly. The second condition guarantees both blindness and verifiability and if it is satisfied we say that we have ϵ^{bv} -blind-verifiability. The simulator is a protocol which, from an outside point of view, makes the ideal protocol look like the real one, accessing only to the interface of the server. A distinguisher which interacts

with $\pi_c^{\text{bv}}\mathcal{R}$ and $\mathcal{S}^{\text{bv}}\sigma_s^{\text{bv}}$ cannot distinguish them within ϵ^{bv} . The server's part of the protocol π_s^{bv} does not appear on the left-hand side of Eq. (7), which indicates that we no longer specify what the server may do. This signifies that blindness and verifiability hold for all possible cheating actions of the server. In the rest of the paper, whenever we refer to BV-DQC(ρ, U), we mean a generic DQC which satisfies the conditions in Eqs. (6) and (7) where ρ and U are the client's inputs.

2.3 Quantum Authentication Codes

A quantum authentication scheme (QAS) consists of procedures for encoding and decoding quantum information which allows for the detection of tampering on the encoded quantum data with a high probability. Quantum authentication codes were first introduced by Barnum *et al* [5]. They also proved that quantum authentication necessarily encrypts the message as well. It therefore follows that any authentication protocol for an m -qubit message requires a $2m$ -bit secret key k to encrypt the message. The security of quantum authentication codes is analysed in [48] in the AC framework. It is proved that the authentication protocols of [5] can construct a secure quantum channel.

Definition 4. *The secure quantum channel $\mathcal{C}^{\text{q-sec}}$ (which provides both authenticity and confidentiality), shown in the top of Figure 1 (a), allows a quantum message ρ to be transmitted from Alice to Bob. The resource only allows Eve to input a filtered control bit $f^{\text{q-sec}}$ that decides if Bob receives the message ($f^{\text{q-sec}} = 0$) or $|\text{err}\rangle\langle\text{err}|$ ($f^{\text{q-sec}} = 1$). It only leaks $\ell^{\text{q-sec}}$ to the adversary, denoted by the dashed arrow in Figure 1 (a), which is a notification that the message has been sent as well as its length.*

The required resources in the concrete setting of QAS are a *quantum insecure channel* $\mathcal{C}^{\text{q-insec}}$ and a *secret key resource* \mathcal{K} . $\mathcal{C}^{\text{q-insec}}$ is completely under the control of the adversary. It allows the adversary to intercept the message sent from the sender to the receiver and replace it with any message of their choosing at their interface. \mathcal{K} has three interfaces A , B and E . It outputs a perfectly uniform secret key k at the interfaces A and B and it has no functionality at the adversary's interface E . The QAS protocol which includes the pair of converters (π_A^e, π_B^d) constructs $\mathcal{C}^{\text{q-sec}}$ given $\mathcal{C}^{\text{q-insec}}$ and \mathcal{K} within error $\epsilon^{\text{q-sec}}$, if the following equation is satisfied:

$$\pi_A^e \pi_B^d (\mathcal{K} || \mathcal{C}^{\text{q-insec}}) \underset{\epsilon^{\text{q-sec}}}{\approx} \mathcal{C}^{\text{q-sec}} \sigma_E^{\text{q-sec}}, \quad (8)$$

where π_A^e is a converter which receives input state ρ at its outside interface. It requests a key k from \mathcal{K} , applies a map E_k on ρ which outputs an authenticated state τ and sends it through $\mathcal{C}^{\text{q-insec}}$. π_B^d takes in a (possibly) tampered state τ' and applies a verification map D_k and outputs the state ρ' . ρ' is equal to ρ if the verification succeeds and is equal to $|\text{err}\rangle\langle\text{err}|$ otherwise (Figure 1 (b)). The converter $\sigma_E^{\text{q-sec}}$ (shown in Figure 1 (a)) is a simulator that given access only to the E interface of $\mathcal{C}^{\text{q-sec}}$ is able to emulate the behaviour of the adversary so that the real-world protocol (involving the adversary) is statistically indistinguishable from the ideal-world protocol (involving the simulator).

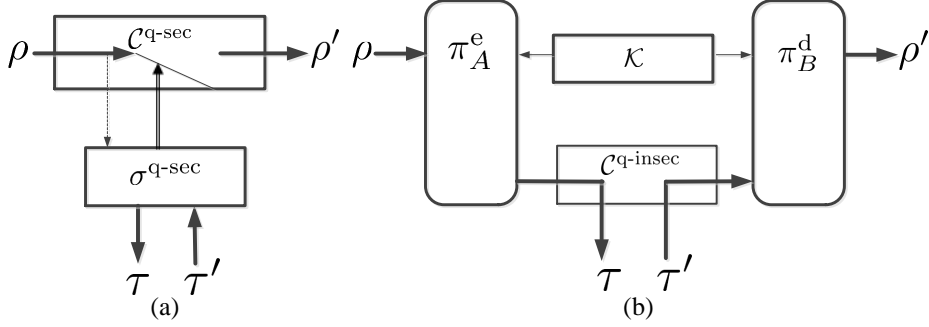

Fig. 1. a). A schematic of the ideal resource (top) and simulator (bottom) for a secure quantum channel. Alice, Bob and Eve have access to the left, right and bottom interfaces of ideal resource $\mathcal{C}^{\text{q-sec}}$, respectively. A simulator $\sigma_E^{\text{q-sec}}$ can be appended to Eve's interface so that the interfaces of the compound object matches those of concrete protocol in (b). b) The QAS protocol (π_A^e, π_B^d) constructs $\mathcal{C}^{\text{q-sec}}$ given $\mathcal{C}^{\text{q-insec}}$ and \mathcal{K} .

3 Multi-Client Delegated Quantum Computation

In this section, we present definitions for multi-client DQC. In this scheme, n clients, $\text{Client}_1, \text{Client}_2, \dots$, and Client_n delegate a global computation to an untrusted powerful server in a blind verifiable manner. Client_i is responsible for providing their own part of the input state ρ_i . The global computation is comprised of a network of local unitaries, individually defined by each client. The clients' computations may interlock in the sense that their local unitaries may affect qubits that are (part of) the outputs of other clients' local unitaries. We call these qubits, *common* qubits. The output of the global computation is split into n components such that every Client_i receives one part ρ_i . In addition to security concerns on the server side, the privacy among the clients is required. Each client learns no information about the input, local unitaries and output states of the other clients apart from what can be learned by their input, their local unitary outputs, and the final output state.

The multiple clients may interact in many configurations which are proven to be universal, such as nearest neighbour topology, where each client interacts only with their nearest neighbours. However, a desired topology for a multi-client DQC should be i) a regular arrangement which can hide the structure of the protocol such that all that is revealed is the total size of unitaries defined by clients in each round and ii) no dishonest client can become a communication bottleneck, such that the client can block another client from communicating with the others. We consider a fully connected topology [52] which fulfils these requirements. A fully connected network is a communication network in which each client is connected to all other ones and is represented by a complete graph in graph theory. A fully connected network is symmetric, in the sense that there

is no distinguished node, i.e., every party's view of the rest of the network is the same.

Let us define the set of m local unitaries for Client_i as $\mathcal{U}_i = \{U_i^{(h)}\}_{h \in \{1, \dots, m\}}$, where $U_i^{(h)}$ is the h^{th} local unitary associated with C_i . If the number of local unitaries of the clients is not the same, then identities are appended to make them equal. Figure 2 shows an example of such a setting, with $n = 3$ and $m = 2$. The set of labels of qubits of $U_i^{(h)}$ that are fed into $U_j^{(h+1)}$ is denoted by $T_{i \rightarrow j}^{(h)}$. Now we are ready to define the ideal multi-client DQC resource. In the definition, $\psi_i, i \in \{1, \dots, n\}$ describes the quantum input ρ_i , the set of local unitaries \mathcal{U}_i and the sets $T_{i \rightarrow j}^{(h)}$, where $j \in \{1, \dots, n\}$, and $h \in \{1, \dots, m - 1\}$.

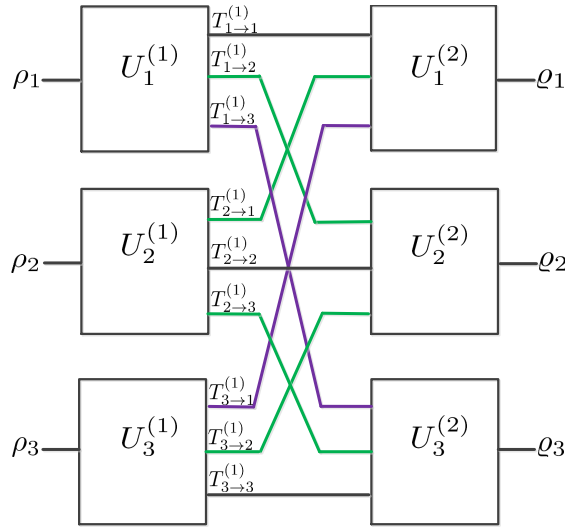

Fig. 2. An example of multi-party computation framework with $n = 3$ and $m = 2$

Definition 5. *The ideal DQC resource with n clients, $\text{Client}_1, \text{Client}_2, \dots, \text{Client}_n$, which provides correctness, blindness, verifiability and privacy among clients is denoted by $\mathcal{S}^{n\text{-bv}}$. $\mathcal{S}^{n\text{-bv}}$ has $n + 1$ interfaces, C_1, \dots, C_n and S standing for $\text{Client}_1, \dots, \text{Client}_n$ and the server respectively. It takes ψ_i at C_i 's interface. The server's interface has a filter controlled bit $f_s^{n\text{-bv}}$. If the server sets $f_s^{n\text{-bv}} = 0$, $\mathcal{S}^{n\text{-bv}}$ produces the correct output result of each client at its interface. If $f_s^{n\text{-bv}} = 1$, $\mathcal{S}^{n\text{-bv}}$ outputs the allowed leakage $\ell^{n\text{-bv}}$ at the server's interface and some fixed error state $|\text{err}\rangle\langle\text{err}|$ that is orthogonal to the output space, at every client's interface (C_1, \dots , and C_n) for which an output is expected.*

After defining the ideal resource that a generic multi-client DQC protocol is expected to construct, we mention the resources that are required to achieve

this, namely, a secret key resource \mathcal{K} , a two-way (quantum and classical) channel \mathcal{R}_i between the server and each Client_i , and an authenticated classical channel $\mathcal{C}^{\text{c-auth}}$ between any pair of clients. $\mathcal{C}^{\text{c-auth}}$ is a channel which allows a classical message to be transmitted from the sender to the receiver. We denote all of the classical authentication channels among clients as $\mathcal{C}_a^{\text{c-auth}}$.

A protocol $\pi^{n\text{-bv}} = (\pi_{c_1}^{n\text{-bv}}, \dots, \pi_{c_n}^{n\text{-bv}}, \pi_s^{n\text{-bv}})$ constructs a blind verifiable resource $\mathcal{S}^{n\text{-bv}}$ from $(\mathcal{K} || \mathcal{C}_a^{\text{c-auth}} || \mathcal{R}_1 || \dots || \mathcal{R}_n)$ within $\epsilon^{n\text{-bv}}$, if the following conditions are satisfied:

$$\begin{aligned} - \pi_{c_1}^{n\text{-bv}} \dots \pi_{c_n}^{n\text{-bv}} \pi_s^{n\text{-bv}} (\mathcal{K} || \mathcal{C}_a^{\text{c-auth}} || \mathcal{R}_1 || \dots || \mathcal{R}_n) &\approx_{\epsilon^{n\text{-bv}}} \mathcal{S}^{n\text{-bv}} \perp_s, \\ - \pi_{c_1}^{n\text{-bv}} \dots \pi_{c_n}^{n\text{-bv}} (\mathcal{K} || \mathcal{C}_a^{\text{c-auth}} || \mathcal{R}_1 || \dots || \mathcal{R}_n) &\approx_{\epsilon^{n\text{-bv}}} \mathcal{S}^{n\text{-bv}} \sigma_s^{n\text{-bv}}. \end{aligned}$$

This ensures security against a dishonest server, and is what we shall focus on proving. A stronger security definition which also captures cheating clients is obtained by replacing the second criterion above with

$$- \pi_{c_{h_1}}^{n\text{-bv}} \dots \pi_{c_{h_H}}^{n\text{-bv}} (\mathcal{K} || \mathcal{C}_a^{\text{c-auth}} || \mathcal{R}_1 || \dots || \mathcal{R}_n) \approx_{\epsilon^{n\text{-bv}}} \mathcal{S}^{n\text{-bv}} \sigma_D^{n\text{-bv}},$$

where the simulator $\sigma_D^{n\text{-bv}}$ acts on the interfaces of all parties except $C_{h_1}, \dots, C_{h_{H-1}}$ and C_{h_H} . A full exploration of protocols for this later model of security is beyond the scope of the current work.

We build the concrete protocol out of subprotocols that already exist. More specifically, the subprotocols consist of any BV-DQC and QAS, without making reference to any particular protocol. Then we use the existing results on the composable security of BV-DQC and QAS to argue that the composition we describe is secure. In terms of these subprotocols, the outline of the concrete setting is as follows. Each client delegates the computation of each local unitary to the server using BV-DQC. If any client detects a verification error, they broadcast $e = 1$ via $\mathcal{C}_a^{\text{c-auth}}$ to all other clients, they all output $|\text{err}\rangle\langle\text{err}|$ and abort the protocol. Otherwise, the client sends the common qubits to the server, and the server sends each qubit to the corresponding clients. The mentioned channel between the server and the client is insecure because the server might tamper the qubits and therefore, the client must protect the qubits with quantum authentication codes.

At the beginning of the protocol, each client agrees on a key for each set of common qubits with the desired recipient. For the first layer of unitaries, true computation followed by an authentication map is delegated to the server. In the intermediate layers, the qubits are first decoded, the true computation is applied, and finally the qubits are encoded again. As for the last layer of local unitary, the qubits are first decoded and then the true computation is applied. All of the aforementioned encoding and decoding maps are carried out by the agreed corresponding keys and as a part of computation. Similar to the case of verification error, if any client detects an authentication error between rounds, they broadcast $e = 1$ via $\mathcal{C}_a^{\text{c-auth}}$ to other clients, they output $|\text{err}\rangle\langle\text{err}|$ and abort the protocol.

A generic protocol for secure multi-client DQC is described in Protocol 1. We note that in order to be secure against dishonest clients, the protocol would need

to be ammended so that any client receiving $e=1$ should immediately rebroadcast this to all other clients before aborting the protocol to avoid a situation where a malicious client could cause only a subset of honest clients to abort.

3.1 Security Proof

Theorem 1. *Protocol 1 constructs $\mathcal{S}^{n\text{-bv}}$ using resources \mathcal{K} , \mathcal{R}_1 , \mathcal{R}_2 and $\mathcal{C}_a^{c\text{-auth}}$, with error $\epsilon^{n\text{-bv}} = (mn)\epsilon^{\text{bv}} + n(n-1)(m-1)\epsilon^{\text{q-sec}}$, where n and m are the numbers of clients and each client's unitaries respectively.*

Proof. We will prove the security for a simple example with two clients, Client₁ and Client₂ each with one local unitary, U_{c_1} and U_{c_2} as shown in Figure 3. The proof can be directly extended for the general case with multiple clients. The definition of the ideal resource related to the example in Figure 6 is as follows. It should be noted that for simplicity we will write $U\rho$ instead of $U\rho U^\dagger$ each time we talk about applying a unitary operation U to a quantum state ρ .

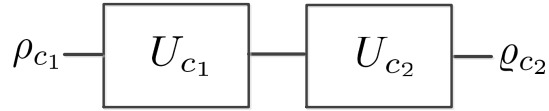

Fig. 3. A sample setting for multi-party computation with two clients, each with one local unitary.

Definition 6. *The ideal 2-client DQC resource related to the example in Figure 3, $\mathcal{S}^{2\text{-bv}}$, which provides correctness, blindness, verifiability and privacy among clients has 3 interfaces, C_1 , C_2 and S standing for Client₁, Client₂ and the server. It takes inputs ρ_{c_1} and U_{c_1} at the C_1 interface, and U_{c_2} at the C_2 interface. The server's interface has a filter controlled bit $f_s^{2\text{-bv}}$. If the server sets $f_s^{2\text{-bv}} = 0$, $\mathcal{S}^{2\text{-bv}}$ outputs $\rho_{c_2} = U_{c_2}U_{c_1}\rho_{c_1}$ at the C_2 interface. If $f_s^{2\text{-bv}} = 1$, the server's interface outputs the allowed leakage and some fixed error state $|\text{err}\rangle \langle \text{err}|$ at the C_2 interface.*

The top of Figure 4 shows the ideal resource $\mathcal{S}^{2\text{-bv}}$. We show that Protocol 2 constructs $\mathcal{S}^{2\text{-bv}}$ using a parallel composition of \mathcal{K} , \mathcal{R}_1 , \mathcal{R}_2 and $\mathcal{C}^{c\text{-auth}}$, with error $\epsilon^{2\text{-bv}} = \epsilon^{\text{q-sec}} + 2\epsilon^{\text{bv}}$. The proof of security proceeds in three main steps. In the first step, it is supposed that the parties have access to quantum capabilities, and hence they do not need the server. In the next step, we move towards the real setting by assuming that the parties do not have quantum capabilities, but delegate the computations to an ideal resource without any error. Finally in the last step, we reach to the real case where the ideal resource may produce error instead of the correct output.

Protocol 1 Blind Verifiable Multi-Client DQC

- 1: Let n and m be the number of clients and the total number of local unitaries of each client respectively.
- 2: Let $i, j \in \{1, \dots, n\}$, $h \in \{1, \dots, m\}$, and $h' \in \{1, \dots, m-1\}$.
- 3: Let $\rho_i, \mathcal{U}_i = \{U_i^{(h)}\}$, and $\varrho_i^{(m)}$ be the input, the set of local unitaries and the output of Client $_i$, respectively.
- 4: Let $T_{i \rightarrow j}^{(h')}$ be the set of labels of output qubits of $U_i^{(h')}$ that are fed into $U_j^{(h'+1)}$.
- 5: Let (E_k, D_k) be a pair of keyed operations to be used to authenticate quantum states.
- 6: Client $_i$ and Client $_j$ ($i \neq j$) agree on a secret key $k_{i \rightarrow j}^{(h')}$ for authenticating the qubits with labels in $T_{i \rightarrow j}^{(h')}$.
- 7: Let

$$V_i^{(h)} = \begin{cases} \otimes_j E_{k_{i \rightarrow j}^{(h)}} U_i^{(h)}, & \text{if } h = 1, \\ \otimes_j E_{k_{i \rightarrow j}^{(h)}} U_i^{(h)} \otimes_j D_{k_{j \rightarrow i}^{(h-1)}}, & \text{if } 1 < h < m, \\ U_i^{(h)} \otimes_j D_{k_{j \rightarrow i}^{(h-1)}}, & \text{if } h = m, \end{cases}$$

where $E_{k_{i \rightarrow j}^{(h)}}$ and $D_{k_{j \rightarrow i}^{(h)}}$ are applied to the qubits with labels in $T_{i \rightarrow j}^{(h)}$.

- 8: **for** $h' := 1$ to $m-1$ **do**
 - 9: **for** $i := 1$ to n **do**
 - 10: Client $_i$ and the server run BV-DQC($\rho_i^{(h')}, V_i^{(h')}$) which outputs $\varrho_i^{(h')}$.
 - 11: **if** $\varrho_i^{(h')}$ is $|\text{err}\rangle\langle\text{err}|$ **then**
 - 12: Client $_i$ sends $e = 1$ to the other clients through an authenticated classical channel and all clients output $|\text{err}\rangle\langle\text{err}|$ and abort the protocol
 - 13: **else**
 - 14: Client $_i$ sends $\varrho_i^{(h')}$ excluding the qubits with labels in $T_{i \rightarrow i}^{(h')}$ to the server
 - 15: **end if**
 - 16: **for** $j := 1$ to n , $j \neq i$ **do**
 - 17: Let $\varrho_{i \rightarrow j}^{(h')}$ be the state of the qubits of $\varrho_i^{(h')}$ in $T_{i \rightarrow j}^{(h')}$
 - 18: The server sends $\varrho_{i \rightarrow j}^{(h')}$ to Client $_j$
 - 19: **end for**
 - 20: **end for**
 - 21: **for** $i := 1$ to n **do**
 - 22: Let $\rho_i^{(h'+1)} = \otimes_j \varrho_{j \rightarrow i}^{(h')}$.
 - 23: **end for**
 - 24: **end for**
 - 25: **for** $i := 1$ to n **do**
 - 26: Client $_i$ and the server run BV-DQC($\rho_i^{(m)}, V_i^{(m)}$) which outputs $\varrho_i^{(m)}$
 - 27: **if** $\varrho_i^{(m)}$ is $|\text{err}\rangle\langle\text{err}|$ **then**
 - 28: Client $_i$ sends $e = 1$ to the other clients through an authenticated classical channel and all clients output $|\text{err}\rangle\langle\text{err}|$ and abort the protocol
 - 29: **else**
 - 30: Client $_i$ outputs $\varrho_i^{(m)}$
 - 31: **end if**
 - 32: **end for**
-

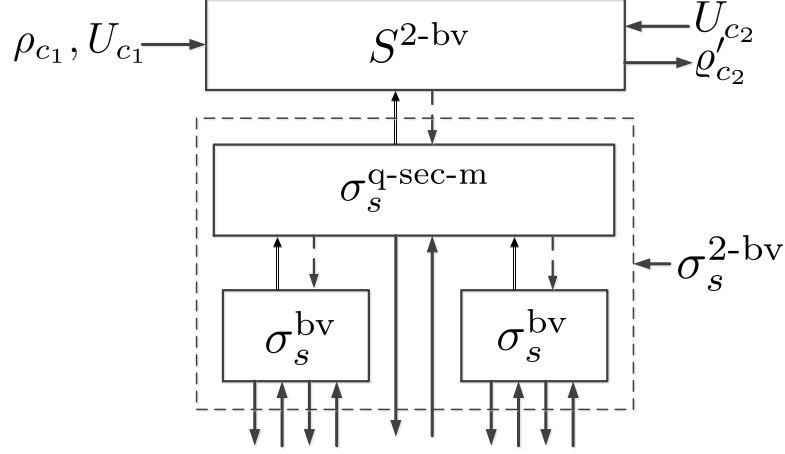

Fig. 4. The top of the figure and the region within the dashed box indicate ideal resource S^{2-bv} and the simulator σ_s^{2-bv} , respectively.

Protocol 2 Blind Verifiable Two-Client DQC for the Setting in Figure 3

- 1: Let ρ_{c_i} and U_{c_i} be the input and local unitary of C_i , respectively, where $i \in \{1, 2\}$.
 - 2: Client₁ and Client₂ agree on a secret key k .
 - 3: Let (E_k, D_k) be a pair of operations for authentication.
 - 4: Client₁ and the server run BV-DQC($\rho_{c_1}, E_k U_{c_1}$) which outputs $\rho_1^{(1)}$.
 - 5: **if** ρ_{c_1} is $|\text{err}\rangle\langle\text{err}|$ **then**
 - 6: Client₁ sends $e = 1$ to the other client through an authenticated classical channel and Client₂ outputs $|\text{err}\rangle\langle\text{err}|$ and aborts the protocol
 - 7: **else**
 - 8: Client₁ sends $\rho_1^{(1)}$ to the server
 - 9: **end if**
 - 10: The server sends $\rho_1^{(1)}$ to Client₂
 - 11: Client₂ and the server run BV-DQC($\rho_1^{(1)}, U_{c_2} D_k$) which outputs ρ'_{c_2}
 - 12: Client₂ outputs ρ'_{c_2}
-

1) First we suppose that the parties have access to quantum capabilities and describe the concrete protocol (shown in Figure 5). In this figure, $\pi_{c_1}^{u_1}$ is a converter which receives the input state ρ_{c_1} , the unitary U_{c_1} , and produces $U_{c_1}\rho_{c_1}$. The converter $\pi_{c_1}^e$ receives $U_{c_1}\rho_{c_1}$ at its inside interface. It requests a key k from \mathcal{K} . It applies E_k to $U_{c_1}\rho_{c_1}$ which outputs an authenticated state τ and sends it through $\mathcal{C}^{q-insec}$. The converter $\pi_{c_2}^d$, takes a (possibly) tampered state τ' on the insecure channel and applies verification D_k . It outputs a state ρ' , which is equal to $U_{c_1}\rho_{c_1}$ or $|\text{err}\rangle\langle\text{err}|$ depending on whether the verification succeeded or failed, respectively. The converter $\pi_{c_2}^{u_2}$ receives ρ' at its inside interface and U_{c_2} at its outside interface and outputs ρ'_{c_2} . If ρ' is $|\text{err}\rangle\langle\text{err}|$, ρ'_{c_2} is equal to

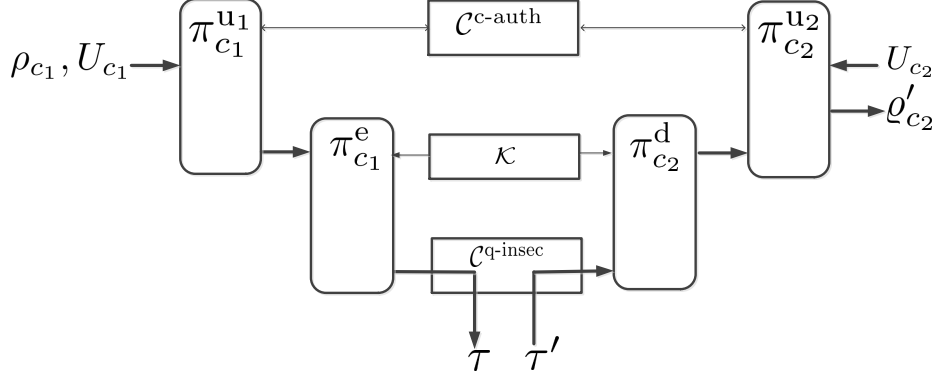

Fig. 5. The concrete protocol for implementing the sample example in Figure 3, where the parties are supposed to have access to quantum capabilities

$|\text{err}\rangle\langle\text{err}|$, otherwise it is $U_{c_2}U_{c_1}\rho_{c_1}$. Using Eq. (8), we have:

$$\pi_{c_1}^{u_1} \pi_{c_2}^{u_2} \pi_{c_1}^e \pi_{c_2}^d (\mathcal{K} || \mathcal{C}^{q-insec}) \underset{\epsilon_{q-sec}}{\approx} \pi_{c_1}^{u_1} \pi_{c_2}^{u_2} \mathcal{C}^{q-sec} \sigma_s^{q-sec}. \quad (9)$$

Eq. (9) holds because based on Eq. (2), adding converters $\pi_{c_1}^{u_1}$ and $\pi_{c_2}^{u_2}$ can only decrease the distance between the two systems. Also we have:

$$\pi_{c_1}^{u_1} \pi_{c_2}^{u_2} \mathcal{C}^{q-sec} \sigma_s^{q-sec} = \mathcal{S}' \sigma_s^{q-sec}, \quad (10)$$

where the ideal resource, \mathcal{S}' is identical to \mathcal{C}^{q-sec} , except that $\pi_{c_1}^{u_1}$ and $\pi_{c_2}^{u_2}$ have been merged with it.

2) In Figure 5, the quantum computations performed by the parties are modelled as converters. We move forward to the real case where the parties do not have access to quantum capabilities. If they want to delegate this to a server it should be modelled as a resource. Now we suppose the clients have access to two resources, \mathcal{S}_1^Q and \mathcal{S}_2^Q which perform the quantum part of the computation, without any error. So we have:

$$\pi_{c_1}^{e'} \pi_{c_2}^{d'} (\mathcal{K} || \mathcal{C}^{q-insec} || \mathcal{S}_1^Q || \mathcal{S}_2^Q) = \pi_{c_1}^{u_1} \pi_{c_2}^{u_2} \pi_{c_1}^e \pi_{c_2}^d (\mathcal{K} || \mathcal{C}^{q-insec}), \quad (11)$$

where $\pi_{c_1}^{e'}$ and $\pi_{c_2}^{d'}$ are now the classical (or almost classical) converters of Client₁ and Client₂ that capture their local operations: $\pi_{c_1}^{e'}$ receives an input state ρ_{c_1} and U_{c_1} at its outer interface, requests a key k and sends ρ_{c_1} and $E_k U_{c_1}$ to \mathcal{S}_1^Q . It receives the response τ and sends it to $\pi_{c_2}^{d'}$ via an insecure channel $\mathcal{C}^{q-insec}$. $\pi_{c_2}^{d'}$ receives τ' on the insecure channel and U_{c_2} at its outer interface, requests the key k from \mathcal{K} , sends τ' and $U_2 D_k$ to \mathcal{S}_2^Q , and receives a response ρ'_{c_2} , which it outputs at its outer interface. ρ'_{c_2} is equal to $|\text{err}\rangle\langle\text{err}|$ if the state has been tampered on the $\mathcal{C}^{q-insec}$, otherwise it is equal to $U_{c_2}U_{c_1}\rho_{c_1}$. Combining Eqs.(9),

(10) and (11) we get:

$$\pi_{c_1}^{e'} \pi_{c_2}^{d'} (\mathcal{K} \| \mathcal{C}^{\text{q-insec}} \| \mathcal{C}^{\text{c-auth}} \| \mathcal{S}_1^{\mathcal{Q}} \| \mathcal{S}_2^{\mathcal{Q}}) \underset{\epsilon^{\text{q-sec}}}{\approx} \mathcal{S}' \sigma_s^{\text{q-sec}}. \quad (12)$$

3) The problem we have now is that $\mathcal{S}_1^{\mathcal{Q}}$ and $\mathcal{S}_2^{\mathcal{Q}}$ are not the ideal resources \mathcal{S}^{bv} constructed by a BV-DQC protocol, because an error might occur during the computation. So $\mathcal{S}_1^{\mathcal{Q}}$ and $\mathcal{S}_2^{\mathcal{Q}}$ should be modified by giving the server the power to flip a switch and produce an error instead of the correct outcome. Now we have \mathcal{S}^{bv} . Also, we need to modify $\pi_{c_1}^{e'}$ because now Client₁ could receive an error from $\mathcal{S}_1^{\text{bv}}$. So the new converter $\pi_{c_1}^{e''}$ behaves identically to $\pi_{c_1}^{e'}$, except when it gets an error from $\mathcal{S}_1^{\text{bv}}$, it sends $e = 1$ to the other client. Also $\pi_{c_1}^{d''}$ is the same as $\pi_{c_1}^{d'}$ but when it receives $e = 1$, it outputs $|\text{err}\rangle\langle\text{err}|$.

We also change the ideal resource \mathcal{S}' slightly. $\mathcal{S}^{2\text{-bv}}$ is identical to \mathcal{S}' , the only difference is that it also leaks ℓ_1^{bv} and ℓ_2^{bv} , and whenever there is an error in computation it outputs $|\text{err}\rangle\langle\text{err}|$ at the C_2 interface. We also have to modify the simulator $\sigma_s^{\text{q-sec}}$ as follows: $\sigma_s^{\text{q-sec-m}}$ behaves the same as $\sigma_s^{\text{q-sec}}$, but it also outputs the leak of both computations ℓ_1^{bv} and ℓ_2^{bv} , and waits for the server to announce if it does the correct computation or not. If so, $\sigma_s^{\text{q-sec-m}}$ tells $\mathcal{S}^{2\text{-bv}}$ to output the correct value, otherwise $|\text{err}\rangle\langle\text{err}|$ at the C_2 interface. We now need to prove that

$$\pi_{c_1}^{e''} \pi_{c_2}^{d''} (\mathcal{K} \| \mathcal{C}^{\text{q-insec}} \| \mathcal{C}^{\text{c-auth}} \| \mathcal{S}_1^{\text{bv}} \| \mathcal{S}_2^{\text{bv}}) \underset{\epsilon^{\text{q-sec}}}{\approx} \mathcal{S}^{2\text{-bv}} \sigma_s^{\text{q-sec-m}}. \quad (13)$$

Eq. (13) follows from Eq. (12), because an optimal strategy for the distinguisher consists of allowing the correct computation to be performed, which is the case covered by Eq. (12). If the distinguisher provokes an error, then Client₂ will simply output an error, and the distinguisher has less information available to try to distinguish the real from the ideal systems. Also revealing the accept/reject bit does not change the distance because the distinguisher has access to all interfaces, which contain the accept/reject information. Based on Eq. (2) plugging simulators σ_s^{bv} on the real and ideal systems cannot increase their distance, so we have

$$\pi_{c_1}^{e''} \pi_{c_2}^{d''} (\mathcal{K} \| \mathcal{C}^{\text{q-insec}} \| \mathcal{C}^{\text{c-auth}} \| \mathcal{S}_1^{\text{bv}} \| \mathcal{S}_2^{\text{bv}}) \sigma_s^{\text{bv}} \sigma_s^{\text{bv}} \underset{\epsilon^{\text{q-sec}}}{\approx} \mathcal{S}^{2\text{-bv}} \sigma_s^{\text{q-sec-m}} \sigma_s^{\text{bv}} \sigma_s^{\text{bv}}. \quad (14)$$

Now we can move the brackets around in the left-hand side of Equation (14), which could equivalently have been written:

$$\pi_{c_1}^{e''} \pi_{c_2}^{d''} (\mathcal{K} \| \mathcal{C}^{\text{q-insec}} \| \mathcal{C}^{\text{c-auth}} \| \mathcal{S}_1^{\text{bv}} \sigma_s^{\text{bv}} \| \mathcal{S}_2^{\text{bv}} \sigma_s^{\text{bv}}) \underset{\epsilon^{\text{q-sec}}}{\approx} \mathcal{S}^{2\text{-bv}} \sigma_s^{\text{q-sec-m}} \sigma_s^{\text{bv}} \sigma_s^{\text{bv}}. \quad (15)$$

The final step is to replace $\mathcal{S}_1^{\text{bv}} \sigma_s^{\text{bv}}$ and $\mathcal{S}_2^{\text{bv}} \sigma_s^{\text{bv}}$ by the real BV-DQC protocols. It is shown in Figure 6. Combining Eqs. (7) and (15) we obtain:

$$\pi_{c_1}^{e''} \pi_{c_2}^{d''} (\mathcal{K} \| \mathcal{C}^{\text{q-insec}} \| \mathcal{C}^{\text{c-auth}} \| \pi_{c_1}^{\text{bv}} \mathcal{R}_1 \| \pi_{c_2}^{\text{bv}} \mathcal{R}_2) \underset{\epsilon^{\text{q-sec}} + 2\epsilon^{\text{bv}}}{\approx} \mathcal{S}^{2\text{-bv}} \sigma_s^{\text{q-sec-m}} \sigma_s^{\text{bv}} \sigma_s^{\text{bv}}.$$

Moving brackets around we get:

$$\pi_{c_1}^{e''} \pi_{c_2}^{d''} \pi_{c_1}^{bv} \pi_{c_2}^{bv} (\mathcal{K} \| \mathcal{C}^{\text{q-sec}} \| \mathcal{C}^{\text{c-auth}} \| \mathcal{R}_1 \| \mathcal{R}_2) \underset{\epsilon^{\text{q-sec}} + 2\epsilon^{\text{bv}}}{\approx} \mathcal{S}^{2\text{-bv}} \sigma_s^{\text{q-sec-m}} \sigma_s^{bv} \sigma_s^{bv}.$$

Figure 6 demonstrates the concrete protocol and resources. Simply put, the composition of the authentication protocol and the BV-DQC protocols constructs the 2-client BV-DQC resource $\mathcal{S}^{2\text{-bv}}$ with error equal to $\epsilon^{\text{q-sec}} + 2\epsilon^{\text{bv}}$. The simulator $\sigma_s^{2\text{-bv}}$ is equal to $\sigma_s^{\text{q-sec-m}} \sigma_s^{bv} \sigma_s^{bv}$.

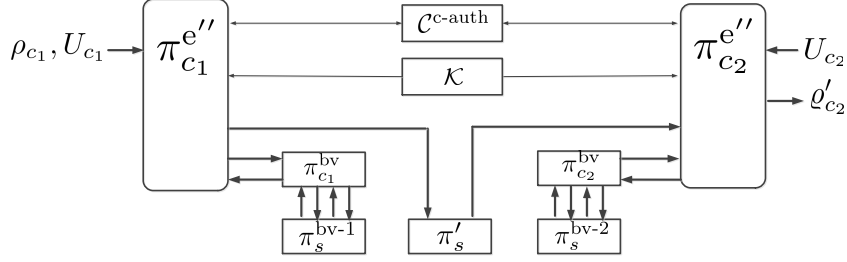

Fig. 6. The concrete protocol for implementing the example in Figure 3

The security proof can be directly extended to the case of a generic multi party DQC. In this case, the total error, $\epsilon^{n\text{-bv}}$ is the sum of the errors of all runs of BV-DQC and QAS. In the case of fully connected network with n clients and each with m unitaries, it is equal to:

$$\epsilon^{n\text{-bv}} = (mn)\epsilon^{\text{bv}} + n(n-1)(m-1)\epsilon^{\text{q-sec}},$$

where mn is the number of unitaries performed by the server, and $n(n-1)(m-1)$ is the number of sets of non-common qubits which require quantum authentication codes to be protected. ■

4 Reducing the quantum communications

In this section, we make an additional assumption about BV-DQC scheme which results in reducing the quantum communication between the clients and the server. To achieve this goal, first we define the ideal resource \mathcal{S}^{bb} which is used as a building block in the desirable particular structure of the BV-DQC protocol.

Definition 7. *The ideal DQC resource \mathcal{S}^{bb} has two interfaces C and S standing for the client and the server. It takes U and k' at the C interface and $E_{k'}\rho$ at the S interface, where $E_{k'}$ is an authentication map on qubits in ρ . The server also has a dishonest interface. It takes a filtered controlled bit f^{bb} at the S interface.*

If server sets $f^{\text{bb}} = 0$, \mathcal{S}^{bb} picks a uniformly random key k , outputs k at the C interface and applies $E_k U D_{k'}$ to $E_{k'} \rho$ and produces the honest result $E_k U \rho$ at the S interface. If $f^{\text{bb}} = 1$, the resource outputs the allowed leakage ℓ^{bb} at the S interface and some fixed error state $\chi = |\text{err}\rangle\langle\text{err}|$ orthogonal to the output space at the C interface.

Now suppose that the BV-DQC protocol π^{bv} is composed of the following converters as Figure 7 shows:

$$\pi^{\text{bv}} = \pi_c^e \pi_s^{\text{bb}} \pi_c^{\text{bb}} \pi_c^d, \quad (16)$$

which means that client's part of the protocol, π_c^{bv} , is decomposed into three parts; i) π_c^e , ii) π_c^{bb} , and iii) π_c^d as introduced in the following:

- i) π_c^e receives ρ and U at its outside interface. It requests a key k' and sends $E_{k'} \rho$ to the server.
- ii) π_c^{bb} receives U and k' from π_c^e . π_s^{bb} receives $E_{k'} \rho$ on its inside interface. π_s^{bb} and π_c^{bb} communicate with each other through \mathcal{R} to run the bulk of the DQC protocol, where $\pi_c^e \pi_c^{\text{bb}} \pi_s^{\text{bb}}$ constructs $\pi_c^e \mathcal{S}^{\text{bb}}$ within ϵ^{bb} , i.e.,

$$\pi_c^e \pi_c^{\text{bb}} \mathcal{R} \pi_s^{\text{bb}} \underset{\epsilon^{\text{bb}}}{\approx} \pi_c^e \mathcal{S}^{\text{bb}} \perp_s, \pi_c^e \pi_c^{\text{bb}} \mathcal{R} \underset{\epsilon^{\text{bb}}}{\approx} \pi_c^e \mathcal{S}^{\text{bb}} \sigma_s^{\text{bb}}, \quad (17)$$

therefore we can replace $\pi_c^{\text{bb}} \mathcal{R} \pi_s^{\text{bb}}$ by \mathcal{S}^{bb} in any context where the client runs π_c^e . In Eq. (17), we used the idea of context-restricted indistinguishability, which allows us to model a resource that does not compose generally but can only be used within a well-specified set of contexts [28]. π_c^{bb} passes two values to π_c^d ; the key k and a bit which indicates whether any cheating has been detected so far.

- iii) If the server behaves honestly, π_c^d receives $E_k U \rho$ from the server, it verifies the authenticity of this state, and if this test succeeds and π_c^d did not detect any cheating either, it outputs the result of the decryption (which should be $U \rho$), otherwise it outputs an error.

Protocol 3 is a modified blind verifiable multi-client DQC which removes the communications between the server and the clients between the rounds. Three types of protocols, BB1-DQC, BB-DQC, and BB2-DQC which are used in Protocol 3, are defined as follows:

- BB1-DQC(ρ, U) means $\pi_c^e \pi_s^{\text{bb}} \pi_c^{\text{bb}}$ is run which outputs $E_k U \rho$ and k , if the verification passes.
- BB-DQC($E_{k'} \rho, U, k'$) means $\pi_s^{\text{bb}} \pi_c^{\text{bb}}$ is run which outputs $E_k U \rho$ and k , if the verification passes.
- BB2-DQC($E_{k'} \rho, U, k'$) means $\pi_s^{\text{bb}} \pi_c^{\text{bb}} \pi_c^d$ is run which outputs $U \rho$, if the verification passes.

Protocol 3 Modified Blind Verifiable Multi-Client DQC (Removing the Communications Between the Clients and the Server)

- 1: Let n and m be the number of clients and the total number of local unitaries of each client, respectively.
 - 2: Let $i, j \in \{1, \dots, n\}$, $h \in \{1, \dots, m\}$, and $h' \in \{1, \dots, m-1\}$.
 - 3: Let ρ_i , $\mathcal{U}_i = \{U_i^{(h)}\}$, and ϱ_i be the input, the set of local unitaries and output of Client $_i$, respectively.
 - 4: Let $T_{i \rightarrow j}^{(h')}$ be the set of labels of qubits of $U_i^{(h')}$ that are fed into $U_j^{(h'+1)}$.
 - 5: Let (E_k, D_k) be a pair of keyed operations using for authenticating quantum states.

 - 6: **for** $i := 1$ to n **do**
 - 7: Client $_i$ and the server run BB1-DQC($\rho_i, U_i^{(1)}$).
 - 8: **if** error is detected **then**
 - 9: Client $_i$ sends $e = 1$ to the other clients through an authenticated classical channel and all clients abort the protocol.
 - 10: **else**
 - 11: the protocol outputs $\varrho_i^{(1)} = \otimes_j E_{k_{i \rightarrow j}^{(1)}} U_i^{(1)} \rho_i$ and $\{k_{i \rightarrow j}^{(1)}\}_{j \in \{1, \dots, n\}}$.
 - 12: **for** $j := 1$ to n **do**
 - 13: Client $_i$ sends $k_{i \rightarrow j}^{(1)}$ to Client $_j$.
 - 14: Let $\varrho_{i \rightarrow j}^{(1)}$ be the state of qubits in $T_{i \rightarrow j}^{(1)}$.
 - 15: **end for**
 - 16: **end if**
 - 17: **end for**
 - 18: **for** $i := 1$ to n **do**
 - 19: Let $\rho_i^{(2)} = \otimes_j \varrho_{j \rightarrow i}^{(1)}$.
 - 20: **end for**
 - 21: **for** $h := 2$ to $m-1$ **do**
 - 22: **for** $i := 1$ to n **do**
 - 23: Client $_i$ and the server run BB-DQC($\rho_i^{(h)}, U_i^{(h)}, \{k_{j \rightarrow i}^{(h-1)}\}_{j \in \{1, \dots, n\}}$).
 - 24: **if** error is detected **then**
 - 25: Client $_i$ sends $e = 1$ to the other clients through an authenticated classical channel and all clients abort the protocol.
 - 26: **else**
 - 27: the protocol outputs $\varrho_i^{(h)} = (\otimes_j E_{k_{i \rightarrow j}^{(h)}}) U_i^{(h)} (\otimes_j D_{k_{j \rightarrow i}^{(h-1)}}) \rho_i^{(h)}$ and $k_{i \rightarrow j}^{(h)}$.
 - 28: **for** $j := 1$ to n **do**
 - 29: Client $_i$ sends $k_{i \rightarrow j}^{(h)}$ to Client $_j$.
 - 30: Let $\varrho_{i \rightarrow j}^{(h)}$ be the state of qubits in $T_{i \rightarrow j}^{(h)}$.
 - 31: **end for**
 - 32: **end if**
 - 33: **end for**
 - 34: **for** $i := 1$ to n **do**
 - 35: Let $\rho_i^{(h+1)} = \otimes_j \varrho_{j \rightarrow i}^{(h)}$.
 - 36: **end for**
 - 37: **end for**
 - 38: **for** $i := 1$ to n **do**
 - 39: Client $_i$ and the server run BB2-DQC($\rho_i^{(m)}, U_i^{(m)}, \{k_{j \rightarrow i}^{(m)}\}_{j \in \{1, \dots, n\}}$)
 - 40: **if** error is detected **then**
 - 41: Client $_i$ sends $e = 1$ to the other clients through an authenticated classical channel and all clients abort the protocol.
 - 42: **else**
 - 43: the protocol outputs $\varrho_i^{(m)} = U_i^{(m)} (\otimes_j D_{k_{j \rightarrow i}^{(m-1)}}) \rho_i^{(m)}$
 - 44: **end if**
 - 45: **end for**
-

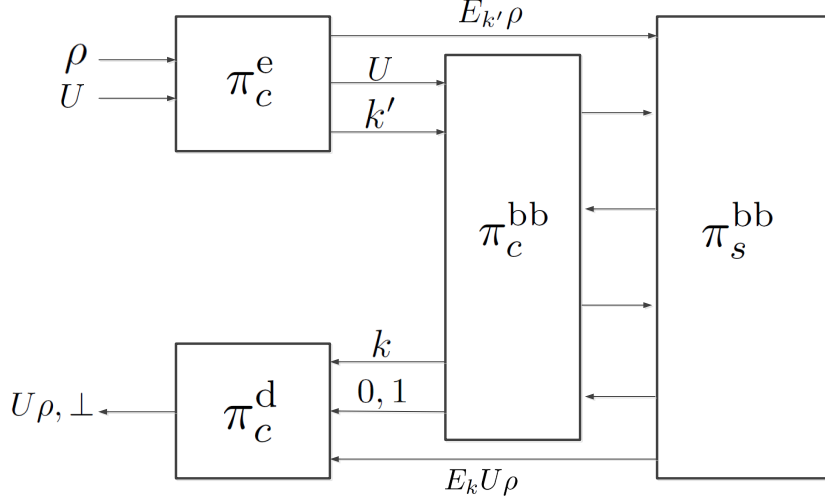

Fig. 7. The converter related to the particular type of BV-DQC protocol which results in decreased overhead in the multi-client DQC protocol.

4.1 Security Proof

Theorem 2. Protocol 3 constructs $\mathcal{S}^{n\text{-bv}}$ using resources \mathcal{K} , \mathcal{R}_1 , \mathcal{R}_2 and $\mathcal{C}_a^{\text{c-auth}}$, with error $\epsilon^{n\text{-bv}} = (mn)\epsilon^{\text{bb}} + n(n-1)(m-1)\epsilon^{\text{q-sec}} + 2n\epsilon^{\text{q-sec}}$, where n and m are the numbers of clients and each client's unitaries respectively.

Proof. Again, we first prove the security for the example in Figure 3 with two clients. We show that Protocol 4 constructs $\mathcal{S}^{2\text{-bv}}$ using \mathcal{K} , \mathcal{R}_1 , \mathcal{R}_2 and $\mathcal{C}^{\text{c-auth}}$, with error $\epsilon^{2\text{-bv}} = 2\epsilon^{\text{bb}} + 3\epsilon^{\text{q-sec}}$. The proof is easily extended to the general case. The proof is essentially similar to the proof of the previous section. First, we suppose the parties have access to the quantum capabilities, but we decompose the protocol in a slightly different way of the previous section. The protocol is composed of the following converters:

$$\pi_{c_1}^{e_1} \pi_{c_1}^{d_1} \pi_{c_1}^{u_1} \pi_{c_1}^{e_2} \pi_{c_2}^{d_2} \pi_{c_2}^{u_2} \pi_{c_2}^{e_3} \pi_{c_2}^{d_3}.$$

The converter $\pi_{c_1}^{e_1}$ receives ρ_{c_1} at its outside interface. It requests a key k_1 from \mathcal{K} . It applies the map E_{k_1} to ρ_{c_1} which outputs the state τ_1 . $\pi_{c_1}^{d_1}$ receives τ_1' at its outside interface. It receives the key k_1 from \mathcal{K} and applies D_{k_1} which outputs ρ_{c_1} or $|\text{err}\rangle\langle\text{err}|$, depending on whether verification succeeds or fails. If verification succeeds, the converter $\pi_{c_1}^{u_1}$ receives U_{c_1} and ρ_{c_1} at its outside and inside interfaces respectively and outputs $U_{c_1}\rho_{c_1}$. The converter $\pi_{c_1}^{e_2}$ receives $U_{c_1}\rho_{c_1}$ at its inside interface. It requests a key k_2 from \mathcal{K} and outputs $\tau = E_{k_2}U_{c_1}\rho_{c_1}$ through $\mathcal{C}^{\text{q-insec}}$. The converter $\pi_{c_2}^{d_2}$ receives the key k_2 from \mathcal{K} and a (possibly) tampered state τ' and applies verification map D_{k_2} . It outputs

the state $U_{c_1}\rho_{c_1}$ if verification succeeded, or $|\text{err}\rangle\langle\text{err}|$ otherwise. If verification succeeded, the converter $\pi_{c_2}^{u_2}$ receives $U_{c_1}\rho_{c_1}$ at its inside interface and U_{c_2} at its outside interface and outputs $U_{c_2}U_{c_1}\rho_{c_1}$. $\pi_{c_2}^{e_3}$ requests a key k_3 from \mathcal{K} , applies E_{k_3} and outputs $E_{k_3}U_{c_2}U_{c_1}\rho_{c_1}$. $\pi_{c_2}^{d_3}$ receives a possibly tampered state and the key k_3 from \mathcal{K} . It outputs $\varrho_{c_2} = U_{c_2}U_{c_1}\rho_{c_1}$ if verification passes, otherwise it outputs $|\text{err}\rangle\langle\text{err}|$. Based on Eq.(8), we have:

$$\begin{aligned} \pi_{c_1}^{u_1}\pi_{c_2}^{u_2}\pi_{c_1}^{e_1}\pi_{c_2}^{d_1}\pi_{c_1}^{e_2}\pi_{c_2}^{d_2}\pi_{c_1}^{e_3}\pi_{c_2}^{d_3}(\mathcal{K}||\mathcal{C}^{\text{q-insec}}||\mathcal{C}^{\text{c-auth}}) &\underset{3\epsilon^{\text{q-sec}}}{\approx} \\ \pi_{c_1}^{u_1}\pi_{c_2}^{u_2}\mathcal{C}^{\text{q-sec}}\sigma_s^{\text{q-sec}}\mathcal{C}^{\text{q-sec}}\sigma_s^{\text{q-sec}}\mathcal{C}^{\text{q-sec}}\sigma_s^{\text{q-sec}}\mathcal{C}^{\text{q-sec}}\sigma_s^{\text{q-sec}} & \end{aligned}$$

Now we have:

$$\pi_{c_1}^{u_1}\pi_{c_2}^{u_2}\mathcal{C}^{\text{q-sec}}\sigma_s^{\text{q-sec}}\mathcal{C}^{\text{q-sec}}\sigma_s^{\text{q-sec}}\mathcal{C}^{\text{q-sec}}\sigma_s^{\text{q-sec}}\mathcal{C}^{\text{q-sec}}\sigma_s^{\text{q-sec}} = \mathcal{S}'\sigma_s^{\text{q-sec}}\sigma_s^{\text{q-sec}}\sigma_s^{\text{q-sec}}, \quad (18)$$

where \mathcal{S}' is the ideal channel where $\pi_{c_1}^{u_1}$ and $\pi_{c_2}^{u_2}$ have been merged with it. $\sigma_s^{\text{q-sec}}$ behaves the same as $\sigma_s^{\text{q-sec}}$, but it also outputs the leak of both communications $\ell_1^{\text{q-sec}}$ and $\ell_2^{\text{q-sec}}$, and waits to check if the messages have been sent or not. If so, $\sigma_s^{\text{q-sec}}$ tells \mathcal{S}' to output the correct value, otherwise $|\text{err}\rangle\langle\text{err}|$ at the C_2 interface. We move forward to the real case where the parties do not have quantum capabilities and delegate the computations (except E_{k_1} and D_{k_3}) to the resource \mathcal{S}^{bb} . With the similar analyses of the security proof in the previous section, we have:

$$\pi_{c_1}^{e_1}\pi_{c_2}^{d_3}(\mathcal{K}||\mathcal{C}^{\text{q-insec}}||\mathcal{C}^{\text{c-auth}}||\mathcal{S}_1^{\text{bb}}||\mathcal{S}_2^{\text{bb}}) \underset{3\epsilon^{\text{q-sec}}}{\approx} \mathcal{S}^{2\text{-bv}}\sigma_s^{\text{q-sec}}\sigma_s^{\text{q-sec}}\sigma_s^{\text{q-sec}}. \quad (19)$$

The simulator $\sigma_s^{\text{q-sec}}$ behaves the same as $\sigma_s^{\text{q-sec}}$, but it also outputs the leak of both computations ℓ_1^{bb} and ℓ_2^{bb} and waits for the server to say if it does the correct computation or not. If so, $\sigma_s^{\text{q-sec}}$ tells $\mathcal{S}^{2\text{-bv}}$ to output the correct value, otherwise $|\text{err}\rangle\langle\text{err}|$ at the C_2 interface. Now, plugging simulators σ_s^{bb} on the real and ideal systems does not increase their distance:

$$\pi_{c_1}^{e_1}\pi_{c_2}^{d_3}(\mathcal{K}||\mathcal{C}^{\text{q-insec}}||\mathcal{C}^{\text{c-auth}}||\mathcal{S}_1^{\text{bb}}\sigma_s^{\text{bb}}||\mathcal{S}_2^{\text{bb}}\sigma_s^{\text{bb}}) \underset{3\epsilon^{\text{q-sec}}}{\approx} \mathcal{S}^{2\text{-bv}}\sigma_s^{\text{q-sec}}\sigma_s^{\text{q-sec}}\sigma_s^{\text{q-sec}}\sigma_s^{\text{bb}}\sigma_s^{\text{bb}} \quad (20)$$

The final step is to replace $\mathcal{S}^{\text{bb}}\sigma_s^{\text{bb}}$ with the real BB-DQC protocols, $\pi_c^{\text{bb}} = (\pi_c^{\text{bb}}, \pi_s^{\text{bb}})$:

$$\pi_{c_1}^{e_1}\pi_{c_1}^{\text{bb}}\pi_{c_1}^{\text{bb}}\pi_{c_2}^{\text{bb}}\pi_{c_2}^{d_3}(\mathcal{K}||\mathcal{C}^{\text{q-insec}}||\mathcal{C}^{\text{c-auth}}||\mathcal{R}_1||\mathcal{R}_2) \underset{3\epsilon^{\text{q-sec}}+2\epsilon^{\text{bb}}}{\approx} \mathcal{S}^{2\text{-bv}}\sigma_s^{\text{q-sec}}\sigma_s^{\text{q-sec}}\sigma_s^{\text{q-sec}}\sigma_s^{\text{bb}}\sigma_s^{\text{bb}}.$$

So the composition of the authentication protocol and the BV-DQC protocols with the particular structure described above, constructs the 2-client BV-DQC resource, $\mathcal{S}^{2\text{-bv}}$ with error equal to $2\epsilon^{\text{bb}} + 3\epsilon^{\text{q-sec}}$. The security proof can be directly extended to the case of a generic multi party DQC. In this case the total error, $\epsilon^{\text{n-bv}}$ is the sum of the errors of all runs of BV-DQC and QAS. In the case of fully connected network, with n clients and each with m unitaries, it is equal to:

$$\epsilon^{\text{n-bv}} = (mn)\epsilon^{\text{bb}} + (n(n-1)(m-1) + 2n)\epsilon^{\text{q-sec}}.$$

■

Protocol 4 Modified Blind Verifiable Two-Client DQC for the Setting in Figure 3

- 1: Let ρ_{c_i} and U_{c_i} be the input and the local unitary. of C_i , respectively, where $i \in \{1, 2\}$
 - 2: Let (E_k, D_k) be a pair of operations for authenticating.
 - 3: Client₁ and the server run BB1-DQC(ρ_{c_1}, U_{c_1}).
 - 4: **if** error is detected **then**
 - 5: Client₁ sends $e = 1$ to Client₂ through an authenticated classical channel and both outputs $|\text{err}\rangle\langle\text{err}|$ and abort the protocol.
 - 6: **else**
 - 7: the protocol outputs $E_k U_1 \rho_{c_1}$ and k .
 - 8: Client₁ sends k to Client₂.
 - 9: **end if**
 - 10: Client₂ and the server run BB2-DQC($E_k U_1 \rho_{c_1}, U_2$) which outputs ρ_2 .
 - 11: **if** error is detected **then**
 - 12: Client₁ and Client₂ output $|\text{err}\rangle\langle\text{err}|$
 - 13: **else**
 - 14: Client₂ outputs $\rho_{c_2} = U_2 U_1 \rho_{c_1}$.
 - 15: **end if**
-

5 Conclusion

In this paper, we studied the multi-client DQC problem. In our setting, we considered the global unitary to be made up of local unitaries that are individually decided by the clients. Each client's part is kept secret from the server and the other clients (assuming honest client behaviour). We constructed a verifiable composable secure multi-client DQC scheme from any verifiable composable secure single-client DQC protocols and quantum authentication codes. We proved the security and then optimised the protocol by removing the quantum communication between the clients and the server.

Acknowledgements – The authors thank Christopher Portman for useful discussions and Mark M. Wilde for his comments on an earlier version of this manuscript. The authors acknowledge support from Singapore's Ministry of Education and National Research Foundation, and the Air Force Office of Scientific Research under AOARD grant FA2386-15-1-4082. This material is based on research funded in part by the Singapore National Research Foundation under NRF Award NRF-NRFF2013-01.

References

1. Ambainis, A., Mosca, M., Tapp, A., De Wolf, R.: Private quantum channels. In: Foundations of Computer Science, 2000. Proceedings. 41st Annual Symposium on. pp. 547–553. IEEE (2000)
2. Armbrust, M., Fox, A., Griffith, R., Joseph, A.D., Katz, R., Konwinski, A., Lee, G., Patterson, D., Rabkin, A., Stoica, I., et al.: A view of cloud computing. Communications of the ACM 53(4), 50–58 (2010)

3. Arrighi, P., Salvail, L.: Blind quantum computation. *International Journal of Quantum Information* 4(05), 883–898 (2006)
4. Barni, M., Failla, P., Kolesnikov, V., Lazzeretti, R., Sadeghi, A.R., Schneider, T.: Secure evaluation of private linear branching programs with medical applications. In: *European Symposium on Research in Computer Security*. pp. 424–439. Springer (2009)
5. Barnum, H., Crépeau, C., Gottesman, D., Smith, A., Tapp, A.: Authentication of quantum messages. In: *Foundations of Computer Science, 2002. Proceedings. The 43rd Annual IEEE Symposium on*. pp. 449–458. IEEE (2002)
6. Barz, S., Fitzsimons, J.F., Kashefi, E., Walther, P.: Experimental verification of quantum computation. *Nature physics* 9(11), 727–731 (2013)
7. Barz, S., Kashefi, E., Broadbent, A., Fitzsimons, J.F., Zeilinger, A., Walther, P.: Demonstration of blind quantum computing. *Science* 335(6066), 303–308 (2012)
8. Ben-Or, M., Crépeau, C., Gottesman, D., Hassidim, A., Smith, A.: Secure multi-party quantum computation with (only) a strict honest majority. In: *47th Annual IEEE Symposium on Foundations of Computer Science, 2006. FOCS'06*. pp. 249–260. IEEE (2006)
9. Ben-Or, M., Mayers, D.: General security definition and composability for quantum & classical protocols. *arXiv preprint quant-ph/0409062* (2004)
10. Broadbent, A., Fitzsimons, J., Kashefi, E.: Universal blind quantum computation. In: *50th Annual IEEE Symposium on Foundations of Computer Science, 2009. FOCS'09*. pp. 517–526. IEEE (2009)
11. Canetti, R.: Universally composable security: A new paradigm for cryptographic protocols. In: *Foundations of Computer Science, 2001. Proceedings. 42nd IEEE Symposium on*. pp. 136–145. IEEE (2001)
12. Canetti, R., Ishai, Y., Kumar, R., Reiter, M.K., Rubinfeld, R., Wright, R.N.: Selective private function evaluation with applications to private statistics. In: *Proceedings of the twentieth annual ACM symposium on Principles of distributed computing*. pp. 293–304. ACM (2001)
13. Childs, A.M.: Secure assisted quantum computation. *Quantum Information & Computation* 5(6), 456–466 (2005)
14. Crépeau, C., Gottesman, D., Smith, A.: Secure multi-party quantum computation. In: *Proceedings of the thirty-fourth annual ACM symposium on Theory of computing*. pp. 643–652. ACM (2002)
15. Dunjko, V., Fitzsimons, J.F., Portmann, C., Renner, R.: Composable security of delegated quantum computation. In: *International Conference on the Theory and Application of Cryptology and Information Security*. pp. 406–425. Springer (2014)
16. Dunjko, V., Kashefi, E.: Blind quantum computing with two almost identical states. *arXiv preprint arXiv:1604.01586* (2016)
17. Dunjko, V., Kashefi, E., Leverrier, A.: Blind quantum computing with weak coherent pulses. *Physical review letters* 108(20), 200502 (2012)
18. Dupuis, F., Nielsen, J.B., Salvail, L.: Secure two-party quantum evaluation of unitaries against specious adversaries. In: *Annual Cryptology Conference*. pp. 685–706. Springer (2010)
19. Dupuis, F., Nielsen, J.B., Salvail, L.: Actively secure two-party evaluation of any quantum operation. In: *Advances in Cryptology—CRYPTO 2012*, pp. 794–811. Springer (2012)
20. Fitzsimons, J.F., Kashefi, E.: Unconditionally verifiable blind computation. *arXiv preprint arXiv:1203.5217* (2012)
21. Gheorghiu, A., Kashefi, E., Wallden, P.: Robustness and device independence of verifiable blind quantum computing. *New Journal of Physics* 17(8), 083040 (2015)

22. Giovannetti, V., Maccone, L., Morimae, T., Rudolph, T.G.: Efficient universal blind quantum computation. *Physical review letters* 111(23), 230501 (2013)
23. Goldwasser, S.: Multi party computations: past and present. In: *Proceedings of the sixteenth annual ACM symposium on Principles of distributed computing*. pp. 1–6. ACM (1997)
24. Greganti, C., Roehsner, M.C., Barz, S., Morimae, T., Walther, P.: Demonstration of measurement-only blind quantum computing. *New Journal of Physics* 18(1), 013020 (2016)
25. Hajdušek, M., Pérez-Delgado, C.A., Fitzsimons, J.F.: Device-independent verifiable blind quantum computation. *arXiv preprint arXiv:1502.02563* (2015)
26. Hayashi, M., Morimae, T.: Verifiable measurement-only blind quantum computing with stabilizer testing. *Physical review letters* 115(22), 220502 (2015)
27. Huang, H.L., Zhao, Q., Ma, X., Liu, C., Su, Z.E., Wang, X.L., Li, L., Liu, N.L., Sanders, B.C., Lu, C.Y., et al.: Experimental blind quantum computing for a classical client. *Physical review letters* 119(5), 050503 (2017)
28. Jost, D., Maurer, U.: Context-restricted indifferenciability: Generalizing uce and implications on the soundness of hash-function constructions. *Cryptology ePrint Archive, Report 2017/461* (2017), <http://eprint.iacr.org/2017/461>
29. Kashefi, E., Pappa, A.: Blind multiparty quantum computing. *arXiv preprint arXiv:1606.09200* (2016)
30. Kashefi, E., Wallden, P.: Extending the delegated verifiable blind quantum computation functionality. *arXiv preprint arXiv:1606.06931* (2016)
31. Mantri, A., Demarie, T.F., Menicucci, N.C., Fitzsimons, J.F.: Flow ambiguity: A path towards classically driven blind quantum computation. *arXiv preprint arXiv:1608.04633* (2016)
32. Mantri, A., Pérez-Delgado, C.A., Fitzsimons, J.F.: Optimal blind quantum computation. *Physical review letters* 111(23), 230502 (2013)
33. Maurer, U.: Constructive cryptography—a new paradigm for security definitions and proofs. In: *Joint Workshop on Theory of Security and Applications*. pp. 33–56. Springer (2011)
34. Maurer, U., Renner, R.: Abstract cryptography. In: *Innovations in Computer Science*. Citeseer (2011)
35. Maurer, U., Renner, R.: From indifferenciability to constructive cryptography (and back). In: *Theory of Cryptography Conference*. pp. 3–24. Springer (2016)
36. Mohassel, P., Sadeghian, S.: How to hide circuits in mpc an efficient framework for private function evaluation. In: *Annual International Conference on the Theory and Applications of Cryptographic Techniques*. pp. 557–574. Springer (2013)
37. Mohassel, P., Sadeghian, S., Smart, N.P.: Actively secure private function evaluation. In: *International Conference on the Theory and Application of Cryptology and Information Security*. pp. 486–505. Springer (2014)
38. Morimae, T.: Continuous-variable blind quantum computation. *Physical review letters* 109(23), 230502 (2012)
39. Morimae, T.: Verification for measurement-only blind quantum computing. *Physical Review A* 89(6), 060302 (2014)
40. Morimae, T.: Measurement-only verifiable blind quantum computing with quantum input verification. *Physical Review A* 94(4), 042301 (2016)
41. Morimae, T., Dunjko, V., Kashefi, E.: Ground state blind quantum computation on akl state. *Quantum Information & Computation* 15(3-4), 200–234 (2015)
42. Morimae, T., Fujii, K.: Blind topological measurement-based quantum computation. *arXiv preprint arXiv:1110.5460* (2011)

43. Morimae, T., Fujii, K.: Blind quantum computation protocol in which alice only makes measurements. *Physical Review A* 87(5), 050301 (2013)
44. Pérez-Delgado, C.A., Fitzsimons, J.F.: Iterated gate teleportation and blind quantum computation. *Physical review letters* 114(22), 220502 (2015)
45. Pfitzmann, B., Waidner, M.: A model for asynchronous reactive systems and its application to secure message transmission. In: *Security and Privacy, 2001. S&P 2001. Proceedings. 2001 IEEE Symposium on*. pp. 184–200. IEEE (2001)
46. Pinkas, B., Schneider, T., Smart, N.P., Williams, S.C.: Secure two-party computation is practical (2009)
47. Popescu, S., Rohrlich, D.: Quantum nonlocality as an axiom. *Foundations of Physics* 24(3), 379–385 (1994)
48. Portmann, C.: Quantum authentication with key recycling. arXiv preprint arXiv:1610.03422 (2017)
49. Portmann, C., Matt, C., Maurer, U., Renner, R., Tackmann, B.: Causal boxes: quantum information-processing systems closed under composition. arXiv preprint arXiv:1512.02240 (2015)
50. Raussendorf, R., Briegel, H.J.: A one-way quantum computer. *Physical Review Letters* 86(22), 5188 (2001)
51. Sueki, T., Koshiha, T., Morimae, T.: Ancilla-driven universal blind quantum computation. *Physical Review A* 87(6), 060301 (2013)
52. Tanenbaum, A.S., et al.: *Computer networks*, 4-th edition. ed: Prentice Hall (2003)
53. Unruh, D.: Simulatable security for quantum protocols. arXiv preprint quant-ph/0409125 (2004)
54. Yao, A.C.: Protocols for secure computations. In: *23rd Annual Symposium on Foundations of Computer Science, SFCS'08*. pp. 160–164. IEEE (1982)