

A new generator of chaotic bit sequences with mixed-mode inputs

M. Melosik

*Poznan University of Technology, Department of Computer Science
Piotrowo 3A, 61-138 Poznan, POLAND*

W. Marszalek¹

*Rutgers University, Department of Mathematics
110 Frelinghuysen Rd., Piscataway, NJ 08854, USA*

Abstract

This paper presents a new generator of chaotic bit sequences with mixed-mode (continuous and discrete) inputs. The generator has an improved level of chaotic properties in comparison with the existing single source (input) digital chaotic bit generators. The 0–1 test is used to show the improved chaotic behavior of our generator having a chaotic continuous input (Chua, Rössler or Lorenz system) intermingled with a discrete input (logistic, Tinkerbell or Henon map) with various parameters. The obtained sequences of chaotic bits show some features of random processes with increased entropy levels, even in the cases of small numbers of bit representations. The properties of the new generator and its binary sequences compare well with those obtained from a truly random binary reference quantum generator, as evidenced by the results of the *ent* tests.

1. Introduction

Most well-known chaotic-based bit generators use a single source (input), either a continuous or discrete one [1, 2]. Such an approach may result in a bit

Email addresses: michal.melosik@put.poznan.pl (M. Melosik),
w.marszalek@rutgers.edu (W. Marszalek)

¹Corresponding author

sequence that can be compromised through a synchronization of chaotic systems [3]-[7], or a possible prediction of a bit sequence due to a finite precision number representation [8]-[10]. Those problems are strongly linked to the fact that the output of a single discrete input generator in the finite precision arithmetics becomes periodic (therefore nonchaotic) even if the length of the output sequence is of order 10^6 . Most studies on digital chaotic generators utilize the NIST² tests when the statistical properties (i.e. randomness of the sequences of 0s and 1s) are examined for the sequences of minimum length of 10^6 . Our paper differs from such an approach, as we are interested in improving the level of chaotic behavior (as measured by the parameter K below).

1.1. Historical perspective

The best approach to generate random binary sequences is to use a source with the highest possible entropy level. That level depends primary on the source itself, its “working” environment and possible unauthorized attempts to modify the source, for example through hacking. Fig. 1a shows a general idea of generating a random binary sequence. A chaotic bit generator serves as a source of a high entropy sequence. The binary sequences obtained from chaotic generators are called the *binary chaotic sequences*. To transform such sequences into binary random sequences it is necessary to post-process the chaotic sequences and apply corrections to eliminate instances of biased 0 and 1 bits (long intervals of bits of the same value). Typical method applied for that purpose is the von Neumann correction that is considered to be a randomness extractor [11].

In the correction process, the random bits of a sequence form pairs of two bits. Whenever the two bits of a pair are equal, the pair is discarded. When the two bits are different and the pair starts with a 1, the pair is replaced by a 1. When it starts with a 0, it is replaced by a 0. After such a correction, the bias is removed from the sequence. The von Neumann correction transforms a chaotic sequence into a random one, which is shorter than the original chaotic sequence.

²NIST = National Institute of Standards and Technology

Most of the methods of examining binary sequences are applied to the post-processed sequences, after the von Neumann correction had been applied. This paper takes a different approach and the binary chaotic sequences are analyzed and tested without being pre-processed. This allows for a direct analysis of the obtained bit sequences. The new mixed-mode input generator of chaotic bit sequences is tested with the 0–1 test for chaos to monitor the generator’s chaotic nature. Short bit sequences, apart from their chaotic dynamics, also have selected properties of random processes, confirmed through a computation of typical parameters, such as, the entropy level, compression, χ^2 and Monte-Carlo π numbers, and others. The sequences obtained from our mixed-mode input chaotic binary generator are compared with a reference binary sequence with high entropy level obtained from the Quantis generator [12].

1.2. Other issues of binary sequence generators

Increasing the number of bits used in the finite precision arithmetics may temporarily solve the problem of having a lower quality random sequence. However, the problem repeats again with the increased length of the output sequence, beyond the 10^6 order. In practical terms, increasing the length of the output sequence, say from order 10^6 to 10^7 does not solve the problem, since the longer sequence will eventually also become periodic [8]. In order to provide a solution to such problems we designed a new generator of chaotic bits with mixed-mode inputs. Such an approach increases the level of chaos, as it is much more difficult to predict the chaotic binary output of our generator. The parameters of the two (continuous and discrete) chaotic input systems can easily be modified each time the generator is run. It is shown that in the case of small number of bit representation the proposed generator works much better when compared with the single source chaotic bit generators. Our generator prevents periodicity and the obtained sequence is truly chaotic as evidenced by the results of the 0–1 test. The tests for randomness also show an improved quality (i.e. higher entropy levels) of the binary sequences obtained from the mixed-mode generator.

Also, the proposed generator with two parts, the discrete (logistic, Henon

or other map) and analog (Chua, Rössler or Lorenz system), can be modeled and analyzed using the hardware description language VHDL-AMS, which is an industry standard modeling language for mixed signal circuits. In this paper, however, we focus on analyzing dynamical properties and features of the proposed generator rather than its hardware implementations. The hardware realizations of the proposed generator will be the focus of further research.

2. New mixed-mode generator of chaotic bit sequences

Fig. 1b shows the structure of the new generator. The continuous input comes from a chaotic circuit of Chua, Rössler, Lorenz (or other), while the discrete input can be a logistic, Henon, Tinkerbell or Baker map. An example of a digital implementation of the logistic map in a finite precision number representation is shown in Fig. 1c. The logistic equation is: $x(n+1) = \mu x(n)[1 - x(n)]$ with $1 < \mu < 4$ and $0 < x(0) < 1$.

The continuous input in Fig. 1b is discretized and synchronized with the internal clock of the discrete chaotic map. The two binary signals $\{D_i\}$ and $\{C_j\}$ are mixed through the XOR operation. As a result, a sequence of bits $\{N_k\}$ is obtained. The 0–1 test is then applied to the sequence $\{N_k\}$ to check its chaotic nature. If the result of the test is satisfactory (see more details below), the $\{N_k\}$ sequence is used to form a new sequence of chaotic bits. Otherwise, a change of the parameters of the discrete chaotic map should be considered to yield a better test result. Another option to consider is to replace the discrete chaotic system by a different one. For example, one may consider replacing logistic map by Tinkerbell, Henon, Baker or other discrete map.

The choice of XOR operation of mixing two signals is due to two main reasons. First, the operation is relatively simple and does not require complicated circuit realization. Secondly, the operation is widely used to mix the transmitted data with secret keys in typical secure electronic transmission implementations. Also, as demonstrated in this paper, the XOR operation significantly improves the quality of the obtained chaotic sequence - see sections 5 and 6 below. Also, the generator performs very well even when a small number of bit representation

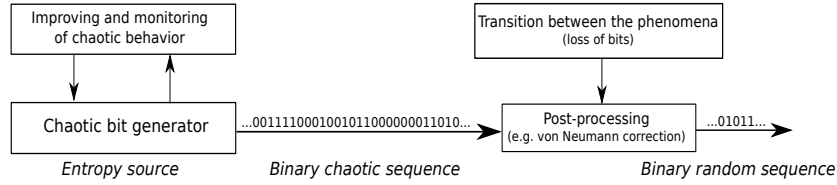

(a)

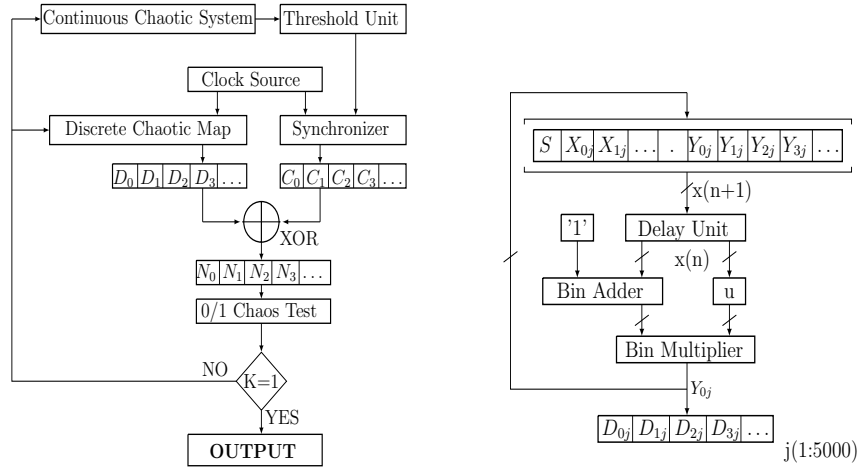

(b)

(c)

Figure 1: (a) Creating random sequences from chaotic ones through a correction, (b) schematic diagram of the chaotic generator with mixed-mode inputs, (c) example of a simplified digital fixed-point logistic map implementation.

is used. Another important factor is that the quality analysis of our generator is done through a relatively simple, but reliable tool, namely the 0–1 test, that can be implemented in a real time monitoring system.

3. Generation of chaotic bits

The chaotic behavior of the logistic map occurs for a certain range of the parameter μ . If the parameter value is chosen from that range, then for any initial condition $0 < x(0) < 1$, we obtain a sequence of real numbers in the interval $(0, 1)$. Each of those real numbers is represented as a fixed point number. Those numbers are implemented in the digital structure of the logistic map shown in Fig. 1c. The $[S|X_{0j}|X_{1j}|\dots|Y_{0j}|Y_{1j}|Y_{2j}|Y_{3j}|\dots]$ ¹ is a fixed point

number representation. The j index is the iteration number of the logistic map (or other implemented discrete map). The S denotes the sign bit. The sign is the same in all iterations of the logistic map, because $x(n) \in (0, 1)$ for all $n = 0, 1, 2, \dots$, but it may change from iteration to iteration when other discrete maps are used. The X_{ij} are the integer part bits, while the Y_{ij} are the fractional part bits, respectively, in the j th iteration. The output chaotic bits $\{D_i\}$ in Fig. 1c are obtained in each iteration by using a bit at a selected position (fixed in all iterations) in the sequence of consecutive fixed point numbers.

Chaotic bits from the continuous system result from a threshold unit, for example in the form of a simple comparator [2]. A synchronization unit is used to synchronize those bits with the occurrence of bits $\{D_i\}$. The discrete map is iterated to obtain $x(n + 1)$ when a bit from the continuous chaotic system is received. The two independent chaotic sequences $\{D_i\}$ and $\{C_i\}$ are mixed by the XOR operation. As a result, a new sequence of bits $\{N_k\}$ is obtained. This sequence is next tested by the 0–1 test for chaos [13, 14].

4. The 0–1 test for chaos

The 0–1 test is a relatively new tool used to test the presence of chaos in digital sequences when a mathematical model (system of equations) is not available. Thus, the 0–1 test is fundamentally different than the Lyapunov exponents method [15]. The result of the 0–1 test has two forms: a single real number $K \in (0, 1)$, and a two-dimensional graph with translation variables p_c and q_c [16, 17]. For a chaotic sequence the number K should be close to 1. Regular (nonchaotic) sequences result in numbers K closer to 0. The values of K can be computed by using two different methods: regression or correlation.

For the sequence $\{N_k\}$, $k = 0, 1, \dots, \overline{N} - 1$, the values p_c and q_c are computed by the following expressions for a randomly chosen real number number $c \in (0, \pi)$

$$p_c(n) = \sum_{j=0}^n N_j \cos[(j+1)c], \quad q_c(n) = \sum_{j=0}^n N_j \sin[(j+1)c] \quad (1)$$

for $n = 0, 1, \dots, \overline{N} - 1$. Then, the mean square displacement $M_c(n)$, $n =$

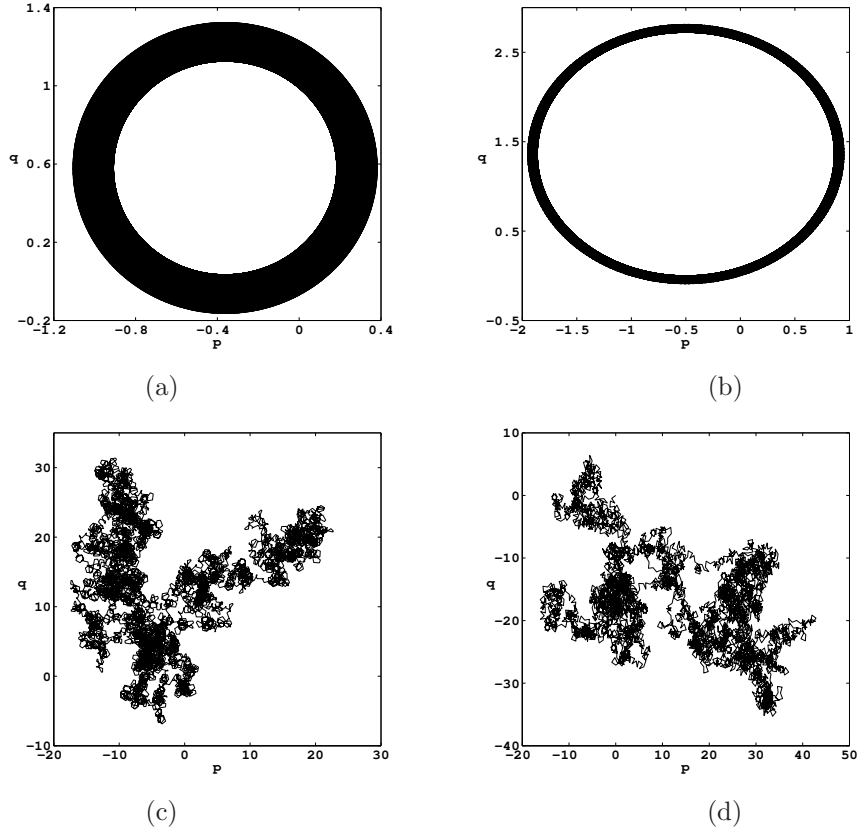

Figure 2: Variables $q - p$ for: (a) logistic map only with $\mu = 3.50$ yields $K = 0.0015$, (b) sequence of 7th bits from logistic map with $\mu = 3.50$ yields $K = 0.0025$, (c) logistic map only with $\mu = 3.99$ yields $K = 0.9982$, and (d) sequence of 7th bits from logistic map with $\mu = 3.99$ yields $K = 0.9980$.

$0, 1, \dots, n_{cut}$, of the variables $p_c(n)$ and $q_c(n)$ is computed with the recommended value $n_{cut} = (\bar{N} - 1)/10$ [14]

$$M_c(n) = \lim_{N \rightarrow \infty} \frac{1}{N-1} \sum_{j=0}^{\bar{N}-1} [p_c(j+n) - p_c(j)]^2 + [q_c(j+n) - q_c(j)]^2 \quad (2)$$

Next, if the regression method is applied, then the asymptotic growth rate K_c of the mean squared displacement is computed as follows

$$K_c = \lim_{n \rightarrow \infty} \frac{\log M_c(n)}{\log n}. \quad (3)$$

On the other hand, if the correlation method is applied, then two vectors $\Delta =$

$(M_c(0), M_c(1), M_c(2), \dots, M_c(n_{cut}))$ and $\xi = (0, 1, 2, \dots, n_{cut})$ are created. The correlation coefficient K_c is obtained as follows

$$K_c = corr(\xi, \Delta) \equiv \frac{cov(\xi, \Delta)}{\sqrt{var(\xi)var(\Delta)}} \quad (4)$$

where the *cov* and *var* stand for covariance and variance, respectively.

In both methods the above steps are repeated for N_c values of c chosen randomly in the interval $(0, \pi)$. Again, papers [13, 14] recommend $N_c = 100$. Finally, the median of the N_c values of K_c is the final number K . The $K \approx 1$ indicates a chaotic sequence of bits, while $K \approx 0$ indicates regular dynamics. More details about the 0–1 test, its properties, reliability, comparison with the FFT approach and application in the hardware trojan detection problems are considered in [17, 18].

Based on the sequences of p_c and q_c values one can create two-dimensional plots of q_c versus p_c . For regular (nonchaotic) or weakly chaotic sequences (i.e. K close to 0 or significantly lower than 1, respectively), the q_c versus p_c plot has a regular two-dimensional shape, while for chaotic sequences (i.e. K close to 1) the shape is irregular. Numerical examples with both regular and irregular plots are given in the next section. In the examples we use the correlation method and drop the index c in further analysis.

5. Computational results

We used sequences of 5000 numbers in all our calculations. Also, $n_{cut} = 10$ and $N_c = 100$. Such values are suggested, for example, in [16].

First, we used the above approach to analyze the logistic map only, without a continuous chaotic system. For $\mu = 3.50$ the following two cases were considered. First, we examined a sequence of real numbers from the logistic map. The $q - p$ plot is shown in Fig. 2a. Then, in the second case, the sequence of real numbers from the previous case was transformed to a respective fixed point representation. We selected a particular bit position and tested a sequence of bits from the consecutive fixed-point numbers, i.e. from each fixed-point number we selected a single bit of $\{Y_{0j}\}$ in Fig. 1c (on the 7th position) and

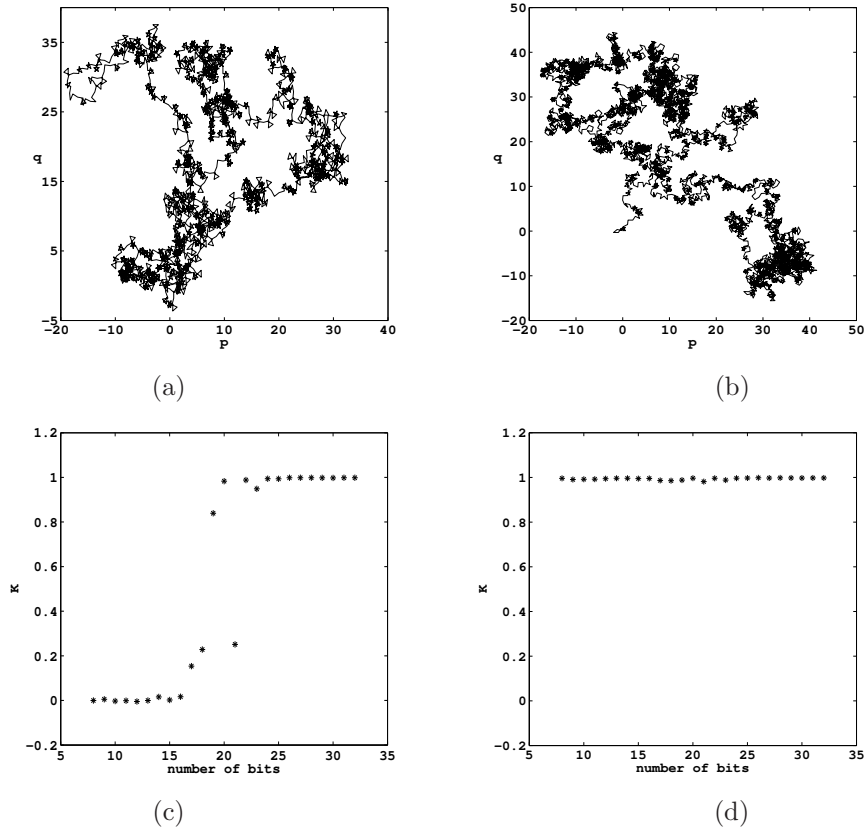

Figure 3: (a) variables $q - p$ for a sequence of 7th bits of logistic map with $\mu = 3.50$ XORed with chaotic bits of the Chua (Matsumoto) circuit yield $K = 0.9974$, (b) same as in part (a) but for $\mu = 3.99$ results in $K = 0.9984$, (c) K values for various number of bits between 8 and 32 (horizontal axis) for a sequence of 7th bits from the logistic map with $\mu = 3.99$, (d) same as in part (c) but the sequence of 7th bits from logistic map was XORed with the bits resulting from the continuous Chua (Matsumoto) circuit.

formed a sequence of bits taken from that selected position. Choosing the 7th position has no particular significance, and any other position could also be used. However, using a single bit position may have a significant impact and be an efficient implementation method when hardware resources are limited, for example in FPGA devices. In this paper the logistic map is used in fixed point representation. Fig. 2b shows the $q - p$ plot obtained in the second case. Since for $\mu = 3.50$ the logistic map gives a nonchaotic signal, therefore, in both cases, the obtained $q - p$ graphs are of regular shape as shown in Figs. 2ab. An

interesting result of our analysis is the fact that the nonchaotic nature of the sequence of real numbers (the first case above) is transformed into a nonchaotic nature of the sequence of bits $\{D_i\}$ (obtained from a selected single bit position as described in the second case above). The K values in the two cases above are 0.0015 and 0.0025, respectively. These numbers clearly indicate a nonchaotic nature of the analyzed sequences.

The same two cases were analyzed for the logistic map with $\mu = 3.99$ which result in chaotic behavior. The corresponding $q - p$ plots are shown in Figs. 2cd, respectively. The irregular shapes in Figs. 2cd indicate a chaotic nature of the sequences. The corresponding K values are now very close to the number 1 and equal 0.9982 and 0.9980, respectively.

Further, Figs. 3ab show the $q - p$ results for the proposed mixed-mode generator with a continuous chaotic Chua generator XORed the logistic map with a nonchaotic sequence ($\mu = 3.50$, Fig. 3a) and also with a chaotic one ($\mu = 3.99$, Fig. 3b). The K values are equal 0.9974 and 0.9984, respectively.

The Chua (or other analog chaotic generator) can be realized as a hardware device (with elements R , L , C and diodes together with op-amps) or as a software implementation - discretization of solutions of systems of differential equations [19].

Figs. 4cd show the results of applying the 0–1 test when a sequence of $7th$ bits were used for generated numbers with various bit lengths of sequence Y (between 8 and 32). Logistic map with $\mu = 3.99$ was used. It is clear from Fig. 4c that the chaotic sequences (the K values close to 1) are obtained for numbers of length 22 and more bits. All numbers of 16 and fewer bits indicate regular (nonchaotic) sequences formed of the $7th$ bits. If the sequences of $7th$ bits (from logistic map) are XORed with the bits resulting from the continuous chaotic Chua (Matsumoto) circuit [19], then all the new sequences show chaotic nature with K values close to 1, as shown in Fig. 4c. Moreover, we also fixed the length of numbers obtained from the logistic map (with $\mu = 3.99$) to be 18 bits and, as shown in Fig. 4c, we obtained $K = 0.2079$ for the sequence of $7th$ bits. The corresponding $q - p$ plot is shown in Fig. 4a. The $q - p$ plot is

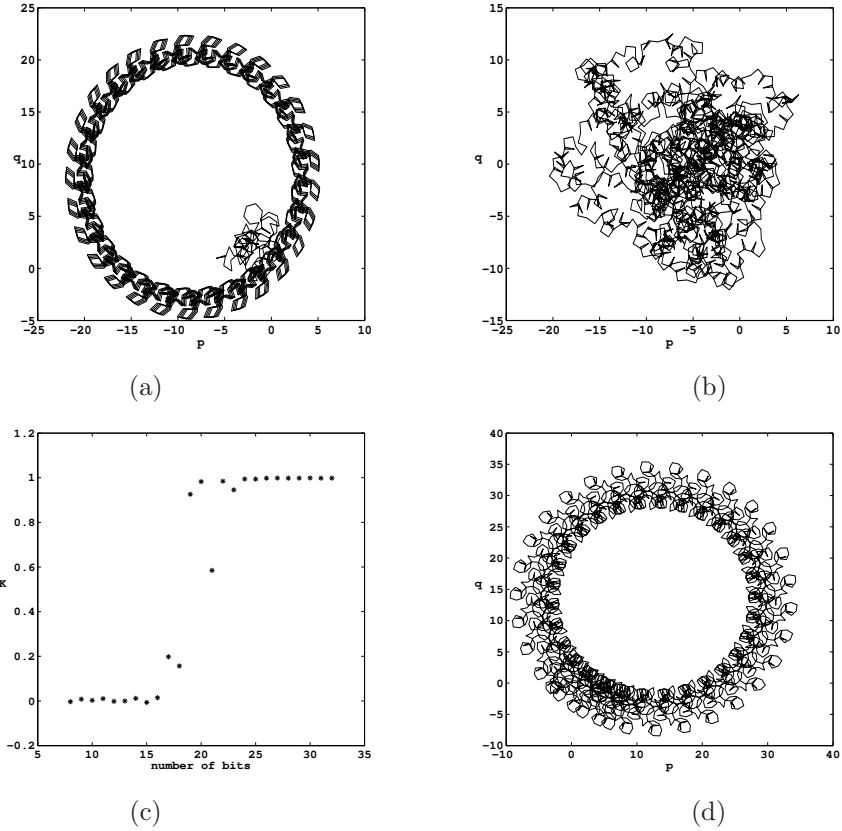

Figure 4: (a) variables $q - p$ without the XOR operation (chaotic bits from the Chua (Matsumoto) circuit). Logistic map with $\mu = 3.99$ was used for a sequence of 7th bits with numbers of length 18 bits ($K = 0.2079$), (b) same as in (a) but with the XOR operation ($K = 0.9874$), (c) K values for various number of bits of $\{Y_{0j}\}$ in Fig. 1c between 8 and 32 and the sequence of 7th bits from logistic map with $\mu = 3.99$, (d) variables $q - p$ for a sequence of 7th bits when the total length of each number is 21 bits. The $K = 0.6038$ (Fig. 4c for the *number of bits=21*).

fairly regular (as expected for $K = 0.2079$) and the sequence of 7th bits can, at best, be classified as *weakly chaotic*. The same sequence, when XORed with a sequence obtained from continuous Chua (Matsumoto) circuit gives $K = 0.9874$ and the $q - p$ plot is irregular, as shown in Fig. 4b.

Fig. 4c shows a result similar to that of Fig. 3c, but it illustrates another interesting fact about the 0–1 test. Notice that for a sequence with 21 bit representation we obtain $K = 0.6038$, which is almost in the middle between

the 0 and 1 values. The $q - p$ plot for this case is shown in Fig. 4d. The case can be classified as *weak chaos* with a fairly regular plot $q - p$.

We also examined our mixed-mode generator of chaotic bit sequences with various values of μ ($3.11 \leq \mu \leq 3.99$) and XOR operation with other continuous chaotic systems, such as, the Chua system with Kennedy diode, Rössler and Lorenz chaotic continuous systems. The obtained K values in all such cases were all greater than 0.99 with differences in the third and fourth decimal digits.

Figs. 5ab show the bit sequences $\{D_i\}$, $\{C_l\}$ and $\{N_k\}$ for the Chua (Matsumoto) system with logistic map ($\mu = 3.99$, Fig. 5a) and the Lorenz system with logistic map ($\mu = 3.99$, Fig. 5b). The $\{N_k\}$ sequences yield $K = 0.9981$ and $K = 0.9983$ in Fig. 5a and Fig. 5b, respectively. Fig. 6 shows the result of using logistic map for $\mu = 3.99$ and 12-bit precision of $\{Y_{0j}\}$. The value of $\mu = 3.99$ should indicate a chaotic dynamics. However, due to a small number of bits used, we obtain a non-chaotic (or *regular*) sequence $\{D_i\}$. The *regular* sequence $\{D_i\}$ and chaotic sequence $\{C_l\}$ (Chua (Matsumoto) circuit) are XOR-ed to yield a new chaotic sequence $\{N_k\}$. The three sequences $\{D_i\}$, $\{C_l\}$ and $\{N_k\}$ in Fig. 6 are characterized by the values of K equal 0.0011, 0.9980 and 0.9950, respectively. Thus, Fig. 6 illustrates the case when one of the two input sources is regular (non-chaotic sequence $\{D_i\}$) and yet, thanks to the XOR operation with another source sequence (with relatively small number of precision bits), we obtain a strong chaotic sequence $\{N_k\}$. Thus the analog part of the generator (Chua circuit) assures that the overall performance is firmly chaotic ($K = 0.9950$), despite the fact that a *regular* sequence ($K = 0.0011$) is obtained from the discrete part (logistic map) of the generator.

6. Mixed-mode input chaotic generator: quality of randomness

In the previous section we analyzed the chaotic dynamics of the generated bit sequences. In this section we evaluate whether or not the chaotic bit sequences have any features of random processes. It should be underlined that the chaos phenomenon is not equivalent to a random one. Some chaotic sequences show only selected random features, depending on the length of the analyzed data.

The goal now is to test if the mixed-mode generator's chaotic sequences exhibit similar random features as the ideal random quantum generator does for sequences of short length.

6.1. The *ent* tests

The binary sequences obtained from the mixed-mode generator were tested by the *ent* software and its various tests for randomness [20]. A sequence of bits is first transformed by *ent* into ASCII characters. Then the sequence of ASCII characters undergoes six independent tests, as follows [21].

- Entropy level test. For a sequence of ASCII characters we obtain randomness if the entropy level is around the value of 8. The lower the entropy level, the more likely it is to have a non-random sequence of ASCII characters.
- Compression test. Random sequences should have their compression levels close to 0%.
- χ^2 (chi-square) test. Randomness is confirmed in this test if a sequence falls into the interval of 10% to 90%. As explained in [20], such an interval is achieved primarily in the case of radioactive isotope decays. Also, the chi-square distribution is calculated for the stream of bytes in the sequence and expressed as two values: an absolute number and a percentage which indicates how frequently a truly random sequence would exceed the value calculated. For example, the result of (213.91; 95%) indicates a sequence with the χ^2 distribution of 213.91, and the sequence would exceed randomly that value 95% of the times.
- Arithmetic Mean Value (AMV) test with the output value close to 127.5 for random sequences. In this test all input bytes are summed up and divided by the total number of bytes.
- Monte-Carlo π (MC π) test indicating a random sequence if the result is a single percentage digit. For very long input streams this value will be close to 0, meaning an accurate approximation of the number π [20].

- Serial Correlation Coefficient (SCC) test yielding the number close to 0.0 for random sequences. This test checks dependence of each byte on a previous one. If there is no dependence between bytes, then the SCC value is close to 0.0.

The details of the tests can be found in [20, 21]. All types of chaotic bit sequences discussed in this paper were tested by the above six tests. We list these sequences in Table 1 and mark them as sequences s_1, s_2, \dots, s_9 . The most important test for randomness is, in our opinion, the entropy test. Therefore, as a reference sequence s_1 we selected a sequence obtained from a commercially available quantum generator Quantis manufactured by the Swiss firm [12]. We used the model USB-4M with the serial number 163109A410 supported by Quantique’s official “True Quantum Randomness Certificate” [22]. The sequence s_1 , as the one with excellent parameters (perhaps with the exception of the χ^2 value), is a reference sequence to which we relate all other chaotic sequences, including those obtained with the XOR operation in our mixed-mode generator.

Table 1: Sources of bits sequences tested by *ent*

sn	Source
s1	Quantis’ reference sequence of high entropy [12]
s2	Lorenz chaotic bits
s3	Chua chaotic bits
s4	Logistic chaotic bits (32 bit sequence $\{Y_{7j}\}$, see Fig.1c)
s5	Logistic chaotic bits (10 bit sequence $\{Y_{7j}\}$, see Fig.1c)
s6	sequence s2 XOR sequence s4
s7	sequence s3 XOR sequence s4
s8	sequence s2 XOR sequence s5
s9	sequence s3 XOR sequence s5

6.2. Analysis of test results

Fig. 7 shows examples of scatter plots of s_1 – s_9 , each consisting of 10,000 bits stacked in rows of 100 bits. Visual and rather subjective observation of the nine sequences in Fig. 7 indicates that the scatter plots of sequences s_6 ($= s_2$ XOR s_4) and s_7 ($= s_3$ XOR s_4) are very close to the *ideal* sequence s_1 . The scatter plot obtained from the logistic equation with 32 bit representation

(sequence s_4) also seems to be of good quality, but the same logistic equation yields much worse scatter plot if 10 bits are used only (sequence s_5). The scatter plots of sequences s_2 and s_3 seem to be of low quality when compared to the scatter plot of s_1 . Sequences s_2 and s_3 and their scatter plots depend heavily on the threshold value of the Threshold Unit in Fig. 1b as well as on the method of registering of chaotic bits and the frequency of the internal clock. Those parameters should be adjusted experimentally for various chaotic systems. The scatter plot of s_9 ($= s_3$ XOR s_5) confirms, at least visually, that the low quality sequence s_5 has been improved after the XOR operation. The above visual observations of the scatter plots in Fig. 7 are, to large extent, confirmed by the results of the six *ent* tests, which are analyzed below. The

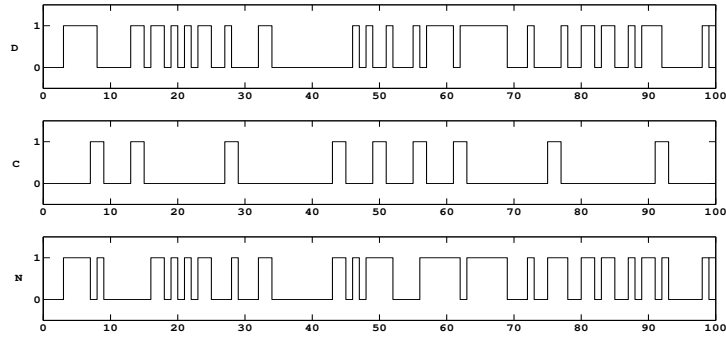

(a)

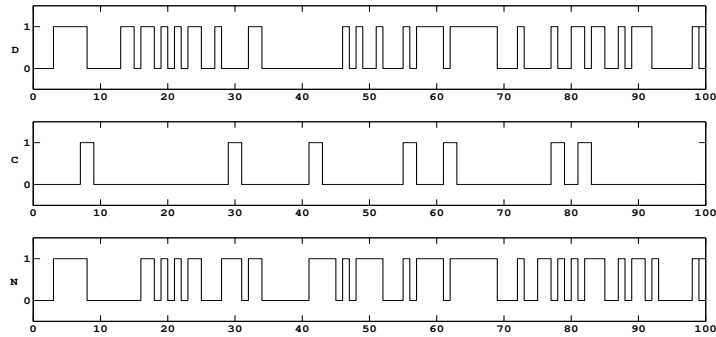

(b)

Figure 5: (a) sequences $\{D_i\}$, $\{C_i\}$ and $\{N_k\}$ obtained from the Chua (Matsumoto) system and logistic map with $\mu = 3.99$, (b) same as in (a) but for Lorenz system and logistic map.

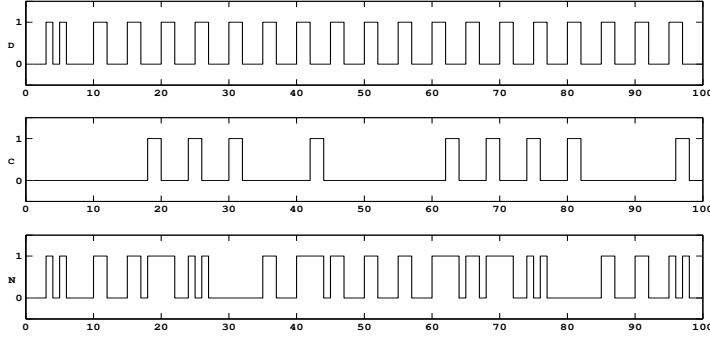

Figure 6: Sequences as in Fig. 5 with a relatively small number of precision bits resulting in a nonchaotic sequence $\{D_i\}$.

results shown in Table 2 for sequences $s2$ (Lorenz binary chaotic sequence) and $s3$ (Chua binary chaotic sequence) indicate relatively low entropy level, much lower than the desired value of 8. This is caused by the bias phenomenon - long intervals of the same bits. Thus, neither $s2$ nor $s3$ can be considered as a random sequence with high levels of entropy and the von Neumann correction is certainly recommended to those individual sequences. The logistic chaotic bit sequence $s4$ performs surprisingly well with a high entropy level (the length of data in $\{Y_j\}$ in Fig. 1c is 32 bits), and much poorer if the length is only 10 bits (sequence $s5$ in Table 2). The $s4$ sequence is generated by the system in Fig. 1c. There is a danger of having a repeated, identical sequences $s4$, if the system uses the same initial seed value. This can happen when an unauthorized (hacking) event occurs.

Table 2: Results of 6 *ent* tests performed on sequences $s1-s9$

sn	Entropy	Comp. %	χ^2 value; %	AMV	MC π %	SCC
s1	7.869559	1	213.91; 95	127.4415	1.07	0.005292
s2	3.884870	51	36200.14; 0.01	62.4149	21.87	0.119915
s3	1.829749	77	162993.87; 0.01	39.1188	27.32	0.111901
s4	7.850575	1	263.07; 50	131.5946	4.81	0.051919
s5	2.845031	64	44492.49; 0.01	181.7886	44.22	0.037565
s6	7.851689	1	251.59; 50	129.7392	2.06	0.013551
s7	7.837249	2	270.84; 25	131.6376	2.67	0.043232
s8	6.266494	21	5044.32; 0.01	155.7672	16.14	0.102282
s9	4.512645	43	22535.47; 0.01	166.5360	32.67	0.073107

Also, having a finite number of bits available to represent initial condition (seed value), there is a danger of inserting the same seed value after many repeated cycles of using a single input logistic-based generator. Such a generator will output sequences that had already been generated before. In order to secure a much wider diversity in creating chaotic sequences with excellent randomness features, we examined how the sequences obtained from our mixed-mode generator, perform in the six tests. The sequences $s6$ and $s7$ (obtained by the XOR operation in our generator) show very good test results, certainly comparable with the results for sequence $s1$. One may argue that there is no significant improvement of the test result between the $s4$ and $s6$ (or $s7$) sequences. However, even in this case, using the mixed-mode generator we have the comfort of not having identical sequences that may be obtained when only a logstistic map is used with the same initial seed values. Clearly, if we use the logistic map only with data of 10 bits (sequence $s5$), then such a single source generator fails most of the tests and $s5$ is of a low entropy level. XORing either $s2$ with $s5$ or $s3$ with $s5$ in our mixed-mode generator, creates sequences $s8$ or $s9$, respectively. These sequences have better test results than $s5$ alone with the entropy level increased two-fold. There are also improved compression levels, AMV values and MC π percentages for $s8$ and $s9$ sequences when compared to the $s5$ sequence. Our results of the MC π test are at the desired 1-2% level for $s6$ and $s7$. Such results are typically obtained with much longer sequences [20]. The results of the χ^2 test for $s6$ and $s7$ are also much better than those of $s2$ and $s3$ (and even of $s1$). As described on the [23] site, the χ^2 values of weakly random sequences are large while small for random sequences. This is clearly seen from Table 2. Those results are also confirmed by the lower compression levels for $s6$ and $s7$, which are in the range of 1-2%, comparable with the compression level for $s1$. Also, let us not forget that **none** of the sequences $s6$, $s7$, $s8$, and $s9$ undergoes the von Neumann correction. Overall, these sequences have good characteristics of random sequences, often comparable with those obtained from the professional quantum random number generators, such as the one used in this paper to generate sequence $s1$.

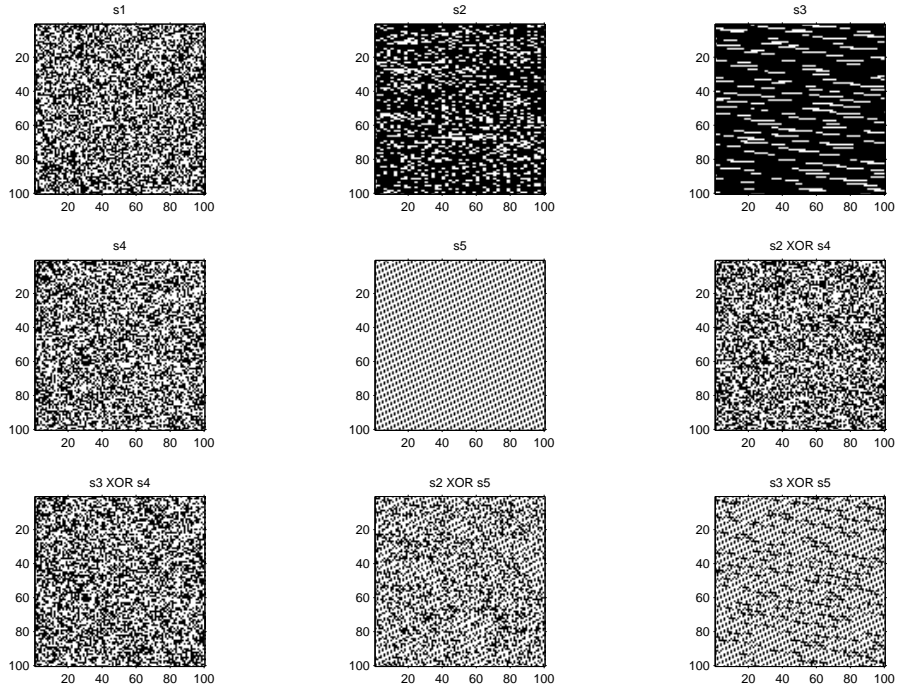

Figure 7: Scatter plots of sequences s_1 - s_9 , each with 10,000 bits.

7. Conclusion

At the present time the methods of designing of chaotic bit generators lack the protection against a potential of synchronization, and problems of finite length of bits in a number representation. Also, a possibility of reusing of the same seed values (initial conditions), obtained from chaotic generators to initialize pseudo-random algorithms, has not been properly addressed and examined yet [8]-[10]. To deal with those serious problems, we have proposed a new mixed-mode generator of chaotic bit sequences with an increased level of chaotic behavior (as evidenced by the increased parameter K in the 0-1 test). The improvement is due to mixing two independent chaotic inputs (continuous and discrete). The computational results confirm the *strong* chaotic nature of the generator's output as evidenced by the K values and irregularity of the $q-p$ shapes in the 0-1 test. The two chaotic sequences that we mix through

the XOR unit are also checked individually for their quality. Our generator exhibits *some* features of randomness without the von Neumann correction that is needed in most other chaotic based random bit generators. Also, it is worth mentioning that for shorter binary sequences, such as considered in this paper, the NIST statistical tests are not applicable. Therefore, we use the *ent* suite to examine the generator's performance and compare it with the performance of a truly random quantum reference generator of Quantis [12, 22]. Our chaotic generator can be assembled as a classical electronic circuit (continuous chaotic system) hooked up to a FPGA yielding a discrete chaotic system. In such a case, to model the whole generator one can use hardware description languages suitable to analyze mixed systems (continuous and discrete) [24]-[27]. Finally, our approach of taking the 7th bit in consecutive numbers is an efficient way to be implemented in FPGA devices when the hardware resources are very limited.

The future monitoring system built to check the real-time performance of the mixed-mode generator can utilize the graphical result in the form of a 2D $q - p$ plot, supplemented by the easy to interpret number K . A decrease of K from, say, 0.9950, through 0.8500 and further to, say, 0.7200 would indicate worsening the quality of chaotic output and could indicate improper work of the generator, due to a failure of electronic circuits generating the two input sequences. Another reason of decreasing the values of K could be unauthorized hardware modifications defined as hardware attacks or hardware trojans. They occur in the forms of parameter or circuit diagram changes, and became lately a *hot* research topic [28, 29].

References

- [1] Kanaso, A., Smaoui, N.: 'Logistic chaotic for binary numbers generations', *Chaos Solitons Fractals*, 2009, **40**, pp. 2557–2568
- [2] Yalcin, M. E., Suykens, J. A. K., Vandewalle, J.: 'True random bit generation from a double-scroll attractor', *IEEE Trans. Circuits Syst.-I: Regular Papers*, 2004, **51**, pp. 1394–1404

- [3] Posadas-Castillo, C., Cruz-Hernandez, C., Lopez-Gutierrez, R. M.: ‘Experimental realization of synchronization in complex networks with Chua’s circuits like nodes’, *Chaos Solitons Fractals*, 2009, **40**, pp. 1963–1975
- [4] Wu, X., Chen, G., Cai, J.: ‘Chaos synchronization of the master-slave generalized Lorenz systems via linear state error feedback control’, *Physica D*, 2007, **229**, pp. 52–80
- [5] Marszalek, W., Trzaska, Z. W.: ‘Memristive circuits with steady-state mixed-mode oscillations’, *Electr. Lett.*, 2014, **50**, pp. 1275–1277
- [6] Marszalek, W., Trzaska, Z. W.: ‘Mixed-mode oscillations and chaotic solutions of jerk (Newtonian) equations’, *J. Comp. Appl. Math.*, 2014, **262**, pp. 373–383
- [7] Yang, Y., Zhu, F.: ‘Synchronization for chaotic systems and chaos-based secure communications via both reduced-order and step-by-step sliding mode observers’, *Commun. Nonl. Sci. Numer. Simul.*, 2013, **18**, pp. 926–937
- [8] Persohn, K. J., Povinelli, R. J.: ‘Analyzing logistic map pseudorandom number generators for periodicity induced by finite precision floating-point representation’, *Chaos Solitons Fractals*, 2012, **45**, pp. 238–244
- [9] Alvarez, G., Li, S.: ‘Breaking an encrypted scheme based on chaotic baker map’, *Phys. Lett. A*, 2006, **352**, pp. 78–82
- [10] Özkaynaka, F., Yavuzb, S.: ‘Security problems for a pseudorandom sequence generator based on the Chen chaotic system’, *Computer Phys. Comm.*, 2013, **184**, pp. 2178–2181
- [11] Von Neumann, J.: ‘Various techniques used in connection with random digits’, *Appl. Math. Series*, 1951, **12**, pp. 36–38
- [12] ‘ID Quantique SA White Paper Version 3.0. Random number generation using quantum physics’, <http://www.idquantique.com>, accessed July 2017

- [13] Gottwald, G. A., Melbourne, I.: ‘A new test for chaos in deterministic systems’, *Proc. Royal Soc. London*, 2003, **460**, pp. 603–611
- [14] Gottwald, G. A., Melbourne, I.: ‘Testing for chaos in deterministic systems with noise’, *Physica D*, 2005, **212**, pp. 100–110
- [15] Marszalek, W., Trzaska, Z.: ‘Mixed-mode oscillations in a modified Chua’s circuit’, *Circuits Syst. Signal Proc.*, 2010, **29**, pp. 1075–1087
- [16] Gottwald, G. A., Melbourne, I.: ‘On the implementation of the 0–1 test for chaos’, *SIAM J. Appl. Dyn. Syst.*, 2009, **8**, pp. 129–145
- [17] Melosik, M., Marszalek, W.: ‘On the 0-1 test for chaos in continuous systems’, *Bull. Polish Acad. Sci., Tech. Sci.*, 2016, **64**, pp. 521–528
- [18] Melosik, M., Marszalek, W.: ‘Using the 0-1 test for chaos to detect hardware trojans in chaotic bit generators’, *Electr. Lett.*, 2016, **52**, pp. 919–920
- [19] Matsumoto, T., Chua, L. O., Komuro, M.: ‘The double scroll’, *IEEE Trans. Circuits Syst.*, 1985, **CAS-32**, pp. 798–818
- [20] Walker, J.: ‘ENT. A pseudorandom number sequence test program’, <http://www.fourmilab.ch/random/>, accessed Dec. 2017
- [21] Wen-Kai, Y., Shen, L., Xu-Ri Y., *et al.*: ‘A protocol based on compressed sensing for high-speed authentication and cryptographic key distribution over a multiparty optical network’, *Appl. Optics*, 2013, **52**, pp. 7882–7888
- [22] ‘ID Quantique Random Numbers’, <http://www.idquantique.com/random-number-generation/quantis-random-number-generator>, accessed Dec. 2017
- [23] ‘Embedded Device Hacking’, <http://www.devttys0.com/2013/06/differentiate-encryption-from-compression-using-math>, accessed Dec. 2017
- [24] Handkiewicz, A., Katarzynski, P., Szczesny, S., *et al.*: ‘Design automation of a lossless multiport network and its application to image filtering’, *Expert Syst. Appl.*, 2014, **41**, pp. 2211–2221

- [25] Handkiewicz, A., Szczesny, S., Naumowicz, M., *et al.*: ‘SI-Studio, a layout generator of current mode circuits’, *Expert Syst. Appl.*, 2015, **42**, pp. 3205–3018
- [26] Marszalek, W., Amdeberhan, T., Riaza, R.: ‘Singularity crossing phenomena in DAEs: a two-phase fluid flow application case study’, *Comp. Math. Appl.*, 2005, **49**, pp. 303-319
- [27] Campbell, S. L., Marszalek, W.: ‘Mixed symbolic-numerical computations with general DAEs II: An applications case study’, *Numerical Algorithms*, 1998, **19**, pp. 85-94
- [28] Melosik, M.: ‘Reconfigurable mixed-mode hybrid bit generator for chaos based cryptography’, *Ph.D. Thesis*, Poznan Univ. of Technology, Poland, 2017
- [29] Tehranipoor, M., C. Wang, C. (Eds.), *Introduction to hardware security and trust* (Springer, New York. 2012)