

Conformal nets IV: The 3-category

ARTHUR BARTELS
CHRISTOPHER L. DOUGLAS
ANDRÉ HENRIQUES

Conformal nets are a mathematical model for conformal field theory, and defects between conformal nets are a model for an interaction or phase transition between two conformal field theories. We previously introduced a notion of composition, called *fusion*, between defects. We also described a notion of sectors between defects, modeling an interaction among or transformation between phase transitions, and defined fusion composition operations for sectors. In this paper we prove that altogether the collection of conformal nets, defects, sectors, and intertwiners, equipped with the fusion of defects and fusion of sectors, forms a symmetric monoidal 3-category. This 3-category encodes the algebraic structure of the possible interactions among conformal field theories.

81T05, 18D05

Introduction

Background and results

Conformal nets are a mathematical formalization of the notion of conformal field theory [5, 6, 7, 9, 10, 11, 13]. This paper is the fourth in a series investigating *coordinate-free conformal nets* and their *defects* [1, 2, 3]. The notion of coordinate-free conformal nets is a modification of the usual notion of conformal nets, in which one does not demand the positive-energy condition and does not require the existence of a vacuum vector in the vacuum sector.¹ Here we will use the term ‘conformal net’ to refer to coordinate-free conformal nets.

In the preceding paper [3], we introduced defects between conformal nets and gave examples thereof. (Conjecturally, such defects can also be obtained by taking spatial slices of defects on two-dimensional Minkowski space-time [4].) In this paper, defects

¹We refer to the first paper of the series [1, §4] for a detailed comparison between the usual notion and the coordinate-free notion of conformal nets.

will provide a notion of 1-morphism between conformal nets. Crucially, in [3, Def. 3.1], we introduced the operation of *fusion of defects*, when the conformal nets have finite-index—this fusion will provide the composition operation on 1-morphisms between nets. We defined the associator isomorphism for this fusion operation, and proved it satisfies the pentagon equation. We investigated *sectors between defects*—in what follows these will form the 2-morphisms between 1-morphisms between nets—and introduced the horizontal and vertical fusion of sectors, along with their respective associators. We also constructed the fundamental *interchange isomorphism* relating the vertical and horizontal fusion of sectors. All these structures and more are summarized in the first appendix of that paper [3].

Given all the work done in [3] constructing the notions of higher morphisms between nets and their composition operations, one might imagine that it would be straightforward to establish that finite-index conformal nets, defects, sectors, and intertwiners form a *tricategory*. But unfortunately, tricategories are complicated beasts. This entire paper is, in effect, devoted to the proof of the following theorem:

Theorem 1 *The collections of all finite-index conformal nets, defects, sectors, and intertwiners form the objects, 1-morphisms, 2-morphisms, and 3-morphisms of a tricategory.*

Let CAT denote the 2-category of categories; previously [8], we introduced a notion of tricategory called a *dicategory object in CAT*.² A dicategory object in CAT consists of a category of objects, a category of 1-morphisms, and a category of 2-morphisms, together with various functors encoding identity and composition operations and various natural transformations encoding compatibility relationships between the operations, all satisfying various axioms encoding coherences between the compatibility relationships. We proved in [8] that every dicategory object in CAT has an associated tricategory—Theorem 1 is therefore a corollary of the following result:

Theorem 2 *The groupoid of all finite-index conformal nets, the groupoid of all defects, and the category of all sectors form, respectively, the category of objects, the category of 1-morphisms, and the category of 2-morphisms for a dicategory object in CAT .*

The tensor product of two conformal nets is again a conformal net, the tensor product of two defects is again a defect, and similarly for sectors and for intertwiners. One might therefore naturally conjecture that finite-index conformal nets form not just a

²A dicategory object differs from a bicategory object in that the associativity structures (but not the unital structures) are strict.

tricategory but in fact a *symmetric monoidal tricategory*. A useful feature of the formalism of dicategory objects is that it makes it particularly simple to incorporate the symmetric monoidal structure. Let SMC denote the 2-category of symmetric monoidal categories, strong (as opposed to lax) symmetric monoidal functors, and symmetric monoidal natural transformations. Our approach to Theorem 2 immediately also proves the follow symmetric monoidal strengthening:

Theorem 3 *The symmetric monoidal groupoid of finite-index conformal nets, the symmetric monoidal groupoid of defects, and the symmetric monoidal category of sectors form, respectively, the object of objects, the object of 1-morphisms, and the object of 2-morphisms of a dicategory object in SMC .*

This theorem is one precise formulation (indeed the only one available at present) of the statement that finite-index conformal nets form a symmetric monoidal tricategory: finite-index conformal nets form a dicategory object in SMC , and the notion of dicategory object in SMC may be interpreted as a notion of symmetric monoidal tricategory.

A dicategory in SMC consists of: [0-data] a symmetric monoidal category of objects, a symmetric monoidal category of 1-morphisms, and a symmetric monoidal category of 2-morphisms; [1-data] various symmetric monoidal functors between (fiber products of) these categories, encoding identity and composition operations; [2-data] various symmetric monoidal natural transformations between (products and composites of) these functors, encoding compatibility relationships between the operations; and [3-axioms] various axioms for these transformations, encoding coherences between the compatibility relationships. These pieces of structure are tracked by labels of the form [D0-x], [D1-x], [D2-x], [D3-x], following the same numbering scheme as in [8, Def. 3.3]; in the body of this paper we will abbreviate these labels to [0-x], [1-x], [2-x], [3-x] respectively. For ease of reference, the complete definition of a dicategory object in a 2-category is compiled here in Appendix A, and an abbreviated definition is depicted there in Table 1.

Overview

In our case, the category of objects [D0-0] is the (symmetric monoidal) category CN_0 of finite conformal nets (finite direct sums of irreducible conformal nets with finite-index), together with isomorphisms between them; the category of 1-morphisms [D0-1] is the (symmetric monoidal) category CN_1 of defects (between finite conformal nets),

together with isomorphisms of defects; and the category of 2-morphisms [D0-2] is the (symmetric monoidal) category CN_2 of sectors (between defects between finite conformal nets), together with homomorphism of sectors (also called intertwiners) that cover isomorphisms of defects and of conformal nets; the intertwiners play the role of 3-morphisms in the overall 3-category. These categories of nets, defects, and sectors are discussed in Section 0 below.

The most important operation in the 3-category is the composition of 1-morphisms [D1-2], which here is a (symmetric monoidal) functor

$$\text{CN}_1 \times_{\text{CN}_0} \text{CN}_1 \rightarrow \text{CN}_1$$

given by the fusion of defects:

$$({}_{\mathcal{A}}D_{\mathcal{B}}, {}_{\mathcal{B}}E_{\mathcal{C}}) \mapsto D \otimes_{\mathcal{B}} E.$$

The existence of this fusion operation is proven in [3, Thm 1.44]. The vertical composition of 2-morphisms [D1-4] is a functor

$$\text{CN}_2 \times_{\text{CN}_1} \text{CN}_2 \rightarrow \text{CN}_2,$$

given by the vertical fusion of sectors:

$$({}_D H_E, {}_E K_F) \mapsto H \boxtimes_E K.$$

This operation is defined in [3, Sec 2.C]. Horizontal composition of 2-morphisms is encoded indirectly using the vertical composition of 2-morphisms together with left and right whisker operations [D1-5, D1-6], which are functors

$$\text{CN}_2 \times_{\text{CN}_0} \text{CN}_1 \rightarrow \text{CN}_2,$$

$$\text{CN}_1 \times_{\text{CN}_0} \text{CN}_2 \rightarrow \text{CN}_2.$$

These whisker functors are given by horizontal fusion with a vacuum sector (identity 2-morphism): for instance the right whisker is

$$({}_{(\mathcal{A}(D_1)\mathcal{B})} H_{(\mathcal{A}(D_2)\mathcal{B})}, {}_{\mathcal{B}} E_{\mathcal{C}}) \mapsto H \boxtimes_{\mathcal{B}} H_0(E),$$

where $H_0(E)$ is the vacuum sector of the defect E . These various composition operations, and others, are presented in Section 1.

Compatibility transformations encode various relationships among the composition operations, for instance the associativity of vertical composition of 2-morphisms [D2-3], the interaction of the horizontal whiskering operation and vertical composition [D2-6, D2-7], and the associativity of the horizontal whiskering [D2-9, D2-10, D2-11] and

of the fusion of defects [D2-12]. The most important compatibility transformation is the switch transformation [D2-8], which is a (symmetric monoidal) natural transformation

$$\mathrm{CN}_2 \times_{\mathrm{CN}_0} \mathrm{CN}_2 \xrightarrow{\mathfrak{S}} \mathrm{CN}_2,$$

between the two functors

$$\begin{aligned} \left({}_{(\mathcal{A}(D_1)_B)} H_{(\mathcal{A}(D_2)_B)}, {}_{(B(E_1)_C)} K_{(B(E_2)_C)} \right) &\mapsto (H \boxtimes_B H_0(E_1)) \boxtimes_{(D_2 \otimes_B E_1)} (H_0(D_2) \boxtimes_B K), \\ &\mapsto (H_0(D_1) \boxtimes_B K) \boxtimes_{(D_1 \otimes_B E_2)} (H \boxtimes_B H_0(E_2)). \end{aligned}$$

These and other compatibility transformations are constructed in Section 2.

The compatibility transformations are subject to various coherence axioms, for instance pentagon conditions for vertical composition of 2-morphisms [D3-4], and for horizontal whiskering [D3-15, D3-16] and horizontal fusion of defects [D3-17], along with conditions governing the interaction of vertical associativity with horizontal whiskering [D3-7]. Crucial coherence conditions are the one controlling the interaction of the switch transformation with vertical composition [D3-8], and the ones controlling the interaction of the switch operation with horizontal whiskering [D3-13, D3-14]. These and other conditions are proven in Section 3.

0 Nets, defects, and sectors

[0-0] Conformal nets

By an *interval*, we shall mean a smooth oriented 1-manifold that is diffeomorphic to the standard interval $[0, 1]$. We let INT denote the category whose objects are intervals and whose morphisms are embeddings (not necessarily orientation-preserving and not necessarily boundary preserving). Let VN be the category whose objects are von Neumann algebras, and whose morphisms are \mathbb{C} -linear $*$ -homomorphisms, and \mathbb{C} -linear $*$ -antihomomorphisms. A *net* is a covariant functor

$$\mathcal{A}: \mathrm{INT} \rightarrow \mathrm{VN}$$

taking orientation-preserving embeddings to homomorphisms and orientation-reversing embeddings to antihomomorphisms. It is said to be *isotonic* if the induced maps for embeddings are injective. In this case, given a subinterval $I \subseteq K$, we will often not distinguish between $\mathcal{A}(I)$ and its image in $\mathcal{A}(K)$. A *conformal net* \mathcal{A} is an isotonic net subject to a number of axioms [1, Def 1.1]. Conformal nets form a symmetric monoidal category, whose morphisms are natural transformations and whose tensor product is the tensor product of VN applied objectwise. There is also the operation

of direct sum of conformal nets; it is also defined objectwise. A conformal net \mathcal{A} is said to be *irreducible* if every algebra $\mathcal{A}(I)$ is a factor. A direct sum of finitely many irreducible conformal nets is called *semisimple*. There is a notion of a *finite* semisimple conformal net (direct sum of conformal nets with finite μ -index [11]), defined utilizing the minimal index from subfactor theory [1, Sec 3]. The object category CN_0 of our 3-category CN is the subcategory of the category of conformal nets whose objects are finite semisimple conformal nets and whose morphisms are natural isomorphisms. This subcategory is a symmetric monoidal subcategory [1, Sec 3]. From now on all nets will be finite and semisimple and will be simply referred to as conformal nets.

[0-1] Defects

A *bicolored interval* is an interval I (always oriented), equipped with a covering by two closed, connected, possibly empty subsets $I_\circ, I_\bullet \subset I$ with disjoint interiors, along with a local coordinate in the neighborhood of $I_\circ \cap I_\bullet$. We disallow the cases where I_\circ or I_\bullet consists of a single point. The local coordinate does *not* need to preserve the orientation, but is required to send $(-\varepsilon, 0]$ into I_\circ and $[0, \varepsilon)$ into I_\bullet . If either I_\circ or I_\bullet is empty, then there is no local coordinate specified. An embedding $f: J \hookrightarrow I$ of bicolored intervals is called *color preserving* if $f^{-1}(I_\circ) = J_\circ$ and $f^{-1}(I_\bullet) = J_\bullet$. The bicolored intervals form a category $\text{INT}_{\circ\bullet}$, whose morphisms are the color preserving embeddings that preserve the local coordinate. Let \mathcal{A} and \mathcal{B} be conformal nets. A *defect* from \mathcal{A} to \mathcal{B} is a functor

$$D: \text{INT}_{\circ\bullet} \rightarrow \text{VN}$$

that extends \mathcal{A} and \mathcal{B} in the following sense: if $I = I_\circ$ then $D(I) = \mathcal{A}(I)$; if $I = I_\bullet$ then $D(I) = \mathcal{B}(I)$. Moreover, D is subject to a number of axioms [3, Def 1.7]. We often say D is an \mathcal{A} - \mathcal{B} -defect and write $D = {}_{\mathcal{A}}D_{\mathcal{B}}$. Direct sum and tensor product for defects can be defined objectwise, as for nets. As morphisms between defects we have again natural transformations. Such a natural transformation ${}_{\mathcal{A}}D_{\mathcal{B}} \rightarrow {}_{\mathcal{A}'}D'_{\mathcal{B}'}$ restricts to natural transformations $\mathcal{A} \rightarrow \mathcal{A}'$ and $\mathcal{B} \rightarrow \mathcal{B}'$. The 1-morphism category of our 3-category CN is the symmetric monoidal category CN_1 whose objects are defects between finite semisimple nets, and whose morphisms are natural isomorphisms. There are forgetful source and target functors $s, t: \text{CN}_1 \rightarrow \text{CN}_0$ defined by $s({}_{\mathcal{A}}D_{\mathcal{B}}) = \mathcal{A}$ and $t({}_{\mathcal{A}}D_{\mathcal{B}}) = \mathcal{B}$.

Proposition *The symmetric monoidal functor $s \times t: \text{CN}_1 \rightarrow \text{CN}_0 \times \text{CN}_0$ is a fibration in the sense of [8, Def 2.1, Def 2.2].*

Proof Observe as follows that the underlying (non-monoidal) functor $s \times t$ is a fibration of categories. Given finite semisimple conformal nets \mathcal{A} , \mathcal{B} , \mathcal{A}' , \mathcal{B}' , natural isomorphisms $\phi : \mathcal{A} \rightarrow \mathcal{A}'$ and $\psi : \mathcal{B} \rightarrow \mathcal{B}'$, and a finite semisimple defect ${}_{\mathcal{A}'}\mathcal{D}'_{\mathcal{B}'}$, we must construct a defect ${}_{\mathcal{A}}\mathcal{D}_{\mathcal{B}}$ and a natural isomorphism ${}_{\mathcal{A}}\mathcal{D}_{\mathcal{B}} \rightarrow {}_{\mathcal{A}'}\mathcal{D}'_{\mathcal{B}'}$. We may take $D(I) = \mathcal{A}(I)$ when I is white, $D(I) = \mathcal{B}(I)$ when I is black, and $D(I) = \mathcal{D}'(I)$ when I is genuinely bicolored, together with $D(I \hookrightarrow J) = \mathcal{D}'(I \hookrightarrow J) \circ \phi(I)$ when I is white and J is genuinely bicolored, and $D(I \hookrightarrow J) = \mathcal{D}'(I \hookrightarrow J) \circ \psi(I)$ when I is black and J is genuinely bicolored. The isomorphism $D \rightarrow \mathcal{D}'$ is the identity on genuinely bicolored intervals and is ϕ , respectively ψ on white and black intervals. That $s \times t$ is in fact a fibration of symmetric monoidal categories is similarly straightforward. \square

Throughout this paper we will depend heavily on graphical notation. Defects will often be represented by a picture, thought of as a bicolored interval, as follows:

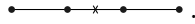

The four bullets on this interval indicate that this interval is of length three. The marked point x denotes the point where the color of the interval changes. We often call this marked point the defect point. Strictly speaking we should include an orientation of our interval, for example from left to right. (Later our intervals will often sit on the boundary of 2-manifolds embedded in the plane. Such a 2-manifold inherits its orientation from the plane and the interval from the boundary of the 2-manifold.) For a defect ${}_{\mathcal{A}}\mathcal{D}_{\mathcal{B}}$ we think of the above interval as representing a collection of von Neumann algebras indexed by subintervals of our interval. If I is a subinterval to the left of x , then it represents the algebra $\mathcal{A}(I) = D(I)$; if I is a subinterval containing x , then it represents $D(I)$; if I is a subinterval to the right of x , then it represents $\mathcal{B}(I) = D(I)$. Sometimes we will simplify our graphical notation and drop the marked point from the interval. If we need coordinates on the above interval, then we will identify it with $[0, 3]$, where 0 corresponds to the left boundary point and 3 to the right boundary point. The defect point then has the coordinate 1.5.

[0-2] Sectors

Consider the standard regular hexagon with side length 1:



In this paper S^1 is *defined* to be the boundary of this hexagon. Sometimes we emphasize this and write S_6^1 for the boundary of this hexagon. Later we will also need the regular

octagon with side length 1; we denote its boundary as S_8^1 . The hexagon inherits an orientation from the plane; this also orients its boundary. We will pick the clockwise orientation of the plane; thus the circle is also clockwise oriented. We think of the above circle as bicolored: the left hand side is white \circ , while the right hand side is black \bullet . The two marked points are the points where the color changes. In particular, every subinterval of S_6^1 that contains at most one of the marked points (and none on the boundary) inherits a bicoloring.

Let ${}_{\mathcal{A}}D_{\mathcal{B}}$ and ${}_{\mathcal{A}}E_{\mathcal{B}}$ be defects. A D - E -sector is a Hilbert space H equipped with actions of algebras represented by the bicolored subintervals of S_6^1 as follows: for every white subinterval $I \subseteq S_6^1$, the algebra $\mathcal{A}(I)$ acts; for every black subinterval $I \subseteq S_6^1$, the algebra $\mathcal{B}(I)$ acts; for every bicolored subinterval containing the upper defect point, the algebra $D(I)$ acts; for every bicolored subinterval containing the lower defect point, the algebra $E(I)$ acts. These actions are subject to compatibility axioms [3, Def 2.2]. We often write $H = {}_D H_E$ to emphasize that H is a D - E sector. For fixed D and E , the D - E -sectors form a category whose morphisms are the bounded linear maps that commute with the actions associated to the bicolored subintervals of S_6^1 . There is also a natural notion of morphism $f: {}_D H_E \rightarrow {}_{D'} H'_{E'}$. In this case f includes morphisms $\mathcal{A} \rightarrow \mathcal{A}'$, $\mathcal{B} \rightarrow \mathcal{B}'$, ${}_{\mathcal{A}}D_{\mathcal{B}} \rightarrow {}_{\mathcal{A}'}D'_{\mathcal{B}'}$, ${}_{\mathcal{A}}E_{\mathcal{B}} \rightarrow {}_{\mathcal{A}'}E'_{\mathcal{B}'}$ and an operator $T: H \rightarrow H'$ that commutes with the induced maps $D(I) \rightarrow D'(I)$ and $E(I) \rightarrow E'(I)$. The tensor product of Hilbert space yields a symmetric monoidal structure on sectors. Thus we obtain the symmetric monoidal category CN_2 of sectors [3, Def 2.7]. This is the 2-morphism category of our 3-category CN .

In the graphical notation we think of a sector ${}_D H_E$ as represented by the above hexagon. We then think of the upper defect point as the D point and the lower defect point as the E point. By definition every bicolored subinterval of S_6^1 corresponds then to a von Neumann algebra that acts on the sector H . (Later, other 2-manifolds will also be thought of as representing certain sectors.) Often we will drop the marked points from the picture. Moreover, we will often draw the hexagon in a rectilinear fashion, for example as one of the following:

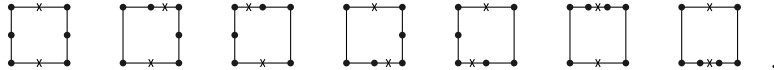

Despite their appearance, all these pictures refer to *the* standard regular hexagon with its two marked points as drawn.

Later it will sometimes be convenient to have coordinates on S_6^1 and S_8^1 . Then we will identify $S^1 \cong \mathbb{R}/6\mathbb{Z}$ such that the coordinates of the corner points are $0, 1, \dots, 5$, where we start on the left and proceed clockwise from there. The coordinate of the upper

defect point is then 1.5, and the coordinate of the lower defect point is $-1.5 \equiv 4.5$. In a similar fashion we will identify S_8^1 with $\mathbb{R}/8\mathbb{Z}$.

Proposition *The symmetric monoidal functor $s \times t: \text{CN}_2 \rightarrow \text{CN}_1 \times_{\text{CN}_0 \times \text{CN}_0} \text{CN}_1$ is a fibration in the sense of [8, Def 2.1, Def 2.2].*

Proof Observe as follows that the underlying (non-monoidal) functor $s \times t$ is a fibration of categories. Given finite semisimple conformal nets $\mathcal{A}, \mathcal{B}, \mathcal{A}', \mathcal{B}'$, finite semisimple defects ${}_{\mathcal{A}}D_{\mathcal{B}}, {}_{\mathcal{A}}E_{\mathcal{B}}, {}_{\mathcal{A}'}D'_{\mathcal{B}'}, {}_{\mathcal{A}'}E'_{\mathcal{B}'}$, natural isomorphisms $\phi: D \rightarrow D'$ and $\psi: E \rightarrow E'$, and a sector ${}_{D'}H'_{E'}$, we must construct a sector ${}_D H_E$ and an isomorphism ${}_D H_E \rightarrow {}_{D'} H'_{E'}$. We may take the Hilbert space H to be H' , together with $d \in D(I)$ acting by $\phi(d) \in D'(I)$ when I does not contain the lower defect point and with $e \in E(I)$ acting by $\psi(e) \in E'(I)$ when I does not contain the upper defect point. The isomorphism ${}_D H_E \rightarrow {}_{D'} H'_{E'}$ is the identity on the Hilbert space, and is ϕ and ψ on D and E respectively. That $s \times t$ is in fact a fibration of symmetric monoidal categories is similarly straightforward. \square

Implementation of diffeomorphisms

Let \mathcal{A} be a net, I an interval, and $\varphi: I \rightarrow I$ a diffeomorphism that is the identity in a neighborhood of the boundary of I . To this diffeomorphism, there is an associated automorphism $\mathcal{A}(\varphi)$ of $\mathcal{A}(I)$, and it is one of the requirements for conformal nets that this automorphism is inner: there is a unitary $U_\varphi \in \mathcal{A}(I)$ such that $\mathcal{A}(\varphi)(a) = U_\varphi a U_\varphi^*$. We then say that U_φ implements φ on $\mathcal{A}(I)$. Of course, U_φ is not unique. If $\alpha: \mathcal{A} \rightarrow \mathcal{B}$ is a morphism of CN_0 , then $\alpha(I)(U_\varphi)$ is an implementation of φ on $\mathcal{B}(I)$.

Let ${}_{\mathcal{A}}D_{\mathcal{B}}$ and ${}_{\mathcal{A}}E_{\mathcal{B}}$ be defects and let ${}_D H_E$ be a sector. Let $\varphi: S_6^1 \rightarrow S_6^1$ be a diffeomorphism that fixes a neighborhood of both defect points. We can then pick subintervals I_L of the left half of S_6^1 and I_R of the right half of the circle S_6^1 such that φ is the identity on a neighborhood of the complement of $I_L \cup I_R$. In particular, φ restricts to diffeomorphisms φ_L and φ_R of I_L and I_R . We obtain automorphisms $\mathcal{A}(\varphi_L)$ of $\mathcal{A}(I_L)$ and $\mathcal{B}(\varphi_R)$ of $\mathcal{B}(I_R)$. A unitary $U: H \rightarrow H$ is said to *implement* φ if

$$\mathcal{A}(\varphi_L)(a) \circ U = U \circ a \quad \text{and} \quad \mathcal{B}(\varphi_R)(b) \circ U = U \circ b$$

as operators on H for all $a \in \mathcal{A}(I_L)$, $b \in \mathcal{B}(I_R)$. Such an implementation always exists; for example we can set $U := U_L \circ U_R$ where U_L implements φ_L on $\mathcal{A}(I_L)$ and U_R implements φ_R on $\mathcal{B}(I_R)$. (It is part of the axioms for sectors that the actions of $\mathcal{A}(I_L)$ and $\mathcal{B}(I_R)$ on H commute; in particular U_L is $\mathcal{B}(I_R)$ -linear and U_R is $\mathcal{A}(I_L)$ -linear.)

1 Composition and identity operations

1.A Horizontal identity and composition

[1-1] Horizontal identity.

Let $\mathcal{A}: \text{INT} \rightarrow \text{VN}$ be a conformal net. Then the identity defect $\text{id}_{\mathcal{A}}$ for \mathcal{A} is defined by

$$\text{id}_{\mathcal{A}} = \mathcal{A} \circ \text{forget}$$

where $\text{forget}: \text{INT}_{\bullet} \rightarrow \text{INT}$ is the functor that forgets the bicoloring. The 1-cell identity $\text{CN}_0 \rightarrow \text{CN}_1$ is defined to be the functor $\mathcal{A} \mapsto \text{id}_{\mathcal{A}}$. We will draw the identity defect as

$$\bullet \text{---} \bullet \text{=} \bullet \text{---} \bullet \quad [1-1]$$

where we use an equal sign (rotated) in the place of the usual x at the defect point. Sometimes we simplify this by dropping the defect marker altogether:

$$\bullet \text{---} \bullet \text{---} \bullet \text{---} \bullet \quad .$$

[1-2] Horizontal composition.

The horizontal composition is defined as the horizontal composition of defects as introduced in [3, Sec 1.E]. We write this horizontal composition functor $\text{CN}_1 \times_{\text{CN}_0} \text{CN}_1 \rightarrow \text{CN}_1$ as $(\mathcal{A}D_{\mathcal{B}}, \mathcal{B}E_{\mathcal{C}}) \mapsto D \otimes_{\mathcal{B}} E$ and draw the composite of two defects as

$$\bullet \text{---} \bullet \text{*} \bullet \text{*} \bullet \text{---} \bullet \quad [1-2].$$

Here the left defect point is associated to D and the right defect point is associated to E . We will review horizontal composition of defects and explain the picture in more detail below in Section 1.C.

1.B Vertical identity and composition

[1-3] Vertical identity.

Let $D = \mathcal{A}D_{\mathcal{B}}$ be a defect, and let S be a circle with a bicoloring-preserving automorphism that exchanges the two color change points—we refer to such an automorphism as a reflection. The vacuum sector $H_0(D, S) = {}_D H_0(D, S)_D$ of D on S was introduced in [3, Sec 1.B]. If S is the standard circle S_6^1 , then the reflection along the horizontal

axis is a canonical choice of a bicoloring-preserving reflection. (In coordinates the reflection is $t \mapsto 6 - t$). We call $H_0(D) := H_0(D, S_6^1)$ the vacuum sector of D . The functor $D \mapsto H_0(D)$ defines the 2-cell identity $\text{CN}_1 \rightarrow \text{CN}_2$. The underlying Hilbert space of the vacuum sector is the standard form $L^2(D(I))$ of the von Neumann algebra $D(I)$, where I is the upper half of the circle S_6^1 . (This is also the interval of length 3 used earlier.) Pictorially we denote the vacuum sector as



In this picture, the gray shading indicates that the sector is a vacuum sector; an arbitrary sector would have no interior shading. The upper and the lower half of S_6^1 are both copies of our bicolored interval I and correspond to the two actions of $D(I)$ on $L^2(D(I))$. Sometimes we will drop the defect points from our pictures. Moreover, we might draw the picture in a rectilinear fashion such as

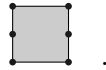

We point out that whenever the boundary of the circle is split into two intervals each of which contains a defect point in the interior, then the corresponding algebras are commutants of each other [3, Prop 1.16].

[1-4] Vertical composition.

The vertical composition $\text{CN}_2 \times_{\text{CN}_1} \text{CN}_2 \rightarrow \text{CN}_2$ is defined as the vertical fusion from [3, Sec 2.C]. Our picture for the vertical fusion is



Note that the boundary of this picture is canonically S_6^1 . In particular, no boundary reparametrisation is needed in the definition of vertical fusion. Often the picture is simplified by omitting defect points and is drawn as a rectilinear equivalent

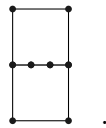

The underlying Hilbert space of the vertical fusion of sectors is the Connes fusion of the Hilbert spaces for the two sectors over the algebra associated to the horizontal interval

of length 3 in the middle of the pictures. Sometimes will will draw this pictures in the following different, but equivalent, forms



These versions will be helpful when we discuss the vertical fusion of three sectors.

1.C Horizontal whiskers

Horizontal fusion.

The definition of a 3-category that we are using in this paper does not (for reasons of efficiency) directly include a notion of horizontal composition of 2-morphisms. Nevertheless, there is such a composition for our sectors called *horizontal fusion* of sectors and this operation will be the basis for many pieces of structure in our 3-category. Horizontal fusion is a functor $\text{CN}_2 \times_{\text{CN}_0} \text{CN}_2 \rightarrow \text{CN}_2$ and is defined in [3, Sec 2.B]. In symbols, given defects ${}_{\mathcal{A}}(D_1)_{\mathcal{B}}$, ${}_{\mathcal{A}}(D_2)_{\mathcal{B}}$, ${}_{\mathcal{B}}(E_1)_{\mathcal{C}}$, and ${}_{\mathcal{B}}(E_2)_{\mathcal{C}}$, we will write the horizontal fusion functor as

$$({}_{D_1}H_{D_2, E_1}K_{E_2}) \mapsto ({}_{D_1 \otimes_{\mathcal{B}} E_1}(H \boxtimes_{\mathcal{B}} K)_{D_2 \otimes_{\mathcal{B}} E_2}).$$

We draw $H \boxtimes_{\mathcal{B}} K$ as

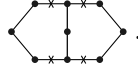

The underlying Hilbert space is the Connes fusion of H and K along the algebra associated by \mathcal{B} to the vertical interval I of length 2 in the middle of the picture. Note that I inherits two different orientations from the two (deformed) hexagons. If we orient I using the right hexagon (corresponding to K), then $\mathcal{B}(I)$ acts on K , while $\mathcal{B}(-I) = \mathcal{B}(I)^{\text{op}}$ acts on H . It is exactly this situation that allows the use of Connes fusion (just as one may take the tensor product of a right module and a left module). Sometimes we drop defect points from the picture. Moreover, we often draw a rectilinear version of the picture,

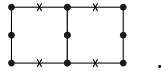

We can now give a brief summary of the composition of defects. Let ${}_{\mathcal{A}}D_{\mathcal{B}}$ and ${}_{\mathcal{B}}E_{\mathcal{C}}$ be defects. Consider $H_0(D) \boxtimes_{\mathcal{B}} H_0(E)$, the horizontal composition of the vacuum sectors for D and E ,

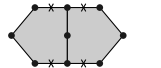

The boundary of this picture is drawn as an irregular hexagon, but its boundary has length 8. Thus it can be identified with the octagon S_8^1 , and the upper four segments of the boundary can be identified with the interval I_4 of length 4

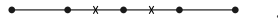

The evaluation of the composed defect $D \otimes_{\mathcal{B}} E$ on this interval is generated in the algebra of bounded operators on $H_0(D) \boxtimes_{\mathcal{B}} H_0(E)$ by the evaluation of D on the first two segments and by the evaluation of E on the last two segments. Similarly, we obtain an algebra acting on $H_0(D) \boxtimes_{\mathcal{B}} H_0(E)$ for any subinterval of I_4 . The interval I_4 is not bicolored, but there is a map onto a bicolored interval I_3 of length 3 that collapses the two half segments between the two defect points to a single defect point, and this collapse map is used to view $D \otimes_{\mathcal{B}} E$ as a functor on $\text{INT}_{\circ\bullet}$. The evaluation of $D \otimes_{\mathcal{B}} E$ on a subinterval of I_3 is defined via its preimage in I_4 under the collapse map. In our pictures we never indicate this collapse map in any way. Thus the pictures remember more than just the structure of $D \otimes_{\mathcal{B}} E$ as a defect: we see more subintervals to which we can associate algebras, for example we could consider a little neighborhood of the left (say) defect point. In a similar fashion our picture for the horizontal fusion remembers more than just the structure of a sector; it also encodes the actions of some additional algebras. If we compose more than two defects, then we obtain intervals of yet longer length with yet more defect points.

To formally define the horizontal fusion of sectors a similar collapse map $\pi: S_8^1 \rightarrow S_6^1$ is used. It collapses four half segments to two points. On the upper half this is just the collapse map used before, on the lower half this is the reflection of that collapse map.

[1-5] Right whisker.

The right composition of a 1-cell with a 2-cell $\text{CN}_2 \times_{\text{CN}_0} \text{CN}_1 \rightarrow \text{CN}_2$ is defined using horizontal fusion and the vacuum sector. Let \mathcal{A} , \mathcal{B} , and \mathcal{C} be nets, let ${}_{\mathcal{A}}(D_1)_{\mathcal{B}}$, ${}_{\mathcal{A}}(D_2)_{\mathcal{B}}$, and ${}_{\mathcal{B}}E_{\mathcal{C}}$ be defects, and let ${}_{D_1}H_{D_2}$ be a sector. The right composition of H with E is defined as the horizontal fusion $H \boxtimes_{\mathcal{B}} H_0(E)$. We draw this as



Again, often this is drawn as

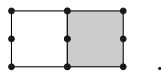

Here we omitted defect points from the pictures, but sometimes we will include them for clarity.

[1-6] Left whisker.

The left composition of a 1-cell with a 2-cell is defined similarly to the right composition, and is drawn as

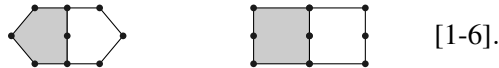

The data discussed so far is part of the definition of both a 2-category object and a dicategory object (in the 2-category of symmetric monoidal categories). We remind the reader that our 3-category of conformal nets is a dicategory object; the next two pieces of data labeled here [1-7] and [1-8] are labeled [D1-7] and [D1-8] in the appendix and correspondingly in [8].

1.D Directional identity cells

[1-7] Left identity.

The (upper) left 2-cell identity is a functor $\text{CN}_1 \rightarrow \text{CN}_2$. Its role is to show that the composition of a defect with an identity defect is, at least in a weak sense, equivalent to the original defect.

Let ${}_{\mathcal{A}}D_{\mathcal{B}}$ be a defect. There is no canonical isomorphism between $\text{id}_{\mathcal{A}} \otimes_{\mathcal{A}} D$ and D in CN_1 . (For this reason our 3-category of conformal nets is not a 2-category object in symmetric monoidal categories.) There is however a canonical $(\text{id}_{\mathcal{A}} \otimes_{\mathcal{A}} D)$ - D -sector, the left identity for D . Our picture of this left identity is

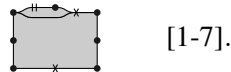

This sector is the vacuum sector $H_0(D)$ for D (this is the box part of the picture), twisted by a diffeomorphism (indicated by the balloon in the picture). Details of this construction follow.

We begin by reviewing the defect $\text{id}_{\mathcal{A}} \otimes_{\mathcal{A}} D$. Consider the collapse map $\pi: S_8^1 \rightarrow S_6^1$ used earlier. This map is symmetric with respect to the reflection along the horizontal axis (in coordinates the reflection is given by $x \mapsto -x$). The restriction of π to the upper half of S_8^1 is a map $I_4 \rightarrow I_3$, which collapses $[1.5, 2.5] \subset I_4$ to $1.5 \in I_3$, sends $x \in [0, 1.5] \subset I_4$ to $x \in [0, 1.5]$, and sends $x \in [2.5, 4] \subset I_4$ to $x - 1 \in [1.5, 3] \subset I_3$. The evaluation of $\text{id}_{\mathcal{A}} \otimes_{\mathcal{A}} D$ on a bicolored subinterval I of I_3 is the algebra $D(\pi^{-1}(I))$.

(This algebra is isomorphic to $D(I)$, but there is no canonical isomorphism if I contains the upper defect point 1.5.)

To construct the left identity we pick a diffeomorphism $\Phi_L: S_8^1 \rightarrow S_6^1$ such that $\Phi_L(x) = x$ on a neighborhood of $[0, 1]$ and $\Phi_L(x) = x - 1$ on a neighborhood of $[2.5, 4]$ and is symmetric with respect to the vertical reflection of the circles; that is, we require that $\Phi_L(-x) = -\Phi_L(x)$. In particular, Φ_L coincides with π on $[0, 1] \cup [2.5, 4]$. Now we start with the vacuum sector $H_0(D)$ for D :

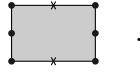

It is a D - D -sector. We can twist the upper D -action by the restriction of Φ_L to the upper half I_3 of S_6^1 , turning $H_0(D)$ into an $(\text{id}_A \otimes_A D)$ - D -sector. More precisely, if $I \subseteq S_6^1$ is a bicolored interval containing the upper defect point, then the action of $(\text{id}_A \otimes_A D)(I)$ on $H_0(D)$ is defined via the isomorphism

$$(\text{id}_A \otimes_A D)(I) = D(\pi^{-1}(I)) \xrightarrow{D(\Phi_L|_{\pi^{-1}(I)})} D(\Phi_L(\pi^{-1}(I))).$$

Because $\Phi_L(x) = x$ on a neighborhood of $[0, 1]$ and $\Phi_L(x) = x - 1$ on a neighborhood of $[2.5, 4]$ it follows that this construction indeed defines a sector. We define the left identity for D to be this sector. (The left identity functor $\text{CN}_1 \rightarrow \text{CN}_2$ constructed in this section, and similarly the right identity functor in the next section, depends on the choice of the diffeomorphism Φ_L . However, as discussed in the later Remark 7, distinct choices here will result in isomorphic 3-categories.)

The small balloon in the above picture represents the restriction of Φ_L to $[1, 2.5] \rightarrow [1, 1.5]$. Occasionally we use the abbreviated notation



or



in which a small vertical tick indicates that the top is a composition of two defects, or, when there could be no confusion, simply by



[1-8] Right identity.

The right identity is defined similarly to the left identity; specifically the right identity is a horizontal reflection of the left identity. Thus we replace the diffeomorphism Φ_L by the diffeomorphism $\Phi_R: S_8^1 \rightarrow S_6^1$, $\Phi_R(x) := 3 - \Phi_L(4 - x)$. The pictures for the right identity are:

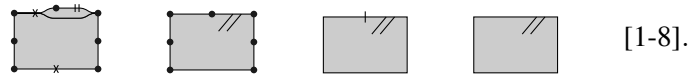

Lemma *The left and the right identity sectors are invertible with respect to vertical fusion of sectors, as required in the definition of a dicategory object.*

Proof An inverse for the left identity is given by a vertical reflection of the left identity. Similarly, an inverse for the right identity is given by a vertical reflection of the right identity. □

The procedure of twisting with a diffeomorphism as in the construction of the left identity [1-7] can be applied to other defects than the vacuum sector. We can twist any ${}_{\mathcal{A}}D_{\mathcal{B}}$ - ${}_{\mathcal{A}}E_{\mathcal{B}}$ -sector by a diffeomorphism to obtain an $(\text{id}_{\mathcal{A}} \otimes_{\mathcal{A}} D)$ - E -sector. Varying the position of the diffeomorphism we can also produce a $(D \otimes_{\mathcal{B}} \text{id}_{\mathcal{B}})$ - E -sector or a D - $(\text{id}_{\mathcal{A}} \otimes_{\mathcal{A}} E)$ -sector or a D - $(E \otimes_{\mathcal{B}} \text{id}_{\mathcal{B}})$ -sector. Moreover this process can be reversed. For example given a $(\text{id}_{\mathcal{A}} \otimes_{\mathcal{A}} D)$ - E -sector we can twist by the inverse of Φ_L to obtain a D - E -sector. These constructions are inverse to each other. Also note that in vertical compositions we will often move the diffeomorphism from one sector to another, when this does not affect the resulting composite sector; for example the following pictures are interchangeable:

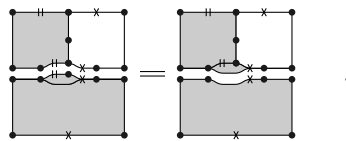

2 Compatibility transformations for composition and identity operations

2.A Transformations for vertical identity and composition

[2-1] Top identity

There is a canonical natural isomorphism

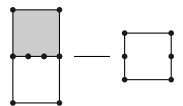
[2-1]

because the underlying Hilbert space of the identity defect on the left hand side is the standard form of the algebra associated to the interval of length 3 in the middle of the picture on the left hand side. (Here we have denoted the isomorphism between the left and right Hilbert spaces simply as a horizontal dash, without an arrowhead, to indicate that the morphism may be read in either direction.) This is the top identity.

[2-2] Bottom identity

The bottom identity is similarly depicted

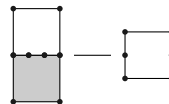

[2-2].

[2-3] Vertical associator

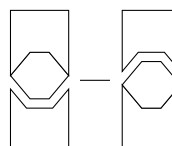
Connes fusion of bimodules over von Neumann algebras is not strictly associative, but there is a coherent associator for this operation (similar to the associator for the algebraic tensor product of bimodules over rings). Because vertical fusion is defined using fusion along the algebra corresponding to the upper, respectively lower, half of our standard circle, the associator for Connes fusion over von Neumann algebras is also an associator for vertical fusion of sectors. We will draw this associator as

[2-3].

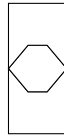
The little gap on the left hand side illustrates that here we first do the Connes fusion along the upper algebra; on the right hand side the gap illustrates that we first do the Connes fusion along the lower algebra. Because this associator just comes from the fact that Connes fusion over von Neumann algebras is not strictly associative we will henceforth very often suppress this isomorphism and treat the right hand and left hand side of the above picture as equal; we therefore simply draw this vertical fusion as



2.B Transformations for horizontal composition and whiskers

1 \boxtimes 1-isomorphism

Crucial for the construction of our 3-category is the 1 \boxtimes 1-isomorphism from [3, Thm 6.2]. The 1 \boxtimes 1-isomorphism provides a natural isomorphism between two functors $\text{CN}_1 \times_{\text{CN}_0} \text{CN}_1 \rightarrow \text{CN}_2$ defined as follows. Let ${}_{\mathcal{A}}D_{\mathcal{B}}$ and ${}_{\mathcal{B}}E_{\mathcal{C}}$ be defects. The first functor sends (D, E) to $H_0(D) \boxtimes_{\mathcal{B}} H_0(E)$ and the second functor sends (D, E) to $H_0(D \otimes_{\mathcal{B}} E)$. Thus the 1 \boxtimes 1 isomorphism shows in particular that the horizontal fusion of two vacuum sectors is again a vacuum sector. In pictures the 1 \boxtimes 1-isomorphism is denoted

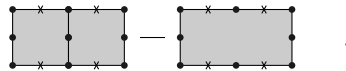

[2-4] and [2-5] Right and left vertical identity expansion.

The right and left vertical identity expansions coincide and are both given by the 1 \boxtimes 1-isomorphism. In pictures we have

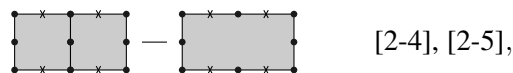

but often we will drop the defect points from the notation.

The categories $\text{CN}_{\sim 2}$, $\text{CN}^{\sim 2}$ and $\text{CN}_{\sim 2}^{\sim}$.

We will later need variants of CN_2 that have more morphisms.

The following notation will be helpful. If $\varphi: A \rightarrow B$ is a map of von Neumann algebras, H is an A -module, and K is a B -module, then we denote by $\text{Hom}_\varphi(H, K)$ the space of all bounded linear maps $T: H \rightarrow K$ that are φ -linear, that is such that for all $a \in A$ and $\xi \in H$ we have $T(a\xi) = \varphi(a)T(\xi)$.

We start by recalling the precise definition of the morphisms in CN_2 . For defects ${}_{\mathcal{A}}D_{\mathcal{B}}$, ${}_{\mathcal{A}}E_{\mathcal{B}}$, ${}_{\mathcal{A}'}D'_{\mathcal{B}'}$, and ${}_{\mathcal{A}'}E'_{\mathcal{B}'}$, and sectors ${}_D H_E$ and ${}_{D'} H'_{E'}$ a morphism $f: {}_D H_E \rightarrow {}_{D'} H'_{E'}$ is a triple $f = (T, \delta, \varepsilon)$ where $T: H \rightarrow H'$ is a bounded linear map and $\delta: D \rightarrow D'$ and $\varepsilon: E \rightarrow E'$ are morphisms from CN_1 such that $s(\delta) = s(\varepsilon): \mathcal{A} \rightarrow \mathcal{A}'$ and $t(\delta) = t(\varepsilon): \mathcal{B} \rightarrow \mathcal{B}'$. Moreover, T is required to be $\delta(I)$ -linear for all bicolored subintervals I of S_6^1 not containing the lower defect point, and to be $\varepsilon(I)$ -linear for all bicolored subintervals not containing the upper defect points. (On subintervals not containing a defect point these two requirements coincide.)

Informally, the categories $\text{CN}_{\sim 2}$, $\text{CN}^{\sim 2}$, $\text{CN}_{\sim 2}^{\sim}$ are obtained, respectively, by relaxing the linearity of morphisms around the lower defect point (for $\text{CN}_{\sim 2}$), around the upper defect point (for $\text{CN}^{\sim 2}$), or around both defect points (for $\text{CN}_{\sim 2}^{\sim}$). In all three cases the objects coincide with the objects of CN_2 . Morphisms are defined more formally as follows. We use the following subintervals of our standard circle S_6^1 :

$$I_{\sim} := [4, 5], I_{\sim}^c := [-1, 4], I^{\sim} := [1, 2], I^{\sim c} := [2, 7], I_l := [-1, 1], I_r := [2, 4].$$

Let ${}_{\mathcal{A}}D_{\mathcal{B}}$, ${}_{\mathcal{A}}E_{\mathcal{B}}$, ${}_{\mathcal{A}'}D'_{\mathcal{B}'}$, and ${}_{\mathcal{A}'}E'_{\mathcal{B}'}$ be defects and let ${}_D H_E$ and ${}_{D'} H'_{E'}$ be sectors. A morphism $f: H \rightarrow H'$ in $\text{CN}_{\sim 2}$ is a pair $f = (T, \varepsilon)$ where $\varepsilon: E \rightarrow E'$ is a morphism of CN_1 and $T \in \text{Hom}_{\varepsilon(I_{\sim}^c)}(H, H')$. A morphism $f: H \rightarrow H'$ in $\text{CN}^{\sim 2}$ is a pair $f = (T, \delta)$ where $\delta: D \rightarrow D'$ is a morphism of CN_1 and $T \in \text{Hom}_{\delta(I_{\sim}^c)}(H, H')$. Finally, a morphism $f: H \rightarrow H'$ in $\text{CN}_{\sim 2}^{\sim}$ is a triple $f = (T, \alpha, \beta)$ where $\alpha: \mathcal{A} \rightarrow \mathcal{A}'$, $\beta: \mathcal{B} \rightarrow \mathcal{B}'$ are morphisms of CN_0 and $T: H \rightarrow H'$ belongs to both $\text{Hom}_{\alpha(I_l)}(H, H')$ and $\text{Hom}_{\beta(I_r)}(H, H')$. Note that there are forgetful functors $\text{CN}^{\sim 2} \rightarrow \text{CN}_{\sim 2}$ and $\text{CN}_{\sim 2} \rightarrow \text{CN}_{\sim 2}^{\sim}$ that are the identity on objects and for morphisms are defined by $(T, \varepsilon) \mapsto (T, s(\varepsilon), t(\varepsilon))$ and $(T, \delta) \mapsto (T, s(\delta), t(\delta))$.

We remark that many of our previous constructions extend to these variants of CN_2 . For example the vertical fusion [1-4] is natural for these more general morphisms and thus extends canonically to a functor $\text{CN}_{\sim 2}^{\sim} \times_{\text{CN}_1} \text{CN}_{\sim 2} \rightarrow \text{CN}_{\sim 2}^{\sim}$. As a rule of thumb: whenever we have a neighborhood of a defect point on the boundary of the picture describing one of our functors, we can canonically extend that functor, adding an appropriate \sim to source and target of the functor.

Homomorphisms in CN^{\sim}_2 (or $\text{CN}_{\sim 2}$) between vacuum sectors can be more concretely described, as follows:

Lemma 4 *Let ${}_{\mathcal{A}}D_{\mathcal{B}}$, ${}_{\mathcal{A}'}D'_{\mathcal{B}'}$ be defects, and let $\delta: D \rightarrow D'$ be an (iso)morphism of defects. Then there is an isomorphism of vector spaces from $D'(I^{\sim})$ to $\text{Hom}_{\delta(I^{\sim c})}(H_0(D), H_0(D'))$ given by $b \mapsto b \circ H_0(\delta)$. Here we use “ b ” to refer both to an algebra element and to the linear map given by multiplying by that element.*

In particular, if we view $H_0(D)$ and $H_0(D')$ as objects of CN^{\sim}_2 , then given a bounded linear map $F: H_0(D) \rightarrow H_0(D')$, the pair $f := (F, \delta)$ defines a morphism $H_0(D) \rightarrow H_0(D')$ in CN^{\sim}_2 if and only if $F = b \circ H_0(\delta)$ for some $b \in D'(I^{\sim})$.

Proof Haag duality for defects [3, Prop 1.16] implies that $\text{Hom}_{D'(I^{\sim c})}(H_0(D'), H_0(D')) = D'(I^{\sim})$, i.e., every $D'(I^{\sim c})$ -linear operator on $H_0(D')$ is given by the action of a unique element in $D'(I^{\sim})$.

Now $H_0(\delta): H_0(D) \rightarrow H_0(D')$ is a $\delta(K)$ -linear isomorphism for all intervals $K \subseteq S_6^1$. In particular it is $\delta(I^{\sim c})$ -linear and induces an isomorphism

$$D'(I^{\sim}) = \text{Hom}_{D'(I^{\sim c})}(H_0(D'), H_0(D')) \rightarrow \text{Hom}_{\delta(I^{\sim c})}(H_0(D), H_0(D')).$$

The second statement follows from the first and the definition of CN^{\sim}_2 . □

The categories CN^{\sim}_2 and $\text{CN}_{\sim 2}$.

We define CN^{\sim}_2 as the full subcategory of CN^{\sim}_2 on objects of the form $H_0(D) \otimes \ell$, where ${}_{\mathcal{A}}D_{\mathcal{B}}$ is a defect and ℓ is a separable Hilbert space. It is a monoidal subcategory. Similarly we obtain a monoidal subcategory $\text{CN}_{\sim 2}$ of $\text{CN}_{\sim 2}$.

Proposition 5 *Every object from CN_2 is isomorphic in CN^{\sim}_2 (resp. in $\text{CN}_{\sim 2}$) to a direct summand of an object from CN^{\sim}_2 (resp. from $\text{CN}_{\sim 2}$).*

Proof Let ${}_{\mathcal{A}}D_{\mathcal{B}}$, ${}_{\mathcal{A}'}E_{\mathcal{B}'}$ be defects and let ${}_{D'}K_E$ be a sector (in other words, an object of CN_2). In particular, K is an $E(I)$ -module, where $I = [2, 7]$ is the complement of the interval $(1, 2)$ of our standard circle S_6^1 . Observe that the vacuum sector $H_0(E)$ is faithful as an $E(I)$ -module (in fact $H_0(E)$ is isomorphic to the standard form $L^2(E(I))$). Recall that whenever A is a separable von Neumann algebra acting on a separable Hilbert space H and acting faithfully on a separable Hilbert space H' , then there is an A -linear isometric embedding $H \otimes \ell \rightarrow H' \otimes \ell$, and in particular an isometric embedding

$H \rightarrow H' \otimes \ell$, where ℓ is an infinite-dimensional Hilbert space. We can therefore find an $E(I)$ -linear isometric embedding of K into $H_0(E) \otimes \ell$ for some separable Hilbert space ℓ . By the definition of CN^{\sim}_2 this embedding defines a morphism $K \rightarrow H_0(E) \otimes \ell$ in CN^{\sim}_2 , as desired. \square

Proposition 6 *Let ${}_{\mathcal{A}}D_{\mathcal{B}}$ and ${}_{\mathcal{A}'}D'_{\mathcal{B}'}$ be defects and let ℓ and ℓ' be separable Hilbert spaces. Consider $X := H_0(D) \otimes \ell$ and $X' := H_0(D') \otimes \ell'$ as objects of CN^{\sim}_2 . Let $f = (\tilde{F}, \delta): X \rightarrow X'$ be a morphism in CN^{\sim}_2 . Let $Y := H_0(D') \otimes \ell$. Then f can be factored through Y as $f = f_2 \circ f_1$ in CN^{\sim}_2 where f_1 is induced by δ and f_2 is the identity on D' . More precisely we have*

- (i) $f_1 = (H_0(\delta) \otimes \text{id}_{\ell}, \delta): X \rightarrow Y$;
- (ii) $f_2 = (T, \text{id}_{D'}): Y \rightarrow X'$ where $T \in D'(I) \otimes \mathbf{B}(\ell, \ell')$, with $I = [1, 2]$.

Here, the space $\mathbf{B}(\ell, \ell')$ of bounded linear maps $\ell \rightarrow \ell'$ is a corner in the von Neumann algebra $\mathbf{B}(\ell \oplus \ell')$, and the tensor product $D'(I) \otimes \mathbf{B}(\ell, \ell')$ is defined to be the closure of the corresponding algebraic tensor product in the von Neumann algebra $D'(I) \otimes \mathbf{B}(\ell \oplus \ell')$.

Proof of Proposition 6 We have to find $T \in D'(I^{\sim}) \otimes \mathbf{B}(\ell, \ell')$ such that $\tilde{F} = T \circ (H_0(\delta) \otimes \text{id}_{\ell})$.

By the definition of CN^{\sim}_2 we have

$$\tilde{F} \in \text{Hom}_{\delta(I^{\sim}c)}(H_0(D) \otimes \ell, H_0(D') \otimes \ell') \cong \text{Hom}_{\delta(I^{\sim}c)}(H_0(D), H_0(D')) \otimes \mathbf{B}(\ell, \ell').$$

By Lemma 4, the map $T_0 \mapsto T_0 \circ H_0(\delta)$ gives an isomorphism

$$D'(I^{\sim}) \cong \text{Hom}_{\delta(I^{\sim}c)}(H_0(D), H_0(D')).$$

Therefore $T' \mapsto \tilde{T} \circ (H_0(\delta) \otimes \text{id}_{\ell})$ yields an isomorphism

$$D'(I^{\sim}) \otimes \mathbf{B}(\ell, \ell') \xrightarrow{\cong} \text{Hom}_{\delta(I^{\sim}c)}(H_0(D) \otimes \ell, H_0(D') \otimes \ell').$$

The inverse image of \tilde{F} under this isomorphism provides the desired factorization. \square

[2-6] Right dewhisiker.

The right dewhisiker is an isomorphism

[2-6].

The left and right sides of the above picture describe functors

$$L, R: (\text{CN}_2 \times_{\text{CN}_1} \text{CN}_2) \times_{\text{CN}_0} \times \text{CN}_1 \rightarrow \text{CN}_2$$

and the right dewhisiker is a natural isomorphism $\tau: L \rightarrow R$. Its construction will be a bit involved. We will show that in order to construct τ it suffices to define τ on the image of the functor $I: \text{CN}_1 \times_{\text{CN}_0} \text{CN}_1 \rightarrow (\text{CN}_2 \times_{\text{CN}_1} \text{CN}_2) \times_{\text{CN}_0} \times \text{CN}_1$ defined by $I(\mathcal{A}D\mathcal{B}, \mathcal{B}E\mathcal{C}) = (H_0(D), H_0(D), E)$. Here the natural isomorphism $\tau_0: L \circ I \rightarrow R \circ I$ can be constructed as the following composition:

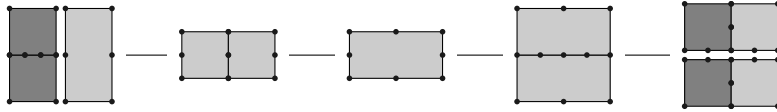

The darker shading indicates that those sectors are assumed to be vacuum sectors in the definition of τ_0 , but will need to be replaced by arbitrary sectors in order to define τ . The first and third isomorphisms are given by the isomorphisms [2-1] or [2-2] (which are equivalent by axiom [3-1]). The second and fourth isomorphisms are given by the $1 \boxtimes 1$ -isomorphism.

In order to promote τ_0 to τ we use the following diagram of functors.

$$\begin{array}{ccccc}
 \text{CN}_1 \times_{\text{CN}_0} \text{CN}_1 & \xrightarrow{I} & (\text{CN}_2 \times_{\text{CN}_1} \text{CN}_2) \times_{\text{CN}_0} \times \text{CN}_1 & \begin{array}{c} \xrightarrow{L} \\ \xrightarrow{R} \end{array} & \text{CN}_2 \\
 \downarrow i_0 & & \downarrow i_1 & & \downarrow i_2 \\
 (\text{CN}_{\sim 2} \times_{\text{CN}_1} \text{CN}_{\simeq 2}) \times_{\text{CN}_0} \times \text{CN}_1 & \xrightarrow{\tilde{I}} & (\text{CN}_{\sim 2} \times_{\text{CN}_1} \text{CN}_{\sim 2}) \times_{\text{CN}_0} \times \text{CN}_1 & \begin{array}{c} \xrightarrow{\tilde{L}} \\ \xrightarrow{\tilde{R}} \end{array} & \text{CN}_{\sim 2}
 \end{array}$$

Here we use the variations of CN_2 introduced earlier. The functors \tilde{L} and \tilde{R} are the canonical extensions of L and R . The functor I applies the identity sector twice in the first entry and has already been defined. The vertical functors i_1 and i_2 are induced from the three inclusions of CN_2 into $\text{CN}_{\sim 2}$, $\text{CN}_{\simeq 2}$, and $\text{CN}_{\sim 2}$. The functor \tilde{I} is induced from the inclusions $\text{CN}_{\simeq 2} \rightarrow \text{CN}_{\sim 2}$ and $\text{CN}_{\simeq 2} \rightarrow \text{CN}_{\sim 2}$. The composition $i_1 \circ I$ canonically factors as $\tilde{I} \circ i_0$.

In the next step we use τ_0 to construct a natural isomorphism $\tilde{\tau}_0: \tilde{L} \circ \tilde{I} \rightarrow \tilde{R} \circ \tilde{I}$. Let $X_0 := (D, E)$ be an object of $\text{CN}_1 \times_{\text{CN}_0} \text{CN}_1$ and let $X = (H_0(D) \otimes \ell, H_0(D) \otimes \ell', E)$ be an

object from $(\text{CN}^{\sim}_2 \times_{\text{CN}_1} \text{CN}_{\sim 2}) \times_{\text{CN}_0} \text{CN}_1$. We have natural identifications $\tilde{L}(\tilde{I}(X)) = L(I(X_0)) \otimes \ell \otimes \ell'$ and $\tilde{R}(\tilde{I}(X)) = R(I(X_0)) \otimes \ell \otimes \ell'$. We set $(\tilde{\tau}_0)_X := (\tau_0) \otimes \text{id}_\ell \otimes \text{id}_{\ell'}$. However, there are more morphisms in $(\text{CN}^{\sim}_2 \times_{\text{CN}_1} \text{CN}_{\sim 2}) \times_{\text{CN}_0} \text{CN}_1$ than there are in $\text{CN}_1 \times_{\text{CN}_0} \text{CN}_1$, and we need to check that $\tilde{\tau}_0$ is natural with respect to these extra morphisms. Note that $\tilde{\tau}_0$ is natural for morphisms from CN_1 , because τ_0 is. By Proposition 6, to check naturality with respect to morphisms in CN^{\sim}_2 , it suffices to consider morphisms of the form

- (i) $f_1 = (H_0(\delta) \otimes \text{id}_\ell, \delta)$, where $\delta : D \mapsto D'$, or
- (ii) $f_2 = (T, \text{id}_D)$ where $T \in D(I) \otimes \mathbf{B}(\ell, \ell')$, for $I = [1, 2]$.

Now $\tilde{\tau}_0$ is natural with respect to morphisms of the first kind because τ_0 is natural for the morphisms from CN_1 . As τ_0 is equivariant for the action of $D(I)$, it follows that $\tilde{\tau}_0$ is also natural for morphisms of the second kind. Similarly, $\tilde{\tau}_0$ is natural for morphisms from $\text{CN}_{\sim 2}$. Thus $\tilde{\tau}_0$ is a natural transformation.

By Proposition 5 every object of $(\text{CN}^{\sim}_2 \times_{\text{CN}_1} \text{CN}_{\sim 2}) \times_{\text{CN}_0} \text{CN}_1$ can be embedded as a direct summand in an object of $(\text{CN}^{\sim}_2 \times_{\text{CN}_1} \text{CN}_{\sim 2}) \times_{\text{CN}_0} \text{CN}_1$. Thus we can extend $\tilde{\tau}_0$ canonically to a natural transformation $\tilde{\tau} : \tilde{L} \rightarrow \tilde{R}$.

Let X be an object from $(\text{CN}_2 \times_{\text{CN}_1} \text{CN}_2) \times_{\text{CN}_0} \text{CN}_1$. Then

$$\tilde{\tau}_{i_1(X)} : \tilde{L}(i_1(X)) \rightarrow \tilde{R}(i_1(X))$$

is a morphism in CN^{\sim}_2 . In fact we will see that $\tilde{\tau}_{i_1(X)}$ is a morphism in CN_2 , and so we can define $\tau_X := \tilde{\tau}_{i_1(X)}$ and obtain the desired natural isomorphism. To check that $\tilde{\tau}_{i_1(X)}$ is in CN_2 , we write $X = ({}_D H_{D'}, {}_{D'} H'_{D''}, E)$, where D , D' , and D'' are \mathcal{A} - \mathcal{B} -defects and E is a \mathcal{B} - \mathcal{C} -defect. For convenience we ignore the collapse map $S_8^1 \mapsto S_6^1$ and think of the $(D \otimes_{\mathcal{B}} E)$ - $(D'' \otimes_{\mathcal{B}} E)$ -sectors $L(X)$ and $R(X)$ as defined on S_8^1 instead of on S_6^1 . We have to show that $\tilde{\tau}_{i_1(X)}$ is equivariant for the actions of $D(I^\sim)$ and $D''(I_\sim)$, where we now view $I^\sim = [1, 2]$ and $I_\sim = [6, 7]$ as subintervals of S_8^1 . Elements of $D(I^\sim)$ and $D''(I_\sim)$ can be viewed as morphisms in CN^{\sim}_2 and $\text{CN}_{\sim 2}$, and therefore as morphisms in $(\text{CN}^{\sim}_2 \times_{\text{CN}_1} \text{CN}_{\sim 2}) \times_{\text{CN}_0} \text{CN}_1$. Therefore the required equivariance of $\tilde{\tau}_{i_1(X)}$ follows from the naturality of $\tilde{\tau}$. This finishes the construction of the right dewhisiker.

[2-7] Left dewhisiker.

The left dewhisiker is defined analogously to the right dewhisiker and is drawn as

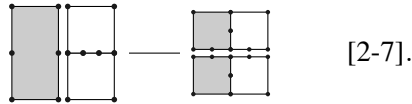

[2-8] Switch.

The switch isomorphism is a composite of two isomorphisms

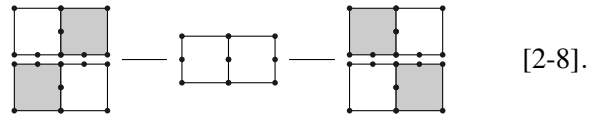

Each of those two isomorphisms is referred to as a half-switch. Arguing as in the construction of the right dewhisiker it suffices to construct these isomorphisms in the cases where all sectors are vacuum sectors. In this case the first half switch is defined as

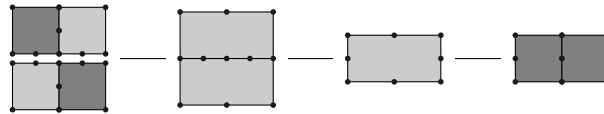

Here the first and third isomorphisms are both the $1 \boxtimes 1$ -isomorphism and the second is [2-1] (which agrees in this case with [2-2]). The second half-switch is defined analogously.

2.C Transformations for horizontal associators

[2-9], [2-10], and [2-11] Whisker associators.

The associators for twice whiskered sectors are given, using the $1 \boxtimes 1$ -isomorphism and the associativity of Connes fusion, as

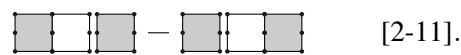
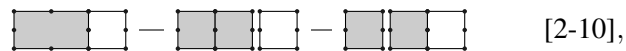
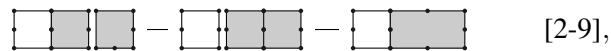

As in the case of the vertical associator [2-3] we will also here often suppress the associator for Connes fusion. In particular, we will suppress [2-11].

[2-12] Horizontal associator.

The associator for the composition of defects is induced from the associator for fusion (or fiber product) of von Neumann algebras and is discussed in [3, Eq 1.55]. Here we will suppress this isomorphism.

In [3, Prop 4.32] we proved that the $1 \boxtimes 1$ -isomorphism is associative in the following sense.

Lemma J. *The $1 \boxtimes 1$ -isomorphism is associative for the composition of defects, that is the following diagram commutes:*

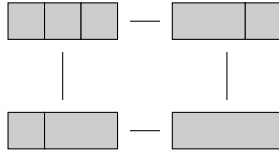

We point out that in the upper left corner of the diagram in this lemma, we have suppressed the morphism of sectors associated to the associator of horizontal fusion. Similarly, in the lower right corner of the diagram we have suppressed the morphism of sectors associated to the associator for fusion of defects.

2.D Transformations for horizontal identities

The 2-data discussed so far is part of the definition of both a 2-category object and a dicategory object (in the 2-category of symmetric monoidal categories). We remind the reader that our 3-category of conformal nets is a dicategory object; the remaining pieces of data labeled here [2-13] to [2-18] are labeled [D2-13] to [D2-18] in the appendix and correspondingly in [8].

Left and right quasi-identity

Let ${}_{\mathcal{A}}D_{\mathcal{B}}$ and ${}_{\mathcal{A}}E_{\mathcal{B}}$ be defects and let ${}_D H_E$ be a sector. There is no canonical isomorphism $H_0(\text{id}_{\mathcal{A}}) \boxtimes_{\mathcal{A}} H \cong H$ in CN_2 . In fact, $H_0(\text{id}_{\mathcal{A}}) \boxtimes_{\mathcal{A}} H$ is an $(\text{id}_{\mathcal{A}} \otimes_{\mathcal{A}} D)$ - $(\text{id}_{\mathcal{A}} \otimes_{\mathcal{A}} E)$ -sector and not a D - E -sector. There is however such an isomorphism if we are willing to twist H on top and bottom by the diffeomorphism Φ_L introduced in

the construction of the left identity [1-7]. The left quasi-identity has been constructed in [3, Def 6.20] (where it was called the “left unitor” $\hat{\Upsilon}^l$), and will be drawn as

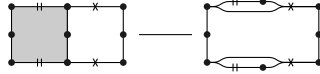

Here the balloons on the right box signal that the D - E -sector structure on H has been twisted to an $(\text{id}_{\mathcal{A}} \otimes_{\mathcal{A}} D)$ - $(\text{id}_{\mathcal{A}} \otimes_{\mathcal{A}} E)$ -sector structure using $\mathcal{A}(\Phi_L)$ at the indicated portions of the picture. Of course we can move one or two of the balloons to the left box by composing with the appropriate inverse diffeomorphism. For example we obtain from the left quasi-identity an isomorphism of $(\text{id}_{\mathcal{A}} \otimes_{\mathcal{A}} D)$ - E -sectors drawn as

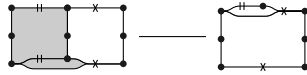

Similarly, there is a right quasi-identity using Φ_R drawn as

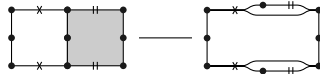

The next two lemmas are proved respectively in [3, Eq 6.23] and in [3, Lem 6.21].

Lemma K. *The following diagram commutes:*

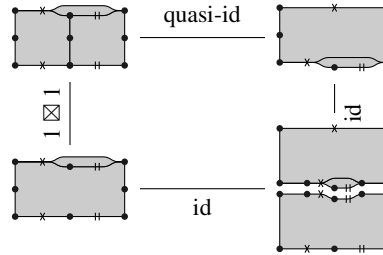

Lemma L. *The $1 \boxtimes 1$ -isomorphism is, in the following sense, natural with respect to the left quasi-identity—this diagram commutes:*

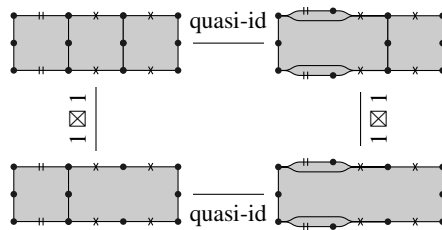

Similarly, there are “right versions” of Lemma K and Lemma L for the right quasi-identity.

[2-13] Left identity pass.

The pass through a left identity is defined as the following composite

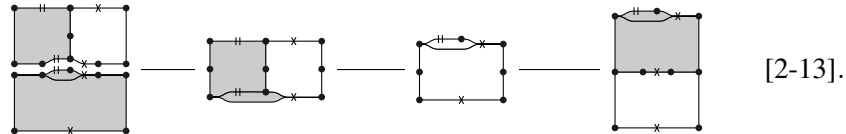

For the first map observe that we can move the diffeomorphism from the lower defect to the horizontal composition of the two upper defects. The first map is then obtained by the bottom identity [2-2]. The second map is obtained from the left quasi-identity by applying the inverse of Φ_L on the lower half—this moves the lower bubble from the right hand picture to the left hand picture. The third map is the top identity [2-1].

[2-14] Right identity pass.

The pass through a right identity is a reflection along a vertical axis of the pass through a left identity, and is defined similarly:

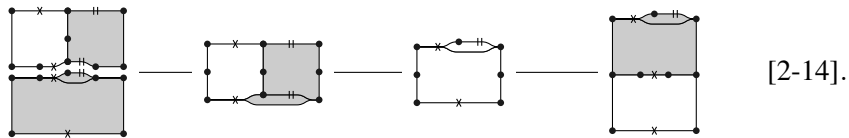

[2-15] Swap.

The swap is an isomorphism

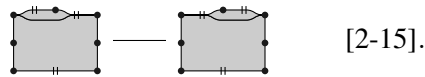

The construction of the swap depends on the flip and will be given after the construction of the flip below.

[2-16] Left identity expansion.

The left identity expansion is obtained from the $1 \boxtimes 1$ -isomorphism and is drawn as

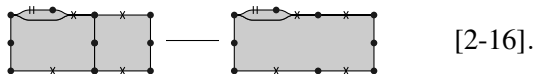

[2-17] Right identity expansion.

The right identity expansion is a reflection along a vertical axis of the left identity expansion, and is defined similarly:

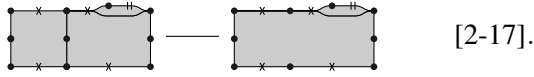

[2-18] Flip.

The flip is an isomorphism

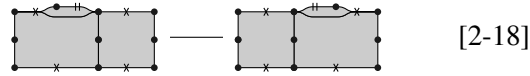

and is defined as follows. Note that both the left and right hand side of the flip are obtained from the horizontal composition of two identity sectors

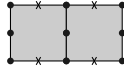

by two different diffeomorphism ϕ_L, ϕ_R from an interval of length 2 to an interval of length 1—the intervals under consideration are those between the non-identity defect points. (The diffeomorphisms ϕ_L and ϕ_R are extensions by an identity of the restrictions of the diffeomorphisms Φ_L and Φ_R used in the construction of the left identity [1-7] and right identity [1-8].) Note that ϕ_L and ϕ_R coincide on a neighborhood of the boundary of this interval. In order to define the flip we need to implement the diffeomorphism $\phi := \phi_R \circ (\phi_L)^{-1}$; this is possible, because ϕ acts as the identity in a neighborhood of the boundary of the interval. However, there is no canonical implementation. In order to choose these implementations consistently we proceed as follows. The group $\text{Diff}_0([0, 1])$, of diffeomorphisms that are the identity on a neighborhood of the boundary, is perfect by [12]. Thus it admits a universal central extension $\pi: \widetilde{\text{Diff}}_0([0, 1]) \rightarrow \text{Diff}_0([0, 1])$. For any net \mathcal{A} we can implement any $\varphi \in \text{Diff}_0([0, 1])$ by a unitary $U_\varphi \in U(\mathcal{A}(I))$; thus $U_\varphi a U_\varphi^* = \mathcal{A}(\varphi)(a)$ for all $a \in \mathcal{A}([0, 1])$. Moreover, U_φ is unique modulo the center $Z(\mathcal{A}([0, 1]))$. This induces a unique homomorphism $U: \widetilde{\text{Diff}}_0([0, 1]) \rightarrow \mathcal{A}([0, 1])$ such that $U_{\tilde{\varphi}} a U_{\tilde{\varphi}}^* = \mathcal{A}(\pi(\tilde{\varphi}))(a)$ for all $a \in \mathcal{A}([0, 1])$, and all $\tilde{\varphi} \in \widetilde{\text{Diff}}_0([0, 1])$. The uniqueness of this map implies that it is compatible with tensor products of nets. Now we choose $\tilde{\phi}$ such that $\pi(\tilde{\phi}) = \phi$. The flip is the map induced by the action of $U_{\tilde{\phi}}$. (Though the flip map depends on

the choice of lift $\tilde{\phi}$, the overall resulting 3-category does not, up to isomorphism—see Remark 7 below.)

We note that $U_{\tilde{\phi}}$ also provides an isomorphism

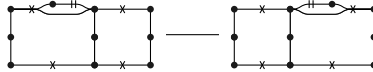

for general sectors. This generalization of the flip will be helpful in Lemma M below.

Construction of the swap [2-15]

The domain and target of the swap isomorphism are obtained by twisting the vacuum sector of the same identity defect with different diffeomorphisms. Using implementation of diffeomorphisms for the net in question we can implement the difference between these diffeomorphisms (as in the construction of the flip [2-18]) and see that domain and target of the swap are indeed isomorphic. However, there is a priori no preferred implementation and therefore no canonical choice for the swap. Because every net can be canonically written as a direct sum of irreducible nets, it suffices to determine the swap for irreducible nets. In this case there is up to phase a unique implementation. Therefore it remains to determine the phase of the swap in this case. Consider the diagram

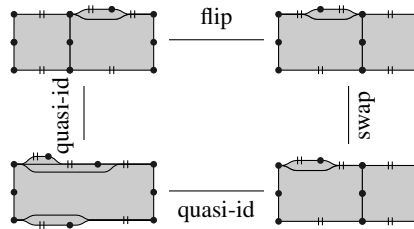

Here the lower horizontal map is obtained by twisting the quasi-identity

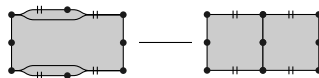

while the left vertical map is obtained by applying the quasi-identity to the left identity

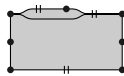

(In particular, for the lower horizontal map in the above square diagram, the inner diffeomorphism of the two upper diffeomorphisms in the lower left hand item is added

by the quasi-identity; by contrast, for the left vertical map the outer of those two diffeomorphisms is added by the quasi-identity.) The phase of the swap is now fixed by requiring the above diagram to commute.

The defining diagram for the swap generalizes as follows.

Lemma M. *The following diagram commutes*

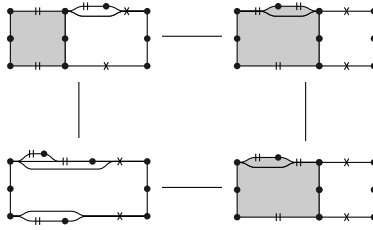

Later we will only need Lemma M for vacuum sectors, but the proof of the more general statement is a bit cleaner.

Proof We denote the non-vacuum sector in the diagram by ${}_D H_E$. Here ${}_A D_B$ and ${}_A E_B$ are defects. If $D = \text{id}_A$ and $H = H_0(\text{id}_A)$, then the diagram commutes by the construction of the swap. This also implies that the diagram commutes if $H = H_0(\text{id}_A) \otimes \ell$ for any Hilbert space ℓ . For $\varepsilon > 0$ we now use the subinterval $I_\varepsilon = [-1.5 + \varepsilon, 1.5 - \varepsilon]$ of the circle S^1_6 bounding the non-vacuum sector. There exists an $\mathcal{A}(I_\varepsilon)$ -linear isometry $U_\varepsilon : H_0(\text{id}_A) \otimes \ell \rightarrow H \otimes \ell$. If ε is sufficiently small, then U_ε will commute with all four sides of the above diagram. Thus the square also commutes for $H \otimes \ell$ and thus for H itself. \square

Remark 7 The flip isomorphism [2-18] and the swap isomorphism [2-15] depended on the choice of lift $\tilde{\phi}$ of the diffeomorphism $\phi := \phi_R \circ (\phi_L)^{-1}$; changing the lift changes the flip by a scalar and the swap by the inverse scalar. However, the symmetric monoidal 3-categories resulting from distinct choices are canonically isomorphic, as follows. (Here the isomorphism will be given by a functor $A \rightarrow B$ of dicategory objects in symmetric monoidal categories, which is a triple of functors $A_0 \rightarrow B_0$, $A_1 \rightarrow B_1$, $A_2 \rightarrow B_2$, together with eight symmetric monoidal natural transformations, comparing each piece of 1-data for A with the corresponding piece of 1-data for B , such that eighteen squares of natural transformations commute, one for each piece of 2-data.)

Recall that the left identity [1-7] and right identity [1-8] depended on a choice of diffeomorphism Φ_L . Assume for a moment the diffeomorphism Φ_L is fixed; let $\text{CN}[\Phi_L, \tilde{\phi}]$ denote the dicategory object resulting from the choice $\tilde{\phi}$ of lift of ϕ , and let

$\text{CN}[\Phi_L, \bar{\phi}]$ denote the dicategory object resulting from the alternative choice of lift $\bar{\phi}$ of ϕ . The ratio $\bar{\phi}/\tilde{\phi}$ is an invertible scalar. There is therefore a canonical isomorphism of dicategory objects $\text{CN}[\Phi_L, \tilde{\phi}] \rightarrow \text{CN}[\Phi_L, \bar{\phi}]$ which is the identity functor on all 0-data, and the identity natural transformation on the 1-data [1-1] through [1-7], but is the natural transformation given by scalar multiplication by $(\bar{\phi}/\tilde{\phi})^{-1}$ on the 1-data [1-8]. These natural transformations commute with all the 2-data.

We can moreover remove the dependence of the 3-category CN on the choice of the diffeomorphism Φ_L . Suppose Φ'_L is an alternative choice of diffeomorphism suitable for the construction of the left identity. Choose a lift $\tilde{\Lambda} \in \widetilde{\text{Diff}}_0[.5, 1.5]$ of the diffeomorphism $\Lambda := \Phi'_L|_{[1.5, 2.5]} \circ (\Phi_L)^{-1}|_{[.5, 1.5]}$. Recall from the section on the right identity [1-8] that Φ_R is the reflection of the diffeomorphism Φ_L ; similarly we let Φ'_R be the corresponding reflection of Φ'_L . The lift $\tilde{\Lambda}$ determines by reflection a lift \tilde{P} of $P := \Phi'_R|_{[1.5, 3.5]} \circ (\Phi_R)^{-1}|_{[1.5, 2.5]}$. As before, let $\tilde{\phi}$ be a lift of $\phi := \phi_R \circ (\phi_L)^{-1}$. Note that the diffeomorphisms $\phi_L : [1.5, 3.5] \rightarrow [1.5, 2.5]$ and $\phi_R : [1.5, 3.5] \rightarrow [1.5, 2.5]$ were, up to a shift, determined by restrictions of Φ_L and Φ_R ; more specifically $\phi_L(x) = \Phi_L(x - 1) + 1$ and $\phi_R(x) = \Phi_R(x)$. Therefore, the product $\tilde{\phi}' := \tilde{P} \cdot \tilde{\phi} \cdot [\tilde{\Lambda}]^{-1}$ is a lift of $\phi' := \phi'_R \circ (\phi'_L)^{-1}$, where $[-]$ denotes the canonical shift isomorphism from $\widetilde{\text{Diff}}_0[.5, 1.5]$ to $\widetilde{\text{Diff}}_0[1.5, 2.5]$.

Now let $U_{\tilde{\Lambda}} \in \mathcal{A}([.5, 1.5])$ be the unitary, associated to $\tilde{\Lambda}$, implementing $\mathcal{A}(\Lambda)$; here $U : \widetilde{\text{Diff}}_0([.5, 1.5]) \rightarrow \mathcal{A}([.5, 1.5])$ is the homomorphism described in the section on the flip. The action of $U_{\tilde{\Lambda}}$ provides a natural isomorphism from the left identity of $\text{CN}[\Phi_L, \tilde{\phi}]$ (a functor $\text{CN}_1 \rightarrow \text{CN}_2$) to the left identity of $\text{CN}[\Phi'_L, \tilde{\phi}']$ (also a functor $\text{CN}_1 \rightarrow \text{CN}_2$). Similarly, the action of the unitary $U_{\tilde{P}} \in \mathcal{B}([1.5, 2.5])$ implementing $\mathcal{B}(P)$, provides a natural isomorphism from the right identity of $\text{CN}[\Phi_L, \tilde{\phi}]$ to the right identity of $\text{CN}[\Phi'_L, \tilde{\phi}']$. Altogether, this constructs an isomorphism of dicategory objects $\text{CN}[\Phi_L, \tilde{\phi}] \rightarrow \text{CN}[\Phi'_L, \tilde{\phi}']$ which is the identity functor on all 0-data, is the identity natural transformation on the 1-data [1-1] through [1-6], and is the natural transformation $U_{\tilde{\Lambda}}$ on [1-7] and the natural transformation $U_{\tilde{P}}$ on [1-8]—these natural transformations commute with all the 2-data.

3 Coherence axioms for compatibility transformations

3.A Axioms for vertical identity and composition

Proposition Axiom [3-1] is satisfied.

Proof Axiom [3-1] asserts that top and bottom identity agree in the case where both sectors are vacuum sectors. This holds because the corresponding statement is already true for Connes fusion. \square

Proposition Axioms [3-2] and [3-3] are satisfied.

Proof Axioms [3-2] and [3-3] assert that top and bottom identity are compatible with the vertical associator. This holds because the corresponding statement is already true for Connes fusion. \square

Proposition Axiom [3-4] is satisfied.

Proof Axiom [3-4] asserts that the vertical associator satisfies the pentagon identity. This holds because the associator for Connes fusion satisfies the pentagon identity. \square

Remark It is possible to base the definition of sectors on a square rather than a hexagon and to define vertical fusion using just a side of this square (rather than half of the hexagon). Then our pictures would become a little simpler, but vertical composition would require a diffeomorphism and the associator would then involve this diffeomorphism. Axioms [3-1] through [3-4] would be more cumbersome to prove in such a set-up.

3.B Axioms for horizontal composition and whiskers

Proposition Axiom [3-5] is satisfied.

Proof The argument is summarized by the following diagram.

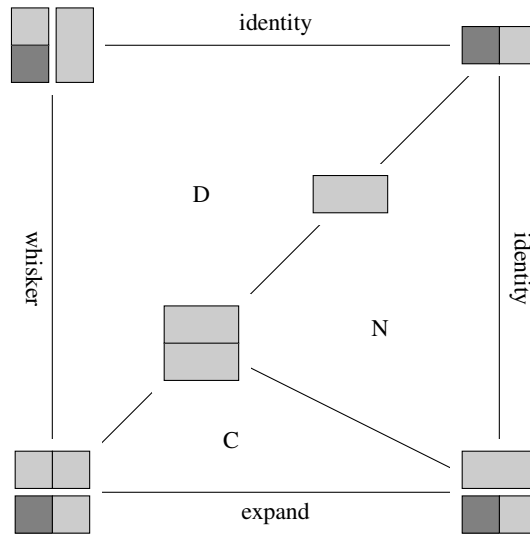

Each of the four corners of the diagram denotes a functor $CN_2 \times_{CN_0} CN_1 \rightarrow CN_2$. Each of the four lines on the boundary of the diagram denotes a natural isomorphism determined by its label. These four natural isomorphisms (simply referred to as *maps* for brevity) are explained in more detail as follows.

- The map labeled “whisker” is the “right dewhisker” [2-6].
- The horizontal map labeled “identity” is obtained by applying the top identity [2-1] to the left half of the item in the top left corner of the diagram.
- The right vertical map labeled “identity” is obtained by applying the top identity [2-1].
- The horizontal map labeled “expand” is obtained by applying the left (or equivalently right) vertical identity expansion [2-4] to the top half of the item in the lower left corner of the diagram.

Axiom [3-5] asserts that the boundary of this diagram commutes, that is, if we start at some corner of the diagram and compose the four maps along the boundary of the diagram then we should obtain the identity natural transformation on the functor corresponding to the corner where we started. (We remark that in [8], the axiom is

rotated by $-\pi/2$ from the version depicted above.) Now observe that each corner of the diagram can also be viewed as determining a functor $CN_{\sim 2} \times_{CN_0} CN_1 \rightarrow CN_{\sim 2}$. And similarly each map on the boundary describes a natural isomorphism between these functors. Moreover, the question whether the diagram commutes or not is invariant under this change from CN_2 to $CN_{\sim 2}$. But the $CN_{\sim 2}$ -version has the advantage that because of Proposition 5, it suffices to check the commutativity of the diagram in the case when the darker shaded sector is an identity sector, not an arbitrary sector. Therefore we can and will assume that this sector is also an identity sector. Under this assumption, the internal maps and nodes of the diagram make sense. Axiom [3-5] will follow, once we have shown that the three cells in the interior commute.

The cell labeled “D”. The composition of the maps not labeled “whisker” around this cell is the definition of the map labeled “whisker”. Thus this cell commutes by definition. This is the reason for the label “D”.

The cell labeled “N”. The map that is counterclockwise after the map labeled “identity” is the left (or equivalently right) vertical identity expansion [2-4]. The map clockwise after the map labeled “identity” is the vertical fusion of the identity (on the top) and the left vertical identity expansion (on the bottom). The remaining map is a top identity (as is the map labeled identity). Thus this cell commutes by the naturality of the top identity map. This is the reason for the label “N”.

The cell labeled “C”. Consider the item in the lower left corner of the diagram. Here we can apply the left (or right) vertical identity expansion [2-4] to both the bottom and top half of this item. These applications do not interact with each other and can be done in any order or simultaneously. All three maps on the boundary of this cells are obtained from these commuting operations. The cell therefore commutes. We recorded this in the diagram by the label “C”, for commuting operations. \square

Formally the proofs of the remaining axioms will be very similar to the proof of axiom [3-5]. We will however not repeat the arguments in every case in detail. In particular, we will trust the reader to determine the correct maps from our pictures. Moreover, the trick that allows us to assume that some sector is not an arbitrary sector but an identity sector (by replacing CN_2 temporarily with $CN_{\sim 2}$ or $CN^{\sim 2}$) will be used very often in the remainder of this paper. We will always refer to this as the *corner trick* and indicate the sector to which it is applied by a darker shading.

Proposition Axiom [3-6] is satisfied.

Proof This axiom asserts that the following diagram commutes

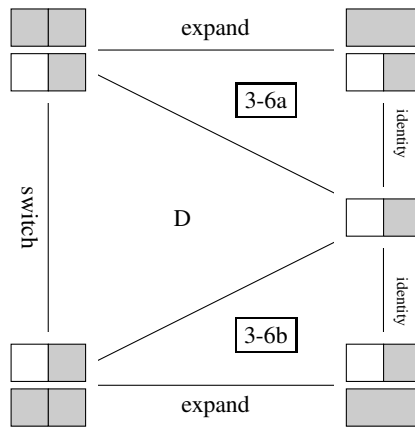

The diagonal maps are the two half-switches from the definition of the switch isomorphism [2-8]. Thus the cell labeled “D” commutes by definition. There is a mirror symmetry between the two remaining cells. Thus it suffices to prove that [3-6a] commutes: this is the content of the next lemma. \square

Lemma The diagram [3-6a] commutes.

Proof The argument is similar to the proof of Axiom [3-5] and is summarized as

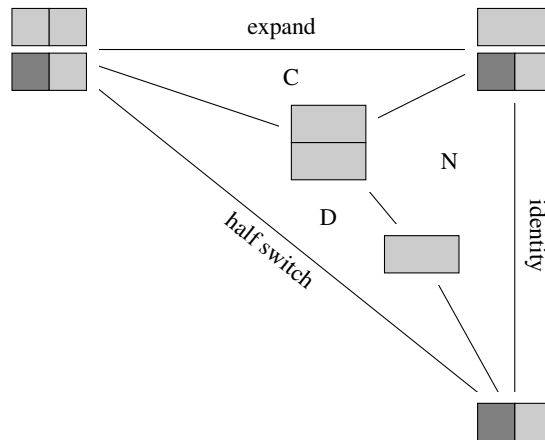

\square

Proposition Axiom [3-7] is satisfied.

Proof The argument is summarized as

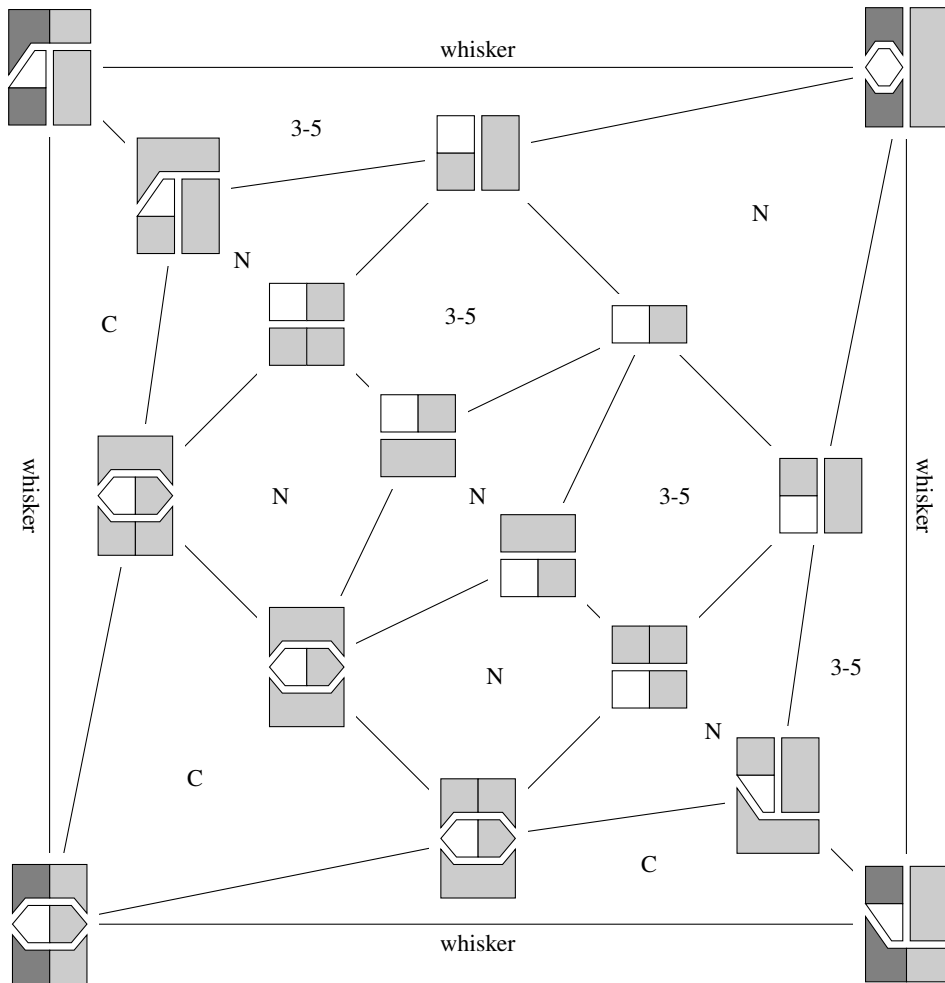

The boundary of this diagram is a square, not a hexagon as in [8], because we suppress the vertical associativity isomorphisms. To help the reader to decode the precise meaning of the items of this diagram we give a more detailed picture of the left top corner where the bullets are added (even though these can be reconstructed from the

form of the picture).

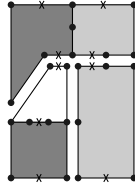

Each cell of the diagram commutes for the reason indicated in the diagram. □

Proposition Axiom [3-8] is satisfied.

Proof Consider the diagram

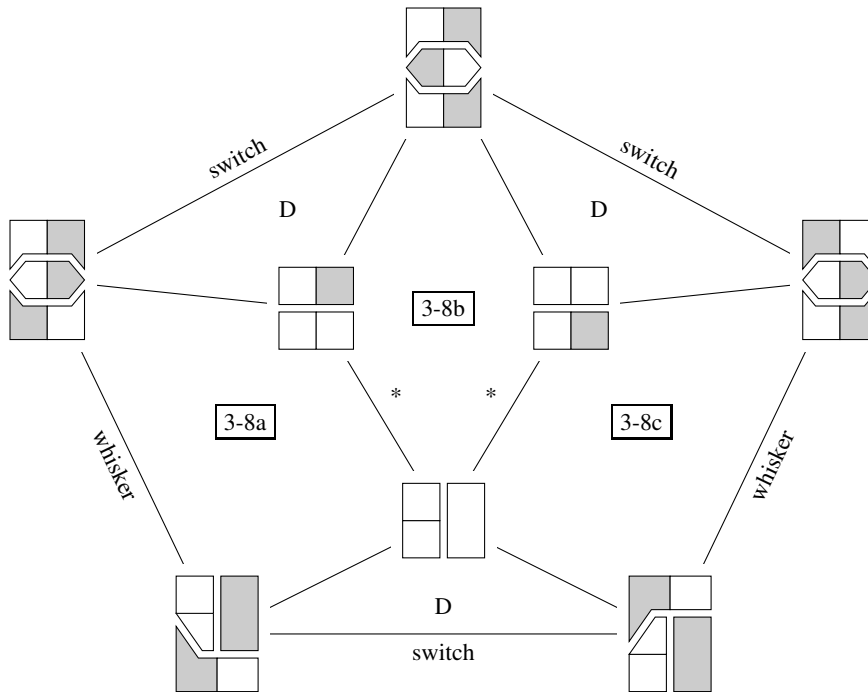

Here, the left isomorphism labeled $*$ is defined using the corner trick (as in the construction of the right dewhisiker [2-6]) to be the following composite:

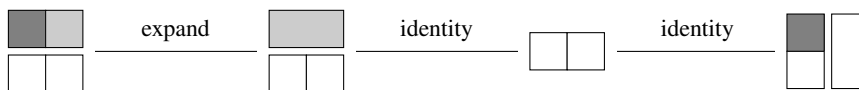

The second isomorphism labeled * is defined similarly. There is a horizontal symmetry between the cells labeled [3-8a] and [3-8c]. Thus it suffices to prove that [3-8a] and [3-8b] commute. This is the content of the next two lemmas. \square

Lemma The diagram [3-8a] commutes.

Proof Applying the corner trick twice, the cell [3-8a] can be filled as follows:

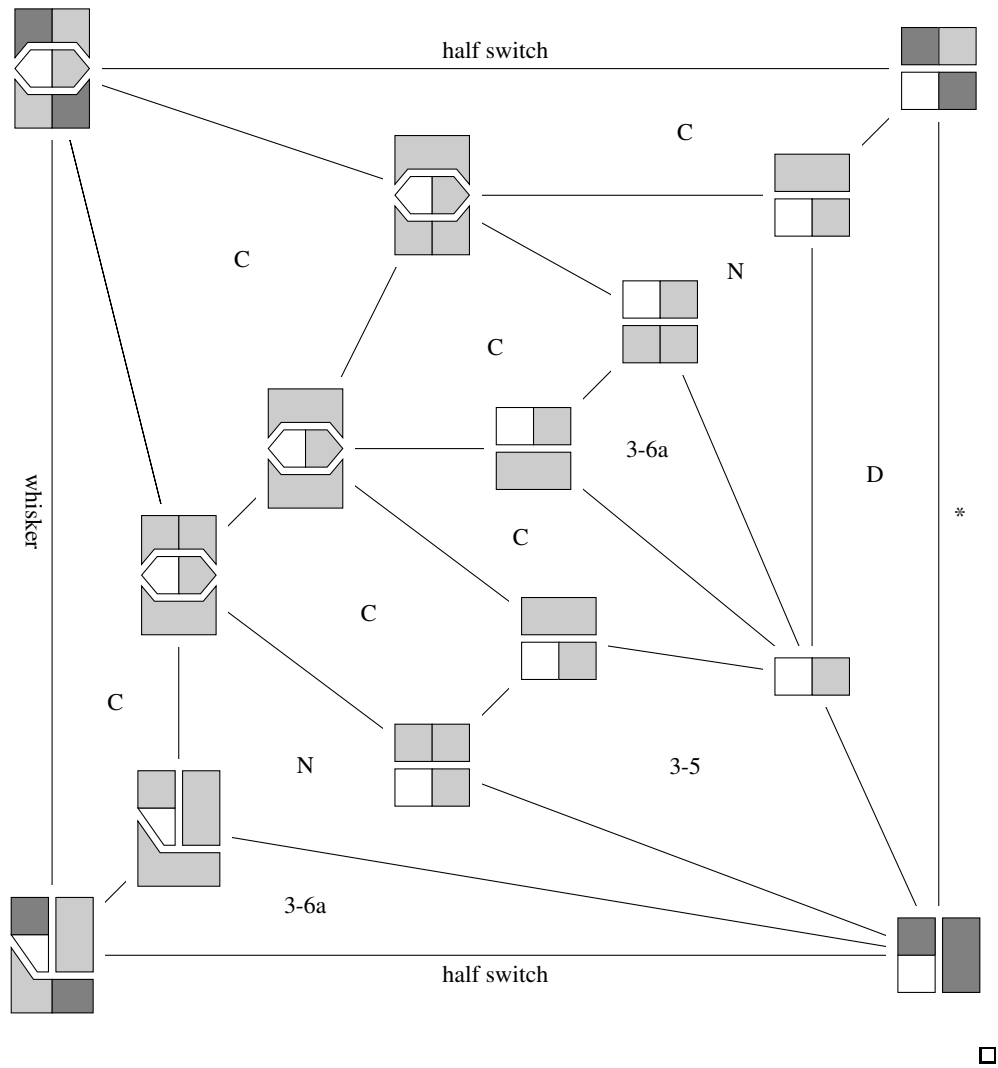

Lemma The diagram [3-8b] commutes.

Proof Using the corner trick twice, we fill the cell [3-8b] as follows:

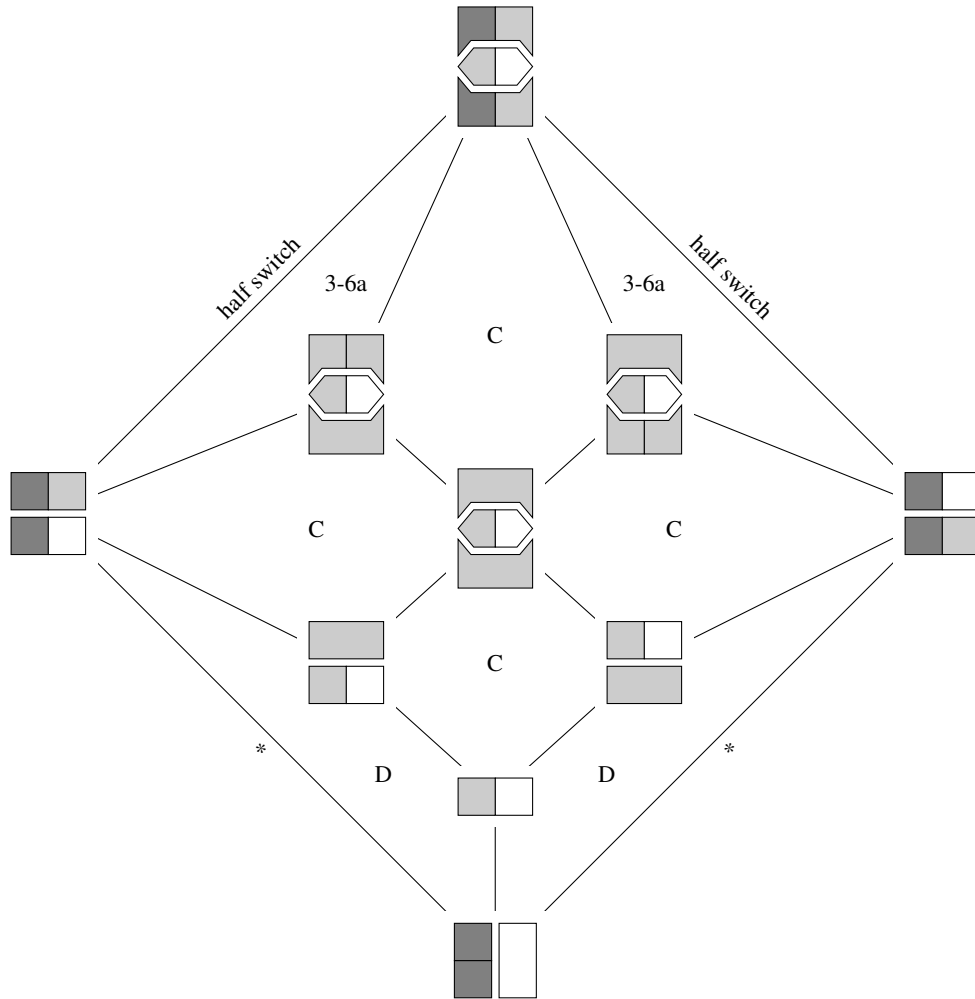

□

3.C Axioms for horizontal associators

Proposition Axioms [3-9] and [3-10] are satisfied.

Proof Both are a consequence of the associativity of the $1 \boxtimes 1$ -isomorphism, in the form of Lemma J. □

Proposition Axiom [3-11] is satisfied.

Proof Using the corner trick this axiom is proved by this diagram:

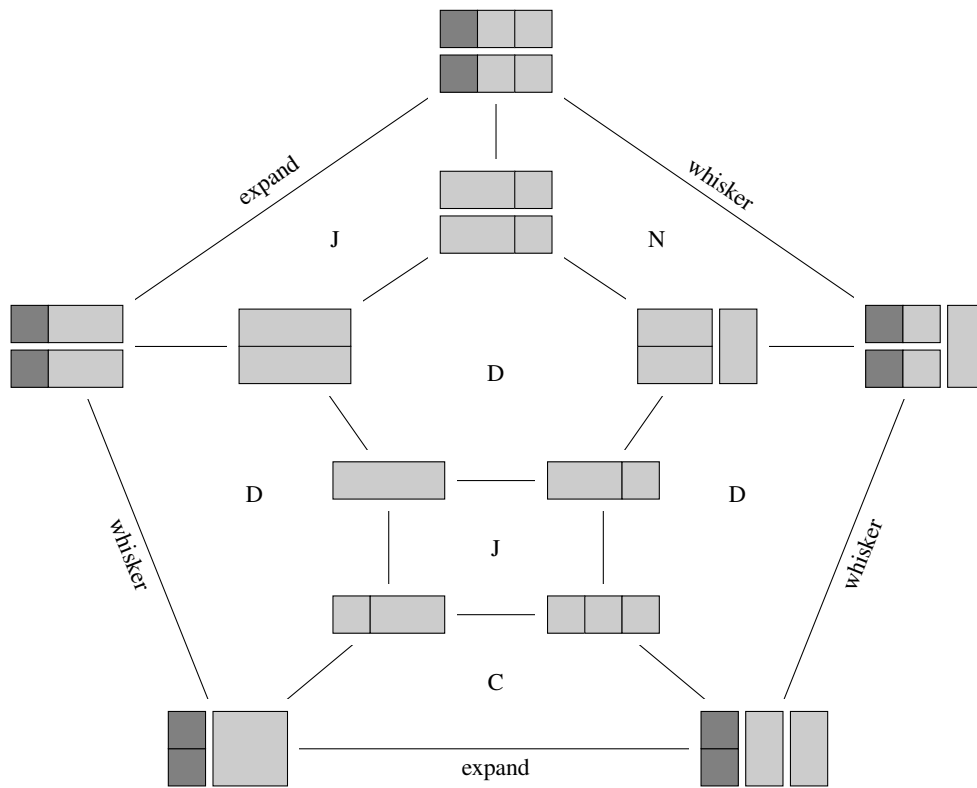

The cells labeled “J” commute by Lemma J. □

Proposition Axiom [3-12] is satisfied.

Proof The formulation of axiom [3-12] simplifies from a hexagon to a square because we suppress the whisker associator [2-11]. Using the corner trick we can fill in this

square as follows:

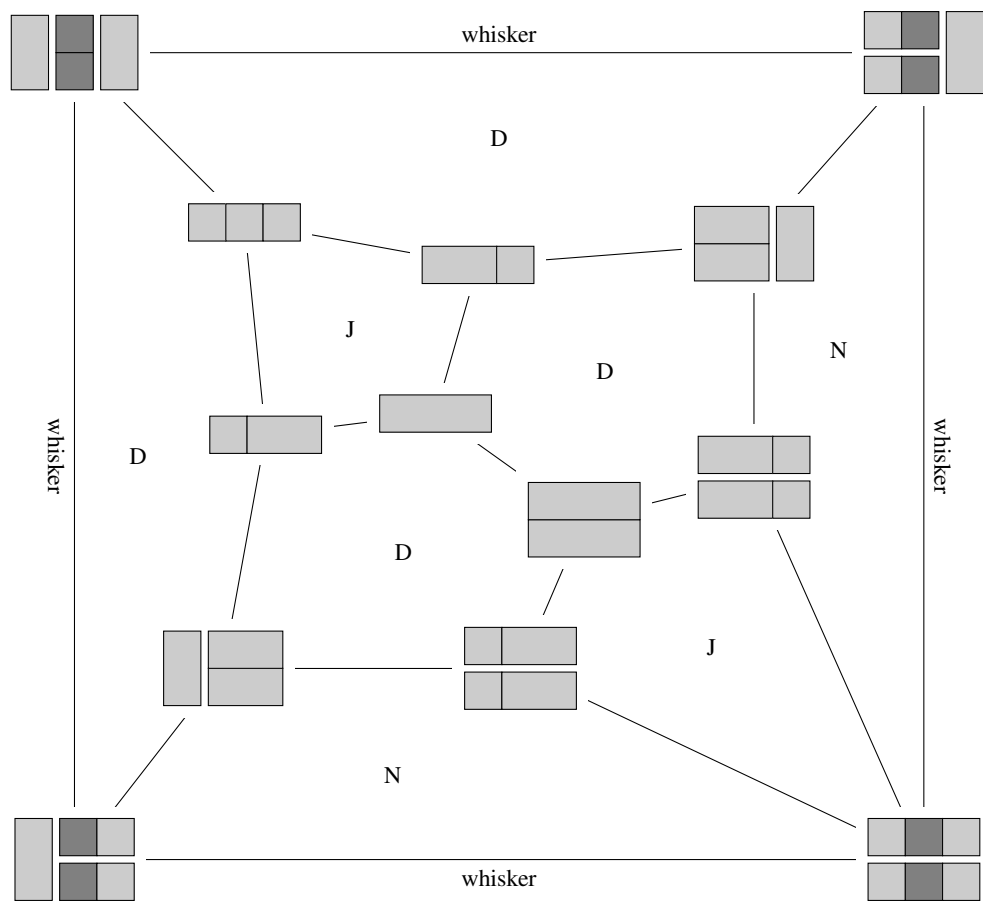

□

Proposition Axiom [3-13] is satisfied.

Proof The axiom follows from the commutativity of the following diagram:

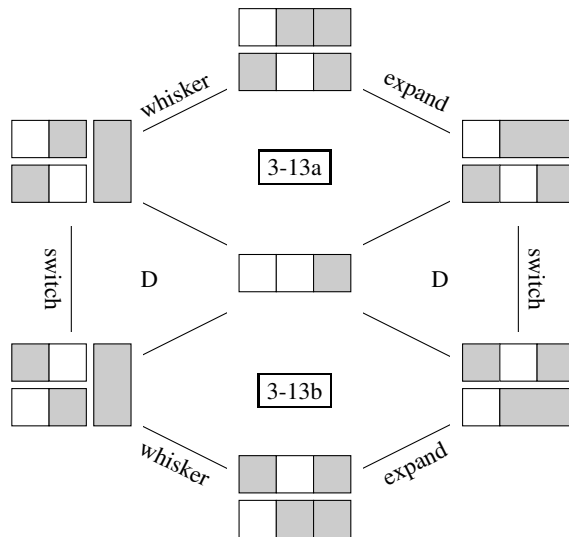

There is a horizontal symmetry between the cells labeled [3-13a] and [3-13b]. Thus it remains to prove that [3-13a] commutes. This is the content of the next lemma. \square

Lemma The diagram [3-13a] commutes.

Proof Using the corner trick we can fill in the diamond as follows:

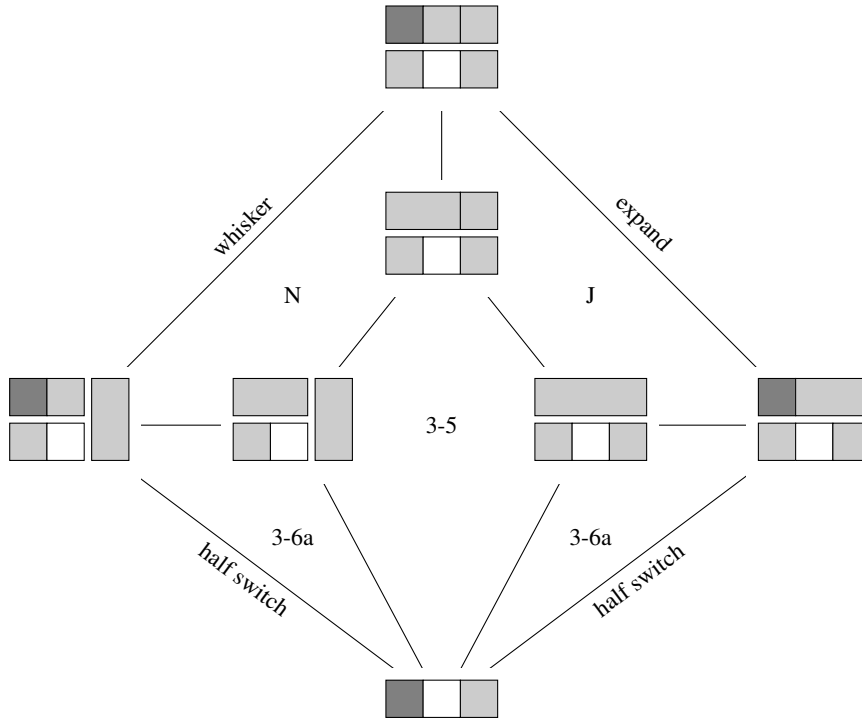

□

Proposition Axiom [3-14] is satisfied.

Proof The axiom follows from the commutativity of the diagram

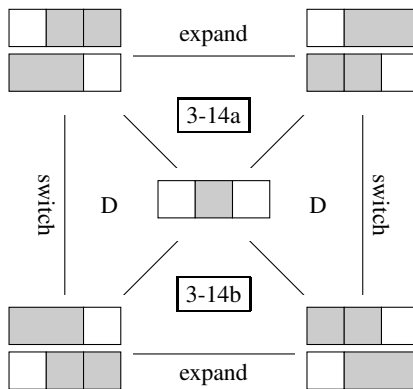

There is a horizontal symmetry between the cells [3-14a] and [3-14b]. Thus it suffices to show that [3-14a] commutes. This is the content of the next lemma. \square

Lemma The diagram [3-14a] commutes.

Proof Using the corner trick twice we can fill in [3-14a] as follows:

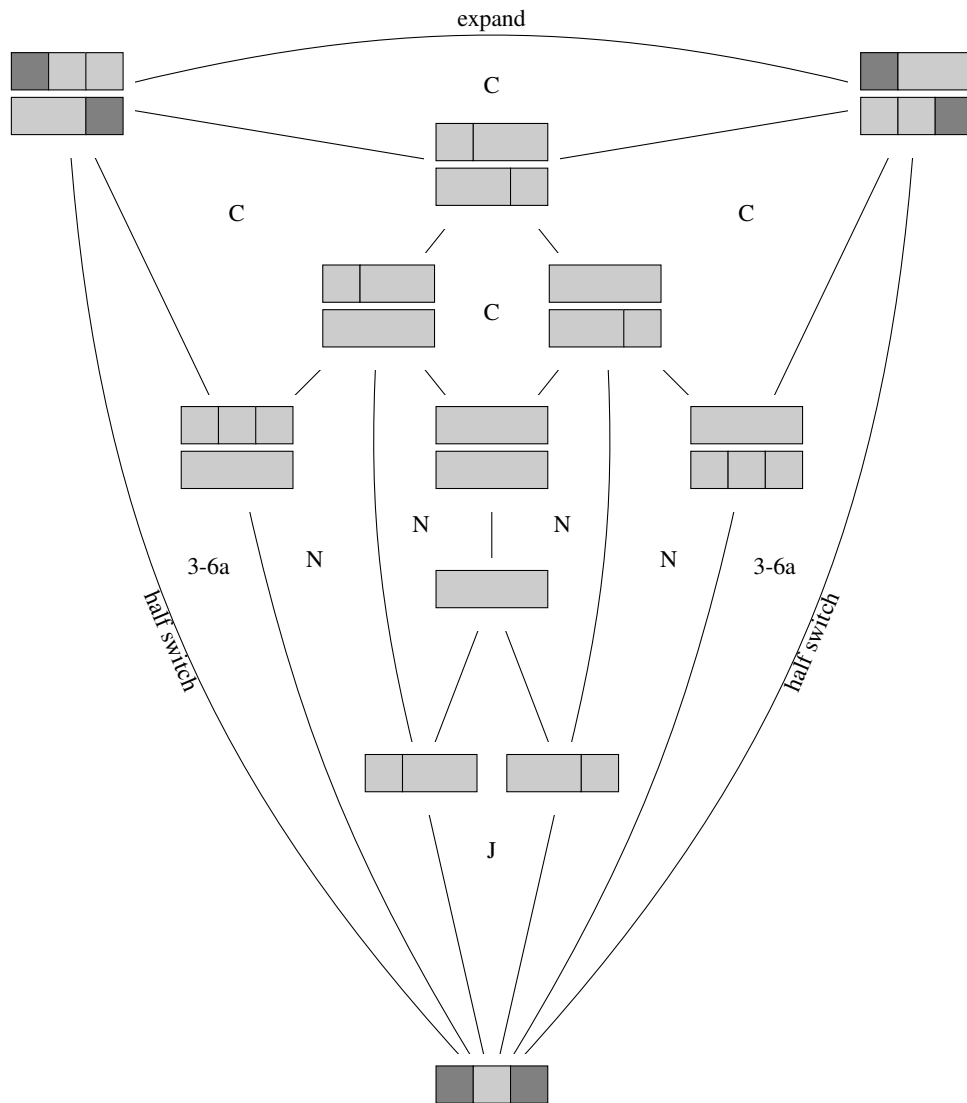

\square

Proposition Axiom [3-15] is satisfied.

Proof This axiom follows from the associativity of the $1 \boxtimes 1$ -isomorphism (Lemma J):

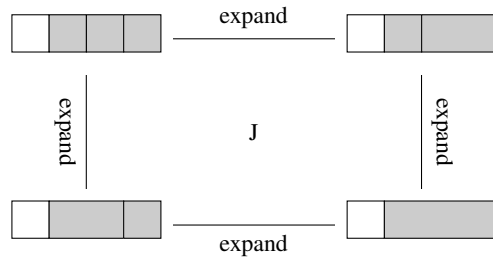

□

Proposition Axiom [3-16] is satisfied.

Proof Upon suppression of horizontal associators, three of the nodes of the axiom reduce to the left hand picture below. The remaining two nodes reduce to the right hand picture; both edges between these sets of nodes are the indicated expansion:

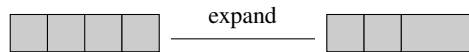

□

Proposition Axiom [3-17] is satisfied.

Proof This axiom asserts that the associator for defects [2-12] satisfies the pentagon identity. This holds because the corresponding statement is already true for fusion (or fiber product) of von Neumann algebras. □

3.D Axioms for horizontal identities

The axioms [3-1] to [3-17] do not involve identity defects. These axioms are part of the definition of both a 2-category object and a dicategory object (in the 2-category of symmetric monoidal categories). The remaining axioms labeled here [3-18] to [3-26] are the axioms labeled [D3-18] to [D3-26] in the appendix and correspondingly in [8].

Proposition Axiom [3-18] is satisfied.

Proof This axiom follows from the commutativity of this diagram:

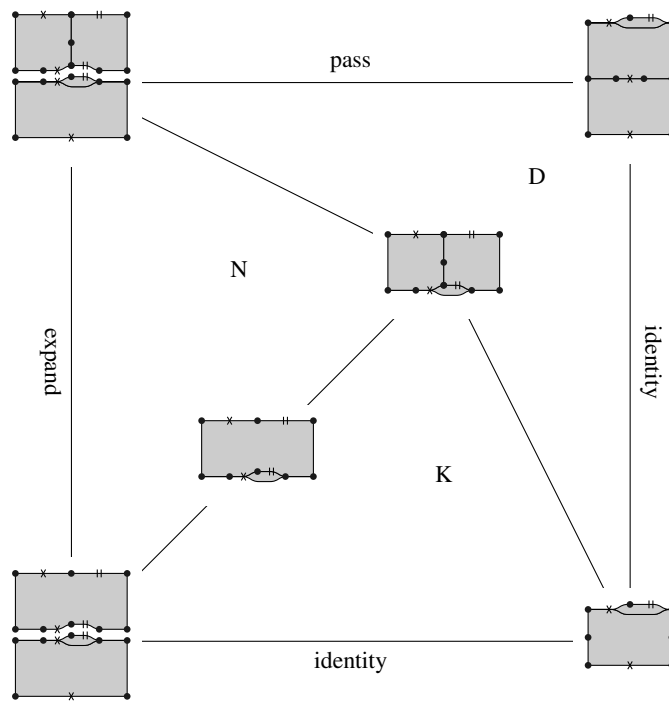

The cells labeled “N” and “D” commute by naturality and by definition. The remaining cell commutes for a reason that we have not yet encountered, namely by Lemma K. \square

Proposition Axiom [3-19] is satisfied.

Proof Axiom [3-19] reduces to a square, because we are suppressing the vertical associator [2-3]. We can partially fill the square as follows. For readability and ease of comparison with a subsequent diagram, we use the abbreviated notation for the four corner configurations, and the full bullet and bubble notation for the interior

configurations.

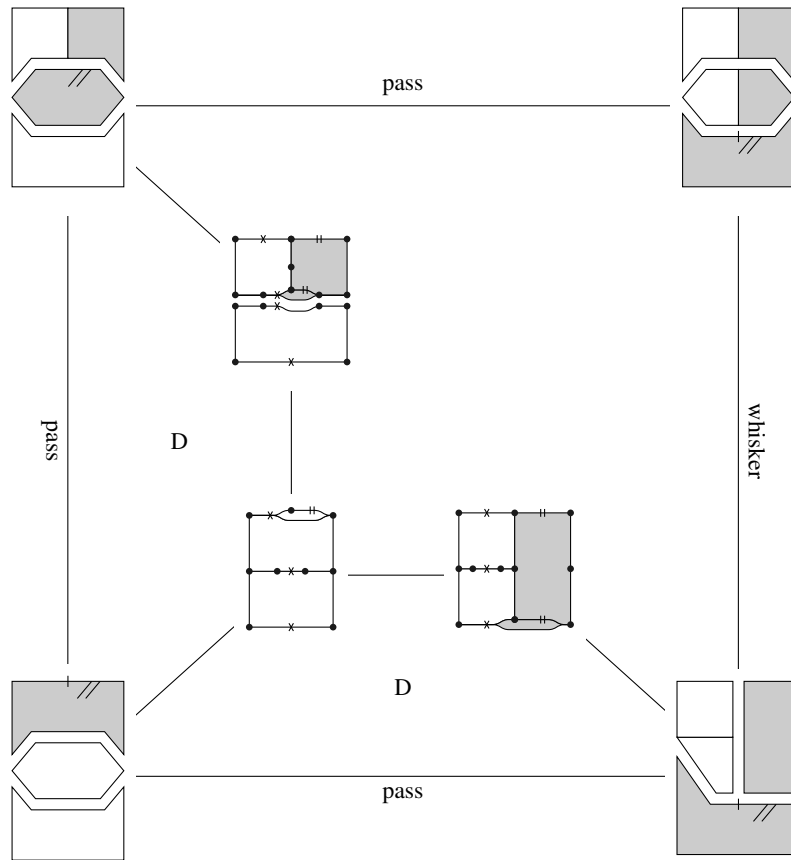

For the remaining cell we can use the corner trick and assume that the top left sector is an identity sector. This reduces axiom [3-19] to the case where only one of the sectors is not an identity sector. Using this additional assumption we can fill in Axiom [3-19] as follows (using the simpler notation that suppresses the bullets and bubbles

for diffeomorphisms):

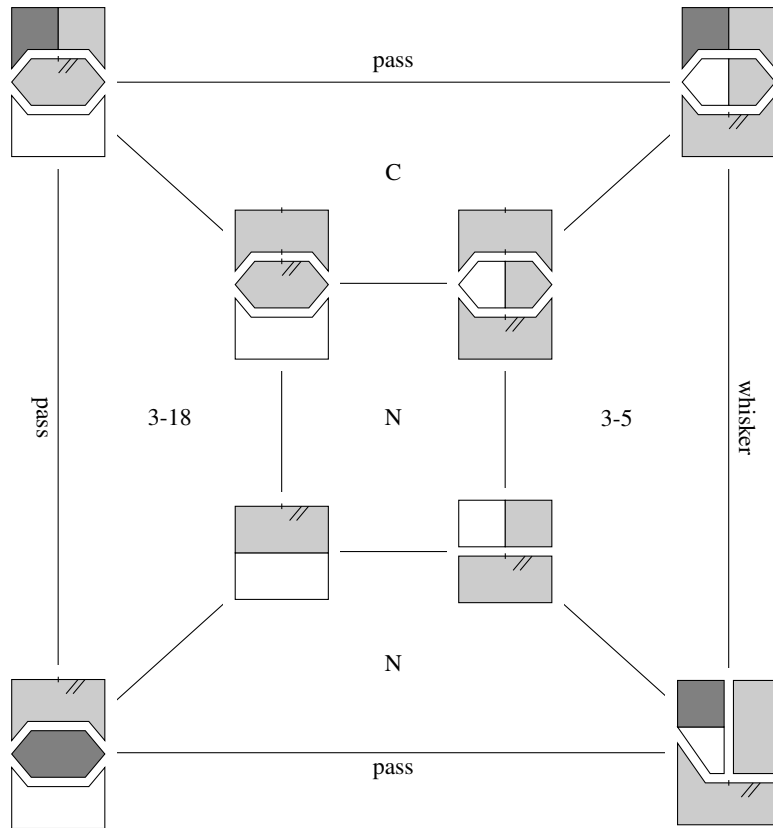

□

Proposition Axiom [3-20] is satisfied.

Proof We can fill in axiom [3-20] partially as follows:

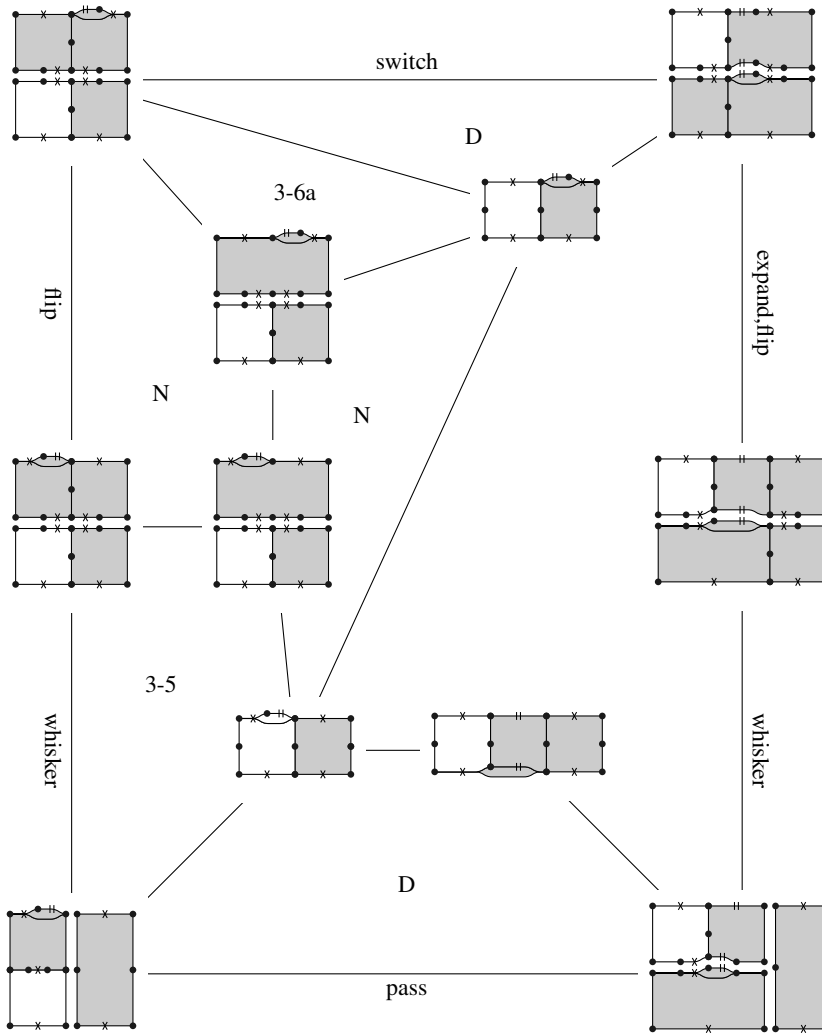

Here we used the more precise notation using bullets and bubbles. The above diagram shows that axiom [3-20] is equivalent to the commutativity of the remaining hexagon. By the corner trick this hexagon commutes if and only if it commutes for the identity sector, and the hexagon with identity sector commutes if and only if axiom [3-20] commutes for the identity sector. Thus it suffices to establish axiom [3-20] for the identity sector. This follows from the following diagram (where we drop bullets and

bubbles from the notation).

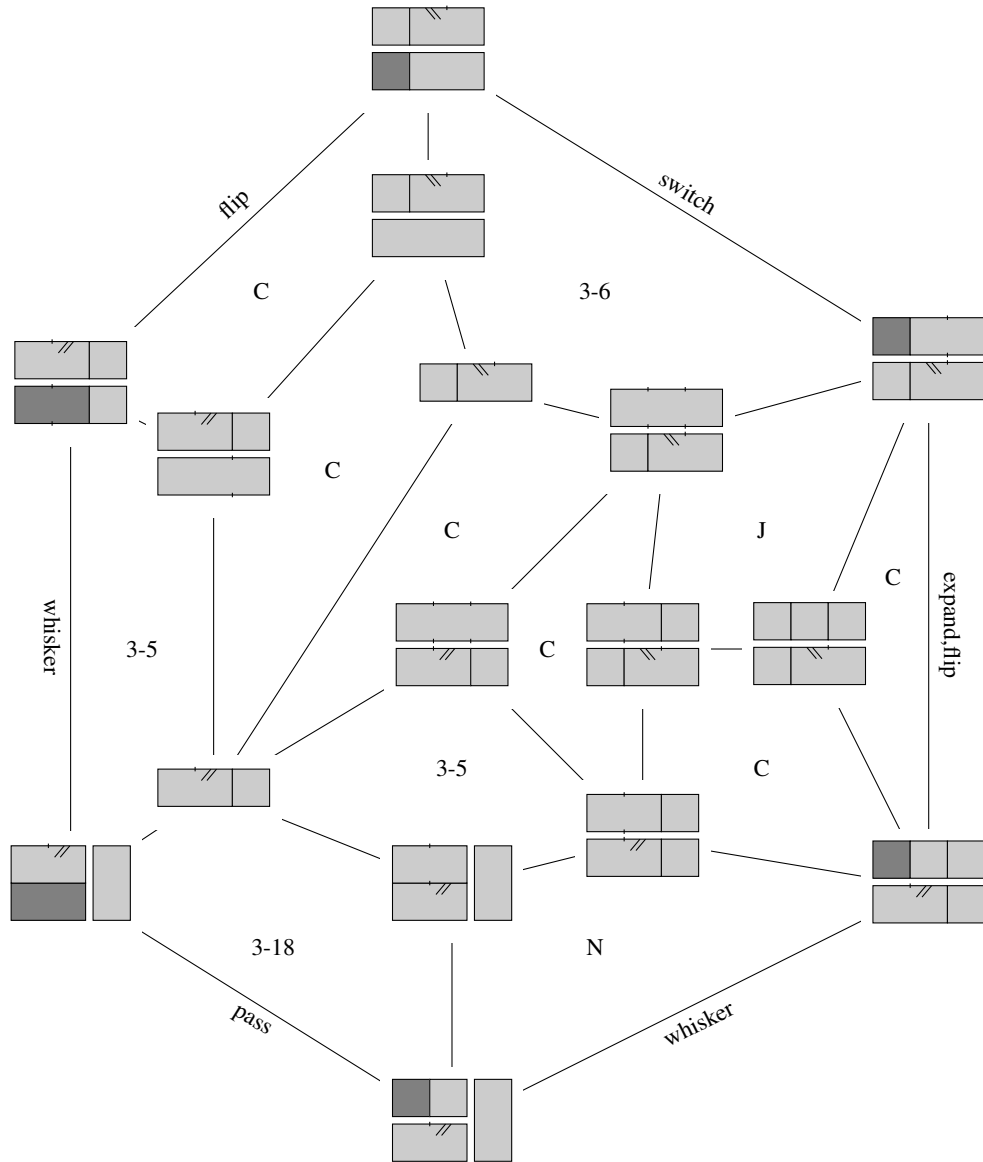

□

Proposition Axiom [3-21] is satisfied.

Proof We can partially fill Axiom [3-21] as follows.

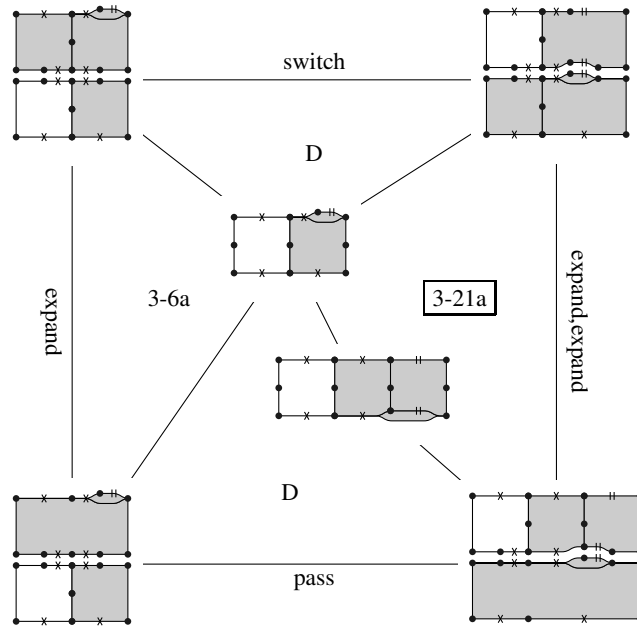

Thus it remains to prove the commutativity of the cell [3-21a]. This is the content of the next Lemma. \square

Lemma Diagram [3-21a] commutes.

Proof Using the corner trick, we can fill in [3-21a] as follows

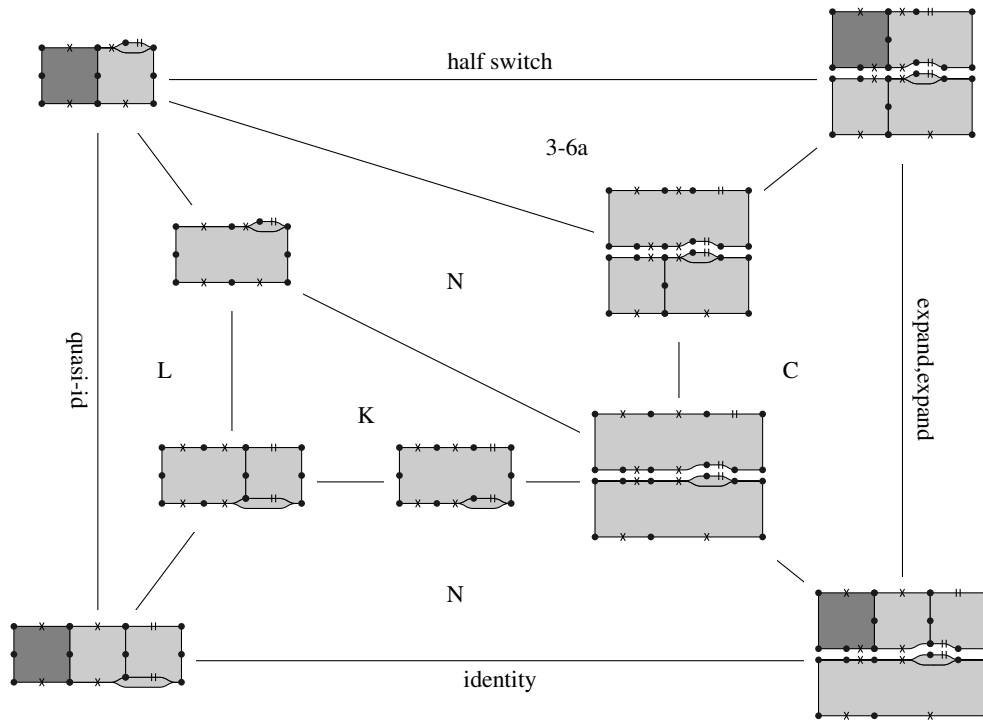

Here we use Lemma L for the first time. It ensures that the cell labeled “L” commutes. The hexagon labeled N at the bottom of the diagram commutes by naturality of the bottom identity with respect to two applications of $1 \boxtimes 1$ -isomorphisms. On one of the sides of this pentagon these two applications of the $1 \boxtimes 1$ -isomorphism are denoted by just one map. \square

Proposition Axiom [3-22] is satisfied.

Proof This follows from this diagram:

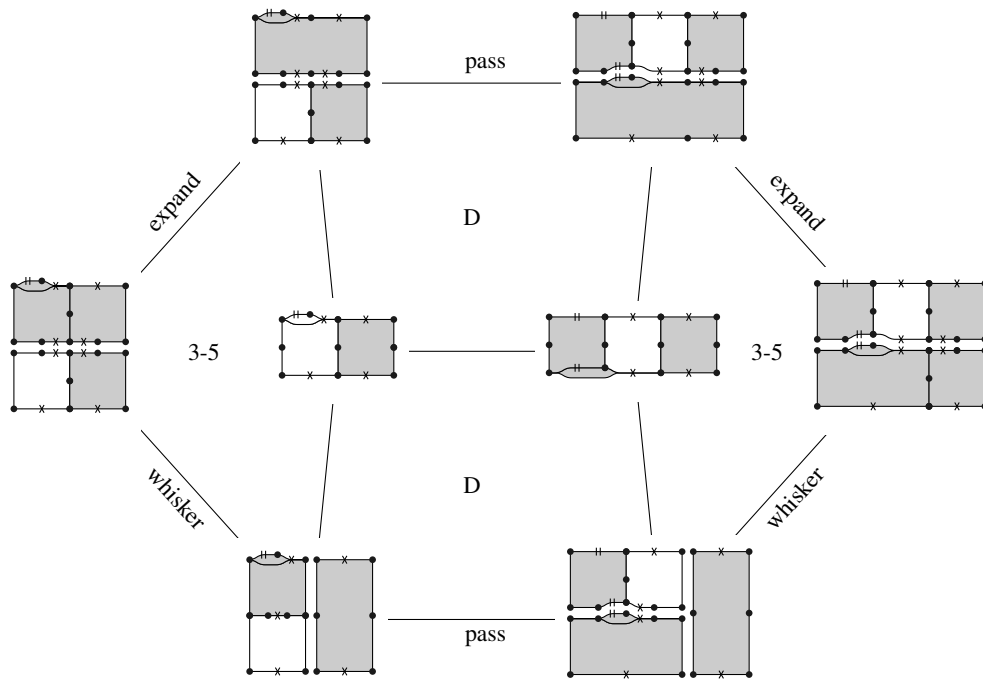

□

Almost all of the axioms of a dicategory object assert that a diagram and a number of variants of the diagram commute. So far we have ignored the variants—their commutativity can always be established by a straightforward variation of the argument for the original diagram. The only exception to this is axiom [3-23]. Here our definition of the swap [2-15] was designed to ensure that [3-23L], the left hand version of [3-23], holds. For the right hand version [3-23R] we will have to use a different argument.

Proposition Axiom [3-23L] is satisfied.

Proof Axiom [3-23L] can be filled as follows:

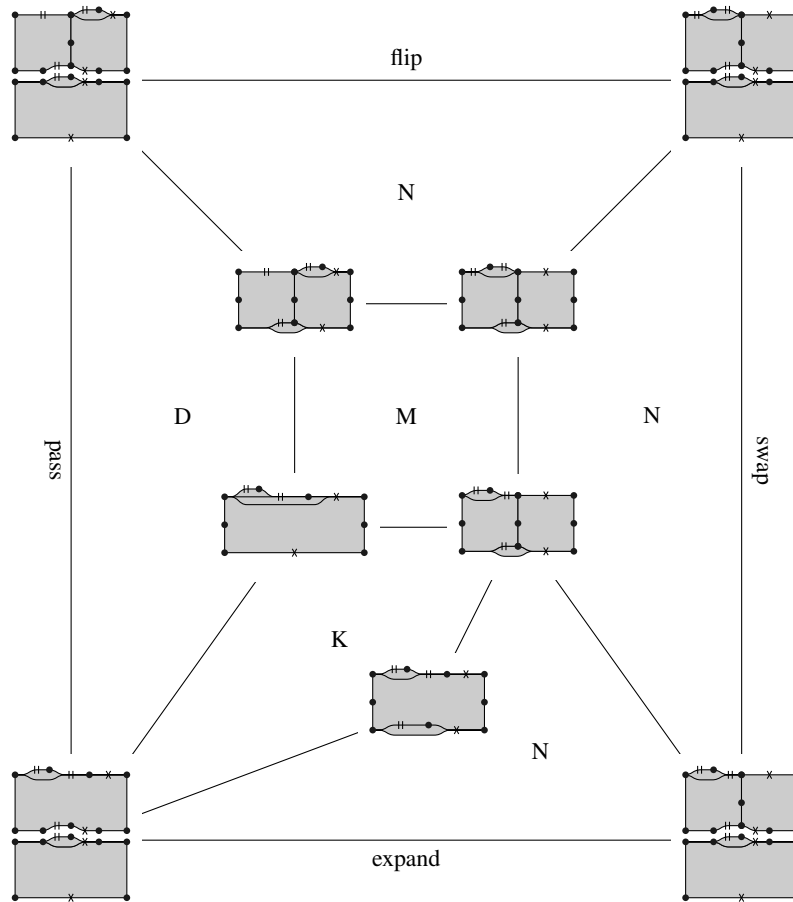

The inner square commutes by Lemma M. □

Proposition Axiom [3-23R] is satisfied.

Proof Consider again the diagram from the proof of [3-23L]. This diagram reduced [3-23L] to Lemma M. The proof of Lemma M in turn reduced to the case where all defects are identity defects. The same argument can be applied to [3-23R] to reduce to the case of identity defects: we therefore only need to prove [3-23R] in the case where

all the defects are identity defects. In this case the following diagram reduces [3-23R] to [3-23L] (which is already proved) and [3-24] (which we prove next):

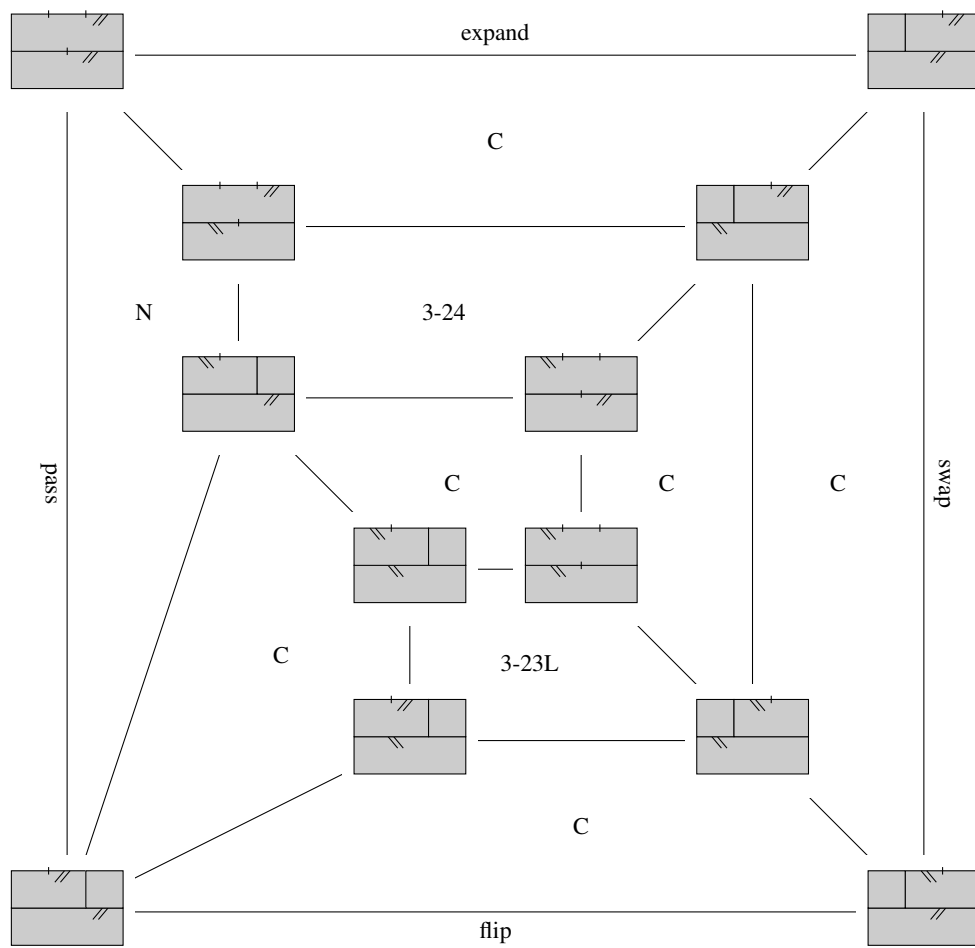

□

Proposition Axiom [3-24] is satisfied.

Proof Axiom [3-24] can be filled as follows:

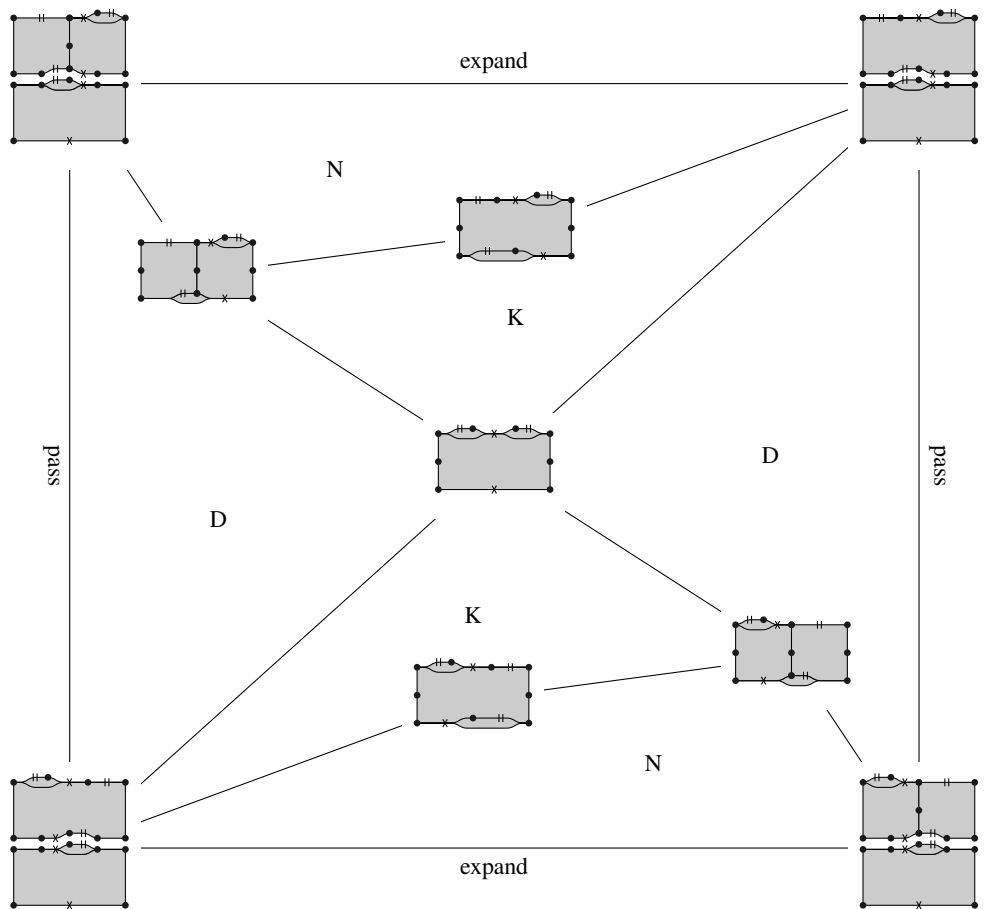

□

Proposition Axiom [3-25] is satisfied.

Proof This follows from the associativity of $1 \boxtimes 1$:

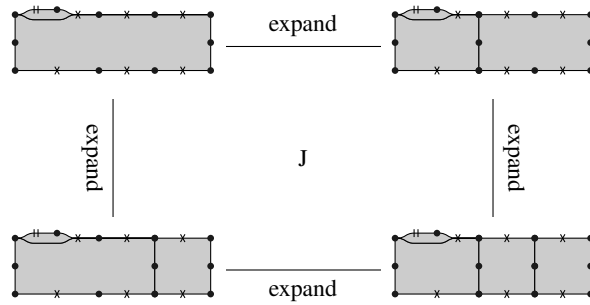

□

Proposition Axiom [3-26] is satisfied.

Proof This follows from the naturality of the flip, applied to the expand isomorphism:

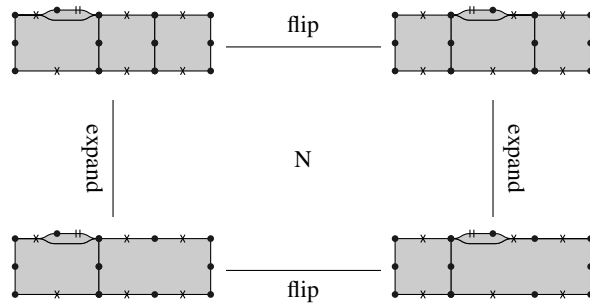

□

Definition ([8, Def. 3.3]) A dicategory object C in the 2-category \mathcal{C} consists of the following three collections of data, subject to the listed axioms.

0-data There are three objects of \mathcal{C} as follows:

- D0-0 : C_0 , a groupoid object, denoted \cdot and called the object of 0-cells.
- D0-1 : C_1 , a groupoid object, denoted --- and called the object of 1-cells.
- D0-2 : C_2 (typically not a groupoid object), denoted $\text{---}\circ\text{---}$ and called the object of 2-cells.

In addition, there are morphisms $s, t : C_1 \rightarrow C_0$ and $s, t : C_2 \rightarrow C_1$, the source and target, such that $st = ss$ and $tt = ts$, and such that $s \times t : C_1 \rightarrow C_0 \times C_0$ and $s \times t : C_2 \rightarrow C_1 \times_{C_0 \times C_0} C_1$ are fibrations.

1-data There are eight 1-morphisms of \mathcal{C} as follows:

- D1-1 : $i : C_0 \rightarrow C_1$, denoted $\text{---}\dashv\text{---}$ and called the 1-cell identity.
- D1-2 : $m : C_1 \times_{C_0} C_1 \rightarrow C_1$, denoted $\text{---}\dashv\text{---}$ and called the horizontal composition.
- D1-3 : $i_v : C_1 \rightarrow C_2$, denoted $\text{---}\text{---}\text{---}$ and called the 2-cell identity.
- D1-4 : $m_v : C_2 \times_{C_1} C_2 \rightarrow C_2$, denoted $\text{---}\text{---}\text{---}$ and called the vertical composition.
- D1-5 : $w_r : C_2 \times_{C_0} C_1 \rightarrow C_2$, denoted $\text{---}\text{---}\text{---}$ and called the right composition or whisker of a 2-cell with a 1-cell.
- D1-6 : $w_l : C_1 \times_{C_0} C_2 \rightarrow C_2$, denoted $\text{---}\text{---}\text{---}$ and called the left composition or whisker of a 1-cell with a 2-cell.
- D1-7 : $i_l : C_1 \rightarrow C_2$, denoted $\text{---}\text{---}\text{---}$ and called the (upper) left 2-cell identity.
- D1-8 : $i_r : C_1 \rightarrow C_2$, denoted $\text{---}\text{---}\text{---}$ and called the (upper) right 2-cell identity.

These morphisms are compatible with source and target maps.

The morphisms [D1-7] and [D1-8] are required to be invertible, in the following sense. There exists a morphism of \mathcal{C} , denoted $\text{---}\text{---}\text{---}$ (the lower left 2-cell identity), such that there are invertible 2-morphisms from $\text{---}\text{---}\text{---}$ to $\text{---}\text{---}\text{---}$ and

from $\text{---}\text{---}\text{---}$ to $\text{---}\text{---}\text{---}$, such that the two resulting 2-morphisms from $\text{---}\text{---}\text{---}$

to $\text{---}\text{---}\text{---}$ are equal, and similarly the two 2-morphisms from $\text{---}\text{---}\text{---}$ to $\text{---}\text{---}\text{---}$ are

equal. Similarly there exists a morphism $\text{---}\text{---}\text{---}$ (the lower right 2-cell identity) satisfying the corresponding conditions.

2-data There are eighteen 2-isomorphisms of \mathcal{C} as follows:

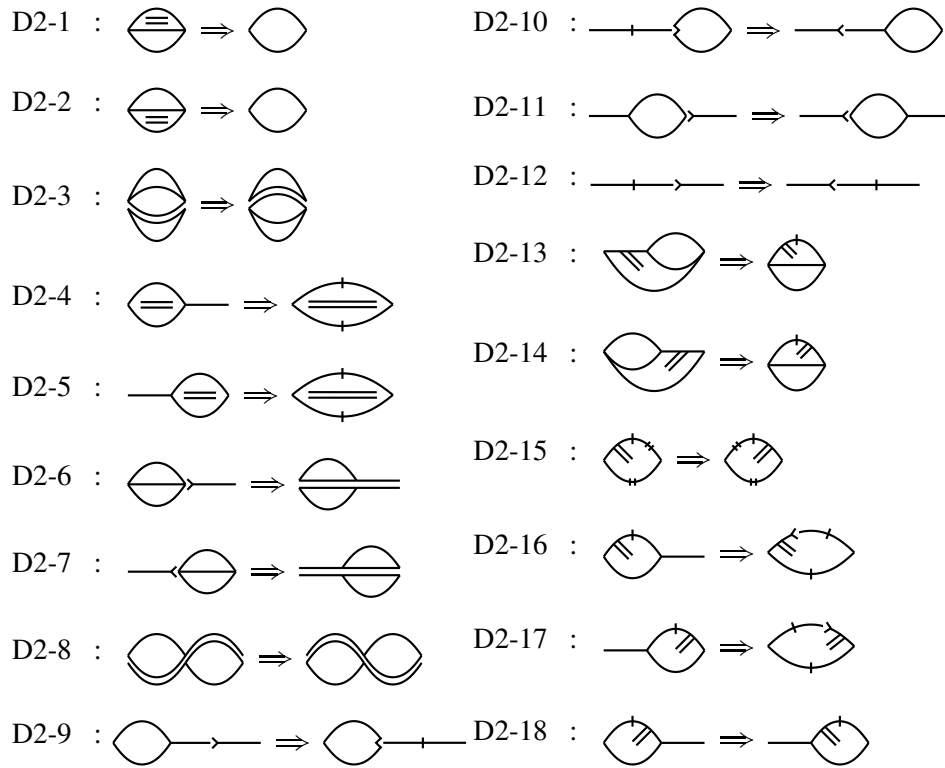

These 2-isomorphisms are compatible with source and target maps in the sense that the sources and targets of [D2-1] through [D2-8] and of [D2-13] through [D2-15] are identity 2-morphisms, the sources and targets of [D2-9] through [D2-11] are the 2-isomorphism [D2-12], the sources of [D2-16] and [D2-18] are [D2-12], the source of [D2-17] is the inverse of [D2-12], and the targets of [D2-16] through [D2-18] are identity 2-isomorphisms.

3-axioms The above data are such that the following twenty-six diagrams, as well as the variant diagrams abbreviated in parentheses, commute:

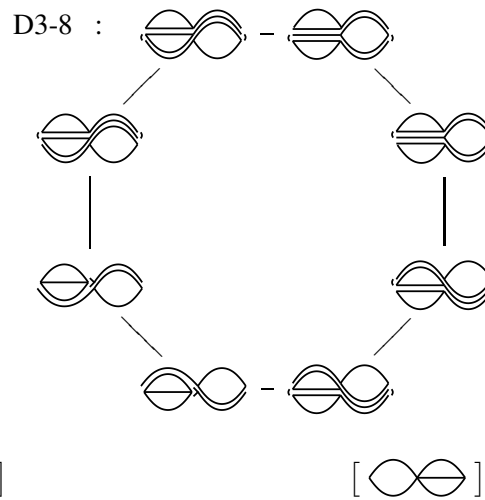
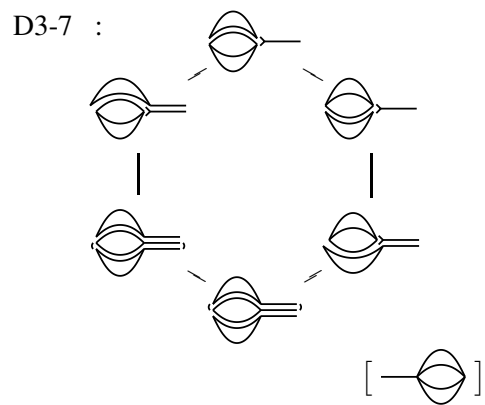
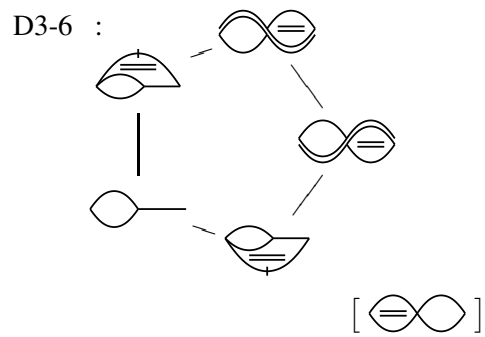
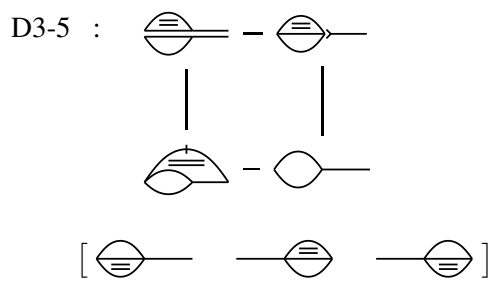
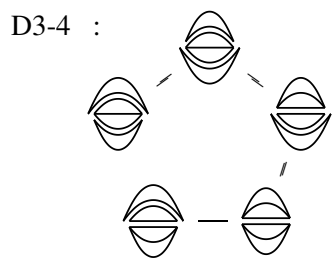
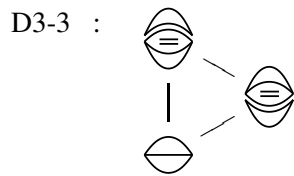
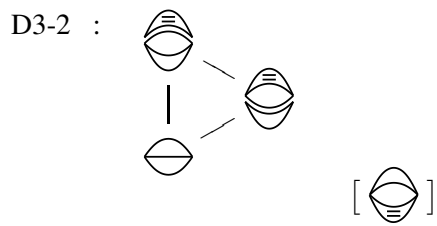

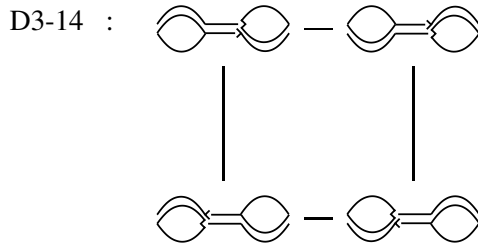
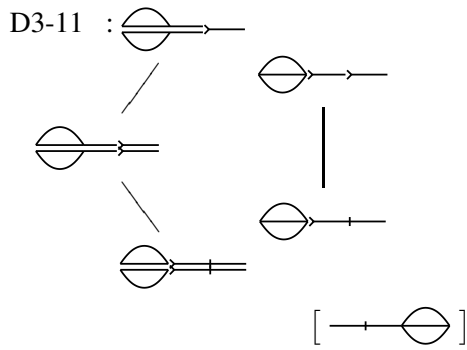
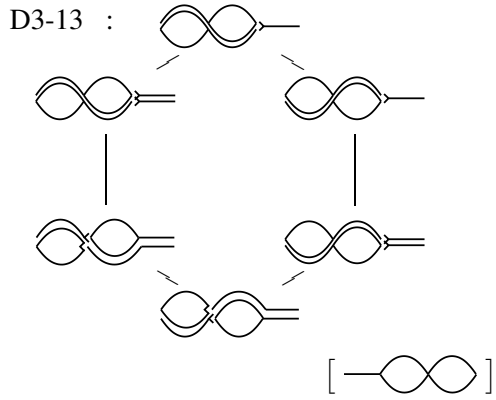
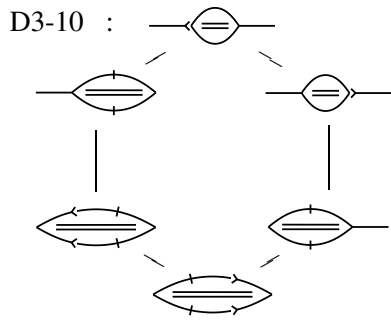
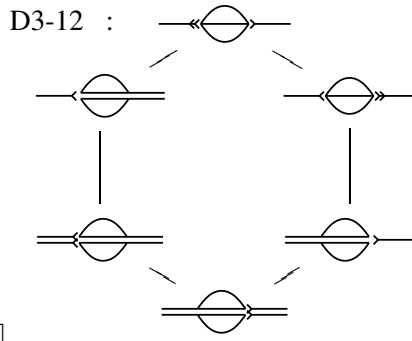
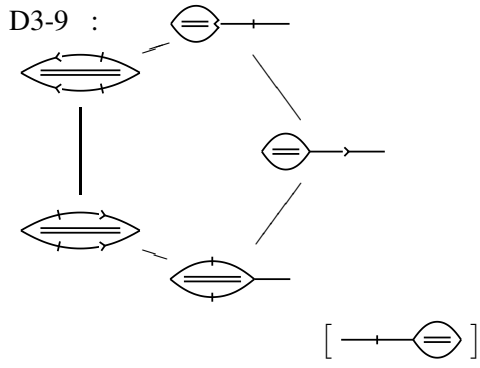

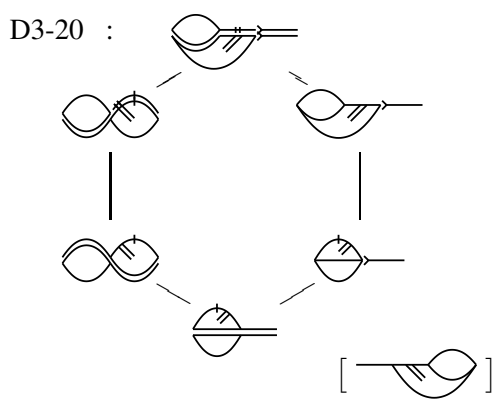
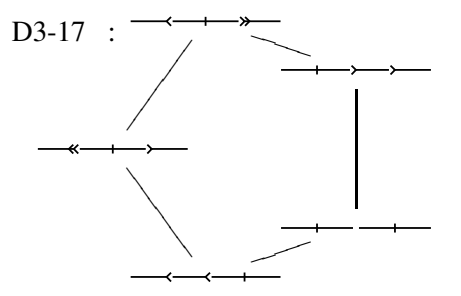
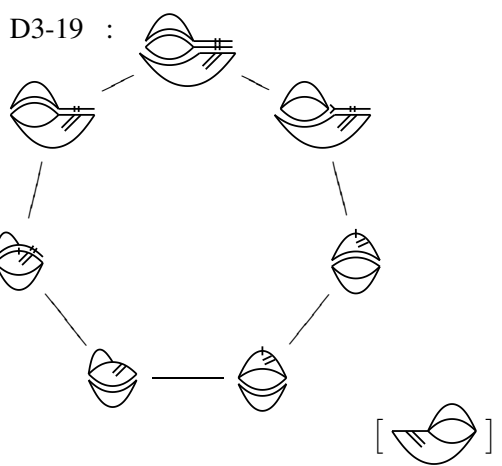
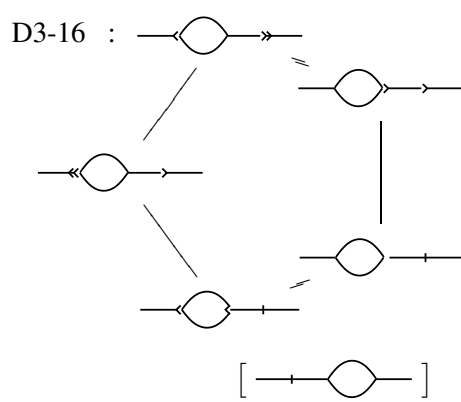
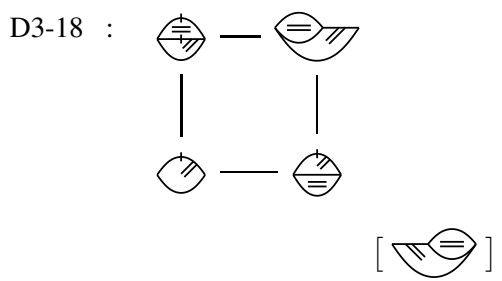
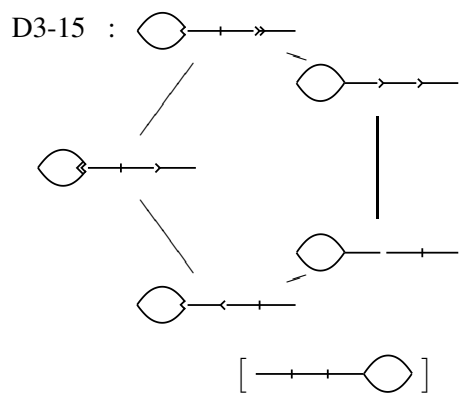

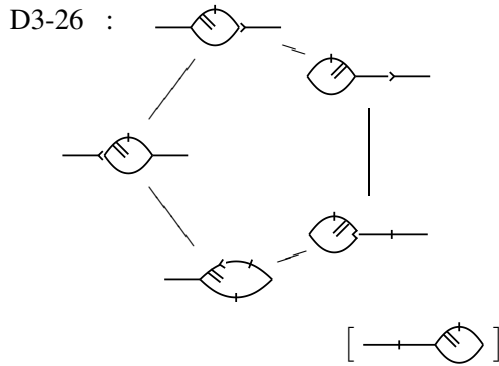
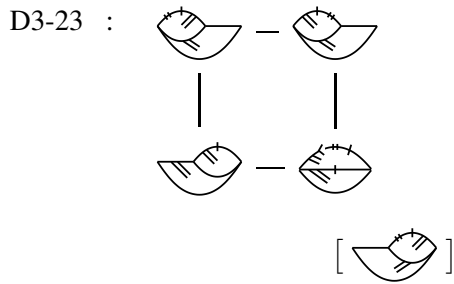
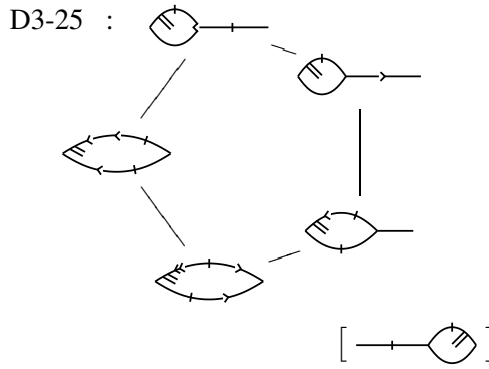
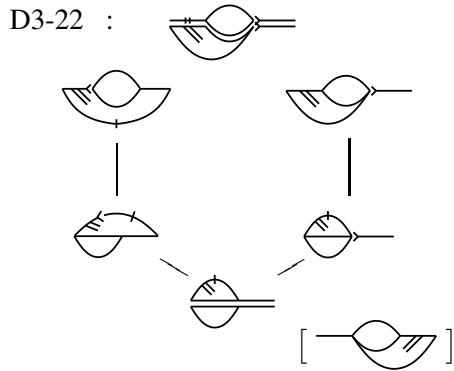
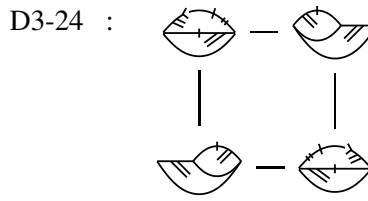
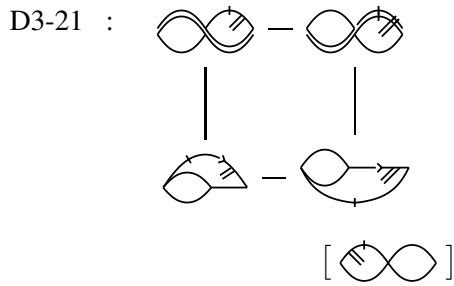

References

- [1] **A Bartels, C L Douglas, A Henriques**, *Conformal nets I: Coordinate-free nets*, Int. Math. Res. Not. 13 (2015) 4975–5052 [arXiv:1302.2604v2](#)
- [2] **A Bartels, C L Douglas, A Henriques**, *Conformal nets II: Conformal blocks*, Comm. Math. Phys. 354 (2017) 393–458 [arXiv:1409.8672](#)
- [3] **A Bartels, C L Douglas, A Henriques**, *Conformal nets III: Fusion of defects*, Mem. Amer. Math. Soc. (2017) [arXiv:1310.8263](#)

- [4] **M Bischoff, Y Kawahigashi, R Longo, K-H Rehren**, *Phase boundaries in algebraic conformal QFT*, Comm. Math. Phys. 342 (2016) 1–45
- [5] **R Brunetti, D Guido, R Longo**, *Modular structure and duality in conformal quantum field theory*, Comm. Math. Phys. 156 (1993) 201–219
- [6] **D Buchholz, G Mack, I Todorov**, *The current algebra on the circle as a germ of local field theories*, Nuclear Phys. B Proc. Suppl. 5B (1988) 20–56
- [7] **D Buchholz, H Schulz-Mirbach**, *Haag duality in conformal quantum field theory*, Rev. Math. Phys. 2 (1990) 105–125
- [8] **C L Douglas, A Henriques**, *Internal bicategories* (2012) [arXiv:1206.4284](https://arxiv.org/abs/1206.4284)
- [9] **F Gabbiani, J Fröhlich**, *Operator algebras and conformal field theory*, Comm. Math. Phys. 155 (1993) 569–640
- [10] **Y Kawahigashi, R Longo**, *Classification of local conformal nets. Case $c < 1$* , Ann. of Math. (2) 160 (2004) 493–522
- [11] **Y Kawahigashi, R Longo, M Müger**, *Multi-interval subfactors and modularity of representations in conformal field theory*, Comm. Math. Phys. 219 (2001) 631–669
- [12] **J N Mather**, *Commutators of diffeomorphisms*, Comment. Math. Helv. 49 (1974) 512–528
- [13] **A Wassermann**, *Operator algebras and conformal field theory. III. Fusion of positive energy representations of $LSU(N)$ using bounded operators*, Invent. Math. 133 (1998) 467–538

Westfälische Wilhelms-Universität Münster, Mathematisches Institut, Einsteinstr. 62, D-48149 Münster, Deutschland

Mathematical Institute, Radcliffe Observatory Quarter, Woodstock Road, Oxford, OX2 6GG, United Kingdom

Mathematisch Instituut, Universiteit Utrecht, Postbus 80.010, 3508 TA Utrecht, The Netherlands

bartelsa@wwu.de, cdouglas@maths.ox.ac.uk, a.g.henriques@uu.nl