

Development of the superconducting detectors and read-out for the X-IFU instrument on board of the X-ray observatory Athena

L. Gottardi^{a,*}, H. Akamatsu^a, M. Bruijn^a, R. den Hartog^a, J.-W. den Herder^a, B. Jackson^a, M. Kiviranta^b, J. van der Kuur^a, H. van Weers^a

^aSRON Netherlands Institute for Space Research, Utrecht, The Netherlands

^bVTT, Espoo, Espoo, Finland

Abstract

The Advanced Telescope for High-Energy Astrophysics (Athena) has been selected by ESA as its second large-class mission. The future European X-ray observatory will study the hot and energetic Universe with its launch foreseen in 2028. Microcalorimeters based on superconducting Transition-edge sensor (TES) are the chosen technology for the detectors array of the X-ray Integral Field Unit (X-IFU) on board of Athena. The X-IFU is a 2-D imaging integral-field spectrometer operating in the soft X-ray band (0.3 – 12 keV). The detector consists of an array of 3840 TESs coupled to X-ray absorbers and read out in the MHz bandwidth using Frequency Domain Multiplexing (FDM) based on Superconducting QUantum Interference Devices (SQUIDs). The proposed design calls for devices with a high filling-factor, high quantum efficiency, relatively high count-rate capability and an energy resolution of 2.5 eV at 5.9 keV. The paper will review the basic principle and the physics of the TES-based microcalorimeters and present the state-of-the art of the FDM read-out.

Keywords: Transition Edge Sensor, Frequency Domain Multiplexing, Athena Mission, X-IFU

PACS: ,

1. Introduction

The Advanced Telescope for High-ENergy Astrophysics (*Athena*) will be an X-ray telescope designed to address the Cosmic Vision science theme 'The Hot and Energetic Universe' and its launch is foreseen in 2028. It will answer important science questions like[1]:

- How does ordinary matter assemble into the large-scale structures we see today?
- How do black holes grow and shape the Universe?

Thanks to its revolutionary optics technology and to the most advanced X-ray instrumentation, Athena will have superior wide field X-ray imaging, timing and imaging spectroscopy capabilities, far beyond those of any existing observatory. The X-ray Integral Field Unit (X-IFU) is one of the two instrument on board of Athena. It is a 2-D imaging integral-field spectrometer operating in the soft X-ray band (0.2 – 12 keV). It will provide breakthrough capabilities for mapping in 3D the hot cosmic gas to study for example the process of matter assembly in clusters and for detecting weak lines to characterise the metals in clusters of galaxies or the missing baryons in the Warm-Hot Intergalactic Medium [2]. The X-IFU proposed design calls for devices with an high filling-factor, high quantum efficiency,

relatively high count-rate capability and energy resolution better than 3 eV at 5.9 keV. The major requirements for the X-IFU instrument are listed in Tab. (1). Arrays of microcalorimeters

Parameters	Requirements
Energy range	0.2 – 12 keV
Energy resolution: $E < 7$ keV	2.5 eV
Pixel size	$250 \times 250 \mu\text{m}^2$
Field of view	5' (diameter)
Quantum efficiency @ 6 keV	> 90%
Count rate - faint source	1 mCrab (> 80% high-resolution)
Count rate - bright source	1 Crab (> 30% low-resolution)
non X-ray background	$(< 5 \times 10^{-3} \text{ cts/cm}^2/\text{keV})$

Table 1: Key performance requirements for X-IFU

based on superconducting transition-edge sensors (TES) and Frequency Domain Multiplexing (FDM) read out are the chosen technologies to achieve these ambitious requirements. A TES based anti-coincidence detector will be an essential part of the instrument as well needed to disentangle fake signals produced by high-energy particles. TES arrays have been used as radiation detectors in a large variety of wave lengths, from 3-5 mm (as in the CMB experiments [3]) up to gamma ray [4].

The X-IFU detector, under development at SRON/VTT and GSFC/NIST, consists of an array of 3840 TES-based mi-

*Corresponding author

Email address: l.gottardi@sron.nl (L. Gottardi)

calorimeters read out by Superconducting QUantum Interference Devices (SQUIDs) using 96 channels of 40 pixels each multiplexed in frequency domain in the MHz bandwidth. The anti-coincidence detector is part of the X-IFU focal plane assembly and it is currently under development at INAF/IAPS-Roma and INFN-Genova [5].

2. The TES based detectors

TES based devices are thermal equilibrium detectors where the incoming energy is absorbed and converted into equilibrium excitations [6]. They generally consist of a very sensitive thermometer coupled to an efficient radiation absorber. The thermometer is made of a superconducting film operated in the sharp transition between the normal and the superconducting state where the film resistance varies between zero and its normal value, typically of the order of tenths to hundredths of $m\Omega$. A TES is generally made of thin film superconducting bi-layer like TiAu, MoAu or MoCu deposited on a SiN thin membrane. The critical temperature T_c can be accurately chosen by exploiting the proximity effect between the superconducting (Ti,Mo) and normal (Au,Cu) materials.

The TES variable resistance is part of a superconducting bias circuit. The increase of the detector temperature caused by the absorbed radiation leads to an increase of the TES resistance which is measured as a reduction of the bias current. Voltage biasing of a TES leads to so-called electro-thermal feedback (ETF) [7] which counteracts excursions from the set point. ETF increases the thermal response speed and linearises the output signal. Biasing can be realised using a dc-voltage source or using an ac-source (as in the case of FDM)[8]. Typical operation temperatures are around 100 mK. TES based detectors can be operated as bolometers to measure power or as calorimeters to detect energy of single photons. Extremely high sensitivity has been demonstrated with single pixels: for example, a dark Noise Equivalent Power of $\sim 1 \cdot 10^{-19} \text{ W}/\sqrt{\text{Hz}}$ with TiAu TES bolometers fabricated at SRON [9] and an energy resolution of 1.58 eV at 6 keV with MoAu TES micro-calorimeters fabricated at NASA-GSFC [10].

When operating as a microcalorimeter for soft X-ray spectroscopy, like in the X-IFU instrument, the TESs are strongly thermally coupled to a free hanging absorber designed to optimize the quantum efficiency and the filling factor in a pixels array. The TES-absorber system is weakly coupled to the thermal bath via thermal conductance G . A schematic diagram of a TES microcalorimeter pixel and an optical micro-graph of a 32×32 pixels array under development at SRON are shown in figure 1.

The energy E_o deposited by a photon in the absorber with heat capacity C increases the detector temperature of $\Delta T = E_o/C$. The temperature excursion will then decay exponentially back to equilibrium with a time constant $\tau = C/G$. The sensitivity of a TES microcalorimeter is limited by the thermodynamic energy fluctuations present in the system. In the small signal limit and in the case of strong ETF, considering just the thermal-fluctuation and the TES Johnson noise, the FWHM energy resolution can be approximated as

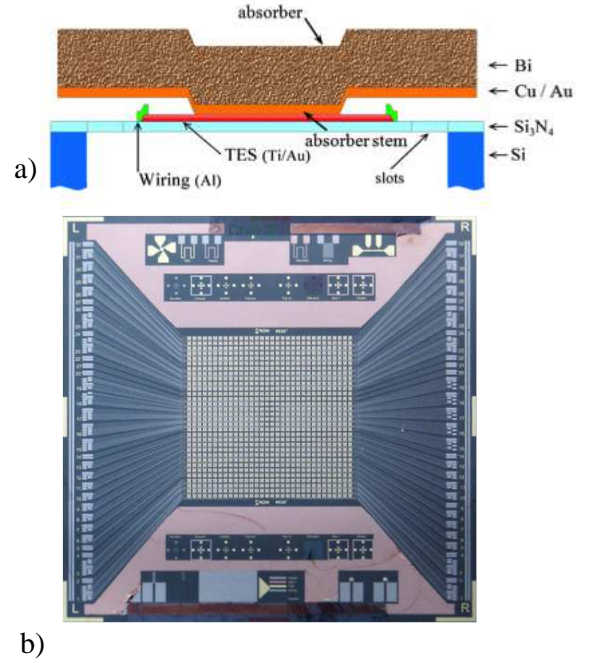

Figure 1: **a)** Cross section of a single pixel TES microcalorimeter. **b)** a 32×32 TES array fabricated at SRON

$\Delta E_{FWHM} = 2.335 \sqrt{4k_b T_c^2 \frac{C}{\alpha} \sqrt{1 + 2\beta}}$, where the two parameters $\alpha = T/R \partial R / \partial T$ and $\beta = I/R \partial R / \partial I$ describe the dependency of the TES resistance on temperature T and current I [6]. It becomes clear then that to achieve high energy resolution one should operate the detector at low temperature, using low heat capacitance absorber material and a TES with a steep resistive transition (high α) and a low current dependence (small β). One should be aware however that a small heat capacitance and a steep transition can be achieved at the cost of a reduced detector dynamic range. An optimisation of the parameters exists as described in [11]. Typical parameters for TES microcalorimeter are: $T_c \sim 100 \text{ mK}$, $C(100 \text{ mK}) \sim 0.5 \text{ pJ/K}$, $\alpha \sim 50 - 100$ and $\beta \sim 0.2 - 1$.

In spite of the fact that TES detectors have been developed for more than two decades now and are operational in many instruments, the fundamental physics that describe these devices has only been recently better understood. It has been observed that TES devices behave as superconducting weak-links due to the longitudinally induced superconductivity from the superconducting Nb leads via the proximity effect [12]. The dependence on the perpendicular magnetic field coupled into the TES has also been thoroughly investigated only in the few past years [13]. By applying the standard resistively shunted model developed for Josephson junctions and superconducting weak links [14], it is possible to calculate the resistive transition $R(T,I)$ of a TES [15]. In figure 2 the model of the resistive transition for a TiAu TES bolometer developed at SRON [16] is shown. The Josephson current has been directly observed in TES-bolometers operating in a frequency domain multiplexer and biased by ac voltage at MHz frequencies [16]. The recent development in understanding the physics of the TES's is con-

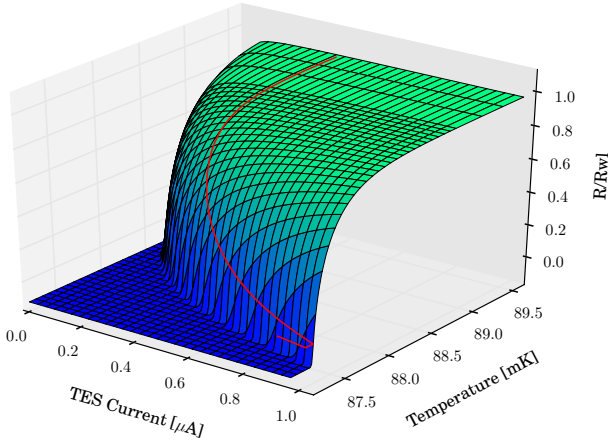

Figure 2: Resistive transition $R(T, I)$ of a TES bolometer fabricated at SRON calculated using the resistively shunted junction model.

sidered as an important step forward in the optimisation of the performance of a single pixel and a large array of pixels.

The pixels array for X-IFU, based on MoAu TES's and Au-Bismuth absorbers is currently under development at NASA-Goddard [17]. SRON is developing the back-up array using TiAu film technology.

3. The Frequency Domain Multiplexing

The limited cooling power available on a space-based instrument and the harness complexity makes the readout of each individual pixel of the array by its own SQUID amplifier impossible and SQUID multiplexer schemes such as time domain multiplexing (TDM) [18] and FDM are being developed. TDM is the most mature technology at the moment [17], however FDM has potentially several important advantages over TDM such as a better use of the available bandwidth resulting in a larger multiplexing factor, a smaller thermal load on the cooling chain and an easier implementation of the cold electronics on the focal plane assembly.

SRON-VTT is developing the Frequency Domain Multiplexing and the SQUID read-out for the X-IFU microcalorimeters array. FDM requires amplitude modulation of the TES signal, which can be achieved by biasing the microcalorimeter with an ac voltage source. Changes of the TES resistance modulate the amplitude of the ac bias current, following the thermal signal. In practice the TES signal is moved up to a frequency band around the carrier signal which is typically in the range between 1 and 5 MHz. Each pixel is separated in the frequency space by high- Q superconducting LC filters [19] connected in series with the TES resistance. The current through each TES is coupled to the SQUID amplifier input coil through a superconducting summing point. The multiplexing factor depends on the available read-out bandwidth and the detector signal speed. For slow detectors like the low-G bolometers under development at SRON for the future infrared space mission [20] a multiplexing factor of 160 pixels per SQUID channel has been shown [21]. For the faster X-ray microcalorimeters the current baseline X-IFU

design calls for a multiplexing factor of 40 pixels per SQUID channel which implies a separation of 100 kHz between each pixel in a read-out bandwidth between 1 to 5 MHz[22].

To improve the limited SQUID dynamic range baseband feedback (BBFB) [23] is used to cancel the signal at the sum-point. The signal at the output of the room temperature low noise amplifier (LNA) is demodulated by digital electronics to extract the signal information from the TES, re-modulated and fed back to the SQUID feedback coil. The X-IFU instruments read-out requires SQUID amplifiers with low input inductance, low flux noise, high-dynamic range and low power consumption. We have recently demonstrated nearly quantum-limited sensitivity with the two-stage SQUIDs amplifiers developed at VTT and optimised for the read-out of large array of infrared bolometers and X-ray microcalorimeters. We measured an open-input flux noise at $T = 25\text{mK}$ equal to $1.8 \cdot 10^{-7} \Phi_0 / \sqrt{\text{Hz}}$ and an input current noise of $1\text{pA} / \sqrt{\text{Hz}}$, which corresponds to a coupled energy resolution of $\epsilon_{fi} = 15\hbar$ over the whole interesting frequency range from 2 to 5 MHz [24].

An FDM prototype with 13 active resonators coupled to a NASA-Goddard TES 8x8 array is shown in figure 3

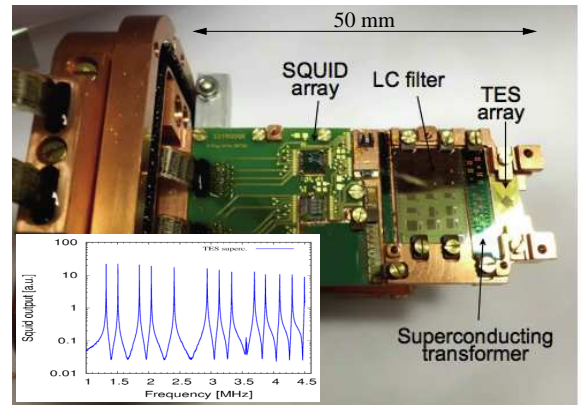

Figure 3: Picture of an FDM prototype with VTT two-stage SQUID amplifiers, lithographic LC filters and a NASA-Goddard TES microcalorimeter array. Inset: SQUID output with 13 active resonators.

An extended study of the single pixel performance under MHz bias of the NASA-Goddard TES microcalorimeters[25] is on going at SRON [26]. We have shown an X-ray energy resolution of $2.7 \pm 0.2 \text{ eV}$ and $2.8 \pm 0.2 \text{ eV}$ at 5.9 keV with single pixels read out respectively at a frequency of 2.3 and 3.7 MHz [27]. We are currently optimising a prototype for the first FDM demonstration of GSFC array up to 18 pixels. The first demonstration model for the X-IFU instrument with 40 pixels multiplexing and 4 SQUID channels read-out is scheduled for the coming year.

4. The Focal Plane Assembly

Another challenging development for the X-IFU instrument is the design and fabrication of the Focal Plane Assembly (FPA) which hosts at a temperature of 50mK a large-format array of TES's, a large array of lithographic LC filters, a large amount of SQUID amplifiers and the TES based anti-coincidence detector.

The FPA is suspended from a temperature level of 1.7K to 2K, with an additional thermal interface at an intermediate temperature of 0.3K. Key-technologies are under development such as magnetic shielding, high density superconducting interconnects and thermal insulating suspension. A cross-section of the FPA is shown in figure 4 together with a picture of the mechanical assembly of the Nb shield. A detailed description of the FPA development can be found in [28]. The magnetic shielding de-

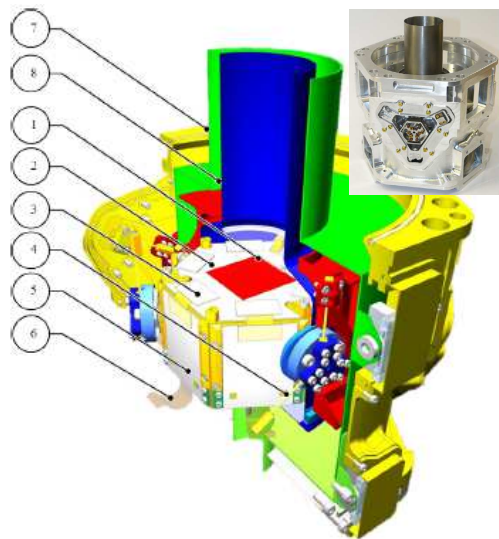

Figure 4: FPA cross section with (1) TES array; (2) TES wafer; (3) TES wafer to cold electronics unit interconnect; (4) Kevlar thermal insulating suspension of 50 mK stage to the 300 mK stage; (5) cold electronics unit carrying LC resonators, bias networks and first stage SQUIDS; (6) Signal flex cable to higher temperature stage; (7) High permeability Cryoperm 10 magnetic shield; (8) Niobium superconducting magnetic shield. Inset: Picture of the Nb shield and its mechanical assembly

sign is driven by the following two requirements: the absolute static normal magnetic field component over the TES array is less than 10^{-6} T and the maximum normal magnetic field noise over the TES array is less than $0.2\text{nT}/\sqrt{\text{Hz}}$. This implies having a magnetic shielding factor as large as 10^5 over the whole array size. An on-axis shielding factor exceeding 10^6 has been measured in a demonstrator with a combination of cryoperm and Nb shields. [28].

We are currently developing a novel superconductive technology for the interconnection between the TES array and the cold electronics using transformed based coil coupling, an unique feature of the frequency domain read-out. If proven successful this technique will allow high-density connections and easy replacement of the pixels array during the development and engineering phase of this very complicated space instrument. In the current design each pixel is fanned-out to a superconducting coil at the edge of the TES wafer. The mating interconnect pieces contain the secondary coils which form a transformer once assembled. They are fabricated by spinning and patterning of polyimide on a Si wafer after that Nb tracks are deposited using standard lithographic processing. In a final DRIE step the interconnect are etched from the rest of the Si wafer leaving a flexible free standing membrane [28].

The mechanical support of the detector stage and the 300 mK level has to fulfil stringent requirements on position stability of the detector array over multiple cool downs, compactness in terms of space, modularity in assembly and sufficient thermal isolation between the stages. A kinematic suspension design using Kevlar cords have been chosen and is currently under development and test [28].

5. Conclusion

Athena has been selected by ESA as its second large-class mission. The future European X-ray observatory will study the hot and energetic Universe with its launch foreseen in 2028. Microcalorimeters based on superconducting Transition-edge sensor (TES) are the chosen technology for the detectors array of the X-IFU instrument on board of *Athena* SRON/VTT, GSFC/NIST and INAF(Italy) are developing the first demonstration model for the X-IFU instrument with 40 pixels multiplexing and 4 SQUID channels read-out and the anti-coincidence detector. The extended activities include the fabrication and the testing of the large array of high energy resolution X-ray TES microcalorimeter, the cold electronics for the frequency domain multiplexing, the TES based anti-coincidence detector and the key-technologies for the focal plane assembly.

Acknowledgements

H.A. was supported by a Grant-in-Aid for Japan Society for the Promotion of Science (JSPS) Fellows (22-606)

References

- [1] X. Barcons, et al., J. Phys:Conf.Ser 610 (2015) 012008
- [2] L. Ravera, Proc. SPIE 9144, (2014) 91442L.
- [3] *List of cosmic microwave background experiments*, Wikipedia, The Free Encyclopedia, (2015).
- [4] D. Bennett, et-al., Rev. Sci. Instr. 83 9 (2012) 093113.
- [5] C. Macculli, et-al, Proc. SPIE 9144, (2014) 91445S.
- [6] Ch. Enss, Cryogenic Particle Detection (Springer-Verlag,2005)
- [7] K. Irwin, Appl. Phys. Lett. 66 (1995) 1998.
- [8] J. van der Kuur, et al., Nucl. Instr. Methods Phys. Res. A 520 (2004) 551.
- [9] T. Suzuki to be published
- [10] S. J. Smith, et al., J. Low Temp. Phys. 167 (2012) 168-175.
- [11] J. N. Ullom, et al, Appl. Phys. Lett., 87 (2005) 194103.
- [12] J. Sadleir, et al, Phys. Rev. B 84 (2011) 184502.
- [13] S. J. Smith, et al., J. Appl. Phys. 114 (2013) 074513.
- [14] K. Likharev, Rev. Mod. Phys. 51, (1979) 101.
- [15] A. Kozorezov, et al., Appl. Phys. Lett. 99 (2011) 063503.
- [16] L. Gottardi, et al., Appl. Phys. Lett. 105 (2014) 162605.
- [17] S. J. Smith, et al., IEEE Trans. Appl. Superc. (2015).
- [18] W. B. Doriese, et al, J. Low Temp. Phys 167 (2012) 595-601.
- [19] M. Bruijn, et al., J. of Low Temp. Phys. 167 (2012) 695700
- [20] P. Roelfsema, Proc. SPIE 9143 (2014) 91431K.
- [21] R. A. Hijmering, Proc. SPIE. 9153 (2014) 91531E.
- [22] R. H. den Hartog, et al., Proc. SPIE 9144 (2014) 91445Q .
- [23] R. den Hartog, et al., AIP Conf. Proc. 1185 (2009) 261
- [24] L. Gottardi, et al., IEEE Trans. Appl. Superc. (2015).
- [25] N. Iyamoto, et al., Appl. Phys. Lett. 92 (2008) 13508 and S. R. Bandler, et al., J. Low Temp. Phys. 151 (2008) 400405
- [26] H. Akamatsu, et al., J. of Low Temp. Phys.,(2014) 16
- [27] H. Akamatsu, et al., to be published in J. of Low Temp Phys.
- [28] H. J. van Weers, et al., Proc. SPIE 9144 (2014) 91445R and A. Bergen, et al., submitted to RSI (2015)