

# Black Hole Firewalls Require Huge Energy of Measurement

Masahiro Hotta and Jiro Matsumoto

*Department of Physics, Faculty of Science, Tohoku University,  
Sendai 980-8578, Japan*

Ken Funo

*Department of Physics, University of Tokyo, 7-3-1 Hongo,  
Bunkyo-ku, Tokyo 113-0033, Japan*

## Abstract

The unitary moving mirror model is one of the best quantum systems for checking the reasoning of the original firewall paradox of AMPS in quantum black holes. Though the late-time part of radiations emitted from the mirror is fully entangled with the early-part, no firewall exists with a deadly, huge average energy flux in this model. This is because high-energy entanglement structure of the discretized systems in almost maximally entangled states is modified so as to yield the correct description of low-energy effective field theory. Furthermore, the strong subadditivity paradox of firewalls is resolved using non-locality of general one-particle states and zero-point fluctuation entanglement. Due to the Reeh-Schlieder theorem in quantum field theory, another firewall paradox is inevitably raised with quantum remote measurements in the model. We resolve this paradox from the viewpoint of the energy cost of measurements. No firewall appears, as long as the energy for the measurement is much smaller than the ultraviolet cutoff scale.

# 1 Introduction

The firewall paradox [1] of quantum black holes poses a profound question about the relation between quantum information and quantum gravity. With the advent of AdS/CFT [2], black hole evaporation processes are now widely believed to be unitary [3]. It seems likely that all information stored in the interior of a black hole may be imprinted into outside radiation and eventually released to the spatial infinity. Superficially, this process may be accompanied by a quantum-cloning-like mechanism to generate the informative radiation. However, invoking the concept of black hole complementarity [4] saves the no-cloning theorem [5]. Simultaneously, the complementarity maintains the semiclassical picture in which a free-falling observer experiences nothing out of the ordinary when crossing the horizon. However, Almheiri et al. (AMPS) recently argued [1] that the absence of drama for the infalling observer contradicts the following natural postulates as follows:

Postulate 1: The process of formation and evaporation of a black hole, as viewed by a distant observer, can be described entirely within the context of standard quantum theory. In particular, there exists a unitary  $S$  matrix that describes the evolution from infalling matter to outgoing Hawking-like radiation.

Postulate 2: Outside the stretched horizon of a massive black hole, physics can be described to a good approximation by a set of semiclassical field equations.

Assuming Postulates 1 and 2, AMPS analyze the entanglement ability of gaining information about late-time radiation for a sufficiently old black hole via measurements of early-time radiation. They then conclude that infalling observers will encounter high-average-energy modes of the late-time radiation and burn up at the horizon. Because of Postulate 1, the final state  $|\Psi\rangle$  of black hole evaporation is assumed to be pure. They divide the system into an early radiation part  $E$  and a late radiation part  $L$ . It is assumed that there is a natural UV cutoff in the black hole physics and that the Hilbert spaces of  $E$  and  $L$  have finite discrete dimensions  $N_E$  and  $N_L$ . Using an arbitrary complete basis  $\{|i\rangle_L\}$  for  $L$  of an old black hole with  $N_E > N_L$ , the final

state  $|\Psi\rangle$  can be expanded as:

$$|\Psi\rangle = \sum_{i=1}^{N_L} |\psi_i\rangle_E |i\rangle_L, \quad (1)$$

where  $|\psi_i\rangle_E$  is an unnormalized state of  $E$ . Using the same philosophy of typical-state entanglement [6, 7, 8], one can argue that  $L$  is fully entangled with  $E$  in the state  $|\Psi\rangle$ . Thus, AMPS assume that a measurement of  $E$  outputting a result  $i$  exists such that the post-measurement state of  $L$  is nearly equal to an arbitrarily fixed  $|i\rangle_L$ . In particular, a measurement of the number of outgoing  $L$  particles may be expected, in which  $|i\rangle_L$  becomes a number eigenstate of the particles. Going back in time, the particles in state  $|i\rangle_L$  are present near the horizon and severely blueshifted by the strong gravitational force. Each particle carries quite a huge amount of energy—much larger than the Hawking temperature of the black hole. Thus AMPS expects that the energy expectation value of the particles also becomes divergent. This high-average-energy flux of the mode near the horizon is referred to as a *firewall*. It is also stressed that the real execution of the measurement is not needed for firewalls [10][27]. In the argument, the existence of almost maximal entanglement between  $E$  and  $L$  is essential. Because the reduced density operator of  $L$  becomes an almost maximally entropic state,

$$\mathrm{Tr}_E [|\Psi\rangle\langle\Psi|] \sim \frac{1}{N_L} \sum_i |i\rangle_L \langle i|_L = \frac{1}{N_L} \mathbf{I}_L$$

it is concluded that typical states with firewall singularity are dominant in the calculation of expectation values of the particle number and the energy momentum tensor. Let us imagine Alice in a free-fall motion tries to get across the horizon. Then, irrespective of whether the firewall observation requires a measurement of  $E$ , she will encounter the firewall with near certainty before she passes over the horizon and burns out, as long as AMPS's argument is correct. This firewall scenario is completely different from the complementarity scenario [4], in which Alice is able to safely traverse the horizon.

Exactly as in Ref. [11], AMPS also restate this firewall conjecture from an information theoretical point of view. Let  $A$  be the early radiation modes;  $B$ , the late radiation modes; and  $C$ , the modes inside the horizon. AMPS argue that the strong subadditivity relation of the entropy [12],

$$S_{AB} + S_{BC} \geq S_B + S_{ABC}, \quad (2)$$

is violated unless a free-falling observer burns out by the firewall. They say that the absence of tragic drama implies  $S_{BC} = 0$  and so  $S_{ABC} = S_A$ . Because  $S_B > 0$  is guaranteed by the thermality of  $B$ ,  $S_{AB} > S_A$  is derived from Eq. (2). In fact, the black hole loses its entropy and  $S_{AB} < S_A$  holds. Therefore, they conclude that the no-firewall assumption is wrong. Besides, since  $A$  and  $B$  are almost maximally entangled with each other in a typical state by the same philosophy of Page curve [13],  $B$  is purified by a subsystem of  $A$ , which is denoted by  $\bar{B}_A$  ( $\subset A$ ) [9]. Thus it seems that  $B$  and  $\bar{B}_A$  are in a pure entangled state. This implies  $S_{\bar{B}_A B} = 0$  and  $S_{\bar{B}_A BC} = S_C$ . Therefore the typical-state argument and strong additivity among  $\bar{B}_A$ ,  $B$  and  $C$  derive  $I_{BC} = S_B + S_C - S_{BC} \leq 0$ . Because  $I_{BC}$  is mutual information of  $B$  and  $C$ ,  $I_{BC}$  is non-negative. Thus we obtain  $I_{BC} = 0$ . However, the no-drama condition implies  $I_{BC} \gg 1$  and seems to contradict the typical-state result.

Only a very short while after this paradox was raised last year, there have already been numerous efforts [14] to resolve it by direct attacks to the gravitational system. However, the answer remains elusive because we are yet to arrive at a quantum gravity theory. In this paper, a different strategy is taken against the paradox. We analyze not the gravitational system but instead a moving mirror model of a free massless scalar field as one of the best quantum systems to test the validity of AMPS's reasoning about the firewall. It is well known that moving mirrors reproduce emission of Hawking radiation [15, 16]. The dynamics of the system is very simple and completely unitary. In accordance with the Reeh–Schlieder theorem [17, 19],  $L$  is fully entangled with  $E$ . Based on the theorem, it can be argued that any state of  $L$  can be arbitrarily reproduced closely by operating a polynomial of local  $E$  operators on the final state of scattering with the mirror. Owing to the finiteness of the Hilbert space dimensions, this means that we can construct a local measurement operator of  $E$  [12] that yields an arbitrary post-measurement state of  $L$ .

Though the AMPS assumptions seem satisfied on first glance, it is noticed that no firewall appears with deadly huge average energy flux in the moving mirror model, because the average values of energy-momentum tensor are finite everywhere. As argued in Section 3, the reason of no firewalls is that the continuum limit using regularization with Poincaré and conformal invariances modifies the UV entanglement structure of typical states to generate a low-energy effective field theory. Therefore, the maximal entanglement condition assumed by AMPS is not sustained in this limit. It seems very plausible that this modification of the entanglement structure in the continuum limit may

also occur for the entanglement of  $E$  and  $L$  of the gravitational system to avoid the original AMPS paradox. In this paper, it is also argued that the strong subadditivity argument of AMPS has a serious flaw from a viewpoint of locality.

Our results suggest that Page curve argument is not able to be applied precisely to black hole evaporation. Originally, the argument is based on appearance of almost maximum entanglement in typical-state models with huge degeneracy and small interaction [6, 7, 8]. The models are proposed just for exploring foundation of statistical mechanics in macroscopic systems which consist of a huge number of the same-energy components interacting with each other via very small coupling constants. However, many interacting systems like ordinary (uniformly distributed) spin networks with finite dimensions do not satisfy this condition. The number density of states usually increases very fast as energy increases. Thus the energy of "typical states" in the Hilbert space is of almost the same order of the maximum energy of the system. If we ignore the low-energy-state contribution, the standard analyses [6, 7, 8] mean that two large complementary subsystems have almost maximum entanglement in a typical state with typical energy, though the energy is very high. Therefore, entanglement entropy between the subsystems is proportional to volume of the smaller subsystem if the subsystems are uniformly distributed. This is actually a volume law of entanglement entropy, not an area law. As opposed to the typical states with typical high energy, it is well known that low-energy states near the ground state obey area laws of entanglement entropy [28][29]. Note that, even in quantum field theory, entanglement entropy of the vacuum state and low-energy states also obeys the (approximated) area law, not the volume law [28]. This may imply that the almost maximum entanglement cannot be attained in ordinary low-energy states of quantum fields. Hence, in the context of firewall arguments, it is naturally expected that the description of low-energy field theory does not allow the almost maximum entanglement between two complementary subsystems. Thus the Page curve picture may be inappropriate in cases with initial low-energy states, which are prepared by some physical selection rule like [20].

Although we do not have any firewall with nonzero expectation values of firewall particle number, an extended firewall paradox inevitably arises in this model when a general measurement of  $E$  is performed, as shown in Section 4. (The similar paradox appears in a more simple case of Rindler horizon.)

However, we prove that the measurement does not make the firewall emerge, provided the energy cost of the  $E$  measurement, which outputs information about  $L$ , is much smaller than the ultraviolet cutoff scale. In the black hole system, a similar paradox may arise, but too much measurement energy induces a large back reaction to spacetime and may cause formation of a new black hole in the measurement region and enclose the measurement device within the event horizon before it outputs results. Thus a conjecture, firewall information censorship (FIC), can be proposed whereby information about encounters with firewalls is never exposed to our low-energy world. This is a conjecture similar to that of extreme cosmic censorship (ECC) [20], which selects out regular initial states to avoid firewalls. However, it should be emphasized that ECC does not prohibit the firewall emergence when we perform general  $E$  measurements. In this paper, it is also argued that vacuum fluctuation is fully entangled with the late radiation modes  $B$  and the interior modes  $C$ . This implies that  $S_{BC} > 0$  without generating the firewall, and it avoids the violation of strong subadditivity in Eq. (2).

The paper is organized as follows. In Section 2, the firewall paradox is posed along the line of reasoning of [1] in a moving mirror model. The resolution of the paradox is described in Section 3. The entropic firewall paradox regarding strong subadditivity is resolved from the viewpoint of strictly localized states in quantum field theory. In Section 4, we pose another firewall paradox based on quantum measurement. The paradox is resolved from a viewpoint of energy cost of measurements. This results suggests a cosmic censorship conjecture in quantum information theory. In Section 5, we summarize our results. We adopt the natural units  $c = \hbar = 1$  in this paper.

## 2 AMPS Paradox for a Moving Mirror

It is known that by omitting the curvature outside event horizons, moving mirror models can mimic the gravitational collapse of a spherical massless shell in Einstein gravity [23, 24]. The mirror arises at the origin of the spherical coordinates ( $r = 0$ ). The mirror motion is caused by the time evolution of the global spacetime structure. Fig. 1 depicts a time-radius

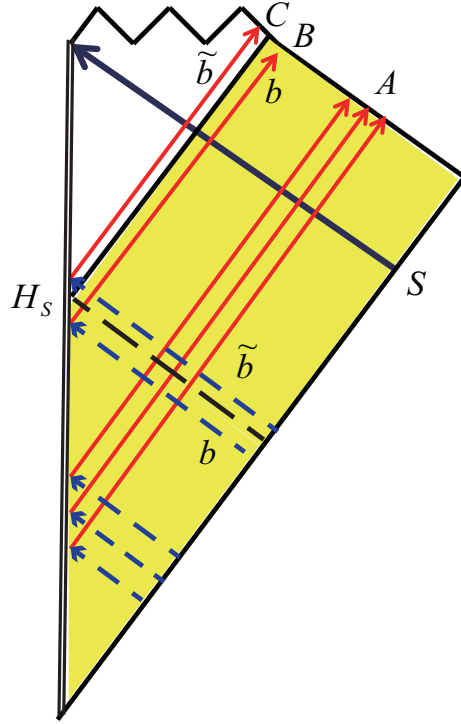

Figure 1: (color online). Penrose diagram of the gravitational collapse of a massless spherical shell.

Penrose diagram of the collapse. The arrow denoted by  $S$  indicates the massless shell motion, which forms an event horizon  $H_S$ . Entangled Rindler modes at both sides of  $H_S$  are denoted by  $b$  and  $\tilde{b}$  in Fig. 1 and are fully entangled. The shaded region in Fig. 1 can be mapped into the moving-mirror flat spacetime, which is depicted as a truncated Penrose diagram in Fig. 2.  $M$  in Fig. 2 denotes the mirror trajectory, corresponding to  $r = 0$  of the gravitational collapse. The horizon  $H_S$  is mapped into  $x^- = \infty$  in this diagram. Clearly, in the moving mirror model,  $\tilde{b}$  of  $C$  corresponds to a late-time infalling mode.

Let us consider a (1+1)-dimensional flat spacetime with a moving mirror, the trajectory of which is given by

$$x^+ = f(x^-),$$

where  $x^\pm$  are light-cone coordinates defined by  $x^\pm = t \pm x$  [15, 16]. On the

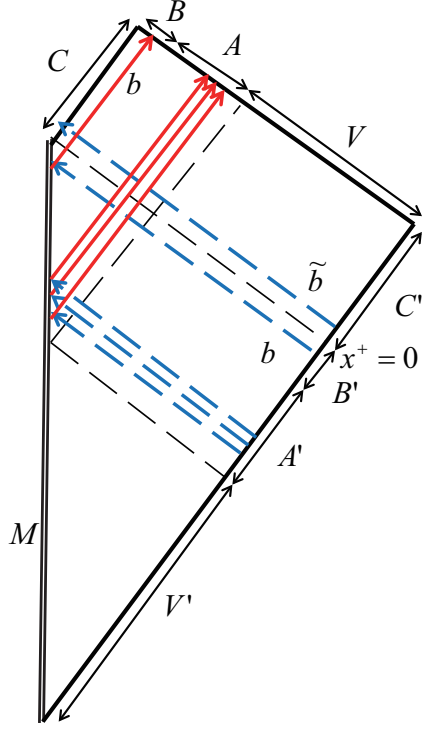

Figure 2: (color online). Schematic diagram of a moving mirror with the trajectory in Eq. (4).

right-hand-side region, a massless scalar quantum field  $\hat{\varphi}$  obeys the equation of motion as  $(\partial_t^2 - \partial_x^2)\hat{\varphi} = 0$ , and it vanishes at the location of the mirror:

$$\hat{\varphi}|_{x^+=f(x^-)} = 0.$$

The solution is given by

$$\hat{\varphi} = \hat{\varphi}_{in}(x^+) - \hat{\varphi}_{in}(f(x^-)), \quad (3)$$

where  $\hat{\varphi}_{in}(x^+)$  is the incoming field operator.  $\hat{\varphi}_{in}(x^+)$  can be expanded as

$$\hat{\varphi}_{in}(x^+) = \int_0^\infty \left( \hat{a}_\omega e^{-i\omega x^+} + \hat{a}_\omega^\dagger e^{i\omega x^+} \right) \frac{d\omega}{\sqrt{4\pi\omega}}$$

with creation and annihilation operators  $\hat{a}_\omega^\dagger$  and  $\hat{a}_\omega$  satisfying  $[\hat{a}_\omega, \hat{a}_{\omega'}^\dagger] = \delta(\omega - \omega')$ . The in-vacuum state  $|0_{in}\rangle$  is defined by  $\hat{a}_\omega|0_{in}\rangle = 0$ . The outgoing



field operator  $\hat{\varphi}_{out}(x^-)$  is introduced by

$$\hat{\varphi}_{out}(x^-) = \hat{\varphi}_{in}(f(x^-)).$$

In terms of plane-wave modes,  $\hat{\varphi}_{out}(x^-)$  can be expanded as

$$\hat{\varphi}_{out}(x^-) = \int_0^\infty \left( \hat{b}_\omega e^{-i\omega x^-} + \hat{b}_\omega^\dagger e^{i\omega x^-} \right) \frac{d\omega}{\sqrt{4\pi\omega}},$$

where  $\hat{b}_\omega^\dagger$  and  $\hat{b}_\omega$  are creation and annihilation operators obeying  $[\hat{b}_\omega, \hat{b}_{\omega'}^\dagger] = \delta(\omega - \omega')$ . Unless the mirror is in inertial motion,  $\hat{b}_\omega$  is described as a mixture of  $\hat{a}_\omega$  and  $\hat{a}_\omega^\dagger$  such that

$$\hat{b}_\omega = \int_0^\infty d\omega' \left( B_\omega(\omega') \hat{a}_{\omega'} + C_\omega(\omega') \hat{a}_{\omega'}^\dagger \right).$$

The appearance of the nonvanishing coefficient  $C_\omega(\omega')$  means particle creation induced by the mirror motion. Let us first consider the mirror trajectory

$$f(x^-) = -\frac{1}{\kappa} \ln \left( 1 + e^{-\kappa x^-} \right), \quad (4)$$

where  $\kappa$  is a positive parameter. The mirror stops in the far past ( $x^- \sim -\infty$ ) and approaches a light geodesic  $x^+ = 0$  in the future ( $x^- \sim \infty$ ). In Fig. 3, the trajectory is drawn in spacetime. The left-going lines represent incoming light rays and the right-going lines represent the reflective light rays. By solving the mirror trajectory as  $x^- = g(x^+)$ , the outgoing mode function is described as

$$v_\omega(x^+) = e^{-i\omega g(x^+)} = \left( e^{-\kappa x^+} - 1 \right)^{i\frac{\omega}{\kappa}},$$

where  $-\infty < x^+ < 0$ . In a way similar to that used for computing  $C_\omega(\omega')$  in the original work by Hawking [21], approximating  $v_\omega(x^+)$  by its dominant contribution  $(-\kappa x^+)^{i\frac{\omega}{\kappa}}$  around  $x^+ \sim 0$  yields

$$\langle 0_{in} | \hat{b}_\omega^\dagger \hat{b}_\omega | 0_{in} \rangle = \int_0^\infty |C_\omega(\omega')|^2 d\omega' \propto \frac{1}{\exp(\frac{2\pi}{\kappa}\omega) - 1}.$$

This implies that the mirror generates thermal radiation with temperature  $T = \kappa/(2\pi)$ . This interpretation can be cross-checked by estimating the

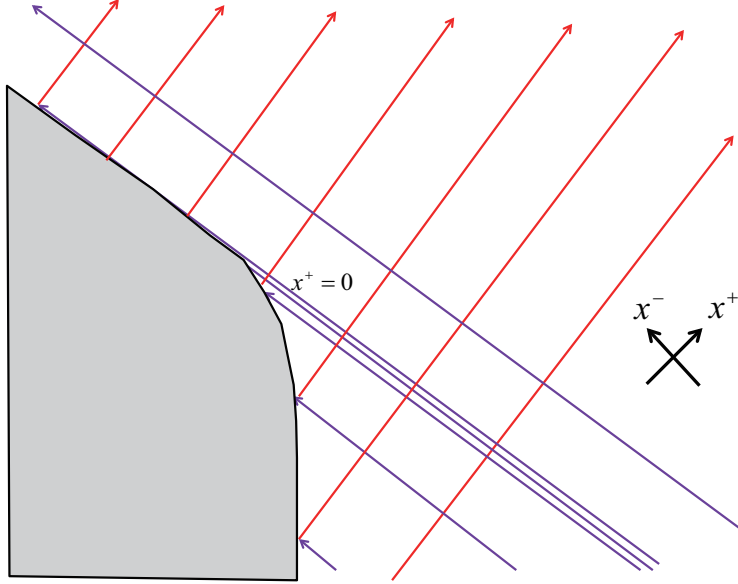

Figure 3: (color online). Penrose diagram of a moving mirror with the trajectory in Eq. (4).

energy flux. In general, a mirror with a trajectory  $x^+ = f(x^-)$  emits energy flux given by

$$\langle 0_{in} | \hat{T}_{--}(x^-) | 0_{in} \rangle = -\frac{1}{24\pi} \left[ \frac{\partial_{x^-}^3 f(x^-)}{\partial_{x^-} f(x^-)} - \frac{3}{2} \left( \frac{\partial_{x^-}^2 f(x^-)}{\partial_{x^-} f(x^-)} \right)^2 \right]. \quad (5)$$

For the trajectory in Eq. (4), the energy flux at  $x^- \gg 1/\kappa$  coincides with the thermal flux with temperature  $T$ :

$$\langle 0_{in} | \hat{T}_{--}(x^- \gg 1/\kappa) | 0_{in} \rangle = \frac{\pi}{12} T^2.$$

At the past null infinity of Fig. 2, the field  $\hat{\varphi}$  is in  $|0_{in}\rangle$ . The system at the past null infinity is divided into three subsystems:  $V'$ ,  $C'$ , and a composite system  $A'B'$ . The systems  $V'$ ,  $A'$ , and  $B'$  evolve into  $V$ ,  $A$ , and  $B$  of the future null infinity with  $x^+ \sim \infty$ .  $A$  corresponds to the early radiation modes and  $B$  to the late radiation modes in the gravitational collapse in Fig. 1. Subsystem  $V$  denotes the out-vacuum fluctuation with no radiation energy. The composite system  $AB$  denotes the radiation emitted from the

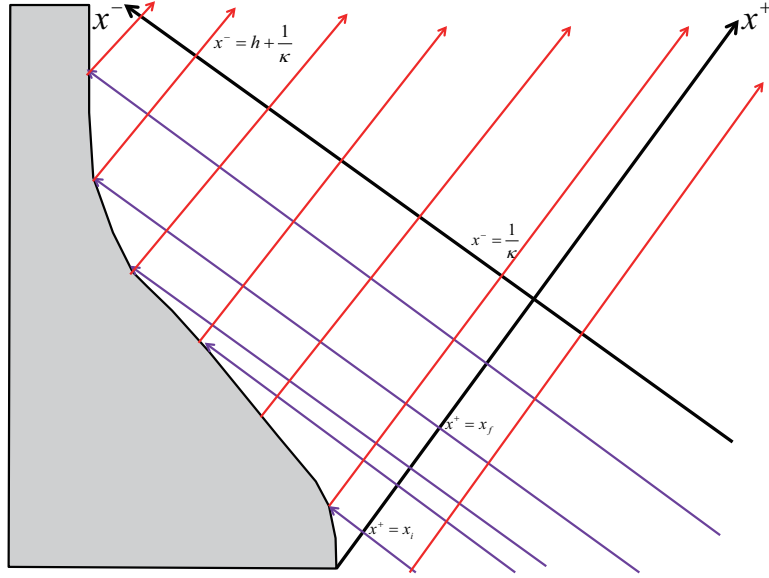

Figure 4: (color online). Schematic diagram of a moving mirror with the trajectory in Eq. (6).

mirror. The red lines in Fig. 2 represent the rays of radiation. The broken lines represent the infalling modes corresponding to the rays. Subsystem  $C'$  evolves into  $C$  of a separate future null infinity with  $x^- \sim \infty$ . Subsystem  $C$  corresponds to the mode absorbed by a black hole, that is, the interior mode, as mentioned above.

Now let us formulate a firewall paradox in this model. Consider a mirror trajectory given by

$$f_h(x^-) = -\frac{1}{\kappa} \ln \left( \frac{1 + e^{-\kappa x^-}}{1 + e^{\kappa(x^- - h)}} \right), \quad (6)$$

where  $h$  is a real parameter satisfying  $h \gg 1/\kappa$ . When  $h \rightarrow \infty$ , the mirror trajectory approaches the trajectory in Eq. (4). However, the future structure of spacetime is different. The trajectory is depicted in Fig. 4. At  $x^- \gg h + 1/\kappa$ , the mirror comes to rest and eventually stops emitting radiation. The Penrose diagram is shown in Fig. 5. As opposed to the situation in Fig. 2, we have a single future null infinity. The region of the almost thermal radiation subsystem  $AB$  is now truncated to  $(1/\kappa, h + 1/\kappa)$ . As shown

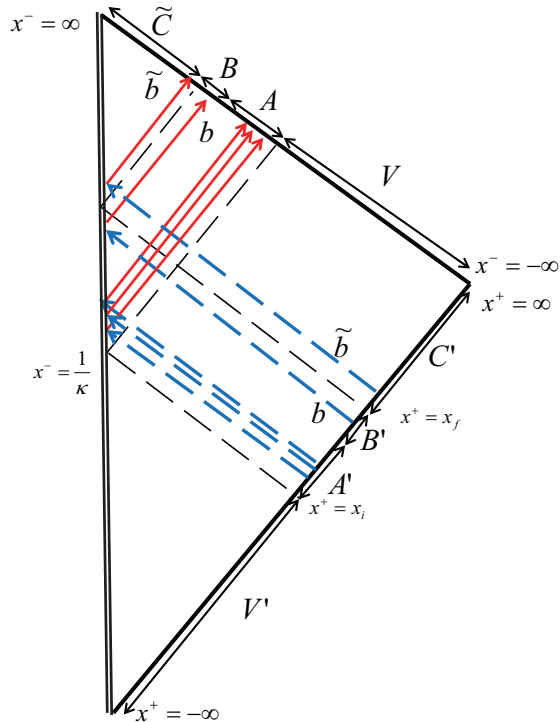

Figure 5: (color online). Penrose diagram of a moving mirror with the trajectory in Eq. (6).

in Fig. 5, subsystem  $\tilde{C}$  mimics the final informative radiation in complete evaporation of a black hole.  $\tilde{C}$  is the entangled partner of  $ABV$  and purifies the total system in this model. Because it is still unclear whether the moving mirror model has a holographic description like AdS, we do not know whether  $\tilde{C}$  really corresponds to a subsystem of a boundary CFT. However, even if this is the case, it should be stressed that  $\tilde{C}$  in our model does not correspond to all the interior modes inside the black hole including the initial collapsing matter.  $\tilde{C}$  merely carries information of the free field interior modes  $\hat{\varphi}$  to guarantee that the final state of the  $\hat{\varphi}$  field is exactly pure. Hence, our argument does not conclude that  $A = R_B$  or  $\tilde{B} \subset E$ , as discussed in literature [22].

If we have a mode excitation of  $AB$  at the future null infinity, depicted as the red curve in Fig. 6, the mode is strongly blueshifted before scattering

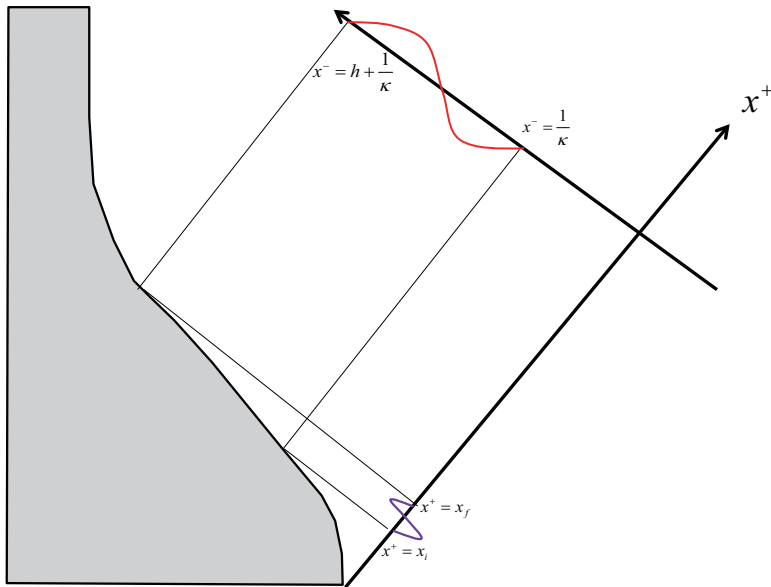

Figure 6: (color online). Schematic diagram representing the blueshift (redshift) by the moving mirror.

with the mirror and returns in time to a region defined by  $(x_i, x_f)$  at the past null infinity, as shown by the short-interval wave curve in Fig. 6. The severe blueshift occurs because the width of the past subsystem  $A'B'$  is much smaller than that of the future subsystem  $AB$ :

$$x_f - x_i \ll h.$$

This classical blueshift property plays an essential role in the paradox. Note that any entanglement is conserved in time because the modes are simply stretched during the reflection by the mirror. Thus, we can always analyze entanglement at a future time by using the past entanglement. Based on this fact, it can be argued that a late-mode subsystem  $L$ , which is a composite system of  $B$  and  $\tilde{C}$ , is fully entangled with an early-mode subsystem  $E$  composed of  $V$  and  $A$ . As opposed to AMPS, it should be stressed that  $L$  includes the future zero-point fluctuation after the mirror stops and that  $E$  includes the past zero-point fluctuation before the mirror moves. In Fig. 7, a subsystem  $L'$  ( $E'$ ) at the past null infinity time evolves to  $L$  ( $E$ ). Therefore, entanglement between  $L$  and  $E$  is equal to that between  $L'$  and  $E'$  in  $|0_{in}\rangle$ .

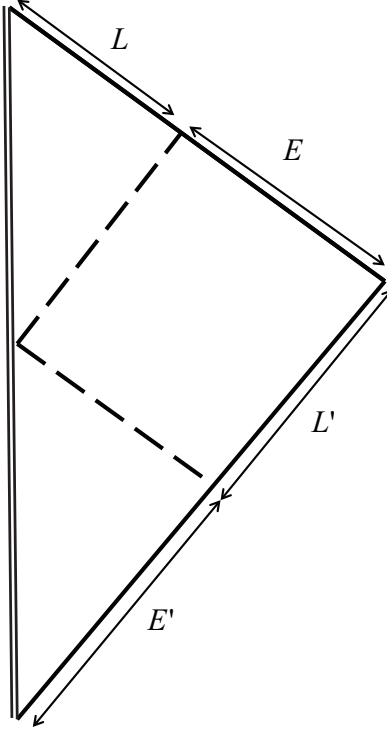

Figure 7: Penrose diagram representing the division setup of the system at asymptotic null infinities. The broken line denotes the boundary of  $E$  and  $L$ .

Using Unruh modes [25], it turns out that  $L'$  and  $E'$  are fully entangled such that

$$|0_{in}\rangle = \prod_{\omega} \left( \sum_n \frac{e^{-n\frac{\pi\omega}{a}}}{\sqrt{Z(\frac{\omega}{a})}} |n(\omega)\rangle_{L'} |n(\omega)\rangle_{E'} \right), \quad (7)$$

where  $a$  is a free positive parameter that indicates the acceleration of the Unruh modes,  $Z(\frac{\omega}{a}) = \sum_n e^{-n\frac{2\pi\omega}{a}}$ , and  $|n(\omega)\rangle_{L'}(|n(\omega)\rangle_{E'})$  is the number eigenstate of  $n$  Rindler particles with frequency  $\omega$  for  $L'$  ( $E'$ ). If the modes are regularized in terms of the Unruh modes with frequency cutoff  $K$  and particle number cutoff  $N$ , it is directly verified that  $|0_{in}\rangle$  is indeed an almost

maximally entangled state between  $E'$  and  $L'$  when we consider a large  $a$ :

$$\begin{aligned}
|0_{in}\rangle &= \lim_{a \rightarrow \infty} \prod_{k=1}^K \left( \sum_{n=0}^N \frac{e^{-n \frac{\pi \omega_k}{a}}}{\sqrt{Z(\frac{\omega}{a})}} |n(\omega_k)\rangle_{L'} |n(\omega_k)\rangle_{E'} \right) \\
&= \prod_{k=1}^K \left( \frac{1}{\sqrt{N}} \sum_{n=0}^N |n(\omega_k)\rangle_{L'} |n(\omega_k)\rangle_{E'} \right). \tag{8}
\end{aligned}$$

Therefore, in this regularization,  $|0_{in}\rangle$  can be regarded as a typically entangled state in the context of References [6, 7, 8]. Of course, the same is true for  $E$  and  $L$  at the future null infinity. Thus this model satisfies the entanglement condition of Reference [1]. However, it should be emphasized here that no firewalls with divergent expectation values of the energy-momentum tensor appear in the model. In fact, the expectation value of the energy-momentum tensor is finite everywhere. Why does the firewall disappear? The reasons are explained in the next section.

### 3 Resolution of AMPS Paradox

The regularization, which is adopted in the previous section, satisfies neither special relativistic invariance nor conformal invariance. In particular, it does not satisfy transitional invariance under  $x^+ \rightarrow x^+ + c$ . In fact, the state of the border region between  $E'$  and  $L'$  ( $E$  and  $L$ ) becomes singular when we consider  $K \rightarrow \infty$  and  $N \rightarrow \infty$ . This implies that the regularization does not allow a continuum limit to a low-energy field theory. If we adopt any other regularization that maintains the conformal invariance, the superficial  $a$  dependence in Eq. (7) is eliminated. More precisely, the Unruh representation of  $|0_{in}\rangle$  is given by:

$$|0_{in}\rangle \propto \exp \left( \int_0^\infty e^{-\frac{\pi \omega}{a}} b_\omega^\dagger \tilde{b}_\omega^\dagger d\omega \right) |0_{Rindler}\rangle,$$

where  $b_\omega^\dagger$  and  $\tilde{b}_\omega^\dagger$  are creation operators of the Rindler particles satisfying  $[b_{\omega_1}, b_{\omega_2}^\dagger] = [\tilde{b}_{\omega_1}, \tilde{b}_{\omega_2}^\dagger] = \delta(\omega_1 - \omega_2)$ , and  $|0_{Rindler}\rangle$  is the Rindler vacuum state defined by  $b_\omega |0_{Rindler}\rangle = \tilde{b}_\omega |0_{Rindler}\rangle = 0$ . By changing variables as  $\omega' = \frac{\omega}{a}$ ,  $b'_{\omega'} = \sqrt{a} b_\omega$ , and  $\tilde{b}'_{\omega'} = \sqrt{a} \tilde{b}_\omega$ , it is easily checked that the  $a$  dependence

vanishes in  $|0_{in}\rangle$  as

$$|0_{in}\rangle \propto \exp\left(\int_0^\infty e^{-\pi\omega'} b_{\omega'}^\dagger \tilde{b}_{\omega'}^\dagger d\omega'\right) |0_{Rindler}\rangle, \quad (9)$$

where  $[b_{\omega'_1}^\dagger, b_{\omega'_2}^\dagger] = [\tilde{b}_{\omega'_1}^\dagger, \tilde{b}_{\omega'_2}^\dagger] = \delta(\omega'_1 - \omega'_2)$ . Thus the continuum limit using regularization with the invariances modifies the UV entanglement structure of typical states to generate a low-energy effective field theory. Therefore, the maximal entanglement condition assumed by AMPS is not sustained in this limit. This is the most fundamental reason why AMPS's firewalls do not appear in the moving mirror model [26]. It seems very plausible that this modification of the entanglement structure in the continuum limit may also occur for the entanglement of  $E$  and  $L$  of the gravitational system to avoid the original AMPS paradox.

The reason for no firewalls can be also understood from a viewpoint of entanglement. In the AMPS argument, it is assumed that quantum state of the composite system is a typical pure state at a given time, in which a small subsystem is almost maximally entangled with its complement subsystem. This implies that entanglement entropy between them is proportional to volume of the small subsystem. The entanglement history of black hole evaporation are precisely imprinted into a sequence from early radiation to late radiation in future null infinity region. Thus very early radiation should be almost maximally entangled with other radiation. However, the radiation is described by a low-energy field theory. Note that, in such a low-energy theory, the entanglement entropy between a subsystem and its complement is proportional to the boundary area, not the volume of the subsystem [29]. Therefore, as opposed to a naive expectation, the quantum state is not an almost maximally entangled state. That is, the state is not a typical one. Actually it is selected so as to satisfy natural conditions of the symmetries of field theory and small excitation energy in the continuum limit. This fact clarifies that the Page curve argument [13], which is based on the typical state assumption, is also incorrect as long as the description of low-energy field theory is reproduced in null future infinity.

Next, we explain how the entropic paradox of firewalls related to Eq. (2) is resolved in the moving mirror model. First, the entanglement entropy between the region  $[x_1^-, x_2^-]$  at the future null infinity and its complement



region is computed as:

$$S(x_1^-, x_2^-) = \frac{1}{12} \ln \left( \frac{(f(x_2^-) - f(x_1^-))^2}{\partial f(x_2^-) \partial f(x_1^-) \epsilon_1^- \epsilon_2^-} \right), \quad (10)$$

where  $\epsilon_1^-$  ( $\epsilon_2^-$ ) is a width cutoff of the boundary at  $x^- = x_1^-$  ( $x^- = x_2^-$ ) [24]. The outline of derivation of Eq. (10) is given in Appendix 1. Now, let us consider  $V$  as  $E$  and a system composed of  $AB$  and  $\tilde{C}$  as  $L$ . It should be stressed here that there is no positive-energy radiation in  $E$ . Thus, in this case,  $L$  is entangled with this fluctuation with zero energy. The idea that quantum fluctuations with zero energy is entangled with Hawking radiation was stressed first by Wilczek [23] in the context of the information-loss problem.

Note that the late-part radiation  $B$  in the original scenario of [1] corresponds to  $B$  in Fig. 5. Mode  $C$  inside the horizon of [1] corresponds to  $C$  in Fig. 2, and so to  $\tilde{C}$  in Fig. 5. In this model, the composite system of  $B$  and  $C$  is fully entangled with a system composed of  $A$ , and the vacuum fluctuation  $V$  with zero energy. By using Eq. (10), it turns out that almost all of the entanglement of the  $BC$  composite system is shared by  $V$ , and the contribution of  $A$  is negligibly small. This distribution of entanglement can be attributed to the region width of  $A'B'$  being much smaller than that of  $V'$  owing to the blueshift factor of  $A'B'$  at the past null infinity. Thus, the existence of this entanglement shared by  $V$  results in  $S_{BC} > 0$ , and so the contradiction to the strong subadditivity in Eq. (2) is avoided. This observation strongly suggests that entanglement between Hawking radiation and vacuum fluctuation with zero energy also plays a crucial role in avoiding the original entropic paradox of [1] in quantum gravity.

What is wrong with the entropic argument of [1] and [11] in this model? The authors of [1] and [11] assume that the outside particle  $B$  and the inside particle  $C$  are in a purely entangled state as

$$\sum_n e^{-n \frac{\pi\omega}{a}} |n(\omega)\rangle_B |n(\omega)\rangle_C.$$

This is a correct statement. However, mode  $B$  has a long tail, which does not vanish in the region of early-part radiation mode  $A$ . Thus, the separation between systems  $A$  and  $B$  is not sufficient. This flaw does not change even if we consider wave-packet modes by superposing one-particle states [21, 35, 27]. The wave packets indeed become localized to some extent; however, they

still have a long tail that merely decays through a power law. Besides, if a localized wave packet basis is adopted,  $|0_{in}\rangle$  cannot be exactly written in the form of Schmidt decomposition like Unruh representation. The Schmidt decomposition of  $|0_{in}\rangle$  is attained only when the plane-wave mode functions are adopted for  $ABV$ . Thus, the locality of  $A$  and  $B$  is not established completely. This implies that  $B$  includes a part of  $A$ . In such a situation, the strong subadditivity relation need not hold true. In general, the strict localization of quantum states cannot be attained by superposing one-particle states in relativistic quantum field theory [36]. If we adopt strictly localized states as  $A$ ,  $B$ , and  $C$ , the purity of the final state can be recovered only when we consider the whole quantum system including the local vacuum part  $V$ , as discussed above.

Besides, as mentioned above,  $A$  and  $B$  cannot share the (almost) maximum entanglement as opposed to a native expectation from the discrete-model analysis. In order to reproduce low-energy field theory with translational and scale invariances, the high-energy entanglement structure of Eq. (8) should be modified as that of Eq. (9). Thus  $S_{\bar{B}AB} = 0$  and  $S_{\bar{B}ABC} = S_C$  cannot be derived. Thus  $I_{BC} = 0$  is not correct. Thus the entanglement structure in Eq. (9) does not contradict the no-drama condition with  $I_{BC} \gg 0$ . In conclusion, no informational paradox arises in the moving mirror model.

The extension of our result for two-dimensional moving mirrors to four-dimensional gravitational collapse is not straightforward. In this analysis, we just consider its S mode contribution neglecting local curvature effect. In order to treat the four dimensional case, we take account of higher modes and potential terms induced by local curvature outside the horizon. It is possible in principle that entanglement entropy contribution of higher modes is evaluated using the two-dimensional models, but the formula in Eq. (10) cannot be applied because it is derived by use of conformal symmetry. Besides, the height of the potential becomes larger in the final stage of black hole evaporation and may drastically change the fate of the black hole.

Here, a comment is given about the renormalized entropy:

$$S_{ren}(x_1^-, x_2^-) = \frac{1}{12} \ln \left( \frac{(f_h(x_2^-) - f_h(x_1^-))^2}{\partial f_h(x_2^-) \partial f_h(x_1^-) (x_2^- - x_1^-)^2} \right), \quad (11)$$

which is provided in [24]. Since  $S_{ren}(x_1^-, x_2^-)$  is defined as an excess entanglement with reference to the vacuum entanglement [27], one might expect that

$S_{ren}(x_1^-, x_2^-)$  describes the entanglement between low-energy excitations of the field by terminating the vacuum contribution. However, this is not correct. In fact,  $S_{ren}(x_1^-, x_2^-)$  still explicitly depends on the size of the local vacuum region. In fact, even when the point  $x^- = x_1^-$  belongs to the local vacuum region  $V$  with  $f(x_1^-) = x_1^-$  and  $\partial f(x_1^-) = 1$ , the renormalized entropy still depends on  $x_1^-$  as

$$S_{ren}(x_1^-, x_2^-) = \frac{1}{12} \ln \left( \frac{(f_h(x_2^-) - x_1^-)^2}{\partial f_h(x_2^-) (x_2^- - x_1^-)^2} \right).$$

Thus, it is concluded that  $S_{ren}(x_1^-, x_2^-)$  still includes the vacuum entanglement contribution. Note that the enormous amount of vacuum state entanglement, which is guaranteed by the Reeh–Schlieder theorem, includes a high-energy contribution as well as a low-energy contribution, because an arbitrary state of  $L$  can be generated independent of its excitation energy using a local operator acting on  $E$ . No natural threshold separating the high-energy contribution from the low-energy contribution of  $S$  is known in information theory, because the entanglement itself is a purely informational concept independent of energy. In fact, when self-interactions of the field exist, entanglement mixing between low-energy modes and high-energy modes occurs. Even the finiteness of  $S_{ren}(x_1^-, x_2^-)$  for general quantum states has not yet been proven. It is also unclear that the vanishing value of  $S_{ren}(x_1^-, x_2^-)$  implies the purity of the state of local excitations. Besides, it should be stress that  $S_{ren}(x_1^-, x_2^-)$  does not satisfy the strong additivity as shown in Appendix 2, though it exactly holds for  $S(x_1^-, x_2^-)$ . At present, the meaning of  $S_{ren}(x_1^-, x_2^-)$  remains elusive in the context of quantum information theory. Meanwhile,  $S(x_1^-, x_2^-)$  in Eq. (10) is an appropriate measure of the entanglement to treat high-energy entanglement and low-energy entanglement simultaneously and systematically.

## 4 Emergence and Resolution of Firewall Measurement Paradox

It is assumed that the above firewall prohibition is because we do not actually perform any measurements of  $E$ . In contrast with AMPS’s original

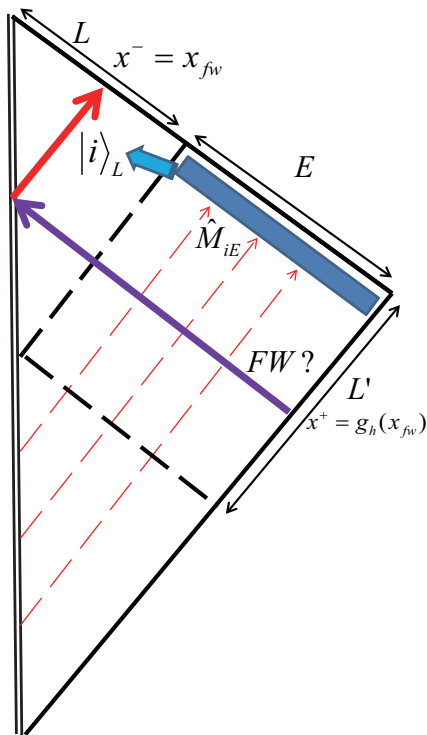

Figure 8: (color online). Penrose diagram representing the measurement of  $E$  to obtain the information of  $L$ . The red and violet arrows denote the firewall.

scenario, if we really perform a measurement of  $E$  to gain the information of  $L$ , another version of the firewall paradox arises in this model. A similar paradox appears in a more simple model of Rindler horizon[18]. The Reeh–Schlieder theorem [17] asserts that the set of states generated from  $|0_{in}\rangle$  through the polynomial algebra of local operators in any bounded spacetime region is dense in the entire Hilbert space of the field. Thus, in principle, any state of  $L'$  can be arbitrarily reproduced closely by operating a polynomial of local  $E'$  operators on  $|0_{in}\rangle$  [19]. This is the same for  $E$  and  $L$ . Assuming finiteness of the Hilbert space dimensions, a measurement operator [12] of  $E$ , the post-measurement state of which includes the firewall, can be constructed. As a result, the observer encounters a firewall as explained below.

First, it is worth recalling that  $|0_{in}\rangle$  is translationally invariant:  $x^+ \rightarrow$

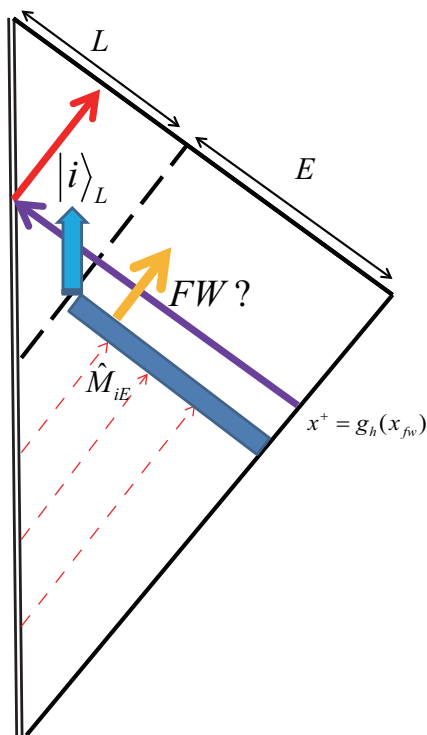

Figure 9: (color online). Penrose diagram representing the firewall paradox in this model. An observer in motion like the yellow arrow will encounter the firewall.

$x^+ + c^+$ . Thus, the entanglement between  $L'$  and  $E'$  is independent of the boundary position. Thus, the entanglement is also independent of where the  $L$ - $E$  boundary is fixed at the future null infinity. Let us consider a general measurement of quantum information theory [12] for the vacuum fluctuation of  $E$  that outputs the result  $i$  [30]. Based on the Reeh-Schlieder theorem, let us consider that, besides the background Hawking radiation, a wave packet with positive energy of the order of the radiation temperature appears at  $x^- = x_{fw}$  in the post-measurement state  $|i\rangle_L$  of  $L$ . As depicted in Fig. 8, the wave packet traveling back in time is severely blueshifted, and it carries a huge amount of energy in  $L'$  at the past null infinity. The deadly energetic flux emerges at  $x^+ = g_h(x_{fw})$ , where  $g_h(x)$  is a solution of  $f_h(g_h(x)) = x$ . Therefore, if the measurement is performed before the firewall forms, as depicted in Fig. 9, an observer attempting to move along the arrow will burn out by

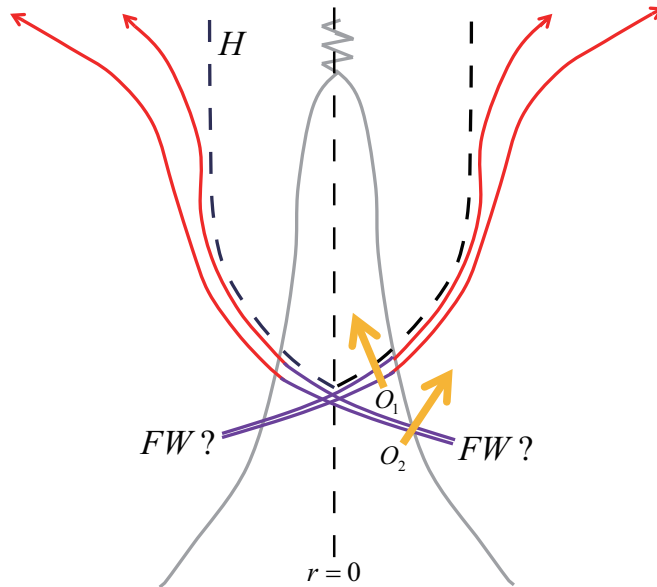

Figure 10: (color online). Schematic diagram of gravitational collapse with firewalls. Observer  $O_1$  encounters an outgoing firewall in the original paradox of AMPS. Observer  $O_2$  encounters an incoming firewall, as well as in the moving mirror model.

the firewall. This is the firewall measurement paradox. If the measurement is not executed, the observer safely passes over  $x^+ = g_h(x_{fw})$ , in contrast to AMPS's original scenario. A similar version of the firewall measurement paradox arises in the original black hole scenario as well. Figure 10 schematically depicts a gravitational collapse in which the outgoing firewall attacks an infalling observer  $O_1$ , as argued in [1]. The second firewall discussed above appears in the incoming modes and will attack a different observer  $O_2$  in Fig. 10. The paradox is similar to the famous Unruh-Wald argument that a particle detector with uniform acceleration generates wave packets in the post-measurement states in a causally disconnected region [31]. However, it should be stressed that general measurements should be analyzed in the firewall arguments, as opposed to the Unruh-Wald one. In the next section, we argue that the firewall does not appear, provided the measurement energy cost is much smaller than the ultraviolet cutoff scale. This leads to the firewall information censorship conjecture.

In the moving mirror models, the time evolution is simple. The plane-wave modes  $\exp(-i\omega x^+)$  of the free field are just stretched into  $\exp(-i\omega f_h(x^-))$  by the mirror trajectory without loss of unitarity and entanglement. Thus, a late-time measurement of  $E$  can be replaced by an early-time measurement of  $E'$ , which yields the same results and post-measurement states. To understand this useful fact more concretely, let us consider a simple example of a general measurement [12] of  $E$  outputting results  $\mu$  with measurement operators

$$\hat{M}_{\mu E} = F_\mu \left( \int \Omega(x^-) \partial_{x^-} \hat{\varphi}_{out}(x^-) dx^- \right),$$

where  $\Omega(x^-)$  is a real window function for  $E$ . The function  $F_\mu(x)$  must satisfy  $\sum_\mu |F_\mu(x)|^2 = 1$  to impose the unitarity condition on the measurement operators [12]. Owing to the relation  $\hat{\varphi}_{out}(x^-) = \hat{\varphi}_{in}(f_h(x^-))$ , this measurement corresponds to a general measurement of  $E'$  with measurement operators defined as

$$\hat{M}_{\mu E'} = F_\mu \left( \int \Omega(g_h(x^+)) \partial_{x^+} \hat{\varphi}_{in}(x^+) dx^+ \right).$$

Notice that  $\Omega(g_h(x^+))$  indeed becomes a window function for  $E'$  at the past null infinity. Taking account of such a correspondence, we consider an arbitrary measurement of  $E'$  outputting  $i$  with measurement operator  $\hat{M}_{iE'}$  obeying the unitary condition

$$\sum_i \hat{M}_{iE'}^\dagger \hat{M}_{iE'} = \hat{I}. \quad (12)$$

The measurement is depicted in Fig. 11. Our task is to check whether the firewall exists in the post-measurement state  $\hat{M}_{iE'}|0_{in}\rangle$ .

When  $x^+$  takes values around  $g_h(x_{fw})$  of  $L'$ , the expectation value of the energy flux for a fixed  $i$  is computed as

$$\langle T_{++}(x^+) \rangle_i \propto \langle 0_{in} | \hat{M}_{iE'}^\dagger \hat{T}_{++}(x^+) \hat{M}_{iE'} | 0_{in} \rangle = \langle 0_{in} | \hat{\Pi}_{iE'} \hat{T}_{++}(x^+) | 0_{in} \rangle, \quad (13)$$

where  $\hat{\Pi}_{iE'} = \hat{M}_{iE'}^\dagger \hat{M}_{iE'}$  is a positive operator valued measure (POVM) of the measurement. Note that  $\langle T_{++}(x^+) \rangle_i$  is just a two-point correlation function of  $\hat{\Pi}'_{iE'}$  and  $\hat{T}_{++}(x^+)$  in the vacuum state. The correlation functions for nonsingular  $\hat{\Pi}_{iE'}$  simply decay via a power law as a function of the distance  $l$  between the boundary of  $E'$  ( $x^+ \sim -1/\kappa$ ) and the would-be firewall position

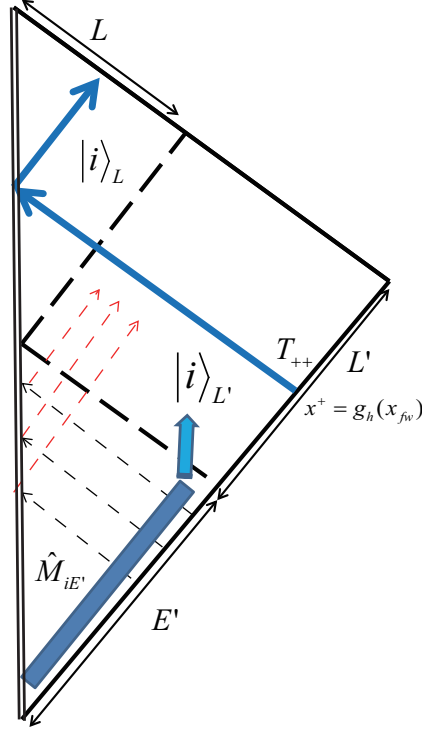

Figure 11: (color online). Penrose diagram representing an early-time measurement of  $E'$ , which provides the same influence as the late-time measurement in Fig. 9.

( $x^+ = g_h(x_{fw})$ ). Therefore, an arbitrary nonsingular measurement is incapable of generating any outstanding peak of  $\langle T_{++}(x^+) \rangle_i$  at  $x^+ = g_h(x_{fw})$ . This implies no firewall for any  $i$ .

For example, in a one-bit measurement of  $E'$  outputting  $i = 0, 1$  with

$$\hat{M}_{0E'} = \cos \left( \int_{-\infty}^{x_{E'}} \lambda_{E'}(x^+) \partial_{x^+} \hat{\varphi}_{in}(x^+) dx^+ \right),$$

$$\hat{M}_{1E'} = \sin \left( \int_{-\infty}^{x_{E'}} \lambda_{E'}(x^+) \partial_{x^+} \hat{\varphi}_{in}(x^+) dx^+ \right),$$

the correlation functions for  $x^+ > x_{E'}$  are computed as

$$\langle 0 | \hat{\Pi}_{iE'} \hat{T}_{++}(x^+) | 0 \rangle = 2 (-1)^{i+1} \left| \int_{-\infty}^{x_{E'}} G(x^+ - x'^+) \lambda_{E'}(x'^+) dx'^+ \right|^2,$$



where  $\lambda_{E'}(x^+)$  is a real function that vanishes at the outside region of  $E'$ ,

$$G(x^+ - x'^+) = \langle 0_{in} | \partial_{x^+} \hat{\varphi}_{in}(x^+) \partial_{x^+} \hat{\varphi}_{in}(x'^+) | 0_{in} \rangle = -\frac{1}{4\pi (x^+ - x'^+ - i0)^2},$$

and it is assumed that  $E'$  lies in the region  $(-\infty, x_{E'})$ . Thus, for both  $i$ , no peak of energy density appears at any  $x^+$  of  $L'$ .

If one wants to create a post-measurement state  $|i\rangle_L$  involving the firewall, quite singular measurement operators should be invoked. Precisely, the total energy after the measurement,

$$\langle \hat{H} \rangle = \sum_i \int_{-\infty}^{\infty} \langle 0_{in} | \hat{M}_{iE'}^\dagger \hat{T}_{++}(x^+) \hat{M}_{iE'} | 0_{in} \rangle dx^+,$$

must be divergent. For instance, let us imagine a post-measurement state  $\hat{M}_{iE'} | 0_{in} \rangle$  for a fixed  $i$  with a sharp energy peak at  $x^+ = g_h(x_{fw})$ , the energy flux of which is approximated by

$$\frac{\langle 0_{in} | \hat{\Pi}_{iE'} \hat{T}_{++}(x^+) | 0_{in} \rangle}{\langle 0_{in} | \hat{\Pi}_{iE'} | 0_{in} \rangle} = E_{fw} \delta(x^+ - g_h(x_{fw})) \quad (14)$$

for  $x^+ > x_{E'}$ . Here,  $E_{fw}$  is the energy of the firewall. From the unitarity condition of the measurement operators in Eq. (12), the total sum of contributions for the measurement results vanishes:

$$\sum_j \langle 0_{in} | \hat{\Pi}_{jE'} \hat{T}_{++}(x^+) | 0_{in} \rangle = \langle 0_{in} | \hat{T}_{++}(x^+) | 0_{in} \rangle = 0.$$

Hence, without loss of generality, we can assume that there is an output  $j$  that satisfies

$$\frac{\langle 0_{in} | \hat{\Pi}_{jE'} \hat{T}_{++}(x^+) | 0_{in} \rangle}{\langle 0_{in} | \hat{\Pi}_{jE'} | 0_{in} \rangle} = -r E_{fw} \delta(x^+ - g_h(x_{fw})),$$

where  $x^+ > x_{E'}$  and  $r = \langle 0_{in} | \hat{\Pi}_{iE'} | 0_{in} \rangle / \langle 0_{in} | \hat{\Pi}_{jE'} | 0_{in} \rangle > 0$ . In fact, this condition holds for a general measurement with one-bit measurement operators such that

$$\hat{M}'_0 = \hat{M}_{iE'}, \quad \hat{M}'_1 = \sqrt{I - \hat{M}_{iE'}^\dagger \hat{M}_{iE'}}.$$

Because  $|0_{in}\rangle$  is a fully entangled state,  $|0_{in}\rangle$  is an eigenstate of neither  $\hat{\Pi}_{iE'}$  nor  $\hat{\Pi}_{jE'}$ , and  $r$  is naturally anticipated as  $O(1)$ . This signifies that we have

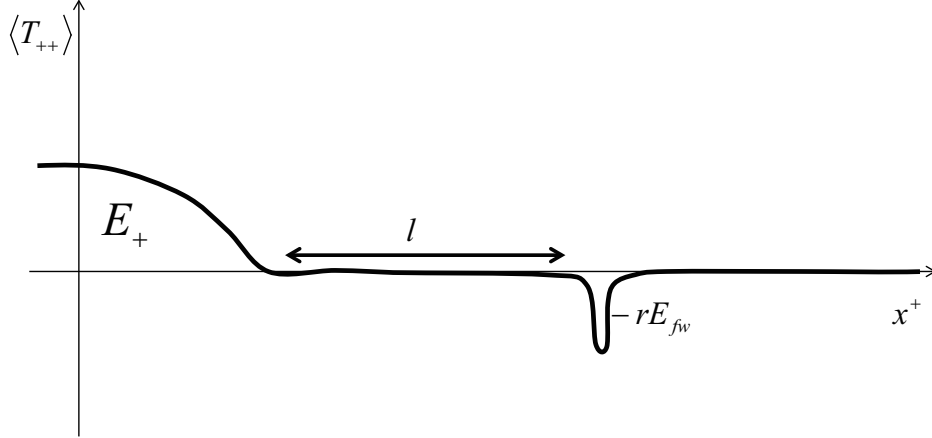

Figure 12: Schematic diagram representing the average energy flux distribution in  $\hat{M}_{jE'}|0_{in}\rangle$ .

a negative-energy shock wave at  $x^+ = g_h(x_{fw})$ . Let  $l$  denote the distance between the shock wave and  $E'$ :

$$l = g_h(x_{fw}) - x_{E'}.$$

To maintain the nonnegativity of the total Hamiltonian of the field in  $\hat{M}_{jE'}|0_{in}\rangle$ , there exists a positive-energy region of  $E'$ . The energy flux distribution is schematically depicted in Fig. 12. A general bound of negative energy for any quantum state in which the total energy is finite [32] enables us to derive the following bound on the firewall energy:

$$E_{fw} < \frac{1}{12\pi r l}. \quad (15)$$

This clearly contradicts the emergence of a firewall with a huge energy flux of the order of the ultraviolet cutoff scale. Thus, actually, a firewall with deadly high energy is not present, as long as the total energy of the post-measurement state is small. The derivation of the bound in Eq. (15) is outlined as follows.

Let us consider a nonnegative continuous function  $\xi(x)$  and define a Hermitian operator as

$$\hat{H}_\xi = \int_{-\infty}^{\infty} \xi(x^+) \hat{T}_{++}(x^+) dx^+.$$

Then, the inequality

$$\mathrm{Tr} \left[ \hat{H}_\xi \hat{\rho} \right] \geq -\frac{1}{12\pi} \int_{-\infty}^{\infty} \left( \partial_x \sqrt{\xi(x)} \right)^2 dx$$

holds for an arbitrary state  $\hat{\rho}$  [33]. Now consider a state  $\hat{\rho}$  satisfying

$$\mathrm{Tr} \left[ \hat{T}_{++}(x^+) \hat{\rho} \right] = -r E_{fw} \delta(x^+ - g_h(x_{fw}))$$

for  $x^+ > x_{E'}$ . Let us impose the values  $\xi(x) = 0$  for  $x \in (-\infty, x_{E'})$  and  $\xi(x) = 1$  for  $x \in (g_h(x_{fw}) - 0, \infty)$  on  $\xi(x)$ . As a result,  $\mathrm{Tr} \left[ \hat{H}_\xi \hat{\rho} \right] = -r E_{fw}$  for an arbitrary  $\xi(x)$  satisfying the above conditions. Thus,

$$r E_{fw} \leq \frac{1}{12\pi} \inf_{\xi(x)} \int_{-\infty}^{\infty} \left( \partial_x \sqrt{\xi(x)} \right)^2 dx$$

must be satisfied. The infimum of the  $\xi(x)$  satisfying the above boundary conditions is then taken. By using a variation method, the infimum is obtained from a function  $\xi_{opt}(x)$  obeying

$$\xi_{opt}(x) = \left( \frac{x - x_{E'}}{l} \right)^2$$

for  $x \in (x_{E'}, g_h(x_{fw}))$ , so the inequality of Eq. (15) can be derived. When  $E_{fw}$  approaches  $\frac{1}{12\pi r l}$ , the positive energy  $E_+$  of  $E'$ , which is injected by the measurement device, is considered to diverge to infinity. In fact, when  $\hat{M}_{jE'}|0_{in}\rangle$  is a squeezed state for example, it can be explicitly proven that  $E_+$  obeys the following inequality:

$$E_+ \geq \frac{r E_{fw}}{1 - 12\pi l r E_{fw}}, \quad (16)$$

where the right-hand side diverges to infinity in the limit of  $E_{fw} \rightarrow \frac{1}{12\pi r l}$ . The proof of Eq. (16) is provided in the appendix 3. Recall that  $E$  is in a local vacuum state with zero energy because the mirror does not move yet at the reflection time of the modes. Hence, when the measurement is performed for  $E$  as in Fig. 9, the measurement energy is the same as that for  $E'$ , and we are able to conclude that no firewall appears provided the measurement energy of  $E$  is much smaller than the cutoff scale.

A similar paradox may be considered in a Rindler horizon model [18]. Imagine an observer who measures the Rindler energy, thereby projecting the state onto a Rindler energy-eigenstate. It is easy to check that in this state, the two point function of a scalar field across the Rindler horizon is ill-behaved. This is the analogue of a "firewall." Note that local measurements generally inject energy on average to the field in  $|0_{in}\rangle$  owing to the passivity of the state [34]. Hence, quantum measurements always require an energy cost. Though the Reeh–Schlieder theorem is mathematically correct, it does not guarantee that the measurement energy required to create  $|i\rangle_L$  is finite even if the measurement operator exists. When we measure Rindler particle number eigenstates  $|n(\omega)\rangle_{E'}$  of Unruh modes in Eq. (7) to create  $|n(\omega)\rangle_{L'}$ , energy of the order of the ultraviolet cutoff scale is injected at the boundary of  $E'$  and  $L'$ . This huge amount of energy diffuses along the future Rindler horizons and will modify spacetime drastically. Beyond our model, singular measurements generally require the preparation of a divergent amount of energy in the measurement region before the measurement is performed, and this energy is expected to provide a large back reaction to spacetime. The effect may cause the formation of a new black hole in the measurement region and enclose the measurement device within the event horizon before it outputs results. Therefore, the estimation of measurement energy is quite important in any thought experiment on firewalls with measurements. This is the main message of this paper. Based on this consideration, we propose a conjecture of firewall information censorship whereby the leakage of the measurement information on encounters with firewalls is prohibited at a profound level.

Before closing this section, we need to comment on measurements of thermal radiation. In the above argument, the measurement is performed in the local vacuum region. However, in the original scenario of [1], the measurement is considered in the early-part radiation region to predict the behavior of the late-part radiation. When we consider the same setup in the moving mirror model, no firewall paradox has a definite meaning because the available measurement region is too small to allow an observer to perform the measurement before encountering firewalls. However, if one wants to infer the existence of firewalls in a past region, it is interesting to treat the early Hawking-like radiation as  $E$ . Let us consider a nonsingular general measurement of  $E$  with measurement operators that output  $\mu$ :

$$\hat{M}_{\mu E} = F_{\mu} \left( \int \Omega_E(x^-) \partial_{x^-} \hat{\varphi}_{out}(x^-) dx^- \right).$$

When the result  $\mu$  of  $E$  is obtained, let us introduce an energy–momentum-tensor gain of  $L$  as

$$\Delta^{(\mu)}T_{--}(x_L^-) = \frac{\langle 0_{in} | \hat{M}_{\mu E}^\dagger \hat{M}_{\mu E} T_{--}(x_L^-) | 0_{in} \rangle}{\langle 0_{in} | \hat{M}_{\mu E}^\dagger \hat{M}_{\mu E} | 0_{in} \rangle} - \langle 0_{in} | T_{--}(x_L^-) | 0_{in} \rangle.$$

Note that the Hawking-like radiation regime is well approximated by the moving mirror trajectory in Eq. (4). By using Eq. (4) and  $x_L^+ = f_h(x_L^-)$ , the gain of  $T_{++}$  at the near horizon ( $x_L^+ \sim 0$ ) is evaluated as

$$\Delta^{(\mu)}T_{++}(x_L^+) = \left( \frac{\partial x_L^-}{\partial x_L^+} \right)^2 \Delta^{(\mu)}T_{--}(x_L^-) \sim \frac{1}{(\kappa x_L^+)^2} \Delta^{(\mu)}T_{--}(x_L^-).$$

If  $\Delta^{(\mu)}T_{--}(x_L^-)$  does not vanish when  $x_L^- \rightarrow \infty$  ( $x_L^+ \rightarrow 0$ ), we confirm the existence of a firewall. However, in the thermal region, the two-point correlation function of  $\partial_{x^-} \hat{\varphi}_{out}(x^-)$  behaves as

$$\begin{aligned} \langle 0_{in} | \partial_{x^-} \hat{\varphi}_{out}(x_L^-) \partial_{x^-} \hat{\varphi}_{out}(x_E^-) | 0_{in} \rangle &= -\frac{\kappa^2}{16\pi \sinh^2\left(\frac{\kappa}{2}(x_L^- - x_E^- - i0)\right)} \\ &\sim O(\exp(-\kappa x_L^-)). \end{aligned}$$

Using this correlation, it is possible to show for nonsingular measurements that  $\Delta^{(\mu)}T_{--}(x_L^-) = O(\exp(-2\kappa x_L^-)) = O((\kappa x_L^+)^2)$  when considering  $x_L^- \sim \infty$ . This implies that  $\Delta^{(\mu)}T_{++}(x_L^+)$  is always finite even if we consider  $x_L^+ \rightarrow 0$ . Hence, no firewall appears in this case either, as long as the measurement is not singular.

## 5 Summary

In a moving mirror model with a free massless scalar field, no AMPS’s firewalls appear even though the final state is pure and fully entangled. The reason is that the continuum limit to a low-energy field theory with conformal invariance modifies the UV entanglement structure of almost maximally entangled states of the discretized systems. The entropic paradox does not

arise in this model. The  $BC$  system in this model is fully entangled with the early vacuum fluctuation  $V$ . This implies that  $S_{BC} > 0$  and allows us to avoid violation of the strong subadditivity in Eq. (2). We have examined an extended firewall paradox with quantum measurement of the early modes  $E$  with the trajectory in Eq. (6). The dynamics of the model is quite simple and exactly unitary. The in-vacuum state  $|0_{in}\rangle$  provides enough entanglement between  $E$  and the late modes  $L$ . It is proven that, as long as nonsingular measurements are adopted, deadly energetic firewalls do not emerge in this case. The crucial point is the energy cost of quantum measurements of  $E$ . Generation of firewalls via entanglement between  $E$  and  $L$  requires quite singular measurements, the energy cost of which is of the order of the ultraviolet cutoff scale, i.e., the Planck scale. Preparation of such a huge measurement energy in a region of  $E$  may provide large back reaction to spacetime before the measurement is executed and may change the problem itself drastically. This consideration leads to the firewall information censorship conjecture, whereby the measurement information leakage of encounters with firewalls is prohibited at a profound level.

### Acknowledgments

We would like to thank Bill Unruh and Joe Polchinski for related discussions. Also we would like to thank one of reviewers in Physical Review D for pointing out the simple model of Rindler horizon using the Reeh–Schlieder theorem. M. H. would like to thank the organizers of the KIAS-YITP joint workshop, “String Theory, Black Holes and Holography” for their hospitality.

## References

- [1] A. Almheiri, D. Marolf, J. Polchinski, J. Sully, J. High Energy Phys. **02**, 062 (2013).cf. S. L. Braunstein, arXiv:0907.1190 published as S. L. Braunstein, S. Pirandola and K. Zyczkowski, ”Better Late than Never: Information Retrieval from Black Holes,” Physical Review Letters 110, 101301 (2013).
- [2] J. M. Maldacena, Adv. Theor. Math. Phys. **2**, 231 (1998).
- [3] S. W. Hawking, Phys. Rev. **D72**, 084013 (2005).
- [4] L. Susskind, L. Thorlacius, J. Uglum, Phys. Rev. **D48**, 3743 (1993).

- [5] W. K. Wootters, W. H. Zurek, *Nature* **299**, 802 (1982).
- [6] E. Lubkin, *J. Math. Phys.* **19**, 1028 (1978).
- [7] S. Lloyd and H. Pagels, *Ann. Phys. (NY)* **188**, 186 (1988).
- [8] D. N. Page, *Phys. Rev. Lett.* **71**, 1291 (1993).
- [9] D. Harlow and P. Hayden, arXiv:1301.4504.
- [10] D. Marolf and J. Polchinski, *Phys. Rev. Lett.* **111**, 171301 (2013).
- [11] S. D. Mathur, *Classical Quantum Gravity* **26**, 224001 (2009).
- [12] M. A. Nielsen and I. L. Chuang, *Quantum Computation and Quantum Information* (Cambridge University Press, Cambridge, England, 2000), p. 90.
- [13] D. N. Page, "Black Hole Information", Proceedings of the 5th Canadian Conference on General Relativity and Relativistic Astrophysics, University of Waterloo, 13–15 May, 1993, edited by R. B. Mann and R. G. McLenaghan (World Scientific, Singapore, 1994), pp. 1-41.
- [14] For a list of the references, see A. Almheiri, D. Marolf, J. Polchinski, D. Stanford, J. Sully, arXiv:1304.6483; D. N. Page, arXiv:1306.0562.
- [15] S. A. Fulling, P. C. W. Davies, *Proc. R. Soc. (London)* **A348**, 393 (1979).
- [16] N. D. Birrell and P. C. W. Davies, *Quantum Fields in Curved Space* (Cambridge University Press, Cambridge, England, 1982).
- [17] H. Reeh, S. Schlieder, *Nuovo Cimento* **22**, 105 (1961).
- [18] We would like to appreciate the reviewer for pointing out the simple model using Rindler horizon.
- [19] A. Peres and D. R. Terno, quant-ph/0212023.
- [20] D. N. Page, arXiv:1306.0562.
- [21] S. W. Hawking, *Commun. Math. Phys.* **43**, 199 (1975).

- [22] R. Bousso, arXiv:1207.5192; Y. Nomura, J. Varela and S. J. Weinberg, arXiv:1210.6348; L. Susskind, arXiv:1301.4505; A. Almheiri, D. Marolf, J. Polchinski, D. Stanford, J. Sully, arXiv:1304.6483.
- [23] F. Wilczek, in *Proceedings of Houston Conference on Black Holes, Membranes, Wormholes and Superstrings*, ed. S. Kalara and D. Nanopoulos (World Scientific, Singapore, 1992), p. 1.
- [24] C. Holzhey, F. Larsen, F. Wilczek, Nucl. Phys. **B424**, 443 (1994).
- [25] W. G. Unruh, Phys. Rev. **D14**, 870 (1976).
- [26] After our submission of this paper, A. Almheiri and J. Sully upload a paper [27], in which they also comment on the reason why firewalls with divergent expectation value of energy momentum tensor do not appear for a trajectory like Eq. (6) in the moving mirror model. They argue that the final informative radiation from the mirror play a role of a remnant, which entangled with early Hawking-like radiation and avoid the emergence of firewalls. However, the "remnant" is merely a radiation of the quantum field, and nothing special. Because the final state remains pure and is entangled enough, their explanation does not help to resolve the AMPS paradox.
- [27] A. Almheiri and J. Sully, arXiv:1307.8149.
- [28] M. Srednicki, Phys. Rev. Lett. **71**, 666 (1993).
- [29] M. M. Wolf, F. Verstraete, M. B. Hastings, and J. I. Cirac, Phys. Rev. Lett. **100**, 070502 (2008).
- [30] M. Hotta, Phys. Rev. D **78**, 045006 (2008); M. Hotta, Phys. Rev. D **81**, 044025 (2010).
- [31] W. G. Unruh and R. M. Wald, Phys. Rev. **D29**, 1047 (1984).
- [32] M. Hotta, J. Matsumoto, G. Yusa, arXiv:1305.3955.
- [33] E. E. Flanagan, Phys. Rev. D **56**, 4922 (1997).
- [34] W. Pusz, S. L. Woronowicz, Commun. Math. Phys. **58**, 273 (1978).
- [35] S. Takagi, Progress of Theoretical Physics Supplement, No.88, (1986).
- [36] J. Knight, Math. Phys. Appl. Math. 2, 459 (1961).



## Appendix 1: Proof Outline of HLW Formula

In this appendix, an outline of derivation of Eq. (10) in [24] is provided by using conformal symmetry. Let us think a massless scalar field  $\hat{\varphi}(x)$  in one dimension. Consider a Rindler observer with acceleration  $\kappa$ . The corresponding Rindler coordinates are given by

$$\begin{aligned} t &= \frac{1}{\kappa} e^{\kappa u} \sinh(\kappa\tau), \\ x &= \frac{1}{\kappa} e^{\kappa u} \cosh(\kappa\tau), \end{aligned}$$

where the trajectory of the observer is given by  $u = 0$ . The field is observed in a thermal state at temperature  $T = \frac{\kappa}{2\pi}$  due to Unruh effect. Because the entropy density in one dimension is computed as  $\varrho = \frac{\pi T}{3}$ , total entanglement entropy between  $[u_1, u_2]$  and its complement is evaluated as

$$S = \varrho(u_2 - u_1).$$

In the original coordinate  $x$ , this can be written as

$$S = \frac{\varrho}{\kappa} \ln \frac{x_2}{x_1} = \frac{1}{6} \ln \frac{x_2}{x_1}.$$

By setting  $x_1 = \epsilon_o \sim 0$  and  $x_2 = L_o \sim \infty$ , we obtain

$$S = \frac{1}{6} \ln \frac{L_o}{\epsilon_o}.$$

Here let us introduce new coordinates  $\sigma^\pm$  as

$$t \pm x = \frac{\sin\left(\frac{\pi}{L}(l - \sigma^\pm)\right)}{\sin\left(\frac{\pi}{L}\sigma^\pm\right)},$$

where  $l$  is a positive parameter satisfying  $0 < l < L$  and  $L$  is circumference of the mapped region, which is a circle. The  $S$  describes entanglement entropy between  $[0, l]$  and  $[l, L]$ . By taking  $L \rightarrow \infty$  limit, we obtain entanglement entropy of the field in open space  $(-\infty, \infty)$  between  $[0, l]$  and its complement as

$$S = \frac{1}{12} \ln \frac{l^2}{\epsilon_1 \epsilon_2}. \quad (17)$$

Here  $\epsilon_1, \epsilon_2$  are ultraviolet cutoffs defined by

$$\begin{aligned}\epsilon_o &= \frac{\pi}{L} \frac{\epsilon_2}{\sin\left(\frac{\pi l}{L}\right)}, \\ L_o &= \frac{L}{\pi \epsilon_1} \sin\left(\frac{\pi l}{L}\right).\end{aligned}$$

Let us apply the formula in Eq. (17) to the in-vacuum state of the moving mirror model.

$$S = \frac{1}{12} \ln \left( \frac{(x_2^+ - x_1^+)^2}{\epsilon_1^+ \epsilon_2^+} \right).$$

During the scattering by the mirror, entanglement is preserved. Thus we can estimate  $S$  in terms of the out states as

$$S(x_1^-, x_2^-) = \frac{1}{12} \ln \left( \frac{(f(x_2^-) - f(x_1^-))^2}{\partial f(x_2^-) \partial f(x_1^-) \epsilon_1^- \epsilon_2^-} \right),$$

where  $x_a^+ = f(x_a^-)$  and  $\epsilon_a^+ = \partial f(x_a^-) \epsilon_a^-$  for  $a = 1, 2$ . This coincides with Eq. (10).

## Appendix 2: Sudadditivity Breaking of Renormalized Entanglement Entropy

Let us consider a monotonically increasing function  $f(x)$  and three regions  $A, B, C$  given by

$$A = [0, l], B = [l, 2l], C = [2l, 3l],$$

with positive  $l$ . Then the strong subadditivity imposes

$$\Delta S_{ren} = S_{ren}^{AB} + S_{ren}^{BC} - S_{ren}^B - S_{ren}^{ABC} \geq 0, \quad (18)$$

where  $S_{ren}^{AB} = S_{ren}(0, 2l)$ ,  $S_{ren}^{BC} = S_{ren}(l, 3l)$ ,  $S_{ren}^B = S_{ren}(l, 2l)$  and  $S_{ren}^{ABC} = S_{ren}(0, 3l)$ . Since  $\Delta S_{ren}$  is computed as

$$\Delta S_{ren} = \frac{1}{6} \ln \frac{3(f(2l) - f(0))(f(3l) - f(l))}{4(f(2l) - f(l))(f(3l) - f(0))},$$

Eq. (18) means that

$$\frac{(f(2l) - f(0))(f(3l) - f(l))}{(f(2l) - f(l))(f(3l) - f(0))} \geq \frac{4}{3}.$$

However, when we assume  $f(0) = 0$  and  $f(l) = \epsilon$  with infinitesimal positive  $\epsilon$ , it is easily verified that

$$\lim_{\epsilon \rightarrow +0} \frac{(f(2l) - f(0))(f(3l) - f(l))}{(f(2l) - f(l))(f(3l) - f(0))} = 1 < \frac{4}{3}.$$

Hence the strong subadditivity of  $S_{ren}(x_1^-, x_2^-)$  is explicitly broken.

### Appendix 3: Proof of Eq. (16)

In this appendix, we prove the bound in Eq. (16). Let us assume that the state  $|\Psi\rangle \propto \hat{M}_{jE'}|0_{in}\rangle$  is a squeezed state defined by  $\hat{c}_\omega|\Psi\rangle = 0$  with annihilation operators  $\hat{c}_\omega$  satisfying  $[\hat{c}_\omega, \hat{c}_{\omega'}^\dagger] = \delta(\omega - \omega')$ . By using the in-field  $\hat{\varphi}_{in}$ ,  $\hat{c}_\omega$  is constructed as

$$\hat{c}_\omega = \frac{i}{\sqrt{\pi\omega}} \int_{-\infty}^{\infty} \exp(i\omega F(x^+)) \partial_{x^+} \hat{\varphi}_{in}(x^+) dx^+,$$

where  $F(x)$  is a monotonically increasing function satisfying  $F(\pm\infty) = \pm\infty$ . The average energy flux is computed as

$$\langle \Psi | \hat{T}_{++}(x^+) | \Psi \rangle = -\frac{1}{24\pi} \left[ \frac{\partial_x^3 F}{\partial_{x^+} F} - \frac{3}{2} \left( \frac{\partial_{x^+}^2 F}{\partial_{x^+} F} \right)^2 \right],$$

and the total energy is given by

$$E_{tot} = \int_{-\infty}^{\infty} \langle \Psi | T_{++}(x^+) | \Psi \rangle dx^+ = \frac{1}{48\pi} \int_{-\infty}^{\infty} \left( \frac{\partial_{x^+}^2 F}{\partial_{x^+} F} \right)^2 dx^+.$$

By shifting the origin of  $x^+$ , we let the  $E'$  station be at  $x^+ \leq 0$  and the shock wave with negative energy  $-rE_{fw}$  be at  $x^+ = l$ . The energy flux distribution for  $x^+ > 0$  is given by

$$\langle \Psi | \hat{T}_{++}(x^+) | \Psi \rangle = -rE_{fw} \delta(x^+ - l). \quad (19)$$

For  $x > 0$ , the most general form of  $F(x)$  satisfying Eq. (13) is solved as

$$F(x) = \frac{a + b(x-l)}{c + d(x-l)} \Theta(l-x) + \left[ \frac{a}{c} - \frac{ad-bc}{c^2}(x-l) \right] \Theta(x-l), \quad (20)$$

where  $\Theta(x)$  is the Heaviside step function, and  $a, b, c,$  and  $d$  are real parameters satisfying

$$d = 12\pi r E_{fw} c. \quad (21)$$

Note here that  $E_{tot}$  is trivially lower-bounded as

$$E_{tot} \geq \frac{1}{48\pi} \int_0^l \left( \frac{\partial_{x^+}^2 F}{\partial_{x^+} F} \right)^2 dx^+. \quad (22)$$

Substituting Eq. (20) and Eq. (21) into the right-hand side of Eq. (22) yields the following inequality:

$$E_{tot} \geq \frac{12\pi l (rE_{fw})^2}{1 - 12\pi l r E_{fw}}.$$

Defining the energy of  $E'$  as

$$E_+ = \int_{-\infty}^0 \langle \Psi | \hat{T}_{++}(x^+) | \Psi \rangle dx^+ = E_{tot} + rE_{fw},$$

we can derive the bound in Eq. (16).