

The Radial Lemma of Strauss in the Context of Morrey Spaces

Wen Yuan, Winfried Sickel and Dachun Yang*

Abstract In this paper we consider smoothness and decay properties of radial functions belonging to smoothness spaces related to Morrey spaces (Sobolev-Morrey spaces, Besov-type spaces and Besov-Morrey spaces). Within this framework we prove generalizations of the Radial Lemma of Strauss.

1 Introduction

At the end of the seventies Strauss [38] was the first who observed that there is an interplay between the regularity and decay properties of radial functions. We recall his lemma as follows.

Radial Lemma. *Let $n \geq 2$. Every radial function $f \in H^1(\mathbb{R}^n)(= W_2^1(\mathbb{R}^n))$ is almost everywhere equal to a function \tilde{f} , continuous for $x \neq 0$, such that*

$$(1.1) \quad |\tilde{f}(x)| \leq C |x|^{\frac{1-n}{2}} \|f\|_{H^1(\mathbb{R}^n)},$$

where the positive constant C depends only on n . □

Strauss stated (1.1) with the extra condition $|x| \geq 1$, but this restriction is not needed. The *Radial Lemma* contains three different assertions:

- (a) the existence of a representative of f , which is continuous outside the origin;
- (b) the decay of f near infinity;
- (c) the limited unboundedness near the origin.

2010 *Mathematics Subject Classification.* Primary 46E35, Secondary 42C15.

Key words and phrases. Smoothness of radial function, decay of radial function, Sobolev-Morrey space, Besov-type space, Besov-Morrey space.

This work is partially supported by the 2010 Joint Research Project Between China Scholarship Council and German Academic Exchange Service (PPP) (Grant No. LiuJinOu [2010]6066). Wen Yuan is supported by the Alexander von Humboldt Foundation and the National Natural Science Foundation (Grant No. 11101038) of China, and Dachun Yang is supported by the National Natural Science Foundation (Grant No. 11171027) of China and Program for Changjiang Scholars and Innovative Research Team in University of China.

*Corresponding author

These three properties do not extend to all functions in $H^1(\mathbb{R}^n)$, of course. In particular, $H^1(\mathbb{R}^n) \not\subset L^\infty(\mathbb{R}^n)$, $n \geq 2$. Taking an unbounded function $f \in H^1(\mathbb{R}^n)$, say, unbounded near the origin, by means of a simple shift $f(x - x^0)$ we obtain a function which is now unbounded around x^0 and belongs to $H^1(\mathbb{R}^n)$ as well. This makes also clear that an inequality like (1.1) can not be true in the general context.

Later on, Lions [24] showed how the *Radial Lemma* extends to first order Sobolev spaces.

Proposition 1.1. *Let $n \geq 2$ and $1 \leq p < \infty$. Every radial function $f \in W_p^1(\mathbb{R}^n)$ is almost everywhere equal to a function \tilde{f} , continuous for $x \neq 0$, such that*

$$(1.2) \quad |\tilde{f}(x)| \leq C |x|^{\frac{1-n}{p}} \|f\|_{W_p^1(\mathbb{R}^n)},$$

where the positive constant C depends only on n and p .

In recent years, after the seminal paper of Kozono and Yamazaki [19], an increasing number of papers on existence and regularity of solutions of certain partial differential equations is using Morrey spaces and smoothness spaces built on Morrey spaces (as Sobolev-Morrey spaces, Besov-Morrey spaces or Besov-type spaces). For convenience of the readers, we recall their definitions (also to fix the notation which is different in different papers).

Definition 1.2. (i) Let $0 < p \leq u \leq \infty$. The *Morrey space* $\mathcal{M}_p^u(\mathbb{R}^n)$ is defined to be the set of all p -locally Lebesgue-integrable functions f on \mathbb{R}^n such that

$$\|f\|_{\mathcal{M}_p^u(\mathbb{R}^n)} := \sup_B |B|^{1/u-1/p} \left[\int_B |f(x)|^p dx \right]^{1/p} < \infty,$$

where the supremum is taken over all balls B in \mathbb{R}^n .

(ii) Let $m \in \mathbb{N}$ and $1 \leq p \leq u \leq \infty$. The *Sobolev-Morrey space* $W^m \mathcal{M}_p^u(\mathbb{R}^n)$ is the collection of all functions $f \in \mathcal{M}_p^u(\mathbb{R}^n)$ such that all distributional derivatives $D^\alpha f$ of order $|\alpha| \leq m$ belong to $\mathcal{M}_p^u(\mathbb{R}^n)$. We equip this space with the norm

$$\|f\|_{W^m \mathcal{M}_p^u(\mathbb{R}^n)} := \sum_{|\alpha| \leq m} \|D^\alpha f\|_{\mathcal{M}_p^u(\mathbb{R}^n)}.$$

Remark 1.3. We call the parameter u in Definition 1.2 the *Morrey parameter* (also in connection with the Besov-type and Besov-Morrey spaces defined below).

Obviously we have $\mathcal{M}_p^p(\mathbb{R}^n) = L^p(\mathbb{R}^n)$ and $\mathcal{M}_p^\infty(\mathbb{R}^n) = L^\infty(\mathbb{R}^n)$. As a consequence of Hölder's inequality we conclude monotonicity with respect to p , i. e.,

$$\mathcal{M}_w^u(\mathbb{R}^n) \hookrightarrow \mathcal{M}_p^u(\mathbb{R}^n) \quad \text{if} \quad 0 < p \leq w \leq u \leq \infty.$$

In particular $L^p(\mathbb{R}^n) = \mathcal{M}_p^p(\mathbb{R}^n) \hookrightarrow \mathcal{M}_v^p(\mathbb{R}^n)$ if $v < p$. This implies that

$$W_p^m(\mathbb{R}^n) \hookrightarrow W^m \mathcal{M}_v^p(\mathbb{R}^n) \quad \text{if} \quad 1 \leq v \leq p \leq \infty.$$

For a better understanding and later use we mention also the embedding into the *class of all complex-valued, uniformly continuous and bounded functions on \mathbb{R}^n* , here denoted by $C_{ub}(\mathbb{R}^n)$. We have

$$(1.3) \quad W^m \mathcal{M}_p^u(\mathbb{R}^n) \hookrightarrow C_{ub}(\mathbb{R}^n) \quad \text{if} \quad \frac{n}{u} < m;$$

see [31, Proposition 17]. Our first result consists in an extension of Proposition 1.1 to Sobolev spaces built on Morrey spaces.

Theorem 1.4. *Let $n \geq 2$ and $1 \leq p \leq u \leq \infty$. Every radial function $f \in W^1 \mathcal{M}_p^u(\mathbb{R}^n)$ is almost everywhere equal to a function \tilde{f} , continuous for $x \neq 0$, such that*

$$(1.4) \quad |\tilde{f}(x)| \leq C |x|^{\frac{1}{p} - \frac{n}{u}} \|f\|_{W^1 \mathcal{M}_p^u(\mathbb{R}^n)}$$

holds for all $|x| \geq 1$ with some positive constant C depending only on n, p and u .

Proof. The proof is simple and (1.4) can be easily reduced to (1.2). To see this, let $f \in W^1 \mathcal{M}_p^u(\mathbb{R}^n)$ be a radial function. We choose a smooth radial cut-off function

$$\varrho \in RC_0^\infty(\mathbb{R}^n) := \{f \in C_0^\infty(\mathbb{R}^n) : f \text{ is radial}\}$$

such that $0 \leq \varrho \leq 1$, $\text{supp } \varrho \subset \{x \in \mathbb{R}^n : 1/2 < |x| < 2\}$, and $\sum_{j \in \mathbb{Z}} \varrho(2^{-j}x) = 1$ for all $x \in \mathbb{R}^n \setminus \{0\}$. Then, for all $2^k \leq |x| < 2^{k+1}$ with $k \in \mathbb{Z}$, we see that

$$f(x) = \sum_{j \in \mathbb{Z}} \varrho(2^{-j}x) f(x) = \sum_{j=k-1}^{k+1} \varrho(2^{-j}x) f(x).$$

Notice that for all $k \in \mathbb{N}_0 := \{0, 1, \dots\}$, the function $\sum_{j=k-1}^{k+1} \varrho(2^{-j} \cdot) f(\cdot)$ is a radial function in $W_p^1(\mathbb{R}^n)$ and hence by Proposition 1.1, there exists a function g_k , which is continuous on $\mathbb{R}^n \setminus \{0\}$ and coincides with $\sum_{j=k-1}^{k+1} \varrho(2^{-j} \cdot) f(\cdot)$ almost everywhere, such that for all $x \in \mathbb{R}^n$,

$$\begin{aligned} |g_k(x)| &\leq C |x|^{\frac{1-n}{p}} \sum_{j=k-1}^{k+1} \|\varrho(2^{-j} \cdot) f(\cdot)\|_{W_p^1(\mathbb{R}^n)} \\ &\leq C |x|^{\frac{1-n}{p}} \sum_{|\alpha| \leq 1} \left[\int_{2^{k-2} < |y| < 2^{k+2}} |D^\alpha (\varrho(2^{-j} \cdot) f)(y)|^p dy \right]^{1/p} \\ &\leq C \left[\max_{|\alpha| \leq 1} \|D^\alpha \varrho\|_{L^\infty(\mathbb{R}^n)} \right] |x|^{\frac{1-n}{p}} \sum_{|\alpha| \leq 1} \left[\int_{2^{k-2} < |y| < 2^{k+2}} |D^\alpha f(y)|^p dy \right]^{1/p}, \end{aligned}$$

where C is a positive constant depending only on p and n . Now we switch to the Morrey norm by inserting the volume of the ball with radius 2^{k+2} to the power $1/u - 1/p$. By ω_n

we denote the *volume of the unit ball*. Then it follows that, for all $2^k \leq |x| < 2^{k+1}$ with $k \in \mathbb{N}_0$,

$$\begin{aligned} |g_k(x)| &\leq C \left[\max_{|\alpha| \leq 1} \|D^\alpha \varrho\|_{L^\infty(\mathbb{R}^n)} \right] |x|^{\frac{1-n}{p}} \left(4^n 2^{kn} \omega_n\right)^{\frac{1}{p} - \frac{1}{u}} \|f\|_{W^1 \mathcal{M}_p^u(\mathbb{R}^n)} \\ &\leq C |x|^{\frac{1-n}{p} - \frac{n}{u}} \|f\|_{W^1 \mathcal{M}_p^u(\mathbb{R}^n)}, \end{aligned}$$

where C is a positive constant depending on p, u and n only.

Now let $\tilde{f} := \sum_{k \in \mathbb{Z}} g_k/3$. Since $\text{supp } g_k \cap \text{supp } g_j = \emptyset$ if $|j - k| \geq 5$, the summation over k is finite, and hence \tilde{f} is continuous on $\mathbb{R}^n \setminus \{0\}$ and satisfies that for all $|x| \geq 1$,

$$|\tilde{f}(x)| \leq C |x|^{\frac{1-n}{p} - \frac{n}{u}} \|f\|_{W^1 \mathcal{M}_p^u(\mathbb{R}^n)},$$

where C is a positive constant depending on p, u and n only. Moreover, since g_k coincides with $\sum_{j=k-1}^{k+1} \varrho(2^{-j} \cdot) f(\cdot)$ almost everywhere, we see that

$$\tilde{f}(x) = \sum_{k \in \mathbb{Z}} \sum_{j=k-1}^{k+1} \varrho(2^{-j} x) f(x)/3 = \sum_{j \in \mathbb{Z}} \varrho(2^{-j} x) \sum_{k=j-1}^{j+1} f(x)/3 = f(x)$$

almost every $x \in \mathbb{R}^n$. This finishes the proof of Theorem 1.4. \square

Remark 1.5. (i) Obviously the inequality (1.4) covers (1.2) (for $u = p$). Furthermore, we have decay near infinity if $1/p < n/u$. In case $1/p > n/u$ the inequality (1.4) can be immediately improved by (1.3) resulting in global boundedness of all elements of $W^1 \mathcal{M}_p^u(\mathbb{R}^n)$.

(ii) The elementary proof given above shows that we do not need all available information on the elements of $W^1 \mathcal{M}_p^u(\mathbb{R}^n)$. In fact, we only need that f belongs to $W_p^1(\mathbb{R}^n)$ locally and that

$$\sup_B |B|^{1/u-1/p} \left\{ \int_B |D^\alpha f(x)|^p dx \right\}^{1/p} < \infty, \quad |\alpha| \leq 1,$$

where the supremum is taken over all balls B , centered in the origin and having radius larger than 1. Such kind of spaces are usually called central Morrey spaces or local Morrey spaces. They attracted some attention in recent years; see, for example, [1, 5]. By this point of view it would make sense to study associated smoothness spaces. However, for the moment we concentrate on smoothness spaces related to the original Morrey norm.

The main application of the Strauss lemma and its generalizations consists in the proof of the compactness of the embedding of the radial subspace $RW_p^m(\mathbb{R}^n)$ of the Sobolev space $W_p^m(\mathbb{R}^n)$ into Lebesgue spaces $L^q(\mathbb{R}^n)$ (see, for example, [32, 35, 17, 18, 34]). Those applications are possible also for this more general situation. For this we refer to our forthcoming paper [51].

In many papers, we refer, e. g., to the survey [30] or the papers [32], [37], [6], [35] and [33], it has been shown that one gets a better insight into the behavior of radial functions if one replaces the Sobolev space $W_p^1(\mathbb{R}^n)$ by spaces of fractional order of smoothness, for

instance, Bessel potential or Besov spaces. In such a framework $H^1(\mathbb{R}^n)$ can be replaced either by $H^s(\mathbb{R}^n)$ with $s > 1/2$ or by $B_{2,1}^{1/2}(\mathbb{R}^n)$ to guarantee the same conclusions as in the Strauss Lemma above. But the Bessel potential space $H^s(\mathbb{R}^n)$ with $1/2 < s < 1$ and the Besov space $B_{2,1}^{1/2}(\mathbb{R}^n)$ are much larger than $H^1(\mathbb{R}^n)$. Indeed, we have

$$H^1(\mathbb{R}^n) \hookrightarrow H^s(\mathbb{R}^n) \hookrightarrow B_{2,1}^{1/2}(\mathbb{R}^n), \quad 1/2 < s < 1,$$

and all the embeddings are strict. The p -version looks like follows

$$W_p^1(\mathbb{R}^n) \hookrightarrow B_{p,1}^{1/p}(\mathbb{R}^n), \quad 1 < p \leq \infty,$$

and again all the embeddings are strict. This motivates the use of the more complicated spaces of fractional order of smoothness, which is also done here. Also in this much more general framework we know

$$W_p^1 \mathcal{M}_p^u(\mathbb{R}^n) \hookrightarrow B_{p,1}^{1/p, \frac{1}{p} - \frac{1}{u}}(\mathbb{R}^n), \quad 1 < p \leq u \leq \infty.$$

The main aim of this paper consists in proving the extension of Theorem 1.4 to the Besov-type spaces $B_{p,1}^{1/p, \frac{1}{p} - \frac{1}{u}}(\mathbb{R}^n)$ instead of the Sobolev-Morrey spaces.

The paper is organized as follows. In Section 2 we recall the definition and some properties of Besov-type spaces. The main part of this section is taken by a flexibilization of the known characterizations of the spaces $B_{p,q}^{s,\tau}(\mathbb{R}^n)$ by atoms. Section 3 is devoted to the investigation of the regularity of radial functions belonging to $B_{p,q}^{s,\tau}(\mathbb{R}^n)$ outside the origin. Finally, in Section 4, we study the decay of radial functions. As a service for the reader we reformulate the outcome for Sobolev-Morrey spaces in a separate subsection at the end of Section 4.

Notation

As usual, \mathbb{N} denotes the *natural numbers*, \mathbb{N}_0 the *natural numbers including 0*, \mathbb{Z} the *integers* and \mathbb{R} the *real numbers*. \mathbb{C} denotes the *complex numbers* and \mathbb{R}^n the *n -dimensional Euclidean space*. All functions are assumed to be complex-valued, i. e., we consider functions $f : \mathbb{R}^n \rightarrow \mathbb{C}$. Let $\mathcal{S}(\mathbb{R}^n)$ be the collection of all *Schwartz functions* on \mathbb{R}^n endowed with the usual topology and denote by $\mathcal{S}'(\mathbb{R}^n)$ its *topological dual*, namely, the space of all bounded linear functionals on $\mathcal{S}(\mathbb{R}^n)$ endowed with the weak $*$ -topology. The symbol $\widehat{\varphi}$ refers to the *Fourier transform* of $\varphi \in \mathcal{S}'(\mathbb{R}^n)$.

All function spaces, which we consider in this paper, are subspaces of $\mathcal{S}'(\mathbb{R}^n)$, i. e. spaces of equivalence classes with respect to almost everywhere equality. However, if such an equivalence class contains a continuous representative, then usually we work with this representative and call also the equivalence class a continuous function.

If E and F are two quasi-Banach spaces, then the *symbol* $E \hookrightarrow F$ indicates that the embedding is continuous. By $C_0^\infty(\mathbb{R}^n)$ we denote the *set of all compactly supported and infinitely differentiable functions*.

Let \mathcal{Q} be the collection of all *dyadic cubes* in \mathbb{R}^n , namely,

$$(1.5) \quad \mathcal{Q} := \{Q_{j,k} := 2^{-j}([0,1]^n + k) : j \in \mathbb{Z}, k \in \mathbb{Z}^n\}.$$

The *symbol* $\ell(Q)$ is used for the side-length of Q and $j_Q := -\log_2 \ell(Q)$. For $j \in \mathbb{Z}$, $x \in \mathbb{R}^n$, $\varphi \in \mathcal{S}(\mathbb{R}^n)$ and $Q \in \mathcal{Q}$, let $\varphi_j(x) := 2^{jn} \varphi(2^j x)$.

As usual, the *symbol* C denotes a positive constant which depends only on the fixed parameters n, s, τ, p, q and probably on auxiliary functions, unless otherwise stated; its value may vary from line to line. Sometimes we use the symbol “ \lesssim ” instead of “ \leq ”. The *meaning* of $A \lesssim B$ is given by: there exists a positive constant C such that $A \leq CB$. The *symbol* $A \asymp B$ is used as an abbreviation of $A \lesssim B \lesssim A$.

2 Besov-type spaces

Sobolev and Besov spaces have been widely used in various areas of analysis such as harmonic analysis and partial differential equations. There is a rich literature with respect to these spaces, we refer, e. g., to the monographs [2, 3, 4, 26, 40, 41, 42].

Here we would like to concentrate on Besov-type spaces which are related to a relatively new family of function spaces, so-called Q_α spaces; see, e. g., [8, 14, 44, 45]. These spaces, in general, do not coincide with Besov-Morrey spaces (Besov spaces built on Morrey spaces), but they are not so far from each other. In the following subsection we recall definitions and state some basic properties of these scales including their relations to each other. The second subsection in this section is devoted to the study of a particular atomic decomposition of the Besov-type spaces, which is adapted to the radial situation and which serves as the main tool by dealing with the smoothness and decay properties of radial functions belonging to a Besov-type space.

2.1 The definition and basic properties

We introduce the scale $B_{p,q}^{s,\tau}(\mathbb{R}^n)$ by using smooth dyadic decompositions of unity. Let $\Phi, \varphi \in \mathcal{S}(\mathbb{R}^n)$ such that

$$(2.1) \quad \text{supp } \widehat{\Phi} \subset \{\xi \in \mathbb{R}^n : |\xi| \leq 2\} \quad \text{and} \quad |\widehat{\Phi}(\xi)| \geq C > 0 \quad \text{if} \quad |\xi| \leq 5/3$$

and

$$(2.2) \quad \text{supp } \widehat{\varphi} \subset \{\xi \in \mathbb{R}^n : 1/2 \leq |\xi| \leq 2\} \quad \text{and} \quad |\widehat{\varphi}(\xi)| \geq C > 0 \quad \text{if} \quad 3/5 \leq |\xi| \leq 5/3.$$

Now we recall the notion of Besov-type spaces $B_{p,q}^{s,\tau}(\mathbb{R}^n)$; see [50, Definition 2.1].

Definition 2.1. Let $s \in \mathbb{R}$, $\tau \in [0, \infty)$, $p, q \in (0, \infty]$ and $\Phi, \varphi \in \mathcal{S}(\mathbb{R}^n)$ be as in (2.1) and (2.2), respectively. The *Besov-type space* $B_{p,q}^{s,\tau}(\mathbb{R}^n)$ is defined to be the collection of all $f \in \mathcal{S}'(\mathbb{R}^n)$ such that

$$\|f\|_{B_{p,q}^{s,\tau}(\mathbb{R}^n)} := \sup_{P \in \mathcal{Q}} \frac{1}{|P|^\tau} \left\{ \sum_{j=\max\{j_P, 0\}}^{\infty} 2^{jsq} \left[\int_P |\varphi_j * f(x)|^p dx \right]^{q/p} \right\}^{1/q} < \infty$$

with the usual modifications made in case $p = \infty$ and/or $q = \infty$, and with φ_0 replaced by Φ if $j = 0$.

Remark 2.2. (i) The *Besov-type space* $B_{p,q}^{s,\tau}(\mathbb{R}^n)$ is a complete quasi-normed space, i. e., a quasi-Banach space (see [50, Lemma 2.1]).

(ii) In case $\tau = 0$ we are back to the standard Besov spaces, i. e., $B_{p,q}^{s,0}(\mathbb{R}^n) = B_{p,q}^s(\mathbb{R}^n)$.

(iii) We have monotonicity with respect to s and with respect to q , i. e.,

$$B_{p,q_0}^{s_0,\tau}(\mathbb{R}^n) \hookrightarrow B_{p,q_1}^{s_1,\tau}(\mathbb{R}^n) \quad \text{if } s_0 > s_1 \quad \text{and} \quad 0 < q_0, q_1 \leq \infty,$$

as well as $B_{p,q_0}^{s,\tau}(\mathbb{R}^n) \hookrightarrow B_{p,q_1}^{s,\tau}(\mathbb{R}^n)$ if $q_0 \leq q_1$.

(iv) Let $s \in \mathbb{R}$ and $p \in (0, \infty]$. Then it holds that $B_{p,q}^{s,\tau}(\mathbb{R}^n) = B_{\infty,\infty}^{s+n(\tau-1/p)}(\mathbb{R}^n)$ if either $q \in (0, \infty)$ and $\tau \in (1/p, \infty)$, or $q = \infty$ and $\tau \in [1/p, \infty)$; see [49]. In case $s+n(\tau-1/p) > 0$ the space $B_{\infty,\infty}^{s+n(\tau-1/p)}(\mathbb{R}^n)$ is a Hölder-Zygmund space with a transparent description in terms of differences; see, e. g., [40, Section 2.5.7].

(v) Of course, the spaces defined above, are complicated. The definition is not really transparent. For this reason the authors have studied in [50, Section 4.3] also characterizations in terms of differences.

(vi) The Besov-type space $B_{p,q}^{s,\tau}(\mathbb{R}^n)$ and its homogeneous counterpart $\dot{B}_{p,q}^{s,\tau}(\mathbb{R}^n)$, restricted to the Banach space case, were first introduced by El Baraka in [9, 10, 11]. The extension to quasi-Banach spaces has been done in [46, 47]; see also [48, 22]. For a first systematic study we refer to the lecture note [50].

Of particular importance for us is the following embedding into the *class of all complex-valued, uniformly continuous and bounded functions on \mathbb{R}^n* , here denoted by $C_{ub}(\mathbb{R}^n)$.

Proposition 2.3. *Let $s \in \mathbb{R}$, $\tau \in [0, \infty)$ and $p, q \in (0, \infty]$*

(i) *If $s + n(\tau - 1/p) > 0$, then $B_{p,q}^{s,\tau}(\mathbb{R}^n) \hookrightarrow C_{ub}(\mathbb{R}^n)$.*

(ii) *Let $p \in (0, \infty)$, $q \in (0, \infty]$, $\tau \in (0, 1/p)$ and $s + n\tau - \frac{n}{p} = 0$. Then $B_{p,q}^{s,\tau}(\mathbb{R}^n) \not\subset C_{ub}(\mathbb{R}^n)$.*

(iii) *Let $p \in (0, \infty)$ and $q \in (0, \infty]$. Then $B_{p,q}^{0,1/p}(\mathbb{R}^n) \not\subset C_{ub}(\mathbb{R}^n)$.*

Remark 2.4. For a proof of Proposition 2.3, we refer to [50, Proposition 2.6(i)] and to [31].

For the convenience of the reader we also recall the definition of Besov-Morrey spaces as follows.

Definition 2.5. Let Φ and $\varphi \in \mathcal{S}(\mathbb{R}^n)$ be as in (2.1) and (2.2), respectively. Let $s \in \mathbb{R}$, $0 < p \leq u \leq \infty$ and $0 < q \leq \infty$. Then the *Besov-Morrey space* $\mathcal{N}_{u,p,q}^s(\mathbb{R}^n)$ is defined to be the set of all $f \in \mathcal{S}'(\mathbb{R}^n)$ such that

$$\|f\|_{\mathcal{N}_{u,p,q}^s(\mathbb{R}^n)} := \left[\sum_{j=0}^{\infty} 2^{jsq} \|\varphi_j * f\|_{\mathcal{M}_p^u(\mathbb{R}^n)}^q \right]^{1/q} < \infty$$

with the usual modifications made in case $p = \infty$ and/or $q = \infty$, and with φ_0 replaced by Φ if $j = 0$.

Remark 2.6. (i) The Besov-Morrey spaces $\mathcal{N}_{u,p,q}^s(\mathbb{R}^n)$ represent the Besov scale built on the Morrey space $\mathcal{M}_p^u(\mathbb{R}^n)$. Kozono and Yamazaki [19] in 1994 and later on Mazzucato [25] have been the first who investigated spaces of this type. In fact, they studied two, slightly different, types of spaces. The first modification consists in restricting the supremum within the definition of the Morrey norm to balls with volume ≤ 1 . Secondly, they studied homogeneous Besov-Morrey spaces $\dot{\mathcal{N}}_{u,p,q}^s(\mathbb{R}^n)$. For more information on these spaces, we refer to [19, 25, 39, 28] and the survey [31].

(ii) A further family of relatives of $B_{p,q}^{s,\tau}(\mathbb{R}^n)$ and $\mathcal{N}_{u,p,q}^s(\mathbb{R}^n)$ has been introduced and investigated by Triebel in his recent book [43].

Lemma 2.7. *Let $s \in \mathbb{R}$ and $0 < p \leq u \leq \infty$.*

(i) *If $q \in (0, \infty)$, then $\mathcal{N}_{u,p,q}^s(\mathbb{R}^n) \hookrightarrow B_{p,q}^{s, \frac{1}{p} - \frac{1}{u}}(\mathbb{R}^n)$.*

(ii) *It also holds that $\mathcal{N}_{u,p,\infty}^s(\mathbb{R}^n) = B_{p,\infty}^{s, \frac{1}{p} - \frac{1}{u}}(\mathbb{R}^n)$ in the sense of equivalent quasi-norms.*

(iii) *Let $m \in \mathbb{N}_0$ and $1 \leq p \leq u < \infty$. Then*

$$\mathcal{N}_{u,p,\min(2,p)}^m(\mathbb{R}^n) \hookrightarrow W^m \mathcal{M}_p^u(\mathbb{R}^n) \hookrightarrow \mathcal{N}_{u,p,\infty}^m(\mathbb{R}^n).$$

Remark 2.8. Lemma 2.7(i) and (ii) have been proved in [29]; see also [31, Proposition 7]. There the authors argued with atomic decompositions. In addition they have been able to show that the embedding in Lemma 2.7(i) is proper if $p < u$. Concerning part (iii) of Lemma 2.7 we refer to Sawano [27] and [31, Lemma 5].

2.2 Radial subspaces

Let U be an isometry of \mathbb{R}^n and $g \in \mathcal{S}(\mathbb{R}^n)$. Then we define $g^U(x) := g(Ux)$, $x \in \mathbb{R}^n$. For $f \in \mathcal{S}'(\mathbb{R}^n)$ we put

$$f^U(g) := f(g^{U^{-1}}), \quad g \in \mathcal{S}(\mathbb{R}^n),$$

where U^{-1} denotes the isometry inverse to U . Then f^U is also a distribution in $\mathcal{S}'(\mathbb{R}^n)$.

Let $SO(\mathbb{R}^n)$ be the group of rotations around the origin in \mathbb{R}^n . We say that $f \in \mathcal{S}'(\mathbb{R}^n)$ is invariant with respect to $SO(\mathbb{R}^n)$ if $f^U = f$ for all $U \in SO(\mathbb{R}^n)$. Now we are able to define the radial subspaces which we are interested in.

Definition 2.9. Let s, τ, p and q be as in Definition 2.1. The radial subspace $RB_{p,q}^{s,\tau}(\mathbb{R}^n)$ of the space $B_{p,q}^{s,\tau}(\mathbb{R}^n)$ is defined by

$$RB_{p,q}^{s,\tau}(\mathbb{R}^n) := \{f \in B_{p,q}^{s,\tau}(\mathbb{R}^n) : f \text{ is invariant with respect to } SO(\mathbb{R}^n)\}.$$

Since the linear operator $T_U f := f^U - f$ is bounded on $B_{p,q}^{s,\tau}(\mathbb{R}^n)$ for all $U \in SO(\mathbb{R}^n)$ and

$$RB_{p,q}^{s,\tau}(\mathbb{R}^n) = \bigcap_{U \in SO(\mathbb{R}^n)} \text{Ker } T_U,$$

we know that $RB_{p,q}^{s,\tau}(\mathbb{R}^n)$ is a closed subspace of $B_{p,q}^{s,\tau}(\mathbb{R}^n)$, and hence a quasi-Banach space with respect to the induced quasi-norm.

2.3 Atomic decompositions

As mentioned above our main tool in all our investigations is the description of these radial subspaces $RB_{p,q}^{s,\tau}(\mathbb{R}^n)$ by means of atoms. Starting point is a rather general characterization of $B_{p,q}^{s,\tau}(\mathbb{R}^n)$ in terms of atoms. Since this is, in a certain sense, parallel to what has been done in Frazier and Jawerth [15, 16] and also [32], we shifted this more technical part to the Appendix at the end of this paper.

Atomic decompositions are always connected with a sequence of coverings of \mathbb{R}^n . Here we are interested in a very special sequence adapted to the radial situation. To begin with we recall some notions; see Skrzypczak in [36], but also [32, Definition 1]. The notion of an atom, we are using here, represents a certain modification of the definition given in Frazier and Jawerth [15, 16]. For any open set $Q \subset \mathbb{R}^n$ and any $r \in (0, \infty)$, we put $rQ := \{x \in \mathbb{R}^n : \text{dist}(x, Q) < r\}$. Also we use the abbreviation $p' := p/(p-1)$ if $1 < p \leq \infty$ and $p' := \infty$ if $0 < p \leq 1$.

Definition 2.10. Let $s \in \mathbb{R}$, $p \in (0, \infty]$, $r \in (0, \infty)$, L and M be integers such that $L \geq 0$ and $M \geq -1$. Assume that $Q \subset \mathbb{R}^n$ is an open connected set with $\text{diam } Q = r$.

(i) A smooth function a is called an 1_L -atom centered in Q if $\text{supp } a \subset \frac{r}{2}Q$ and

$$\sup_{y \in \mathbb{R}^n} |\partial^\alpha a(y)| \leq 1 \quad \text{for } |\alpha| \leq L.$$

(ii) A smooth function a is called an $(s, p)_{L, M}$ -atom centered in Q if $\text{supp } a \subset \frac{r}{2}Q$,

$$\sup_{y \in \mathbb{R}^n} |\partial^\alpha a(y)| \leq r^{s-|\alpha|-\frac{n}{p}} \quad \text{for } |\alpha| \leq L$$

and

$$\left| \int_{\mathbb{R}^n} a(y) \varphi(y) dy \right| \leq r^{s+M+1+n/p'} \|\varphi\|_{C^{M+1}(\overline{rQ})}$$

for all $\varphi \in C^\infty(\mathbb{R}^n)$, where $\|\varphi\|_{C^{M+1}(\overline{rQ})} := \sup_{x \in \overline{rQ}} \sup_{|\alpha| \leq M+1} |\partial^\alpha \varphi(x)|$.

Remark 2.11. We recall that when $M = -1$, then the second condition in Definition 2.10(ii) is void. Of certain use is the following simple observation: if a is an $(s_0, p)_{L, M}$ -atom, then $r^{s_1-s_0} a$ is also an $(s_1, p)_{L, M}$ -atom.

Regular coverings

We follow [32]. Let $\{Q_\ell\}_\ell$ be a covering of \mathbb{R}^n by connected open sets Q_ℓ . We put

$$C_Q := \sup_{x \in \mathbb{R}^n} |\{\ell : Q_\ell \text{ contains } x\}|$$

(here $|\cdot|$ denotes the *cardinality* of the set). We call this number the *multiplicity of the covering* $\{Q_\ell\}_\ell$. A covering with finite multiplicity is called *uniformly locally finite*. Let $(\Omega_j := \{Q_{j,\ell}\}_{\ell=0}^\infty)_{j=0}^\infty$ be a sequence of uniformly locally finite coverings of \mathbb{R}^n . The supremum of multiplicities of the coverings Ω_j , $j \in \mathbb{N}_0$, is called the *multiplicity of the sequence* $(\Omega_j)_{j=0}^\infty$.

Definition 2.12. A sequence $(\Omega_j)_{j=0}^\infty := (\{\Omega_{j,\ell}\}_{\ell=0}^\infty)_{j=0}^\infty$ of coverings of \mathbb{R}^n is *regular* if the following conditions are satisfied:

- (i) $\mathbb{R}^n \subset \cup_{\ell \in \mathbb{N}_0} \overline{\Omega_{j,\ell}}$ for all $j \in \mathbb{N}_0$;
- (ii) there exists some positive number ε_0 such that for all $\varepsilon \in (0, \varepsilon_0)$, the sequences of coverings $\{\varepsilon 2^{-j} \Omega_{j,\ell}\}_{\ell=0}^\infty$ have finite multiplicity with uniform bound of multiplicity with respect to ε ;
- (iii) there exist positive numbers B_n and C_n , depending only on the dimension n , such that $\text{diam } \Omega_{j,\ell} \leq B_n 2^{-j}$ and $C_n 2^{-jn} \leq |\Omega_{j,\ell}|$.

Remark 2.13. (i) By ω_n we denote the *volume of the unit ball in \mathbb{R}^n* . Let $A_n := (C_n/\omega_n)^{1/n}$. Then Definition 2.12(iii) implies that $A_n 2^{-j} \leq \text{diam } \Omega_{j,\ell} \leq B_n 2^{-j}$ and

$$C_n 2^{-jn} \leq |\Omega_{j,\ell}| \leq B_n^n \omega_n 2^{-jn}$$

for all j and all ℓ .

- (ii) If $(\{\Omega_{j,\ell}\}_{\ell=0}^\infty)_{j=0}^\infty$ is a regular sequence of coverings, the cardinality of the sets,

$$I_{j,\ell} := \{k : \Omega_{j,\ell} \cap \Omega_{j,k} \neq \emptyset\}, \quad j, k \in \mathbb{N}_0,$$

is uniformly bounded; see [32, Lemma 1].

Next we define some sequence spaces with respect to a regular sequence $(\{\Omega_{j,\ell}\}_{\ell=0}^\infty)_{j=0}^\infty$ of coverings.

Definition 2.14. Let $\tau \in [0, \infty)$ and $p, q \in (0, \infty]$. Let $\Omega := (\{\Omega_{j,\ell}\}_{\ell=0}^\infty)_{j=0}^\infty$ be a regular sequence of coverings. Then the sequence space $b(p, q, \tau, \Omega)$ is defined to be the set of all sequences $t := \{t_{j,\ell}\}_{j,\ell=0}^\infty \subset \mathbb{C}$ such that

$$\|t\|_{b(p,q,\tau,\Omega)} := \sup_{P \in \mathcal{Q}} \frac{1}{|P|^\tau} \left\{ \sum_{j=\max\{j_P, 0\}}^\infty \left[\sum_{\substack{\ell \in \mathbb{N}_0 \\ \Omega_{j,\ell} \cap P \neq \emptyset}} |t_{j,\ell}|^p \right]^{q/p} \right\}^{1/q} < \infty.$$

Remark 2.15. In case $\tau < 1/p$, the replacement of the sum $\sum_{j=\max\{j_P, 0\}}^\infty$ in Definition 2.14 by $\sum_{j=0}^\infty$ yields an equivalent quasi-norm. For a proof we refer to [29].

Regular coverings and associated atomic decompositions

The spaces $B_{p,q}^{s,\tau}(\mathbb{R}^n)$ are said to admit an atomic decomposition with respect to the sequence $(\{\Omega_{j,\ell}\}_{\ell=0}^\infty)_{j=0}^\infty$ if there exist integers L and M such that

- (i) any $f \in B_{p,q}^{s,\tau}(\mathbb{R}^n)$ can be represented by

$$(2.3) \quad f = \sum_{j=0}^\infty \sum_{\ell=0}^\infty t_{j,\ell} a_{j,\ell}$$

in $\mathcal{S}'(\mathbb{R}^n)$, where $a_{0,\ell}$ is an 1_L -atom centered at the set $\Omega_{0,\ell}$, $a_{j,\ell}$ with $j \in \mathbb{N}$ is an $(s, p)_{L, M}$ -atom centered at the set $\Omega_{j,\ell}$, and $\{t_{j,\ell}\}_{j,\ell \in \mathbb{N}_0}$ is a sequence of complex numbers satisfying that

$$(2.4) \quad \|\{t_{j,\ell}\}_{j,\ell \in \mathbb{N}_0}\|_{b(p,q,\tau,\Omega)} < \infty;$$

(ii) any $f \in \mathcal{S}'(\mathbb{R}^n)$ given by (2.3) with (2.4) is an element of $B_{p,q}^{s,\tau}(\mathbb{R}^n)$;

(iii) the infimum of (2.4) with respect to all admissible representations of f is an equivalent norm in $B_{p,q}^{s,\tau}(\mathbb{R}^n)$.

Next we show that if $\{\Omega_j\}_{j=0}^\infty$ is a regular sequence of coverings, then for some L and M , the spaces $B_{p,q}^{s,\tau}(\mathbb{R}^n)$ admit an atomic decomposition with respect to $\{\Omega_j\}_{j=0}^\infty$. In what follows, the symbol $\lfloor \alpha \rfloor$ for any $\alpha \in \mathbb{R}$ denotes the maximal integer not more than α .

Theorem 2.16. *Let $s \in \mathbb{R}$, $\tau \in [0, \infty)$ and $p, q \in (0, \infty]$. Let $\{\Omega_j\}_{j=0}^\infty$ be a regular sequence of coverings and let L and M be integers such that*

$$L \geq \max\{\lfloor s + n\tau \rfloor + 1, 0\} \quad \text{and} \quad M \geq \max\{\lfloor \sigma_p - s \rfloor, -1\},$$

where $\sigma_p := n(\max\{0, 1/p - 1\})$. Then the spaces $B_{p,q}^{s,\tau}(\mathbb{R}^n)$ admit an atomic decomposition with respect to $\{\Omega_j\}_{j=0}^\infty$.

Remark 2.17. This theorem represents an extension of the well-known characterizations by atoms discussed in Frazier and Jawerth [15, 16]. More exactly, choosing

$$\Omega_j := \{Q_{j,k} : k \in \mathbb{Z}^n\}, \quad j \in \mathbb{N}_0$$

(see (1.5)) and $\tau = 0$, then Theorem 2.16 has been proved in the quoted papers by Frazier and Jawerth. Regular coverings and related atomic decompositions, also restricted to $\tau = 0$, have been discussed in [32]; see also [37]. Atomic decompositions of Besov-type spaces have been investigated in [50] and [23]. Our proof of Theorem 2.16 is more or less parallel to those given in the quoted papers. For that reason we shift it into the Appendix at the end of this paper.

2.4 Atomic decompositions of radial subspaces

Now we make use of the flexibility in the choice of the regular coverings. In [32, Section 3.2] Sickel and Skrzypczak constructed a sequence of regular coverings which is well adapted to the radial situation.

A basic role in this construction is played by the following shells (balls if $k = 0$):

$$P_{j,k} := \{x \in \mathbb{R}^n : k2^{-j} \leq |x| < (k+1)2^{-j}\}, \quad j, k \in \mathbb{N}_0.$$

Lemma 2.18. *Let $n \geq 2$. There exists a regular sequence*

$$(\Omega_j^R)_{j \in \mathbb{N}_0} := (\{\Omega_{j,k,\ell}^R\}_{k \in \mathbb{N}_0, \ell \in \{1, \dots, C(n,k)\}})_{j \in \mathbb{N}_0}$$

of coverings with finite multiplicity satisfying that

(a) all $\Omega_{j,k,\ell}^R$ are balls with centers $y_{j,k,\ell}$ satisfying that

$$|y_{j,k,\ell}| = \begin{cases} 2^{-j} (k + 1/2) & \text{if } k \in \mathbb{N}, \\ 0 & \text{if } k = 0; \end{cases}$$

(b)

$$P_{j,k} \subset \bigcup_{\ell=1}^{C(n,k)} \Omega_{j,k,\ell}^R, \quad j \in \mathbb{N}_0;$$

(c) $\text{diam } \Omega_{j,k,\ell}^R = 12 \cdot 2^{-j}$;

(d) the sums

$$\sum_{k=0}^{\infty} \sum_{\ell=1}^{C(n,k)} \chi_{j,k,\ell}(x)$$

are uniformly bounded in $x \in \mathbb{R}^n$ and $j \in \mathbb{N}_0$ (here $\chi_{j,k,\ell}$ denotes the characteristic function of $\Omega_{j,k,\ell}^R$);

(e)

$$\Omega_{j,k,\ell}^R = \{x \in \mathbb{R}^n : 2^j x \in \Omega_{0,k,\ell}^R\}, \quad j \in \mathbb{N}_0;$$

(f) $C(n, 0) = 1$, $C(n, k) \in \mathbb{N}$ and $C(n, k) \asymp k^{n-1}$, when $k \in \mathbb{N}$;

(g) with an appropriate enumeration it holds that

$$\{(x_1, 0, \dots, 0) : x_1 \geq 0\} \subset \bigcup_{k=0}^{\infty} \Omega_{j,k,1}^R$$

and

$$|\{(x_1, 0, \dots, 0) : x_1 \in \mathbb{R}\} \cap \Omega_{j,k,1}^R| \asymp 2^{-j}.$$

(h) for all $k \in \mathbb{N}$ and $\ell \in \{1, \dots, C(n, k)\}$ there exists an element $U_{k,\ell} \in SO(\mathbb{R}^n)$ such that $\Omega_{j,k,\ell}^R = U_{k,\ell}(\Omega_{j,k,1}^R)$;

(i) Let $\varepsilon \in (0, \varepsilon_0)$. Then the multiplicity of the sequence

$$\left(\{\varepsilon \Omega_{j,k,\ell}^R : \ell \in \{1, \dots, C(n, k)\}, k \in \mathbb{N}_0\} \right)_{j \in \mathbb{N}_0}$$

is finite with multiplicity constant independent of ε .

If $k = 0$, we sometimes use the notation $\Omega_{j,0}^R$ to replace $\Omega_{j,0,1}^R$. Lemma 2.18(g) is not stated explicitly in [32] but it follows immediately from the construction described there; see also [20]. Most transparent is the case $n = 2$. Here is a picture.

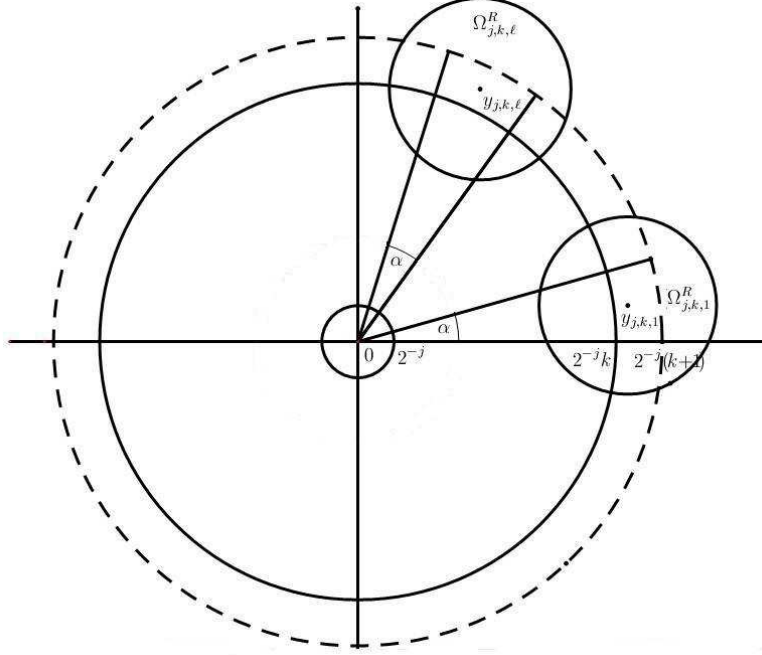

Fig.1 A piece of the covering $(\Omega_{j,k,\ell}^R)_{j=0}^\infty$ in the case $n = 2$

Here the angle α is taken to be $(2\pi)/(2k + 1)$, $k \in \mathbb{N}$.

Applying Theorem 2.16 and Lemma 2.18, we obtain the atomic decomposition of radial spaces. We use the following abbreviation

$$\omega(P, j, k) := |\{\ell : 1 \leq \ell \leq C(n, k) \text{ and } \Omega_{j,k,\ell}^R \cap P \neq \emptyset\}|.$$

Obviously, $0 \leq \omega(P, j, 0) \leq 1$ for all j and all dyadic cubes P .

Theorem 2.19. *Let $n \geq 2$, $s \in \mathbb{R}$, $\tau \in [0, \infty)$ and $p, q \in (0, \infty]$, integers L, M satisfying*

$$L \geq \max\{[s + n\tau] + 1, 0\} \quad \text{and} \quad M \geq \max\{[\sigma_p - s], -1\},$$

and $(\Omega_j^R)_{j \in \mathbb{N}_0} := (\{\Omega_{j,k,\ell}^R\}_{k \in \mathbb{N}_0, \ell \in \{1, \dots, C(n,k)\}})_{j \in \mathbb{N}_0}$ be as in Lemma 2.18.

- (i) *The space $RB_{p,q}^{s,\tau}(\mathbb{R}^n)$ admits an atomic decomposition with respect to $(\Omega_j^R)_{j \in \mathbb{N}_0}$.*
- (ii) *If $f \in RB_{p,q}^{s,\tau}(\mathbb{R}^n)$, then f admits an atomic decomposition*

$$(2.5) \quad f = \sum_{j=0}^{\infty} t_{j,0} a_{j,0} + \sum_{j=0}^{\infty} \sum_{k=1}^{\infty} t_{j,k} \sum_{\ell=1}^{C(n,k)} a_{j,k,\ell},$$

where $a_{j,k,\ell}$ is an $(s, p)_{L,M}$ -atom with respect to $\Omega_{j,k,\ell}^R$ for all $j \in \mathbb{N}$, $a_{j,0}$ an $(s, p)_{L,M}$ -atom with respect to $\Omega_{j,0}^R$ for all $j \in \mathbb{N}$, $a_{0,k,\ell}$ an 1_L -atom with respect to $\Omega_{0,k,\ell}^R$, $a_{0,0}$ an 1_L -atom with respect to $\Omega_{0,0}^R$ and

$$(2.6) \quad \sup_{P \in \mathcal{Q}} \frac{1}{|P|^\tau} \left\{ \sum_{j=\max\{j_P, 0\}}^{\infty} \left[\sum_{k=0}^{\infty} \omega(P, j, k) |t_{j,k}|^p \right]^{\frac{q}{p}} \right\}^{\frac{1}{q}} \leq C \|f\|_{B_{p,q}^{s,\tau}(\mathbb{R}^n)}.$$

Here C is a positive constant independent of f .

Proof. Part (i) is an immediate consequence of Theorem 2.16 and Lemma 2.18. Concerning (ii) we employ the particular decomposition constructed in Step 1 of the proof of Theorem 2.16. Rewriting (5.1) we obtain

$$t_{j,k,\ell} := \begin{cases} D(n, M) \sup_{y \in \Omega_{0,k,\ell}^R} |\Phi * f(y)|, & \text{if } j = 0; \\ E(n, M) 2^{j(s-n/p)} \sup_{y \in \Omega_{j,k,\ell}^R} |\varphi_j * f(y)|, & \text{if } j \in \mathbb{N}. \end{cases}$$

Since $\Phi * f$ and $\varphi_j * f$ are radial functions if f , Φ and φ are radial, we conclude by using Lemma 2.18(h) of our regular covering that

$$t_{j,k,\ell} = t_{j,k,1} \quad \text{for all } j, k, \ell.$$

This proves (ii) and hence finishes the proof of Theorem 2.19. \square

Remark 2.20. Epperson and Frazier [12, 13] independently developed a theory of radial subspaces of Besov and Triebel-Lizorkin spaces. They preferred to work with atomic decompositions, where the atoms themselves are radial. We did not follow their treatment here but sometimes this different point of view has some advantages.

3 On the smoothness of radial functions outside the origin

To begin with we study the continuity of radial functions outside the origin. As usual, we call an element f of $B_{p,q}^{s,\tau}(\mathbb{R}^n)$ continuous if it has a continuous representative.

Before we start to investigate this problem we explain how we use the atomic decomposition in (2.5). This is also of some importance for all other proofs here. The main feature is the local structure in the following sense. Let f be given by (2.5), i. e.,

$$f = \sum_{j=0}^{\infty} t_{j,0} a_{j,0} + \sum_{j=0}^{\infty} \sum_{k=1}^{\infty} t_{j,k} \sum_{\ell=1}^{C(n,k)} a_{j,k,\ell},$$

We fix $|x| \geq 1$. Observe that for all $j \in \mathbb{N}_0$ there exists $k_j \in \mathbb{N}$ such that

$$(3.1) \quad k_j 2^{-j} \leq |x| < (k_j + 1) 2^{-j}.$$

Then, employing the restrictions on the supports of our atoms, we see that $f(x)$ is given by

$$\sum_{|r_j| \leq N} \sum_{|t_j| \leq N} \sum_{j=0}^{\infty} t_{j,k_j+r_j} a_{j,k_j+r_j,\ell_j+t_j}(x),$$

where $N \in \mathbb{N}$ is a universal number independent of f and x . Here ℓ_j depends on x . To avoid technicalities we simply deal in our investigations with the function

$$(3.2) \quad f^P(x) = \sum_{j=0}^{\infty} s_{j,k_j} a_{j,k_j,\ell_j}(x)$$

instead of f itself. In case $0 < |x| < 1$ these arguments have to be modified. Let

$$(3.3) \quad 2^{-j_0} \leq |x| < 2^{-j_0+1}$$

for some $j_0 \in \mathbb{N}$. Then we deal with the function

$$(3.4) \quad f^P(x) := \sum_{j=0}^{j_0-1} s_{j,0} a_{j,0}(x) + \sum_{j=j_0}^{\infty} s_{j,k_j} a_{j,k_j,\ell_j}(x),$$

as a replacement of f at the point x . Here k_j is defined as in (3.1).

Theorem 3.1. *Let $n \geq 2$, $p \in (0, \infty)$ and $\tau \in [0, \infty)$. Let either $s > 1/p$ and $q \in (0, \infty]$, or $s = 1/p$ and $q \in (0, 1]$. Every radial element f in $B_{p,q}^{s,\tau}(\mathbb{R}^n)$ has a representative \tilde{f} which is continuous outside of the origin.*

Proof. Step 1. Let $\tau \geq 1/p$. Then by [50, Proposition 2.6], we know that

$$B_{p,q}^{s,\tau}(\mathbb{R}^n) \hookrightarrow B_{\infty,\infty}^s(\mathbb{R}^n) \quad \text{if } s > 0.$$

Hence, all functions in $B_{p,q}^{s,\tau}(\mathbb{R}^n)$ are continuous on \mathbb{R}^n , not only the radial functions.

Step 2. Suppose $0 \leq \tau < 1/p$. By monotonicity of the spaces $B_{p,q}^{s,\tau}(\mathbb{R}^n)$ (see Remark 2.2), it is enough to deal with $B_{p,1}^{\frac{1}{p},\tau}(\mathbb{R}^n)$.

Substep 2.1. Let $|x| \geq 1$. We investigate the sequence

$$S_N f^P(x) := \sum_{j=0}^N s_{j,k_j} a_{j,k_j,\ell_j}(x), \quad N \in \mathbb{N}.$$

Since our atoms are at least continuous, also $S_N f^P$ is continuous. Furthermore, employing the normalization of our atoms (see Definition 2.10), we find that

$$|S_N f^P(x)| \leq \sum_{j=0}^N 2^{-j(s-n/p)} |t_{j,k_j}| = \sum_{j=0}^N (k_j)^{\frac{1-n}{p}} 2^{-j(s-n/p)} (k_j^{n-1} |t_{j,k_j}|^p)^{1/p}.$$

Let P be the smallest dyadic cube containing all points $(k_j + 1) 2^{-j} x/|x|$, $j \in \mathbb{N}_0$, and 0. Hence

$$|P| \asymp |x|^n \asymp (k_j + 1)^n 2^{-jn} \quad \text{and} \quad \omega(P, j, k_j) \asymp C(n, k_j) \asymp k_j^{n-1},$$

since $k_j \in \mathbb{N}$. We add a short explanation for the last relation. Take x such that all components are nonnegative. Let $2^L < (k_j + 1)2^{-j} \leq 2^{L+1}$. Then $P = Q_{-L,0}$ (see (1.5)), and contains the part of the shell (3.1) which is contained in

$$\{y = (y_1, \dots, y_n) : y_i \geq 0 \text{ for all } i\}.$$

By the uniform distribution of the balls $\Omega_{j,k_j,\ell}^R$ on the shell this implies that

$$|\{\ell : P \cap \Omega_{j,k_j,\ell}^R\}| \asymp \frac{C(n, k_j)}{2^n}.$$

Since we ignore the dependence on n the claim follows. This results in

$$\begin{aligned} (3.5) \quad |S_N f^P(x)| &\lesssim \sum_{j=0}^N (k_j)^{\frac{1-n}{p}} 2^{-j(s-n/p)} \left[\sum_{\ell=1}^{\infty} \omega(P, j, \ell) |t_{j,\ell}|^p \right]^{1/p} \\ &\lesssim |x|^{n\tau} \frac{|x|^{\frac{1-n}{p}}}{|P|^\tau} \sum_{j=0}^{\infty} 2^{-j(s-1/p)} \left[\sum_{\ell=1}^{\infty} \omega(P, j, \ell) |t_{j,\ell}|^p \right]^{1/p} \\ &\lesssim |x|^{\frac{1-n}{p} + n\tau} \|f\|_{B_{p,1}^{\frac{1}{p}, \tau}(\mathbb{R}^n)}, \end{aligned}$$

where the last inequality follows from (2.6). Here the constant behind \lesssim does not depend on f and x . Practically the same set of inequalities as in (3.5) yields

$$|S_{N_1+N_2} f^P(x) - S_{N_1} f^P(x)| \lesssim \frac{|x|^{\frac{1-n}{p}}}{|P|^\tau} \sum_{j=N_1}^{\infty} 2^{-j(s-1/p)} \left[\sum_{\ell=1}^{\infty} \omega(P, j, \ell) |t_{j,\ell}|^p \right]^{1/p} \lesssim \varepsilon,$$

if N_1 is sufficiently large (depending on ε and $|x|$) and $N_2 \in \mathbb{N}$ is arbitrary. Let $b > 1$. Then this implies uniform convergence of the sequence $S_N f^P$ on any shell $\{x \in \mathbb{R}^n : 1 < |x| \leq b\}$ to a continuous limit. Coming back to the original situation we obtain the continuity of f on these regions, which means on $|x| \geq 1$.

Substep 2.2. Let $|x| < 1$. The arguments are similar with a few modifications. There exists a natural number j_0 such that $2^{-j_0} \leq |x| < 2^{-j_0+1}$.

We work with

$$S_N f^P(x) := \sum_{j=0}^{j_0-1} t_{j,0} a_{j,0}(x) + \sum_{j=j_0}^N t_{j,k_j} a_{j,k_j,\ell_j}(x), \quad N \geq j_0,$$

instead of f itself. As in the previous substep we obtain

$$|S_N f^P(x)| \leq \sum_{j=0}^{j_0-1} 2^{-j(s-n/p)} |t_{j,0}| + \sum_{j=j_0}^N 2^{-j(s-n/p)} |t_{j,k_j}|.$$

To estimate the second sum on the right-hand side we argue as in Substep 2.1. Indeed, let P be the smallest dyadic cube containing $(k_j + 1)2^{-j}x/|x|$, $j \in \mathbb{N}_0$, $2^{-j_0+1}x/|x|$ and 0. Then

$$|P| \asymp |x|^n \asymp 2^{-j_0 n} \quad \text{and} \quad \omega(P, j, k_j) \asymp C(n, k_j) \asymp k_j^{n-1}, \quad j \geq j_0.$$

Thus, repeating the argument in Substep 2.1, we conclude that

$$\sum_{j=j_0}^N 2^{-j(s-n/p)} |t_{j,k_j}| \lesssim |x|^{\frac{1-n}{p}+n\tau} \|f\|_{B_{p,1}^{1/p,\tau}(\mathbb{R}^n)}$$

with a positive constant behind \lesssim independent of f , N , j_0 and x . Observe that for all $j \in \mathbb{N}_0$,

$$|t_{j,0}| \lesssim 2^{-jn\tau} \|f\|_{B_{p,1}^{1/p,\tau}(\mathbb{R}^n)};$$

see (2.6). We choose P as above and use $\omega(P, j, 0) = 1$. By means of this inequality, we obtain

$$\sum_{j=0}^{j_0-1} 2^{-j(1/p-n/p)} |t_{j,0}| \lesssim \|f\|_{B_{p,1}^{1/p,\tau}(\mathbb{R}^n)} \sum_{j=0}^{j_0-1} 2^{-j(1/p-n/p+n\tau)}.$$

An easy calculation yields

$$\begin{aligned} \sum_{j=0}^{j_0-1} 2^{-j(1/p-n/p+n\tau)} &\lesssim \begin{cases} 1, & \tau \in (\frac{n-1}{np}, \frac{1}{p}]; \\ j_0, & \tau = \frac{n-1}{np}; \\ 2^{-j_0(1/p-n/p+n\tau)}, & \tau \in [0, \frac{n-1}{np}) \end{cases} \\ &\asymp \begin{cases} 1, & \tau \in (\frac{n-1}{np}, \frac{1}{p}]; \\ 1 - \log_2 |x|, & \tau = \frac{n-1}{np}; \\ |x|^{\frac{1-n}{p}+n\tau}, & \tau \in [0, \frac{n-1}{np}). \end{cases} \end{aligned}$$

Summarizing, we have found the estimate

$$(3.6) \quad |S_N f^P(x)| \leq w(|x|, \tau) \|f\|_{B_{p,1}^{1/p,\tau}(\mathbb{R}^n)},$$

where

$$w(|x|, \tau) := \begin{cases} 1, & \tau \in (\frac{n-1}{np}, \frac{1}{p}]; \\ 1 - \log_2 |x|, & \tau = \frac{n-1}{np}; \\ |x|^{\frac{1-n}{p}+n\tau}, & \tau \in [0, \frac{n-1}{np}). \end{cases}$$

Having established this estimate we may proceed as at the end of Substep 2.1 to convert it into the continuity of f in all shells (3.3), $j \in \mathbb{N}$. The proof is complete. \square

Remark 3.2. (i) For fixed p and τ the largest space $B_{p,q}^{s,\tau}(\mathbb{R}^n)$ with the indicated property in Theorem 3.1 is given by $B_{p,1}^{1/p,\tau}(\mathbb{R}^n)$; see Remark 2.2 and Proposition 2.3.

(ii) As mentioned in the introduction this result has many forerunners in case $\tau = 0$. Let us mention Strauss [38] ($H^1(\mathbb{R}^n) = W_2^1(\mathbb{R}^n) = B_{2,2}^1(\mathbb{R}^n)$), Lions [24] ($W_p^1(\mathbb{R}^n)$) and Sickel and Skrzypczak [32] (general case with $\tau = 0$). A much more detailed analysis of the smoothness of radial functions belonging to some Besov or Triebel-Lizorkin spaces has been given in Sickel, Skrzypczak and Vybiral [35]. In particular it is shown there that,

in case $\tau = 0$, the results are unimprovable within the scale $B_{p,q}^s(\mathbb{R}^n)$. More exactly, in $B_{p,q}^{1/p}(\mathbb{R}^n)$, $q > 1$, there exist radial and unbounded functions f such that

$$\text{supp } f \subset \{x \in \mathbb{R}^n : a < |x| < b\}, \quad 0 < a < b < \infty.$$

Here a and b are at our disposal.

4 Decay near infinity and controlled unboundedness near the origin of radial functions

The proof of Theorem 3.1 allows some immediate conclusions about the pointwise behaviour of radial functions. Observe that, under the restrictions of Theorem 3.1, our radial functions in $B_{p,q}^{s,\tau}(\mathbb{R}^n)$ are continuous outside the origin, hence pointwise inequalities make sense.

Theorem 4.1. *Let $n \geq 2$ and $p \in (0, \infty)$.*

(i) *Let $\tau \in (\frac{n-1}{np}, \infty)$, $s + n(\tau - 1/p) > 0$ and $q \in (0, \infty]$. Then there exists a positive constant C such that for all $f \in RB_{p,q}^{s,\tau}(\mathbb{R}^n)$ and all $x \in \mathbb{R}^n$, it holds that*

$$(4.1) \quad |f(x)| \leq C \|f\|_{B_{p,q}^{s,\tau}(\mathbb{R}^n)}.$$

(ii) *Let $\tau \in [0, \frac{n-1}{np}]$. Let either $s > 1/p$ and $q \in (0, \infty]$, or $s = 1/p$ and $q \in (0, 1]$. Then there exists a positive constant C such that for all $f \in RB_{p,q}^{s,\tau}(\mathbb{R}^n)$ and all $|x| \geq 1$, it holds that*

$$(4.2) \quad |f(x)| \leq C \|f\|_{B_{p,q}^{s,\tau}(\mathbb{R}^n)} |x|^{\frac{1-n}{p} + n\tau}.$$

(iii) *Let $\tau \in [0, \frac{n-1}{np}]$. Let either $s > 1/p$ and $q \in (0, \infty]$, or $s = 1/p$ and $q \in (0, 1]$. In addition, assume that $s \leq n(\frac{1}{p} - \tau)$. Then there exists a positive constant C such that for all $f \in RB_{p,q}^{s,\tau}(\mathbb{R}^n)$ and all x , $0 < |x| < 1$, it holds that*

$$(4.3) \quad |f(x)| \leq C \|f\|_{B_{p,q}^{s,\tau}(\mathbb{R}^n)} \begin{cases} 1 - \log_2 |x|, & \tau = \frac{n-1}{np}; \\ |x|^{\frac{1-n}{p} + n\tau}, & \tau \in [0, \frac{n-1}{np}). \end{cases}$$

Proof. Step 1. Proof of (i). For the results from the continuous embedding of $B_{p,q}^{s,\tau}(\mathbb{R}^n)$ into a certain Hölder-Zygmund space if $s + n(\tau - 1/p) > 0$, see Proposition 2.3. Of course, the restriction to radial functions is superfluous here.

Step 2. Part (ii) follows from the estimate (3.5) in combination with the embeddings for Besov-type spaces mentioned in Remark 2.2.

Step 3. Part (iii) follows from the estimate (3.6), again in combination with the embeddings for Besov-type spaces mentioned in Remark 2.2. \square

Remark 4.2. (i) Let us shortly comment on the behavior near infinity. It is an easy exercise in Fourier analysis to check that the function $f \equiv 1$ belongs to $B_{p,q}^{s,\tau}(\mathbb{R}^n)$ if and

only if $0 < p \leq \infty$, $\tau \geq 1/p$, $s \in \mathbb{R}$ and $0 < q \leq \infty$. Since this function is radial it is immediate that functions belonging to $RB_{p,q}^{s,\tau}(\mathbb{R}^n)$ need not have decay near infinity. With this respect the inequality (4.1) is optimal in case $\tau \geq 1/p$. Next we consider the particular case $\tau = \frac{n-1}{np}$. Then we have

$$\frac{1-n}{p} + n\tau = 0 \quad \text{and} \quad s + n(\tau - 1/p) > 0 \quad \iff \quad s > \frac{1}{p}.$$

Hence, the passage from Theorem 4.1(i) (global boundedness and no decay) to Theorem 4.1(ii) (decay near infinity) is “continuous”.

(ii) We comment on the behavior near the origin. First of all, let us mention that in case $s > n(\frac{1}{p} - \tau)$ we have global boundedness of all functions in $B_{p,q}^{s,\tau}(\mathbb{R}^n)$. Hence, the assumption $s \leq n(\frac{1}{p} - \tau)$ in Theorem 4.1(iii) is natural in our context. In case $\tau = 0$ and $s = n/p$ one knows even more about the behavior of radial functions near the origin; see [35]. For $\tau \in [0, \frac{n-1}{np})$ the bound near infinity is also the bound near the origin, decay near infinity of order $|x|^{\frac{1-n}{p} + n\tau}$ becomes controlled unboundedness of order $|x|^{\frac{1-n}{p} + n\tau}$ near the origin. Again the limiting situation $\tau = \frac{n-1}{np}$ is of certain interest. Then singularities of logarithmic order are possible.

(iii) For fixed p and τ the largest space $B_{p,q}^{s,\tau}(\mathbb{R}^n)$ in (ii) and (iii) of Theorem 4.1 is given by $B_{p,1}^{1/p,\tau}(\mathbb{R}^n)$; see Remark 2.2.

(iv) There is a number of references with respect to the classical case $\tau = 0$. Following Strauss [38] and Coleman, Glazer and Martin [7], who had proved the inequality (4.2) for radial functions belonging to $W_2^1(\mathbb{R}^n)$, P.L. Lions [24] gave the extension to all first order Sobolev spaces $W_p^1(\mathbb{R}^n)$. The extension to Besov spaces and in particular, the existence of a bound for s for the validity of these statements have been found in Sickel and Skrzypczak [32]. More detailed investigations have been undertaken in Sickel, Skrzypczak and Vybiral [35]. Let us refer also to Cho and Ozawa [6]. These authors deal with $H^s(\mathbb{R}^n) = B_{2,2}^s(\mathbb{R}^n)$, $s > 1/2$, using methods from Fourier analysis. The advantage of this approach consists in its simplicity and the fact that more information about the constant C in (4.2) is given. In the framework of Morrey spaces those investigations seem to be new.

(v) Decay properties of functions under symmetry conditions have been investigated at several places. We refer to Lions [24], Kuzin and Pohozaev [21], Skrzypczak [37] and the references given there. There also different types of symmetry constraints are investigated, e.g., block radial symmetry.

Next we turn to the questions around sharpness in Theorem 4.1. Here we have some partial answers.

Proposition 4.3. *Let $p \in (0, \infty)$ and $\tau \in [0, \infty)$.*

(i) *Let $p > \frac{n-1}{n}$ and $\tau \in [0, \frac{n-1}{np}]$. Assume that either $s < 1/p$ and $q \in (0, \infty]$, or $s = 1/p$ and $q \in (1, \infty]$. Then for all $|x| \geq 1$, there exists a sequence $\{f_N\}_{N \in \mathbb{N}}$ of smooth and compactly supported radial functions, depending on x , such that $\|f_N\|_{B_{p,q}^{s,\tau}(\mathbb{R}^n)} = 1$ and $\lim_{N \rightarrow \infty} |f_N(x)| = \infty$.*

(ii) Let $s < 1/p$ and $q \in (0, \infty]$. Then there exist a sequence $\{x_N\}_{N \in \mathbb{N}}$ of points in \mathbb{R}^n and a corresponding sequence $\{f_N\}_{N \in \mathbb{N}}$ of smooth and compactly supported radial functions such that $x_N \rightarrow 0$, $\|f_N\|_{B_{p,q}^{s,\tau}(\mathbb{R}^n)} \leq 1$ and $|f_N(x_N)| \geq N|x_N|^{\frac{1-n}{p}-n\tau}$.

Proof. Step 1. Proof of (i). We follow ideas used in [32, pp.651-653]. Let $\psi \in C_0^\infty(\mathbb{R}^n)$ such that $0 \leq \psi \leq 1$, $\psi(x) = 1$ if $|x| \leq 12$ and $\psi(x) = 0$ if $|x| \geq 13$. Denote by $y_{j,k,\ell}$ the center of the ball $\Omega_{j,k,\ell}^R$ and let

$$\tilde{\psi}_{j,0}(\cdot) := \psi(2^j \cdot) \quad \text{and} \quad \tilde{\psi}_{j,k,\ell}(\cdot) := \psi(2^j(\cdot - y_{j,k,\ell}))$$

for all $j \in \mathbb{N}_0$, $k \in \mathbb{N}$ and $\ell \in \{1, \dots, C(n, k)\}$. Then by Lemma 2.18, we see that

$$1 \leq \tilde{\psi}_{j,0} + \sum_{k \in \mathbb{N}} \sum_{\ell=1}^{C(n,k)} \tilde{\psi}_{j,k,\ell} \leq M m_0,$$

where m_0 denotes the multiplicity of the sequence of coverings, $\{\Omega_{j,k,\ell}^R\}_\ell$, and M is a positive constant independent of j . Define

$$\psi_{j,0} := \frac{\tilde{\psi}_{j,0}}{\tilde{\psi}_{j,0} + \sum_{m \in \mathbb{N}} \sum_{r=1}^{C(n,m)} \tilde{\psi}_{j,m,r}}$$

and

$$\psi_{j,k,\ell} := \frac{\tilde{\psi}_{j,k,\ell}}{\tilde{\psi}_{j,0} + \sum_{m \in \mathbb{N}} \sum_{r=1}^{C(n,m)} \tilde{\psi}_{j,m,r}}.$$

Then

$$\psi_{j,0} + \sum_{m \in \mathbb{N}} \sum_{r=1}^{C(n,m)} \psi_{j,m,r} \equiv 1.$$

Let $\psi_0 \in C^\infty([0, \infty))$ be such that $0 \leq \psi_0 \leq 1$, $\psi_0(x) = 1$ if $0 \leq x \leq 1$ and $\psi_0(x) = 0$ if $x \geq 2$. Define

$$\varphi_{j,r}(x) := \psi_0(|2^j|x| - 2^r|), \quad x \in \mathbb{R}^n,$$

for all $j, r \in \mathbb{Z}$. Obviously, these functions are radial,

$$(4.4) \quad \text{supp } \varphi_{j,r} \subset \{x \in \mathbb{R}^n : \max(0, 2^{-j}(2^r - 2)) \leq |x| \leq 2^{-j}(2 + 2^r)\},$$

and

$$(4.5) \quad \varphi_{j,r}(x) = 1 \quad \text{if} \quad |x| = 2^{r-j}.$$

For this family of functions it has been proved in [32, p.652] that

$$\varphi_{j,r} = \sum_{k=2^r-r_0}^{2^r+r_0} \sum_{\ell=1}^{C(n,k)} \psi_{j,k,\ell} \varphi_{j,r} \quad \text{if} \quad r \geq \max(j+4, 5),$$

where r_0 is independent of j and r . Assume that $n(\max\{0, \frac{1}{p} - 1\}) < s < 1/p$. In this region no moment conditions are needed for our atoms. For some positive constant C_1 , the functions $C_1 2^{-j(s-n/p)} \psi_{j,k,\ell} \varphi_{j,r}$ are $(s, p)_{L, -1}$ -atoms with respect to $\Omega_{j,k,\ell}^R$; see [32, p. 652]. Then by Theorem 2.19 we know that

$$(4.6) \quad \begin{aligned} \|\varphi_{j,r}\|_{B_{p,q}^{s,\tau}(\mathbb{R}^n)} &= \left\| \sum_{k=2^r-r_0}^{2^r+r_0} \sum_{\ell=1}^{C(n,k)} \psi_{j,k,\ell} \varphi_{j,r} \right\|_{B_{p,q}^{s,\tau}(\mathbb{R}^n)} \\ &\asymp \sup_{\substack{P \in \mathcal{Q} \\ j_P \leq j}} \frac{1}{|P|^\tau} \left[\sum_{k=2^r-r_0}^{2^r+r_0} \omega(P, j, k) 2^{j(s-n/p)p} \right]^{1/p}; \end{aligned}$$

see (2.6). From our knowledge about the support of $\varphi_{j,r}$ (see (4.4)), it becomes clear that the supremum is realized by dyadic cubes with side-length $\leq C(2^r + r_0)2^{-j}$ for some positive constant C independent of r and j . Hence, the supremum in the previous formula runs only over those dyadic cubes P such that

$$2^{-j} \leq \ell(P) \lesssim (2^r + r_0)2^{-j} \lesssim 2^{r-j}.$$

If $j_P = j - m$ for some $m \in \mathbb{N}_0$, then for those cubes m satisfies $0 \lesssim m \lesssim r$. Finally, the number of balls $\Omega_{j,k,\ell}^R$ satisfying $\Omega_{j,k,\ell}^R \cap P \neq \emptyset$ is at most a constant multiple of $2^{m(n-1)}$, i. e.,

$$(4.7) \quad \omega(P, j, k) \lesssim 2^{m(n-1)}.$$

To prove this claim we proceed as follows. Let $12P_{j,k}$ denote the the annulus

$$\left\{ x \in \mathbb{R}^n : \left(k - \frac{11}{2} \right) 2^{-j} \leq |x| < \left(k + \frac{13}{2} \right) 2^{-j} \right\} \quad \text{if } k > \frac{11}{2},$$

or the ball $B(0, (k + \frac{13}{2})2^{-j})$ if $k \leq \frac{11}{2}$. From $\text{diam } \Omega_{j,k,\ell}^R = 12 \cdot 2^{-j}$ and the position of the centers $y_{j,k,\ell}$ of the balls $\Omega_{j,k,\ell}^R$ in Lemma 2.18(a), we deduce that

$$\bigcup_{\ell=1}^{C(n,k)} \Omega_{j,k,\ell}^R \subset 12P_{j,k}.$$

On the other hand, notice that the volume of $P \cap (12P_{j,k})$ is at most a constant multiple of $2^{-j} \times 2^{-j_P(n-1)} = 2^{-jn} 2^{m(n-1)}$ (which can be attained in the case $\text{diam}(P \cap 12P_{j,k}) \asymp \sqrt{n} \ell(P)$). Since $|\Omega_{j,k,\ell}^R| \asymp 2^{-jn}$ and $\{\Omega_{j,k,\ell}^R\}_{\ell \in \{1, \dots, C(n,k)\}}$ is of finite multiplicity, it follows that there exists at most a constant multiple of $2^{m(n-1)}$ balls in $\{\Omega_{j,k,\ell}^R\}_{\ell \in \{1, \dots, C(n,k)\}}$ such that

$$\Omega_{j,k,\ell}^R \cap P = \Omega_{j,k,\ell}^R \cap (P \cap 12P_{j,k}) \neq \emptyset.$$

Thus, (4.7) holds true. In the picture below we draw a cube P , $\ell(P) = 2^{-j_P} > 2^{-j}$ in a position, where $\omega(P, j, k)$ becomes maximal within the family of dyadic cubes Q of side-length 2^{-j_P} .

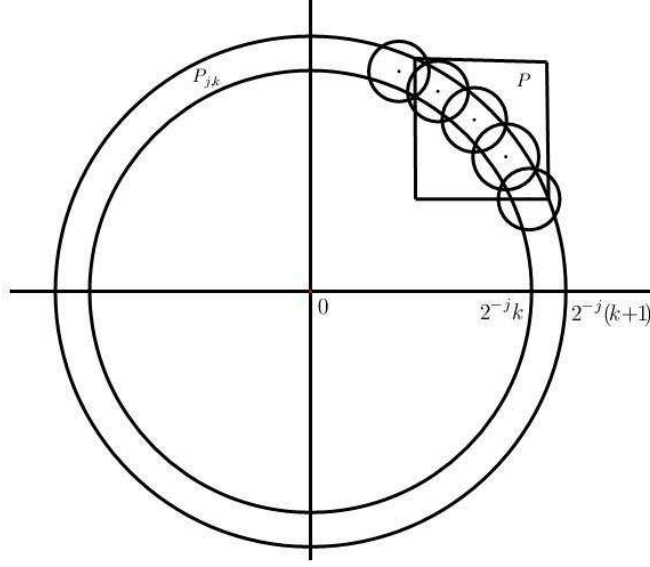

Fig.2 A dyadic cube P in a position with $\omega(P, j, k)$ large

Therefore, employing $\tau \leq (n-1)/(np)$, (4.6) and (4.7), we obtain

$$\|\varphi_{j,r}\|_{B_{p,q}^{s,\tau}(\mathbb{R}^n)} \lesssim \sup_{0 \leq m \lesssim r} 2^{(j-m)n\tau} 2^{j(s-n/p)} 2^{m(n-1)/p} \asymp 2^{j(s-n/p+n\tau)} 2^{r(\frac{n-1}{p}-n\tau)}.$$

Now we turn to a new normalization

$$\|2^{-j(s-n/p+n\tau)} 2^{-r(\frac{n-1}{p}-n\tau)} \varphi_{j,r}\|_{B_{p,q}^{s,\tau}(\mathbb{R}^n)} \leq 1,$$

but, thanks to (4.5), we find that

$$\begin{aligned} 2^{-j(s-n/p+n\tau)} 2^{-r(\frac{n-1}{p}-n\tau)} \varphi_{j,r}((2^{r-j}, 0, \dots, 0)) &= 2^{-j(s-n/p+n\tau)} 2^{-r(\frac{n-1}{p}-n\tau)} \\ &= 2^{j(1/p-s)} 2^{(r-j)(-\frac{n-1}{p}+n\tau)}. \end{aligned}$$

Let $|x| := 2^t$ for some $t \geq 5$. We apply the preceding formulas with $t := r-j$ fixed and j tending to infinity. This proves the desired result in the case of dyadic values of $|x|$. The general case $|x| \geq 1$ follows from using the same arguments with some simple modifications. Moreover, from the monotonicity of the quasi-norms with respect to s and q , we also obtain the result in the case $s \leq n(\max\{0, 1/p-1\})$.

Now we consider the case that $s = 1/p$ and $q \in (1, \infty]$. By the assumption on p we know that $s > n(\max\{0, 1/p-1\})$, which means that the atoms in Theorem 2.19 do not need to satisfy moment conditions. Let

$$\varphi_{N,r} = \sum_{j=1}^N \alpha_j \varphi_{j,j+4+r}, \quad N \in \mathbb{N}, \quad r \geq 0,$$

where $\{\alpha_j\}_j$ is a sequence of positive numbers such that $\{\alpha_j\}_j \in \ell^q$ but $\{\alpha_j\}_j \notin \ell^1$. Then, similar to the above argument in case $s < 1/p$, we see that

$$\|\varphi_{N,r}\|_{B_{p,q}^{s,\tau}(\mathbb{R}^n)} \asymp \sup_{P \in \mathcal{Q}} \frac{1}{|P|^\tau} \left\{ \sum_{j=\max(j_P,1)}^N \alpha_j^q \left[\sum_{k=2^{j+4+r-r_0}}^{2^{j+4+r+r_0}} \omega(P,j,k) 2^{j(1-n)} \right]^{q/p} \right\}^{1/q}.$$

Arguing as above, in the supremum only those dyadic cubes P , such that $2^{-N} \leq \ell(P) \lesssim 2^r$, are of relevance; see (4.4). Thus, $-r \lesssim j_P \leq N$. By the same argument as used in (4.7), we see that, for all $j \geq j_P$, $\omega(P,j,k) \lesssim 2^{(j-j_P)(n-1)}$. Therefore, it follows from $\tau \in [0, \frac{n-1}{np}]$ that

$$\|\varphi_{N,r}\|_{B_{p,q}^{s,\tau}(\mathbb{R}^n)} \lesssim \sup_{\substack{P \in \mathcal{Q} \\ -r \lesssim j_P \leq N}} 2^{j_P[n\tau - (n-1)/p]} \left\{ \sum_{j=\max(j_P,1)}^N \alpha_j^q \right\}^{1/q} \lesssim 2^{r(\frac{n-1}{p} - n\tau)} \left\{ \sum_{j=1}^N \alpha_j^q \right\}^{1/q}.$$

Next, observe that

$$\varphi_{N,r}((2^{r+4}, 0, \dots, 0)) = \sum_{j=1}^N \alpha_j \rightarrow \infty \quad \text{as } N \rightarrow \infty;$$

see (4.5). By taking r fixed, but letting N tend to infinity, this finishes the proof for the case of dyadic values of $|x|$. The general case $|x| \geq 1$ follows from some simple modifications.

Step 2. Proof of (ii). Assume first that $n(\max\{0, 1/p - 1\}) < s < 1/p$. Since $2^{-j(s-n/p)}\varphi_{j,0}$ is a constant multiple of an $(s, p)_{L,-1}$ -atom with respect to $\Omega_{j,0}^R$, Theorem 2.19 yields

$$\|2^{-jn\tau} 2^{-j(s-n/p)}\varphi_{j,0}\|_{B_{p,q}^{s,\tau}(\mathbb{R}^n)} \lesssim 1.$$

Considering the function $2^{-jn\tau} 2^{-j(s-n/p)}\varphi_{j,0}$ on the ring $|x| = 2^{-j}$, we know that

$$2^{-jn\tau} 2^{-j(s-n/p)}|\varphi_{j,0}(x)| = |x|^{s-n/p+n\tau} \geq N|x|^{\frac{1-n}{p}+n\tau}$$

when $|x|$ is small enough. The general case $s < 1/p$ follows from a monotonicity argument. This finishes the proof of Proposition 4.3. \square

Remark 4.4. (i) Combining Proposition 4.3 and Theorem 4.1(ii), we know that the inequality (4.2) can not be true if either $s < 1/p$ and q arbitrary, or $s = 1/p$ and $1 < q \leq \infty$.

(ii) Proposition 4.3(ii) in combination with Theorem 4.1(iii) yields that in case $s < 1/p$ the inequality (4.3) can not be true.

(iii) In case $\tau = 0$ a much more detailed investigation of the sharpness of the results has been undertaken in [35]. However, the approach used there is based on a characterization of the trace spaces of $RB_{p,q}^s(\mathbb{R}^n)$. That would be of certain interest also in the present situation.

Smoothness outside the origin, decay near infinity and controlled unboundedness of radial functions belonging to Sobolev-Morrey spaces

For the convenience of the reader we formulate the consequences of Theorem 3.1, Theorem 4.1 and Proposition 4.3 in case of Sobolev-Morrey spaces. Applying the embedding

$$(4.8) \quad W^m \mathcal{M}_p^u(\mathbb{R}^n) \hookrightarrow \mathcal{N}_{u,p,\infty}^m(\mathbb{R}^n) = B_{p,\infty}^{m,\tau}(\mathbb{R}^n), \quad \tau = \frac{1}{p} - \frac{1}{u},$$

and Theorem 3.1, we have the following result.

Corollary 4.5. *Let $n \geq 2$, $1 < p \leq u < \infty$ and $m \in \mathbb{N}$. Every radial element f in $W^m \mathcal{M}_p^u(\mathbb{R}^n)$ has a representative f which is continuous outside of the origin.*

The next result follows from (4.8) and Theorem 4.1.

Corollary 4.6. *Let $n \geq 2$, $1 < p \leq u < \infty$ and $m \in \mathbb{N}$.*

(i) *Let $u/p \leq n$. Then there exists a positive constant C such that for all $f \in RW^m \mathcal{M}_p^u(\mathbb{R}^n)$ and all $|x| \geq 1$, it holds that*

$$(4.9) \quad |f(x)| \leq C \|f\|_{W^m \mathcal{M}_p^u(\mathbb{R}^n)} |x|^{\frac{1}{p} - \frac{n}{u}}.$$

(ii) *Let $u/p \leq n$. Then there exists a positive constant C such that for all $f \in RW^m \mathcal{M}_p^u(\mathbb{R}^n)$ and all x with $0 < |x| < 1$, it holds that*

$$(4.10) \quad |f(x)| \leq C \|f\|_{W^m \mathcal{M}_p^u(\mathbb{R}^n)} \begin{cases} 1 - \log_2 |x|, & \frac{1}{p} = \frac{n}{u}; \\ |x|^{\frac{1}{p} - \frac{n}{u}}, & \frac{1}{p} < \frac{n}{u}. \end{cases}$$

Remark 4.7. Let us mention that because of the embedding (1.3) only those situations are of interest where $n \geq u$ holds. Of course, part (i) of Corollary 4.6 represents Theorem 1.4 proved in a totally different way.

5 Appendix - Proof of Theorem 2.16

Step 1. Recall that $B_{p,q}^{s,\tau}(\mathbb{R}^n) = B_{\infty,\infty}^{s+n(\tau-1/p)}(\mathbb{R}^n)$ if either $q \in (0, \infty)$ and $\tau \in (1/p, \infty)$, or $q = \infty$ and $\tau \in [1/p, \infty)$ (see [49]). The desired conclusion in the above case and in case $\tau = 0$ has been given in [32, Proposition 1].

Step 2. Next we assume that either $\tau \in (0, 1/p)$ and $q \in (0, \infty]$, or $\tau = 1/p$ and $q \in (0, \infty)$.

Substep 2.1. Let $f \in B_{p,q}^{s,\tau}(\mathbb{R}^n)$ be given. We show the existence of an appropriate atomic decomposition. Let $\Psi, \psi \in \mathcal{S}(\mathbb{R}^n)$ be such that

$$|\widehat{\Psi}(\xi)| > 0 \quad \text{if } |\xi| \leq 2 \quad \text{and} \quad |\widehat{\psi}(\xi)| > 0 \quad \text{if } 1/2 \leq |\xi| \leq 2.$$

Then there exist $\Phi, \varphi \in \mathcal{S}(\mathbb{R}^n)$ and $\delta \in (0, \infty)$ such that

$$\text{supp } \widehat{\Phi} \subset \{\xi \in \mathbb{R}^n : |\xi| \leq 2\} \quad \text{and} \quad |\widehat{\Phi}(\xi)| > 0 \quad \text{if } |\xi| \leq \delta,$$

φ satisfies (2.2), and

$$\widehat{\Psi}(\xi)\overline{\widehat{\Phi}(\xi)} + \sum_{j \in \mathbb{N}} \widehat{\psi}(2^{-j}\xi)\overline{\widehat{\varphi}(2^{-j}\xi)} = 1$$

for all $\xi \in \mathbb{R}^n$; see Frazier and Jawerth [15, 16]. Let A_n be the same as in Remark 2.13. In addition we may assume that

$$\text{supp } \Psi, \quad \text{supp } \psi \subset \{x \in \mathbb{R}^n : |x| \leq A_n/2\}$$

and

$$\int_{\mathbb{R}^n} x^\gamma \psi(x) dx = 0 \quad \text{for all } |\gamma| \leq M;$$

see [32, Proposition 1]. Then, by the Calderón reproducing formula, we see that

$$f(x) = \int_{\mathbb{R}^n} \Psi(x-y) \widetilde{\Phi} * f(y) dy + \sum_{j \in \mathbb{N}} \int_{\mathbb{R}^n} \psi_j(x-y) \widetilde{\varphi}_j * f(y) dy$$

in $\mathcal{S}'(\mathbb{R}^n)$, where $\widetilde{\Phi}(\cdot) = \overline{\Phi(-\cdot)}$ and $\widetilde{\varphi}_j(\cdot) = \overline{\varphi_j(-\cdot)}$. For all $j, \ell \in \mathbb{N}_0$, we define

$$(5.1) \quad t_{j,\ell} := \begin{cases} D(n, M) \sup_{y \in \Omega_{0,\ell}} |\widetilde{\Phi} * f(y)|, & j = 0; \\ E(n, M) 2^{j(s-n/p)} \sup_{y \in \Omega_{j,\ell}} |\widetilde{\varphi}_j * f(y)|, & j \in \mathbb{N}, \end{cases}$$

where

$$D(n, M) := B_n^n w_n \left[\max_{|\alpha| \leq L} \|D^\alpha \Psi\|_{C(\mathbb{R}^n)} \right]$$

and

$$E(n, M) := B_n^n w_n \left[\max_{|\alpha| \leq L} \|D^\alpha \psi\|_{C(\mathbb{R}^n)} \right] \\ \times \max_{|\alpha| \leq L} \left\{ A_n^{-s+n/p+|\alpha|}, B_n^{-s+n/p+|\alpha|} \right\} \max \left\{ 1, w_n (3/2)^{M+n+1} \sum_{|\gamma|=M+1} \frac{1}{\gamma!} \right\}.$$

As in [32, Proposition 1], for all $j \in \mathbb{N}_0$, we let $\Omega_{j,0}^* := \Omega_{j,0}$ and

$$\Omega_{j,\ell}^* := \Omega_{j,\ell} \setminus \left(\bigcup_{m=0}^{\ell-1} \Omega_{j,m} \right) \quad \text{if } \ell \in \mathbb{N}.$$

Then $\{\Omega_{j,\ell}^*\}_{\ell \in \mathbb{N}_0}$ is a family of pairwise disjoint sets and satisfies that $\bigcup_{\ell \in \mathbb{N}_0} \Omega_{j,\ell}^* = \mathbb{R}^n$ for all $j \in \mathbb{N}_0$. When $t_{j,\ell} \neq 0$ we let

$$(5.2) \quad a_{j,\ell}(x) := \begin{cases} \frac{1}{t_{0,\ell}} \int_{\Omega_{0,\ell}^*} \Psi(x-y) \widetilde{\Phi} * f(y) dy, & j = 0; \\ \frac{1}{t_{j,\ell}} \int_{\Omega_{j,\ell}^*} \psi_j(x-y) \widetilde{\varphi}_j * f(y) dy, & j \in \mathbb{N}. \end{cases}$$

When $t_{j,\ell} = 0$ we define $a_{j,\ell}(x) \equiv 0$. Then, by the argument used in the proof of [32, Proposition 1], we know that $a_{0,\ell}$ is an 1_L -atom centered at the set $\Omega_{0,\ell}$, $a_{j,\ell}$ with $j \in \mathbb{N}$ an $(s,p)_{L,M}$ -atom centered at the set $\Omega_{j,\ell}$ and $f = \sum_{j=0}^{\infty} \sum_{\ell=0}^{\infty} t_{j,\ell} a_{j,\ell}$ in $\mathcal{S}'(\mathbb{R}^n)$. Now we prove that

$$(5.3) \quad \|\{t_{j,\ell}\}_{j,\ell \in \mathbb{N}_0}\|_{b(p,q,\tau,\Omega)} \lesssim \|f\|_{B_{p,q}^{s,\tau}(\mathbb{R}^n)}.$$

By definition of the $t_{j,\ell}$, we find that

$$\begin{aligned} & \|\{t_{j,\ell}\}_{j,\ell \in \mathbb{N}_0}\|_{b(p,q,\tau,\Omega)} \\ & \asymp \sup_{P \in \mathcal{Q}} \frac{1}{|P|^\tau} \left\{ \sum_{j=\max\{j_P,0\}}^{\infty} 2^{j(s-n/p)q} \left[\sum_{\substack{\ell \in \mathbb{N}_0 \\ \Omega_{j,\ell} \cap P \neq \emptyset}} \sup_{y \in \Omega_{j,\ell}} |\tilde{\varphi}_j * f(y)|^p \right]^{q/p} \right\}^{1/q}. \end{aligned}$$

Similar to the argument used in the proof of [15, (2.11)], we conclude that

$$\sup_{y \in \Omega_{j,\ell}} |\tilde{\varphi}_j * f(y)|^p \lesssim 2^{jn} \sum_{k \in \mathbb{Z}^n} (1+|k|)^{-N} \int_{\Omega_{j,\ell}} |\tilde{\varphi}_j * f(y + 2^{-j}k)|^p dy,$$

where N is at our disposal. On the other hand, since $\text{diam } \Omega_{j,\ell} \leq B_n 2^{-j}$, there exists a constant $d \in [1, \infty)$ such that, for all $j \geq j_P$,

$$\bigcup_{\substack{\ell \in \mathbb{N}_0 \\ \Omega_{j,\ell} \cap P \neq \emptyset}} \Omega_{j,\ell} \subset dP.$$

Denote by y_P the center of P and by $B(y, R)$ the ball with radius R and center in y . It follows that

$$\begin{aligned} & \|\{t_{j,\ell}\}_{j,\ell \in \mathbb{N}_0}\|_{b(p,q,\tau,\Omega)} \\ & \lesssim \sup_{P \in \mathcal{Q}} \frac{1}{|P|^\tau} \left\{ \sum_{j=\max\{j_P,0\}}^{\infty} 2^{jsq} \left[\sum_{\substack{\ell \in \mathbb{N}_0 \\ \Omega_{j,\ell} \cap P \neq \emptyset}} \sum_{k \in \mathbb{Z}^n} \frac{\int_{\Omega_{j,\ell}} |\tilde{\varphi}_j * f(y + 2^{-j}k)|^p dy}{(1+|k|)^N} \right]^{q/p} \right\}^{1/q} \\ & \lesssim \sup_{P \in \mathcal{Q}} \frac{1}{|P|^\tau} \left\{ \sum_{j=\max\{j_P,0\}}^{\infty} 2^{jsq} \left[\sum_{k \in \mathbb{Z}^n} \frac{\int_{dP} |\tilde{\varphi}_j * f(y + 2^{-j}k)|^p dy}{(1+|k|)^N} \right]^{q/p} \right\}^{1/q} \\ & \lesssim \sup_{P \in \mathcal{Q}} \frac{1}{|P|^\tau} \left\{ \sum_{j=\max\{j_P,0\}}^{\infty} 2^{jsq} \left[\sum_{k \in \mathbb{Z}^n} \frac{\int_{B(y_P, d\ell(P)+|k|\ell(P))} |\tilde{\varphi}_j * f(z)|^p dz}{(1+|k|)^N} \right]^{q/p} \right\}^{1/q}. \end{aligned}$$

Temporarily we assume $q \leq p$. By the definition of $\|f\|_{B_{p,q}^{s,\tau}(\mathbb{R}^n)}$, we conclude that

$$\|\{t_{j,\ell}\}_{j,\ell \in \mathbb{N}_0}\|_{b(p,q,\tau,\Omega)}$$

$$\begin{aligned}
&\lesssim \sup_{P \in \mathcal{Q}} \frac{1}{|P|^\tau} \left\{ \sum_{k \in \mathbb{Z}^n} (1 + |k|)^{-Nq/p} \right. \\
&\quad \times \left. \sum_{j=\max\{j_P, 0\}}^{\infty} 2^{jsq} \left[\int_{B(y_P, d\ell(P) + |k|\ell(P))} |\tilde{\varphi}_j * f(z)|^p dz \right]^{q/p} \right\}^{1/q} \\
&\lesssim \|f\|_{B_{p,q}^{s,\tau}(\mathbb{R}^n)} \left\{ \sum_{k \in \mathbb{Z}^n} (1 + |k|)^{-Nq/p} (d + |k|)^{n\tau q} \right\}^{1/q} \lesssim \|f\|_{B_{p,q}^{s,\tau}(\mathbb{R}^n)},
\end{aligned}$$

where we have chosen $N > n(\tau+1/q)p$. Now we turn to the case $q > p$. With $N > n(\tau p+1)$ we obtain

$$\begin{aligned}
&\|\{t_{j,\ell}\}_{j,\ell \in \mathbb{N}_0}\|_{b(p,q,\tau,\Omega)} \\
&\lesssim \left\{ \sum_{k \in \mathbb{Z}^n} (1 + |k|)^{-N} \right. \\
&\quad \times \left. \sup_{P \in \mathcal{Q}} \frac{1}{|P|^{\tau p}} \left[\sum_{j=\max\{j_P, 0\}}^{\infty} 2^{jsq} \left[\int_{B(y_P, d\ell(P) + |k|\ell(P))} |\tilde{\varphi}_j * f(z)|^p dz \right]^{q/p} \right]^{p/q} \right\}^{1/p} \\
&\lesssim \|f\|_{B_{p,q}^{s,\tau}(\mathbb{R}^n)} \left\{ \sum_{k \in \mathbb{Z}^n} (1 + |k|)^{-N} (d + |k|)^{n\tau p} \right\}^{1/q} \lesssim \|f\|_{B_{p,q}^{s,\tau}(\mathbb{R}^n)}.
\end{aligned}$$

Hence, we have proved that any $f \in B_{p,q}^{s,\tau}(\mathbb{R}^n)$ admits an atomic decompositions with respect to the sequence of coverings $(\{\Omega_{j,\ell}\}_\ell)_j$ such that (5.3) holds with some constants behind \lesssim independent of f .

Substep 2.2. Now we study the regularity of appropriate atomic decompositions with coefficient sequence belonging to $b(p, q, \tau, \Omega)$. Associated to the sequence of coverings $(\{\Omega_{j,\ell}\}_\ell)_j$ there is a regular sequence of coverings by balls $(\{B_{j,\ell}\}_\ell)_j$ such that

$$\Omega_{j,\ell} \subset B_{j,\ell}, \quad j \in \mathbb{N}_0, \quad \ell \in \mathbb{N}_0;$$

see [32, Proposition 1]. Any atomic decomposition with respect to $(\{\Omega_{j,\ell}\}_\ell)_j$ represents trivially an atomic decomposition with respect to $(\{B_{j,\ell}\}_\ell)_j$. But for such a standard covering the desired property is known to be true, we refer to [50, Theorem 3.3]. Let us mention that this has been the only place, where we use $\tau \leq 1/p$ in Step 2. This finishes the proof of Theorem 2.16.

References

- [1] J. Alvarez, J. Lakey and M. Guzmán-Partida, Spaces of bounded λ -central mean oscillation, Morrey spaces, and λ -central Carleson measures, *Collect. Math.* **51** (2000), 1-47.

- [2] J. Bergh and J. Löfström, *Interpolation Spaces. An Introduction*, Springer, Berlin, 1976.
- [3] O. V. Besov, V. P. Il'in and S. M. Nikol'skij, *Integral representations of functions and imbedding theorems*, Vol. I+II, V. H. Winston & Sons, Washington, D.C., 1978, 1979, Translated from Russian, Scripta Series in Mathematics, edited by M. H. Taibleson.
- [4] O. V. Besov, V. P. Il'in and S. M. Nikol'skij, *Integralnye predstavleniya funktsii i teoremy vlozheniya*, (Russian) Second ed., Fizmatlit "Nauka", Moscow, 1996.
- [5] V. I. Burenkov and E. D. Nursultanov, Description of interpolation spaces for local Morrey-type spaces, (Russian) *Tr. Mat. Inst. Steklova* **269** (2010), *Teoriya Funktsii i Differentsialnye Uravneniya*, 52-62; translation in *Proc. Steklov Inst. Math.* **269** (2010), 46-56.
- [6] Y. Cho and T. Ozawa, Sobolev inequalities with symmetry, *Comm. Contemp. Math.* **11** (2009), 355-365.
- [7] S. Coleman, V. Glazer and A. Martin, Action minima among solutions to a class of euclidean scalar field equations, *Comm. Math. Phys.* **58** (1978), 211-221.
- [8] G. Dafni and J. Xiao, Some new tent spaces and duality theorems for fractional Carleson measures and $Q_\alpha(\mathbb{R}^n)$, *J. Funct. Anal.* **208** (2004), 377-422.
- [9] A. El Baraka, An embedding theorem for Campanato spaces, *Electron. J. Differential Equations* **66** (2002), 1-17.
- [10] A. El Baraka, Function spaces of BMO and Campanato type, *Proc. of the 2002 Fez Conference on Partial Differential Equations*, 109-115 (electronic), *Electron. J. Differ. Equ. Conf.* **9**, Southwest Texas State Univ., San Marcos, TX, 2002.
- [11] A. El Baraka, Littlewood-Paley characterization for Campanato spaces, *J. Funct. Spaces Appl.* **4** (2006), 193-220.
- [12] J. Epperson and M. Frazier, An almost orthogonal radial wavelet expansion for radial distributions, *J. Fourier Anal. Appl.* **1** (1995), 311-353.
- [13] J. Epperson and M. Frazier, Polar wavelets and associated Littlewood-Paley theory, *Dissertationes Math.* **348** (1996), 51 pp.
- [14] M. Essén, S. Janson, L. Peng and J. Xiao, Q spaces of several real variables, *Indiana Univ. Math. J.* **49** (2000) 575-615.
- [15] M. Frazier and B. Jawerth, Decomposition of Besov spaces, *Indiana Univ. Math. J.* **34** (1985), 777-799.
- [16] M. Frazier and B. Jawerth, A discrete transform and decompositions of distribution spaces, *J. Funct. Anal.* **93** (1990), 34-170.
- [17] D. D. Haroske and L. Skrzypczak, Continuous embeddings of Besov-Morrey function spaces, *Acta Math. Sin. (Engl. Ser.)* **28** (2012), 1307-1328.
- [18] D. D. Haroske and L. Skrzypczak, *Embeddings of Besov-Morrey spaces on bounded domains*, Jena, Poznan, 2012.
- [19] H. Kozono and M. Yamazaki, Semilinear heat equations and the Navier-Stokes equation with distributions in new function spaces as initial data, *Comm. Partial Differential Equations* **19** (1994), 959-1014.
- [20] T. Kühn, H.-G. Leopold, W. Sickel and L. Skrzypczak, Entropy numbers of Sobolev embeddings of radial Besov spaces, *J. Approx. Theory* **121** (2003), 244-268.

- [21] I. Kuzin and S. Pohozaev, Entire Solutions of Semilinear Elliptic Equations, Birkhäuser Verlag, Basel, 1997.
- [22] Y. Liang, Y. Sawano, T. Ullrich, D. Yang and W. Yuan, New characterizations of Besov-Triebel-Lizorkin-Hausdorff spaces including coorbits and wavelets, *J. Fourier Anal. Appl.* **18** (2012), 1067-1111.
- [23] Y. Liang, Y. Sawano, T. Ullrich, D. Yang and W. Yuan, A new framework for generalized Besov-type and Triebel-Lizorkin-type spaces, *Dissertationes Math. (Rozprawy Mat.)* (to appear) or arXiv: 1205.2963.
- [24] P. L. Lions, Symétrie et compacité dans les espaces de Sobolev, *J. Funct. Anal.* **49** (1982), 315-334.
- [25] A. Mazzucato, Function space theory and applications to non-linear PDE, *Trans. Amer. Math. Soc.* **355** (2003), 1297-1369.
- [26] J. Peetre, *New Thoughts on Besov Spaces*, Duke Univ. Press, Durham, 1976.
- [27] Y. Sawano, Wavelet characterization of Besov-Morrey and Triebel-Lizorkin-Morrey spaces, *Funct. Approx. Comment. Math.* **38** (2008), 93-107.
- [28] Y. Sawano and H. Tanaka, Decompositions of Besov-Morrey spaces and Triebel-Lizorkin-Morrey spaces, *Math. Z.* **257** (2007), 871-904.
- [29] Y. Sawano, D. Yang and W. Yuan, New applications of Besov-type and Triebel-Lizorkin-type spaces, *J. Math. Anal. Appl.* **363** (2010), 73-85.
- [30] W. Sickel, Radial subspaces of Besov-Lizorkin-Triebel spaces, *Proceedings Nonlinear Analysis. Function Spaces and Applications 9* (ed. by J. Rakosnik), Inst. of Math., Academy of Sciences, Czech Rep., 2011, 169-215.
- [31] W. Sickel, Smoothness spaces related to Morrey spaces, Preprint, Jena, 2011.
- [32] W. Sickel and L. Skrzypczak, Radial subspaces of Besov and Lizorkin-Triebel classes: extended Strauss lemma and compactness of embeddings, *J. Fourier Anal. Appl.* **6** (2000), 639-662.
- [33] W. Sickel and L. Skrzypczak, On the interplay of regularity and decay in case of Radial functions II. homogeneous spaces, *J. Fourier Anal. Appl.* **18** (2012), 548-582.
- [34] W. Sickel and L. Skrzypczak, Subradial functions and compact embeddings, Preprint, Jena, Poznan, 2012.
- [35] W. Sickel, L. Skrzypczak and J. Vybiral, On the interplay of regularity and decay in case of Radial functions I. inhomogeneous spaces, *Commun. Contemp. Math.* **14** (2012), no. 1, 1250005, 60 pp.
- [36] L. Skrzypczak, Atomic decompositions on manifolds with bounded geometry, *Fourm Math.* **10** (1998), 19-38.
- [37] L. Skrzypczak, Rotation invariant subspaces of Besov and Triebel-Lizorkin space: compactness of embeddings, smoothness and decay of functions, *Rev. Mat. Iberoamericana* **18** (2002), 267-299.
- [38] W. A. Strauss, Existence of solitary waves in higher dimensions, *Comm. Math. Phys.* **55** (1977), 149-162.
- [39] L. Tang and J. Xu, Some properties of Morrey type Besov-Triebel spaces, *Math. Nachr.* **278** (2005), 904-914.
- [40] H. Triebel, *Theory of Function Spaces*, Birkhäuser Verlag, Basel, 1983.
- [41] H. Triebel, *Theory of Function Spaces II*, Birkhäuser Verlag, Basel, 1992.

- [42] H. Triebel, Theory of Function Spaces III, Birkhäuser Verlag, Basel, 2006.
- [43] H. Triebel, Local Function Spaces, Heat and Navier-Stokes Equations, EMS Publ. House, Zürich, 2013.
- [44] J. Xiao, Holomorphic Q Classes, Lecture Notes in Math., 1767, Springer, Berlin, 2001.
- [45] J. Xiao, Geometric Q_p Functions, Birkhäuser Verlag, Basel, 2006.
- [46] D. Yang and W. Yuan, A new class of function spaces connecting Triebel-Lizorkin spaces and Q spaces, J. Funct. Anal. **255** (2008), 2760-2809.
- [47] D. Yang and W. Yuan, New Besov-type spaces and Triebel-Lizorkin-type spaces including Q spaces, Math. Z. **265** (2010), 451-480.
- [48] D. Yang and W. Yuan, Characterizations of Besov-type and Triebel-Lizorkin-type spaces via maximal functions and local means, Nonlinear Anal. **73** (2010), 3805-3820.
- [49] D. Yang and W. Yuan, Relations among Besov-type spaces, Triebel-Lizorkin-type spaces and generalized Carleson measure spaces, Appl. Anal. (2011), Doi: 10.1080/00036811 (to appear).
- [50] W. Yuan, W. Sickel and D. Yang, Morrey and Campanato Meet Besov, Lizorkin and Triebel, Lecture Notes in Mathematics 2005, Springer-Verlag, Berlin, 2010, xi+281 pp.
- [51] W. Yuan, W. Sickel and D. Yang, Compact embeddings for radial and subradial subspaces of some Besov-type spaces related to Morrey spaces, Preprint, Beijing, Jena, 2012.

Wen Yuan

School of Mathematical Sciences, Beijing Normal University, Laboratory of Mathematics and Complex Systems, Ministry of Education, Beijing 100875, People's Republic of China

and

Mathematisches Institut, Friedrich-Schiller-Universität Jena, Ernst-Abbe-Platz 2, D-07743 Jena, Germany

E-mail: wenyuan@bnu.edu.cn

Winfried Sickel

Mathematisches Institut, Friedrich-Schiller-Universität Jena, Ernst-Abbe-Platz 2, D-07743 Jena, Germany

E-mail: winfried.sickel@uni-jena.de

Dachun Yang

School of Mathematical Sciences, Beijing Normal University, Laboratory of Mathematics and Complex Systems, Ministry of Education, Beijing 100875, People's Republic of China

E-mail: dcyang@bnu.edu.cn