

Solutions to the modified Korteweg-de Vries equation

Da-jun Zhang,* Song-lin Zhao, Ying-ying Sun, Jing Zhou

Department of Mathematics, Shanghai University, Shanghai 200444, P.R. China

June 9, 2018

Abstract

This is a continuation of Ref.[1](arXiv:nlin.SI/0603008). In the present paper we review solutions to the modified Korteweg-de Vries equation in terms of Wronskians. The Wronskian entry vector needs to satisfy a matrix differential equation set which contains complex operation. This is different from the case of the Korteweg-de Vries equation. We introduce an auxiliary matrix to deal with the complex operation and then we are able to give complete solution expressions for the matrix differential equation set. The obtained solutions to the modified Korteweg-de Vries equation can simply be categorized by two types: solitons and breathers, together with their limit cases. Besides, we give rational solutions to the modified Korteweg-de Vries equation in Wronskian form. This is derived with the help of the Galilean transformed modified Korteweg-de Vries equation. Finally, typical dynamics of the obtained solutions is analyzed and illustrated. We list out the obtained solutions and their corresponding basic Wronskian vectors in the conclusion part.

Keywords: The modified Korteweg-de Vries equation, Wronskian, breathers, rational solutions, dynamics

MSC 2010: 37K40, 35Q35, 35Q35

PACS: 02.30.Ik, 02.30.Jr, 05.45.Yv

Contents

1	Introduction	3
2	Wronskian solutions of the mKdV equation	4
2.1	Preliminary	4
2.2	CES of the mKdV equation	6
2.3	Simplification of the CES (2.12)	6
3	Solutions of the mKdV equation	7
3.1	Solitons	7
3.2	Breathers	12
4	Rational solutions	14
4.1	Backgrounds	14
4.2	Rational solutions	15

*Corresponding author. E-mail: djzhang@staff.shu.edu.cn

5	Dynamics analysis	17
5.1	Dynamics of solitons	17
5.2	Asymptotic behavior of limit solutions	20
5.3	Breathers	22
5.4	Dynamics of rational solutions	25
6	Conclusions	27
6.1	Summation	27
6.2	List of solutions	28
A	Proof of Theorem 1	30
B	Eigen-polynomial of $\mathbb{A} = \mathbb{B}\bar{\mathbb{B}}$	31
C	Discussions on the trivial solutions to the CES (2.18)	32
D	Proof for Theorem 2	33

1 Introduction

It is well known that the modified Korteweg-de Vries (mKdV) equation,

$$v_t + 6\varepsilon v^2 v_x + v_{xxx} = 0, \quad \varepsilon = \pm 1, \quad (1.1)$$

played an important role in constructing infinitely many conservation laws[2] and Lax pair for the Korteweg-de Vries (KdV) equation. The Lax pair led to the breakthrough of the Inverse Scattering Transform(IST)[3] and then the Soliton Theory. The mKdV equation is also famous for its special soliton behavior, breathers. Actually, the mKdV equation, or its Galilean transformed version,

$$V_t + 12\varepsilon v_0 V V_X + 6\varepsilon V^2 V_X + V_{XXX} = 0, \quad \varepsilon = \pm 1, \quad (1.2)$$

which is usually referred to as the mixed KdV-mKdV equation, arose in many physics contexts, such as anharmonic lattices[4], Alfvén waves[5], ion acoustic solitons[6, 7, 8], traffic jam[9, 10], Schottky barrier transmission lines[11], thin ocean jets[12, 13], internal waves[14, 15], heat pulses in solids[16], and so on.

With regard to exact solutions, many classical solving methods, such as Hirota's bilinear method[17], the IST[18, 19], commutation methods[20] and Wronskian technique[21, 22, 23] has been used to solve the mKdV equation. For more references on solutions of the mKdV equation, one can refer to Ref.[20] and the references therein.

In general, for a soliton equation with bilinear form, its solutions can be expressed through a Wronskian by imposing certain conditions on its Wronskian entry vector[24, 25, 26, 1]. For convenience in the following we refer to such conditions as condition equation set(CES). Usually for an (1+1)-dimensional soliton equation the crucial part in its CES is a coefficient matrix and the matrix and its any similar form leads to same solutions for the corresponding soliton equation. Thus it is possible to give a complete classification (or structure) for the solutions of the soliton equation by considering the canonical form of the coefficient matrix[26, 1]. It has been understood that the solutions generated from a Jordan form coefficient matrix are related to the solutions generated from a diagonal form coefficient matrix via some limiting procedure[1]. Therefore the latter solutions can be referred to as limit solutions. Actually, from the viewpoint of the IST, N solitons are identified by N distinct eigenvalues of the corresponding spectral problem, or in other words, N distinct simple poles $\{k_j\}$ of transparent coefficient $\frac{1}{a(k)}$. When $\{k_j\}$ are multiple-poles, the related multiple-pole solution can be obtained through a limiting procedure like $k_2 \rightarrow k_1$ from simple-pole solution. This limiting procedure is easily realized for solutions in Wronskian form[1]. Such a procedure is also helpful to understand the dynamics of limit solutions[27, 28, 29].

In Ref.[1] we mentioned four topics related to solutions in Wronskian form: to find the CES, to solve the CES, to describe relations between different kinds of solutions, and to discuss dynamics of the solutions. In the present paper, following this line, we will try to review the Wronskian solutions of the mKdV($\varepsilon = 1$) equation

$$v_t + 6v^2 v_x + v_{xxx} = 0, \quad (1.3)$$

together with its Galilean transformed version,

$$V_t + 12v_0 V V_X + 6V^2 V_X + V_{XXX} = 0. \quad (1.4)$$

The main results of the paper are the following.

- The CES for the mKdV equation can be given by

$$\varphi_x = \mathbb{B}\bar{\varphi}, \quad (1.5a)$$

$$\varphi_t = -4\varphi_{xxx}, \quad (1.5b)$$

where φ is the N -th order Wronskian entry vector, bar stands for complex conjugate and \mathbb{B} is a nontrivial $N \times N$ constant complex matrix. We note that there is a complex conjugate involved in the CES and this makes difficulties when solving the CES.

- There are only two kinds of solutions led by the CES (1.5): Solitons (together with their limit case) and breathers (together with their limit case). No rational solutions arise from (1.5) due to $|\mathbb{B}| \neq 0$.
- Rational solutions to the mKdV equation (1.3) can be derived by means of the KdV-mKdV equation (1.4).
- Dynamics of obtained solutions is analyzed and illustrated.

The paper is organized as follows. In Sec.2, we give a general CES of the mKdV equation and simplify the CES by introducing an auxiliary equation. Then in Sec.3 we solve the CES and classify the solutions as solitons and breathers. In Sec.4 we derive rational solutions to the mKdV equation. This is done with the help of the KdV-mKdV equation (1.4). Sec.5 consists of dynamic analysis and illustrations. Finally, in the conclusion section we list out the obtained solutions and their corresponding basic Wronskian vectors.

2 Wronskian solutions of the mKdV equation

2.1 Preliminary

An $N \times N$ Wronskian is defined as

$$W(\phi_1, \phi_2, \dots, \phi_N) = |\phi, \phi^{(1)}, \dots, \phi^{(N-1)}| = \begin{vmatrix} \phi_1^{(0)} & \phi_1^{(1)} & \dots & \phi_1^{(N-1)} \\ \phi_2^{(0)} & \phi_2^{(1)} & \dots & \phi_2^{(N-1)} \\ \vdots & \vdots & \ddots & \vdots \\ \phi_N^{(0)} & \phi_N^{(1)} & \dots & \phi_N^{(N-1)} \end{vmatrix}, \quad (2.1)$$

where $\phi_j^{(l)} = \partial^l \phi_j / \partial x^l$ and $\phi = (\phi_1, \phi_2, \dots, \phi_N)^T$ is called the entry vector of the Wronskian. Usually we use the compact form[24]

$$W(\phi) = |\phi, \phi^{(1)}, \dots, \phi^{(N-1)}| = |0, 1, \dots, N-1| = |\widehat{N-1}|, \quad (2.2)$$

where $\widehat{N-j}$ indicates the set of consecutive columns $0, 1, \dots, N-j$. In the paper we also employ the notation $\widetilde{N-j}$ to indicate the set of consecutive columns $1, 2, \dots, N-j$.

A Wronskian can provide simple forms for its derivatives and this advantage admits direct verification of solutions that are expressed in terms of Wronskians. The following matrix properties are usually necessary in Wronskian verification.

Proposition 1. [30, 1] Suppose that Ξ is an $N \times N$ matrix with column vector set $\{\Xi_j\}$; Ω is an $N \times N$ operator matrix with column vector set $\{\Omega_j\}$ and each entry $\Omega_{j,s}$ being an operator. Then we have

$$\sum_{j=1}^N |\Omega_j * \Xi| = \sum_{j=1}^N |(\Omega^T)_j * \Xi^T|, \quad (2.3)$$

where for any N -order column vectors A_j and B_j we define

$$A_j \circ B_j = (A_{1,j}B_{1,j}, A_{2,j}B_{2,j}, \dots, A_{N,j}B_{N,j})^T \quad (2.4)$$

and

$$|A_j * \Xi| = |\Xi_1, \dots, \Xi_{j-1}, A_j \circ \Xi_j, \Xi_{j+1}, \dots, \Xi_N|. \quad (2.5)$$

Proposition 2. [24] Suppose that D is an $N \times (N - 2)$ matrix and a, b, c, d are N th-order column vectors, then

$$|D, a, b||D, c, d| - |D, a, c||D, b, d| + |D, a, d||D, b, c| = 0. \quad (2.6)$$

Besides, to write solutions of CES in simple forms one may make use of lower triangular Toeplitz matrices. An N th-order lower triangular Toeplitz matrix means a matrix in the following form

$$\mathcal{A} = \begin{pmatrix} a_0 & 0 & 0 & \cdots & 0 & 0 \\ a_1 & a_0 & 0 & \cdots & 0 & 0 \\ a_2 & a_1 & a_0 & \cdots & 0 & 0 \\ \cdots & \cdots & \cdots & \cdots & \cdots & \cdots \\ a_{N-1} & a_{N-2} & a_{N-3} & \cdots & a_1 & a_0 \end{pmatrix}_{N \times N}, \quad a_j \in \mathbb{C}. \quad (2.7)$$

All such matrices form a commutative semigroup $\tilde{G}_N(\mathbb{C})$ with identity with respect to matrix multiplication and inverse, and the set $G_N(\mathbb{C}) = \{\mathcal{A} | \mathcal{A} \in \tilde{G}_N(\mathbb{C}), |\mathcal{A}| \neq 0\}$ makes an Abelian group. Besides (2.7), we will also need the following block lower triangular Toeplitz matrix,

$$\mathcal{A}^B = \begin{pmatrix} A_0 & 0 & 0 & \cdots & 0 & 0 \\ A_1 & A_0 & 0 & \cdots & 0 & 0 \\ A_2 & A_1 & A_0 & \cdots & 0 & 0 \\ \cdots & \cdots & \cdots & \cdots & \cdots & \cdots \\ A_{N-1} & A_{N-2} & A_{N-3} & \cdots & A_1 & A_0 \end{pmatrix}_{2N \times 2N}, \quad (2.8)$$

where $A_j = \begin{pmatrix} a_{j1} & 0 \\ 0 & a_{j2} \end{pmatrix}$ and $\{a_{js}\}$ are arbitrary complex numbers. All such block matrices also compose a commutative semigroup with identity which we denote by $\tilde{G}_{2N}^B(\mathbb{C})$, and the set $G_{2N}^B(\mathbb{C}) = \{\mathcal{A}^B | \mathcal{A}^B \in \tilde{G}_{2N}^B(\mathbb{C}), |\mathcal{A}^B| \neq 0\}$ makes an Abelian group, too. If all the elements are real, then we correspondingly denote the above mentioned matrix sets by $\tilde{G}_N(\mathbb{R})$, $G_N(\mathbb{R})$, $\tilde{G}_{2N}^B(\mathbb{R})$ and $G_{2N}^B(\mathbb{R})$. For more properties of such matrices please refer to Ref.[1].

2.2 CES of the mKdV equation

By the transformation

$$v = i \left(\ln \frac{\bar{f}}{f} \right)_x = i \frac{\bar{f}_x f - \bar{f} f_x}{\bar{f} f}, \quad (2.9)$$

the mKdV equation (1.3) can be bilinearized as[17]

$$(D_t + D_x^3) \bar{f} \cdot f = 0, \quad (2.10a)$$

$$D_x^2 \bar{f} \cdot f = 0, \quad (2.10b)$$

where i is the imaginary unit, \bar{f} is the complex conjugate of f , and D is the well-known Hirota's bilinear operator defined by[31, 32]

$$D_t^m D_x^n a(t, x) \cdot b(t, x) = \frac{\partial^m}{\partial s^m} \frac{\partial^n}{\partial y^n} a(t + s, x + y) b(t - s, x - y) |_{s=0, y=0}, \quad m, n = 0, 1, \dots$$

The bilinear mKdV equation (2.10) admits a solution f in Wronskian form.

Theorem 1. *A Wronskian solution to the bilinear mKdV equation (2.10) is given as*

$$f = W(\phi) = |\widehat{N-1}|, \quad (2.11)$$

provided that its entry vector ϕ satisfies

$$\phi_x = B(t) \bar{\phi}, \quad (2.12a)$$

$$\phi_t = -4\phi_{xxx} + C(t)\phi, \quad (2.12b)$$

where $B(t) = (B_{ij}(t))_{N \times N}$ and $C(t) = (C_{ij}(t))_{N \times N}$ are two $N \times N$ matrices of t but independent of x , and satisfy

$$|\bar{B}(t)|_t = 0, \quad \text{tr}(C(t)) \in \mathbb{R}(t), \quad (2.13a)$$

$$B_t(t) + B(t)\bar{C}(t) = C(t)B(t). \quad (2.13b)$$

The proof is given in A.

2.3 Simplification of the CES (2.12)

To solve the CES (2.12) with arbitrary $B(t)$ and $C(t)$ which satisfy (2.13) we first introduce a non-singular $N \times N$ complex matrix $H(t) \in \mathbb{C}_{N \times N}(t)$ such that ([33], also see [1])

$$H_t(t) = -H(t)C(t). \quad (2.14)$$

By $H(t)$ we then introduce a new Wronskian entry vector

$$\psi = H(t)\phi, \quad (2.15)$$

which transfers the CES (2.12) to the following,

$$\psi_x = \tilde{B}\bar{\psi}, \quad (2.16a)$$

$$\psi_t = -4\psi_{xxx}, \quad (2.16b)$$

where $\tilde{B} = H(t)B(t)\bar{H}^{-1}(t)$ has to be a constant matrix independent of both x and t due to the compatibility condition (2.13b) (noting that now $C(t) = 0$).

We note that the Wronskians composed by ϕ and ψ , which we respectively denote by $f(\phi)$ and $f(\psi)$, yield same solutions to the mKdV equation through the transformation (2.9) due to $f(\psi) = |H(t)|f(\phi)$. That means in the following one only needs to focus on the CES (2.16). However, since there exists a complex operation in (2.16), solutions can not be classified in terms of the canonical form of \tilde{B} , as done in [26, 1]. To overcome the difficulty we introduce an auxiliary equation

$$\psi_{xx} = \tilde{A}\psi, \quad (2.17)$$

where $\tilde{A} = \tilde{B}\tilde{\bar{B}}$. Our plan now is to first solve the equation set composed by (2.17) and (2.16b), which is nothing but the CES of the KdV equation and have been well studied in Refs.[26] and [1]. Then in the second step we impose condition (2.16a) on the obtained solution ψ and finally get solutions for (2.16).

In addition, noting that \tilde{A} and its any similar form $\mathbb{A} = P^{-1}\tilde{A}P$ always generates same solutions to the mKdV equation, in the following let us focus on the CES

$$\varphi_{xx} = \mathbb{A}\varphi, \quad (2.18a)$$

$$\varphi_x = \mathbb{B}\bar{\varphi}, \quad (2.18b)$$

$$\varphi_t = -4\varphi_{xxx}, \quad (2.18c)$$

where $\varphi = P^{-1}\psi$, $\mathbb{B} = P^{-1}\tilde{B}\bar{P}$ and

$$\mathbb{A} = \mathbb{B}\bar{\mathbb{B}}. \quad (2.19)$$

In the next section we will see that solutions to the mKdV equation can be classified in terms of the canonical form of \mathbb{A} (rather than the canonical form of \mathbb{B}).

3 Solutions of the mKdV equation

In this section, we list several possible choices of \mathbb{A} and derive the related Wronskian entry vectors, one of which is for breathers. We will also discuss the limiting relationship of some solutions.

First, for the matrix \mathbb{A} defined by (2.19), we have the following result on its eigenvalues.

Proposition 3. *The eigenvalues of \mathbb{A} defined by (2.19) are either real or, if there are some complex ones, appear as conjugate pairs.*

We leave the proof in B.

According to the eigenvalues of \mathbb{A} , we can categorize solutions to the mKdV equation as solitons and breathers, which correspond to real eigenvalues and complex eigenvalues of conjugate pairs, respectively.

3.1 Solitons

Case I. Solitons: When \mathbb{A} has N distinct real positive eigenvalues $\{\lambda_j^2\}$ its canonical form reads

$$\mathbb{A} = \text{Diag}(\lambda_1^2, \lambda_2^2, \dots, \lambda_N^2), \quad (3.1)$$

where, for convenient to discuss, we let $\lambda_j = \varepsilon_j \|k_j\| \neq 0$, in which $\varepsilon_j = \pm 1$ and k_j can either real or complex numbers with distinct absolute values. We consider two subcases.

(1). $k_j \in \mathbb{R}$, i.e.

$$\mathbb{A} = \text{Diag}(k_1^2, k_2^2, \dots, k_N^2). \quad (3.2)$$

Following the relation (2.19), we can take

$$\mathbb{B} = \text{Diag}(\pm k_1, \pm k_2, \dots, \pm k_N). \quad (3.3)$$

We neglect the sign \pm because this can be compensated by the arbitrariness of k_j . So next we take

$$\mathbb{B} = \text{Diag}(k_1, k_2, \dots, k_N), \quad k_j \in \mathbb{R}. \quad (3.4)$$

For the above matrix \mathbb{B} , the solution to the CES (2.18) can be

$$\varphi = (\varphi_1, \varphi_2, \dots, \varphi_N)^T, \quad (3.5a)$$

where

$$\varphi_j = a_j^+ e^{\xi_j} + i a_j^- e^{-\xi_j}, \quad \xi_j = k_j x - 4k_j^3 t + \xi_j^{(0)}, \quad a_j^+, a_j^-, k_j, \xi_j^{(0)} \in \mathbb{R}. \quad (3.5b)$$

When $a_j^+ = (-1)^{j-1}$, $a_j^- = 1$, (3.5b) reads

$$\varphi_j = (-1)^{j-1} e^{\xi_j} + i e^{-\xi_j}. \quad (3.6)$$

In this case, the corresponding Wronskian solution (2.9) with $f(\varphi)$ can be written as[34]

$$f = \left(\prod_{j=1}^N e^{\xi_j} \right) \left(\prod_{1 \leq j < l \leq N} (k_j - k_l) \right) \sum_{\mu=0,1} \exp \left\{ \sum_{j=1}^N \mu_j (2\eta_j + \frac{\pi}{2} i) + \sum_{1 \leq j < l \leq N} \mu_j \mu_l A_{jl} \right\},$$

where the sum over $\mu = 0, 1$ refers to each of $\mu_j = 0, 1$ for $j = 1, 2, \dots, N$, and

$$\eta_j = -\xi_j - \frac{1}{4} \sum_{l=2, l \neq j}^N A_{jl}, \quad e^{A_{jl}} = \left(\frac{k_l - k_j}{k_l + k_j} \right)^2.$$

This coincides with the N -soliton solution in Hirota's exponential polynomial form[37].

(2). $k_j = k_{j1} + i k_{j2} \in \mathbb{C}$, i.e.

$$\mathbb{A} = \text{Diag}(\lambda_1^2, \lambda_2^2, \dots, \lambda_N^2), \quad \lambda_j^2 = k_{j1}^2 + k_{j2}^2. \quad (3.7)$$

In this case we have

$$\mathbb{B} = \text{Diag}(k_1, k_2, \dots, k_N), \quad k_j \in \mathbb{C}, \quad (3.8)$$

and the solution to the CES (2.18) can be given by (3.5a) with

$$\varphi_j = \gamma_j (a_j^+ e^{\xi_j} + i a_j^- e^{-\xi_j}), \quad \xi_j = \lambda_j x - 4\lambda_j^3 t + \xi_j^{(0)}, \quad a_j^+, a_j^-, \xi_j^{(0)} \in \mathbb{R}, \quad (3.9a)$$

where

$$\gamma_j = 1 + \frac{i(\lambda_j - k_{j1})}{k_{j2}}, \quad \lambda_j = \varepsilon_j \|k_j\|. \quad (3.9b)$$

Now, if we compare (3.5b) and (3.9a), we can find that both of them provide same solution to the mKdV equation through the transformation (2.9). In particular, when $k_{j1} = 0$, i.e.,

$$\mathbb{B} = \text{Diag}(ik_{12}, ik_{22}, \dots, ik_{N2}), \quad (3.10)$$

and we take $\lambda_j = k_{j2}$, the entry function (3.9a) reduces to

$$\varphi_j = (1+i)(a_j^+ e^{\xi_j} + ia_j^- e^{-\xi_j}), \quad \xi_j = k_j x - 4k_j^3 t + \xi_j^{(0)}, \quad a_j^+, a_j^-, \xi_j^{(0)} \in \mathbb{R}. \quad (3.11)$$

This was first given by Nimmo and Freeman[22] as Wronskian entries for soliton solutions.

Let us remark this case as follows.

Remarks:

- When \mathbb{B} in the CES (2.18b) and (2.18c) is a diagonal matrix (3.8) of which the diagonal elements have different absolute values, no matter these diagonal elements are real or complex, the related Wronskian $f(\varphi)$ generates N -soliton solutions to the mKdV equation.
- Besides, we specify the non-degenerate condition*

$$\|k_i\| \neq \|k_j\|, \quad (i \neq j), \quad (3.12)$$

i.e., k_i and k_j ($i \neq j$) can not appear on the same circle with the original point as the center of the circle. Otherwise, the solution degenerates.

Case II. Limit solutions of solitons: Corresponding to Case I, we discuss two subcases.

(1). Let

$$\mathbb{A} = \begin{pmatrix} k_1^2 & 0 & 0 & \dots & 0 & 0 & 0 \\ 2k_1 & k_1^2 & 0 & \dots & 0 & 0 & 0 \\ 1 & 2k_1 & k_1^2 & \dots & 0 & 0 & 0 \\ \dots & \dots & \dots & \dots & \dots & \dots & \dots \\ 0 & 0 & 0 & \dots & 1 & 2k_1 & k_1^2 \end{pmatrix}_N, \quad k_1 \in \mathbb{R}. \quad (3.13)$$

In this subcase, general solution to the equation set (2.18a) and (2.18c) is[1]

$$\hat{\phi} = \mathcal{A} \mathcal{Q}_0^+ + \mathcal{B} \mathcal{Q}_0^-, \quad \mathcal{A}, \mathcal{B} \in \tilde{G}_N(\mathbb{C}), \quad (3.14)$$

where

$$\mathcal{Q}_0^\pm = (\mathcal{Q}_{0,0}^\pm, \mathcal{Q}_{0,1}^\pm, \dots, \mathcal{Q}_{0,N-1}^\pm)^T, \quad \mathcal{Q}_{0,s}^\pm = \frac{1}{s!} \partial_{k_1}^s e^{\pm \xi_1}, \quad (3.15)$$

ξ_1 is defined in (3.5b), $\tilde{G}_N(\mathbb{C})$ is the commutative set of all the N th-order lower triangular Toeplitz matrices, see Sec.2.1.

*The above non-degenerate relation can also be described as follows. Define the equivalent relation \sim on the complex plane \mathbb{C} :

$$k_i \sim k_j \quad \text{iff} \quad \|k_i\| = \|k_j\|.$$

The quotient space \mathbb{C}/\sim denotes the positive half real axis. Then to get a non-degenerate soliton solution one needs $k_i \not\sim k_j$, ($i \neq j$).

For the matrix \mathbb{B} satisfying (2.19) we take

$$\mathbb{B} = \begin{pmatrix} k_1 & 0 & 0 & \cdots & 0 & 0 \\ 1 & k_1 & 0 & \cdots & 0 & 0 \\ \cdots & \cdots & \cdots & \cdots & \cdots & \cdots \\ 0 & 0 & 0 & \cdots & 1 & k_1 \end{pmatrix}_N. \quad (3.16)$$

Then, substituting into (2.18b) yields

$$\mathcal{A}\mathcal{Q}_{0,x}^+ + \mathcal{B}\mathcal{Q}_{0,x}^- = \mathbb{B}(\bar{\mathcal{A}}\mathcal{Q}_0^+ + \bar{\mathcal{B}}\mathcal{Q}_0^-). \quad (3.17)$$

Meanwhile, it can be verified that

$$\mathcal{Q}_{0,x}^+ = \mathbb{B}\mathcal{Q}_0^+, \quad \mathcal{Q}_{0,x}^- = -\mathbb{B}\mathcal{Q}_0^-. \quad (3.18)$$

Noting that $\mathbb{B} \in \tilde{G}_N(\mathbb{R})$, substituting (3.18) into (3.17), and making use of the commutative property of $\tilde{G}_N(\mathbb{C})$, we have

$$\mathbb{B}(\mathcal{A}\mathcal{Q}_0^+ - \mathcal{B}\mathcal{Q}_0^-) = \mathbb{B}(\bar{\mathcal{A}}\mathcal{Q}_0^+ + \bar{\mathcal{B}}\mathcal{Q}_0^-). \quad (3.19)$$

Then, compared with (3.17) we immediately get

$$\mathcal{A} = \bar{\mathcal{A}}, \quad \mathcal{B} = -\bar{\mathcal{B}}, \quad (3.20)$$

which means \mathcal{A} is real and \mathcal{B} pure imaginary. In the end, the solution to the CES (2.18) can be described as

$$\varphi = \mathcal{A}^+\mathcal{Q}_0^+ + i\mathcal{A}^-\mathcal{Q}_0^-, \quad \mathcal{A}^\pm \in \tilde{G}_N(\mathbb{R}). \quad (3.21)$$

We note that solutions generated from (3.21) can also be derived from the solution given in Case I.(1) by a limiting procedure(cf.[1]). Let us explain this procedure by starting from the following Wronskian

$$f(\varphi) = \frac{W(\varphi_1, \varphi_2, \cdots, \varphi_N)}{\prod_{j=2}^N (k_j - k_1)^{j-1}} \quad (3.22)$$

with $\varphi_1 = \varphi_1(k_1, x, t) = a_1^+ e^{\xi_1} + i a_1^- e^{-\xi_1}$ as defined in (3.5b) and $\varphi_j = \varphi_1(k_j, x, t)$. (3.22) gives a Wronskian solution to the bilinear mKdV equation (2.10). Taking the limit $k_j \rightarrow k_1$ successively for $j = 2, 3, \cdots, N$ and using L'Hospital rule, the Wronskian (3.22) goes to a Wronskian $W(\varphi)$ with entry vector (3.21), where the arbitrary coefficient matrices \mathcal{A}, \mathcal{B} can come from a_1^\pm by considering a_1^\pm to be some polynomials of k_1 (cf.[1]).

(2). Corresponding to Case I.(2), let us consider

$$\mathbb{A} = \begin{pmatrix} k_{11}^2 + k_{12}^2 & 0 & 0 & \cdots & 0 & 0 & 0 \\ 2k_{12} & k_{11}^2 + k_{12}^2 & 0 & \cdots & 0 & 0 & 0 \\ 1 & 2k_{12} & k_{11}^2 + k_{12}^2 & \cdots & 0 & 0 & 0 \\ \cdots & \cdots & \cdots & \cdots & \cdots & \cdots & \cdots \\ 0 & 0 & 0 & \cdots & 1 & 2k_{12} & k_{11}^2 + k_{12}^2 \end{pmatrix}_N, \quad (3.23)$$

where $k_{11}, k_{12} \in \mathbb{R}$ and $k_{12} \neq 0$. It then follows from (2.19) that one can take

$$\mathbb{B} = \begin{pmatrix} -ik_1 & 0 & 0 & \cdots & 0 & 0 \\ 1 & -ik_1 & 0 & \cdots & 0 & 0 \\ \cdots & \cdots & \cdots & \cdots & \cdots & \cdots \\ 0 & 0 & 0 & \cdots & 1 & -ik_1 \end{pmatrix}_N, \quad k_1 = k_{11} + ik_{12}. \quad (3.24)$$

For the matrix \mathbb{A} defined by (3.23), the general solution to the equation set (2.18a) and (2.18c) can be written as

$$\varphi = \mathcal{A}\mathcal{P}_0^+ + \mathcal{B}\mathcal{P}_0^-, \quad \mathcal{A}, \mathcal{B} \in \tilde{G}_N(\mathbb{C}), \quad (3.25)$$

where[†]

$$\mathcal{P}_0^\pm = (\mathcal{P}_{0,0}^\pm, \mathcal{P}_{0,1}^\pm, \dots, \mathcal{P}_{0,N-1}^\pm)^T, \quad \mathcal{P}_{0,s}^\pm = \frac{1}{s!} \partial_{k_{12}}^s e^{\pm \xi_1}, \quad (3.26a)$$

$$\xi_1 = \lambda_1 x - 4\lambda_1^3 t + \xi_1^{(0)}, \quad \lambda_1 = \sqrt{k_{11}^2 + k_{12}^2}. \quad (3.26b)$$

Next, we substitute (3.25) together with (3.26) into (2.18b) so that we identify \mathcal{A}, \mathcal{B} for (2.18b). This substitution yields

$$\mathcal{A}\mathcal{P}_{0,x}^+ + \mathcal{B}\mathcal{P}_{0,x}^- = \mathbb{B}(\bar{\mathcal{A}}\mathcal{P}_0^+ + \bar{\mathcal{B}}\mathcal{P}_0^-) = \bar{\mathcal{A}}\mathbb{B}\mathcal{P}_0^+ + \bar{\mathcal{B}}\mathbb{B}\mathcal{P}_0^-, \quad (3.27)$$

where we have made use of the commutative property of $\tilde{G}_N(\mathbb{C})$. Then, noting that

$$\mathcal{P}_{0,x}^+ = W\mathcal{P}_0^+, \quad \mathcal{P}_{0,x}^- = -W\mathcal{P}_0^-, \quad (3.28)$$

where

$$W = \begin{pmatrix} w_0 & 0 & 0 & \cdots & 0 & 0 \\ w_1 & w_0 & 0 & \cdots & 0 & 0 \\ w_2 & w_1 & w_0 & \cdots & 0 & 0 \\ \cdots & \cdots & \cdots & \cdots & \cdots & \cdots \\ w_{N-1} & w_{N-2} & w_{N-3} & \cdots & w_1 & w_0 \end{pmatrix}_N, \quad w_j = \frac{1}{j!} \partial_{k_{12}}^j \lambda_1, \quad (3.29)$$

and substituting (3.28) into (3.27), we get the relation

$$\mathcal{A}W = \bar{\mathcal{A}}\mathbb{B}, \quad -\mathcal{B}W = \bar{\mathcal{B}}\mathbb{B}. \quad (3.30)$$

To have a clearer result, we write

$$\mathcal{A} = \mathcal{A}_1 + i\mathcal{A}_2, \quad \mathcal{B} = \mathcal{B}_1 + i\mathcal{B}_2, \quad \mathbb{B} = \mathbb{B}_1 + i\mathbb{B}_2, \quad (3.31)$$

where $\mathcal{A}_1, \mathcal{A}_2, \mathcal{B}_1, \mathcal{B}_2$ are in $\tilde{G}_N(\mathbb{R})$ and

$$\mathbb{B}_1 = \begin{pmatrix} k_{12} & & & & 0 \\ 1 & k_{12} & & & \\ & \ddots & \ddots & & \\ 0 & & 1 & k_{12} & \end{pmatrix}, \quad \mathbb{B}_2 = \begin{pmatrix} -k_{11} & & & & 0 \\ 0 & -k_{11} & & & \\ & \ddots & \ddots & & \\ 0 & & 0 & -k_{11} & \end{pmatrix}. \quad (3.32)$$

[†]Here we define $\mathcal{P}_{0,s}^\pm$ by taking derivative with respect to k_{12} rather than k_{11} because in this case we always have $k_{12} \neq 0$.

Then (3.30) yields

$$\mathcal{A}_1(W - \mathbb{B}_1) - \mathcal{A}_2\mathbb{B}_2 = 0, \quad \mathcal{A}_1\mathbb{B}_2 - \mathcal{A}_2(\mathbb{B}_1 + W) = 0, \quad (3.33)$$

$$\mathcal{B}_1(W + \mathbb{B}_1) + \mathcal{B}_2\mathbb{B}_2 = 0, \quad \mathcal{B}_1\mathbb{B}_2 - \mathcal{B}_2(\mathbb{B}_1 - W) = 0, \quad (3.34)$$

which provides the equation sets for $\mathcal{A}_1, \mathcal{A}_2, \mathcal{B}_1, \mathcal{B}_2$. We note that since all the elements in (3.33) and (3.34) are in $\tilde{G}_N(\mathbb{R})$, we can treat (3.33) and (3.34) as ordinary linear equation sets. Let us look at (3.33). It first indicates

$$\mathcal{A}_2 = \mathbb{B}_2^{-1}(W - \mathbb{B}_1)\mathcal{A}_1, \quad (3.35)$$

and further, by eliminating \mathcal{A}_2 ,

$$(\mathbb{B}_1^2 + \mathbb{B}_2^2 - W^2)\mathcal{A}_1 = 0. \quad (3.36)$$

We note that

$$\mathbb{B}_1^2 + \mathbb{B}_2^2 - W^2 = 0. \quad (3.37)$$

In fact, by calculation we find

$$(W^2)_{i,j} = \begin{cases} 0, & i < j, \\ \frac{1}{(i-j)!} \partial_{k_{12}}^{i-j} (k_{11}^2 + k_{12}^2), & i \geq j, \end{cases}$$

from which it is easy to verify (3.37). Thus, it turns out that \mathcal{A}_1 can be an arbitrary element in $\tilde{G}_N(\mathbb{R})$ and then

$$\mathcal{A} = \mathcal{A}_1\mathcal{M}, \quad \mathcal{M} = I_N + i\mathbb{B}_2^{-1}(W - \mathbb{B}_1), \quad (3.38)$$

where I_N is the N th-order unit matrix. Similarly, we can find

$$\mathcal{B} = i\mathcal{B}_2\mathcal{M}, \quad \mathcal{B}_2 \in \tilde{G}_N(\mathbb{R}).$$

Thus we can conclude that the solution to the CES (2.12) can be given by

$$\varphi = \mathcal{M}(\mathcal{A}^+\mathcal{P}_0^+ + i\mathcal{A}^-\mathcal{P}_0^-), \quad \mathcal{A}^\pm \in \tilde{G}_N(\mathbb{R}), \quad (3.39)$$

where \mathcal{M} is defined in (3.38). Obviously, the matrix \mathcal{M} contributes nothing through the transformation (2.9) to the mKdV equation. Therefore in practice we may remove \mathcal{M} and use the effective part

$$\varphi = \mathcal{A}^+\mathcal{P}_0^+ + i\mathcal{A}^-\mathcal{P}_0^-, \quad \mathcal{A}^\pm \in \tilde{G}_N(\mathbb{R}), \quad (3.40)$$

which is as same as (3.21).

3.2 Breathers

Case III. Breathers: When \mathbb{A} has distinct complex (conjugate-pair) eigenvalues, we may have breather solutions. Let us consider a $2N$ -th order matrix,

$$\mathbb{A} = \text{Diag}(k_1^2, \bar{k}_1^2, \dots, k_N^2, \bar{k}_N^2)_{2N}, \quad k_j \neq 0, \quad (3.41)$$

where $k_j \in \mathbb{C}$, $j = 1, 2, \dots, N$. The matrix \mathbb{B} which generates breathers is

$$\mathbb{B} = \text{Diag}(\Theta_1, \Theta_2, \dots, \Theta_N)_{2N}, \quad \Theta_j = \begin{pmatrix} 0 & k_j \\ \bar{k}_j & 0 \end{pmatrix}. \quad (3.42)$$

For this case, the Wronskian entry vector, i.e., the solution to the CES (2.18), can be taken as

$$\varphi = (\varphi_{11}, \varphi_{12}, \varphi_{21}, \varphi_{22}, \dots, \varphi_{N1}, \varphi_{N2})^T, \quad (3.43a)$$

where

$$\begin{aligned} \varphi_{j1} &= a_j e^{\xi_j} + b_j e^{-\xi_j}, \quad \varphi_{j2} = \bar{a}_j e^{\bar{\xi}_j} - \bar{b}_j e^{-\bar{\xi}_j}, \\ \xi_j &= k_j x - 4k_j^3 t + \xi_j^{(0)}, \quad a_j, b_j, \xi_j^{(0)} \in \mathbb{C}. \end{aligned} \quad (3.43b)$$

With the above φ as basic entry vector, the Wronskian $f(\varphi)$ will provide breather solutions for the mKdV equation. For non-trivial solutions we need $k_{j1} \neq 0$, (see Sec.5.3).

Case IV. Limit solutions of breathers: In this case let us consider the following block matrix,

$$\mathbb{A} = \begin{pmatrix} \mathcal{K} & 0 & 0 & \dots & 0 & 0 & 0 \\ \tilde{\mathcal{K}} & \mathcal{K} & 0 & \dots & 0 & 0 & 0 \\ I_2 & \tilde{\mathcal{K}} & \mathcal{K} & \dots & 0 & 0 & 0 \\ \dots & \dots & \dots & \dots & \dots & \dots & \dots \\ 0 & 0 & 0 & \dots & I_2 & \tilde{\mathcal{K}} & \mathcal{K} \end{pmatrix}_{2N}, \quad (3.44a)$$

where

$$\mathcal{K} = \begin{pmatrix} k_1^2 & 0 \\ 0 & \bar{k}_1^2 \end{pmatrix}, \quad \tilde{\mathcal{K}} = \begin{pmatrix} 2k_1 & 0 \\ 0 & 2\bar{k}_1 \end{pmatrix}, \quad I_2 = \begin{pmatrix} 1 & 0 \\ 0 & 1 \end{pmatrix}. \quad (3.44b)$$

The matrix \mathbb{B} satisfying (2.19) can be taken as

$$\mathbb{B} = \begin{pmatrix} \tilde{B} & 0 & \dots & 0 & 0 \\ \tilde{I}_2 & \tilde{B} & \dots & 0 & 0 \\ \dots & \dots & \dots & \dots & \dots \\ 0 & 0 & \dots & \tilde{I}_2 & \tilde{B} \end{pmatrix}_{2N}, \quad (3.45a)$$

where

$$\tilde{I}_2 = \begin{pmatrix} 0 & 1 \\ 1 & 0 \end{pmatrix}, \quad \tilde{B} = \begin{pmatrix} 0 & k_1 \\ \bar{k}_1 & 0 \end{pmatrix}. \quad (3.45b)$$

The Wronskian vector of this case is also in the form of

$$\varphi = (\varphi_{1,1}, \varphi_{1,2}, \varphi_{2,1}, \varphi_{2,2}, \dots, \varphi_{N,1}, \varphi_{N,2})^T, \quad (3.46a)$$

and for convenience we set

$$\varphi^+ = (\varphi_{1,1}, \varphi_{2,1}, \dots, \varphi_{N,1})^T, \quad \varphi^- = (\varphi_{1,2}, \varphi_{2,2}, \dots, \varphi_{N,2})^T. \quad (3.46b)$$

Substituting (3.46) into (2.18) with the above \mathbb{A} and \mathbb{B} we get

$$\varphi_{xx}^+ = \mathbb{A}_N \varphi^+, \quad \varphi_{xx}^- = \bar{\mathbb{A}}_N \varphi^-, \quad (3.47a)$$

$$\varphi_x^+ = \mathbb{B}_N \bar{\varphi}^-, \quad \varphi_x^- = \bar{\mathbb{B}}_N \bar{\varphi}^+, \quad (3.47b)$$

$$\varphi_t^\pm = -4\varphi_{xxx}^\pm, \quad (3.47c)$$

where

$$\mathbb{A}_N = \begin{pmatrix} k_1^2 & 0 & 0 & \cdots & 0 & 0 & 0 \\ 2k_1 & k_1^2 & 0 & \cdots & 0 & 0 & 0 \\ 1 & 2k_1 & k_1^2 & \cdots & 0 & 0 & 0 \\ \cdots & \cdots & \cdots & \cdots & \cdots & \cdots & \cdots \\ 0 & 0 & 0 & \cdots & 1 & 2k_1 & k_1^2 \end{pmatrix}_N, \quad (3.48a)$$

$$\mathbb{B}_N = \begin{pmatrix} k_1 & 0 & 0 & \cdots & 0 & 0 \\ 1 & k_1 & 0 & \cdots & 0 & 0 \\ \cdots & \cdots & \cdots & \cdots & \cdots & \cdots \\ 0 & 0 & 0 & \cdots & 1 & k_1 \end{pmatrix}_N. \quad (3.48b)$$

From (3.47a), (3.47c) and (3.48a), one first has

$$\varphi^+ = \mathcal{A}Q_0^+ + \mathcal{B}Q_0^-, \quad \varphi^- = \mathcal{C}\bar{Q}_0^+ + \mathcal{D}\bar{Q}_0^-, \quad \mathcal{A}, \mathcal{B}, \mathcal{C}, \mathcal{D} \in \tilde{G}_N(\mathbb{C}), \quad (3.49)$$

where Q_0^\pm are defined by (3.15) together with ξ_1 defined in (3.43b). Then substituting (3.49) into (3.47b) and making using of (3.18), one finds

$$\mathcal{C} = \bar{\mathcal{A}}, \quad \mathcal{D} = -\bar{\mathcal{B}}. \quad (3.50)$$

Thus, (3.49) reads

$$\varphi^+ = \mathcal{A}Q_0^+ + \mathcal{B}Q_0^-, \quad \varphi^- = \bar{\mathcal{A}}\bar{Q}_0^+ - \bar{\mathcal{B}}\bar{Q}_0^-, \quad \mathcal{A}, \mathcal{B} \in \tilde{G}_N(\mathbb{C}). \quad (3.51)$$

The Wronskian $f(\varphi)$ with φ defined by (3.46) with (3.51) will provide a limit solution of breathers for the mKdV equation. In fact, quite similar to the procedure for the limit solutions of solitons we described in Sec.3.1, here the Wronskian $f(\varphi)$ with (3.46) is related to the N -breather solution by taking the limit $k_j \rightarrow k_1$ successively for $j = 2, 3, \dots, N$.

4 Rational solutions

4.1 Backgrounds

Following solution structures of the KdV equation[1], rational solutions should be led from zero eigenvalues of the coefficient matrix \mathbb{A} . For the mKdV equation this requires $|\mathbb{B}| = 0$. However, this is not allowed in the Wronskian verification (see Appendix C.4) because a trivial \mathbb{B} will lead to a zero Wronskian in the light of (A.1). Thus, it is clear that to get non-trivial rational solutions to the mKdV equation, we need a non-trivial matrix \mathbb{B} .

Let us go back to the KdV-mKdV equation (1.4), i.e.,

$$V_t + 12v_0VV_X + 6V^2V_X + V_{XXX} = 0, \quad (4.1)$$

which is related to the mKdV equation (1.3) through a Galilean transformation

$$v(x, t) = v_0 + V(X, t), \quad x = X + 6v_0^2t, \quad (4.2)$$

where v_0 is a real parameter. We note that the equation (4.1) admits non-trivial and non-singular rational solutions when $v_0 \neq 0$. Then using the transformation (4.2) rational solutions to the mKdV equation can be obtained. This fact has been realized via Bäcklund transformation(BT)[35] and Hirota method with a limiting procedure[36, 37], but the presentation for high order rational solutions is complicated. In the following we will derive rational solutions in terms of Wronskian, which provides not only explicit but also impact forms for high order rational solutions.

4.2 Rational solutions

Still employing the same transformation as (2.9), i.e.,

$$V = i \left(\ln \frac{\bar{f}}{f} \right)_X, \quad (4.3)$$

the KdV-mKdV equation (4.1) can be written into the bilinear form[38, 39]

$$(D_t + D_X^3) \bar{f} \cdot f = 0, \quad (4.4a)$$

$$(D_X^2 - 2iv_0 D_X) \bar{f} \cdot f = 0. \quad (4.4b)$$

For the solutions to (4.4) in Wronskian form, we have

Theorem 2. *The bilinear equation (4.4) admits Wronskian solution*

$$f = W(\phi) = |\widehat{N - 1}|, \quad (4.5)$$

where the entry vector ϕ satisfies

$$i\phi_X = v_0\phi + B(t)\bar{\phi}, \quad (4.6a)$$

$$\phi_t = -4\phi_{XXX} + C(t)\phi, \quad (4.6b)$$

in which $B(t)$ and $C(t)$ are two $N \times N$ matrices of t but independent of x , and satisfy

$$|B(t)| \neq 0, \quad (4.7a)$$

$$\text{tr}(C(t)) \in \mathbb{R}(t), \quad (4.7b)$$

$$B_t(t) + B(t)\bar{C}(t) - C(t)B(t) = 0. \quad (4.7c)$$

The proof is similar to the one for Theorem 1, but (4.6a) results in complicated expression for \bar{f} and its derivatives. We leave the proof in D.

As in Sec.2.3, with the help of the auxiliary matrix \mathbb{A} and auxiliary equation

$$\varphi_{XX} = \mathbb{A}\varphi, \quad (4.8)$$

one can simplify the CES (4.6) to

$$i\varphi_X = v_0\varphi + \mathbb{B}\bar{\varphi}, \quad (4.9a)$$

$$\varphi_t = -4\varphi_{XXX}, \quad (4.9b)$$

where both \mathbb{A} and \mathbb{B} are $N \times N$ complex constant matrices and related by

$$\mathbb{A} = \mathbb{B}\bar{\mathbb{B}} - v_0^2 I_N, \quad (4.10)$$

in which I_N is the N th-order unit matrix. It might be possible that here we discuss all possible solutions according to the eigenvalues of \mathbb{A} , as we have done in the previous section. However, since we have had a clear description for solitons and breathers of the mKdV equation in the previous section, and the parameter v_0 will bring more complexity, in the following we can

neglect the discussion of \mathbb{A} and let us only focus on rational solutions. In fact, rational solutions correspond to the zero eigenvalues of \mathbb{A} .

We derive rational solutions as the limit solutions of solitons. The N -soliton solution corresponds to

$$\mathbb{B} = \text{diag}\left(-\sqrt{v_0^2 + k_1^2}, -\sqrt{v_0^2 + k_2^2}, \dots, -\sqrt{v_0^2 + k_N^2}\right), \quad (4.11)$$

where we take k_j to be N distinct real positive numbers. In this case, a solution to the CES (4.9) is

$$\varphi = (\varphi_1, \varphi_2, \dots, \varphi_N)^T, \quad (4.12)$$

with

$$\varphi_j = \sqrt{2v_0 + 2ik_j} e^{\eta_j} + \sqrt{2v_0 - 2ik_j} e^{-\eta_j}, \quad \eta_j = k_j X - 4k_j^3 t, \quad (4.13)$$

This provides an N -soliton solution to the KdV-mKdV equation (4.1) through the transformation (4.3) with $f(\phi)$.

Now in the CES (4.9a) we take \mathbb{B} to be a lower triangular Toeplitz matrix,

$$\mathbb{B} = \begin{pmatrix} \alpha_0 & & & & \\ \alpha_1 & \alpha_0 & & & \\ \vdots & \ddots & \ddots & & \\ \alpha_{N-1} & \cdots & \alpha_1 & \alpha_0 & \end{pmatrix}, \quad (4.14)$$

with

$$\alpha_j = -\frac{1}{(2j)!} \frac{\partial^{2j}}{\partial k_1^{2j}} \sqrt{v_0^2 + k_1^2} \Big|_{k_1=0}, \quad (j = 0, 1, \dots, N-1). \quad (4.15)$$

In this case the CES (4.9) admits a solution

$$\psi = (\psi_1, \psi_2, \dots, \psi_N)^T, \quad (4.16a)$$

with

$$\psi_{j+1} = \frac{1}{(2j)!} \frac{\partial^{2j}}{\partial k_1^{2j}} \varphi_1 \Big|_{k_1=0}, \quad (j = 0, 1, \dots, N-1), \quad (4.16b)$$

where φ_1 is defined by (4.13). Then, with such a ψ as basic column vector, the Wronskian

$$f = W(\psi) = |\widehat{N-1}| \quad (4.17)$$

provides non-singular rational solutions to the KdV-mKdV equation (4.1). A simplified form of these solutions is

$$V(X, t) = \frac{-2(F_{1,X}F_2 - F_1F_{2,X})}{F_1^2 + F_2^2}, \quad F_1 = \text{Re}[f], \quad F_2 = \text{Im}[f]. \quad (4.18)$$

We list the first three non-trivial f (for $N = 2, 3, 4$, respectively) in the following,

$$f = 4(2v_0X + i), \quad (4.19a)$$

$$f = \frac{16v_0\sqrt{2v_0}}{3} \left[X^3 + 12t - \frac{3X}{4v_0^2} + \frac{3i}{2v_0} \left(X^2 + \frac{1}{4v_0^2} \right) \right], \quad (4.19b)$$

$$\begin{aligned} f = & -\frac{1}{v_0^4} - \frac{4X^2}{v_0^2} - \frac{16}{3}(12tX + X^4) - \frac{64}{45}v_0^2(720t^2 - 60tX^3 - X^6) \\ & + 4iv_0 \left(-\frac{24t}{v_0^2} + \frac{X}{v_0^4} + 32tX^2 + \frac{16}{15}X^5 \right). \end{aligned} \quad (4.19c)$$

For the rational solutions to the mKdV equation (1.3), we have

Proposition 4. *The non-trivial rational solutions to the mKdV equation is given by*

$$v(x, t) = v_0 - \frac{2(F_{1,X}F_2 - F_1F_{2,X})}{F_1^2 + F_2^2}, \quad X = x - 6v_0^2t, \quad (4.20)$$

where f is the Wronskian (4.17) composed with (4.16), $F_1 = \text{Re}[f]$, $F_2 = \text{Im}[f]$.

The first non-trivial rational solution to the mKdV equation reads

$$v = v_0 - \frac{4v_0}{4v_0^2X^2 + 1}, \quad X = x - 6v_0^2t, \quad (4.21)$$

and the second one

$$v = v_0 - \frac{12v_0(X^4 + \frac{3}{2v_0^2}X^2 - \frac{3}{16v_0^4} - 24Xt)}{4v_0^2(X^3 + 12t - \frac{3X}{4v_0^2})^2 + 9(X^2 + \frac{1}{4v_0^2})^2}, \quad X = x - 6v_0^2t. \quad (4.22)$$

We note that there is a bilinear BT[22] related to (4.4) and the BT admits multi-soliton solutions[22] and rational solutions[40] in Wronskian form. Besides, rational solutions of the mKdV equation (for both $\varepsilon = \pm 1$) may also be derived (through the Galilean transformed version) by using the long-wave-limit approach described in Ref.[41] (also see [23, 42]).

In next section we will discuss dynamics of solutions including these rational solutions.

5 Dynamics analysis

In this section we investigate dynamics of two-soliton solutions, limit solutions, breathers and rational solutions. To describe the relationship between two-soliton solution and the simplest limit solution, let us start from the asymptotic behaviors of two-soliton interactions.

5.1 Dynamics of solitons

Soliton solutions to the mKdV equation (1.3) can be described by

$$v(x, t) = -\frac{2(F_{1,x}F_2 - F_1F_{2,x})}{F_1^2 + F_2^2}, \quad F_1 = \text{Re}[f], \quad F_2 = \text{Im}[f], \quad (5.1)$$

where $f = f(\varphi) = |\widehat{N-1}|$ is the Wronskian composed by the basic column vector φ which is defined by (3.5), or equivalently, by either (3.9a) or (3.11) in Case I. We note that from the transformation (2.9) the solution to the mKdV equation (1.3) can also be written as

$$v = -2\left(\arctan \frac{F_1}{F_2}\right)_x = 2\left(\arctan \frac{F_2}{F_1}\right)_x, \quad F_1 = \text{Re}[f], \quad F_2 = \text{Im}[f], \quad (5.2)$$

while (5.1) gives a more explicit form.

In the following we investigate 1- and 2-soliton solutions, which are, respectively, corresponding to

$$f = f_1 = f(\varphi_1) = \varphi_1, \quad (5.3a)$$

$$f = f_2 = f((\varphi_1, \varphi_2)^T) = \begin{vmatrix} \varphi_1 & \varphi_{1,x} \\ \varphi_2 & \varphi_{2,x} \end{vmatrix}, \quad (5.3b)$$

with φ_j defined by (3.5b), i.e.,

$$\varphi_j = a_j^+ e^{\xi_j} + i a_j^- e^{-\xi_j}, \quad \xi_j = k_j x - 4k_j^3 t + \xi_j^{(0)}, \quad a_j^\pm, k_j, \xi_j^{(0)} \in \mathbb{R}. \quad (5.4)$$

Then, one-soliton solution to the mKdV equation (1.3) reads

$$v = -2 \cdot \operatorname{sgn} \left[\frac{a_1^-}{a_1^+} \right] \cdot k_1 \cdot \operatorname{sech} \left(2k_1 x - 8k_1^3 t - \ln \left| \frac{a_1^-}{a_1^+} \right| \right), \quad (5.5)$$

as depicted in Fig.1, where for convenience, we call (a) soliton and (b) anti-soliton due to the signs of their amplitudes.

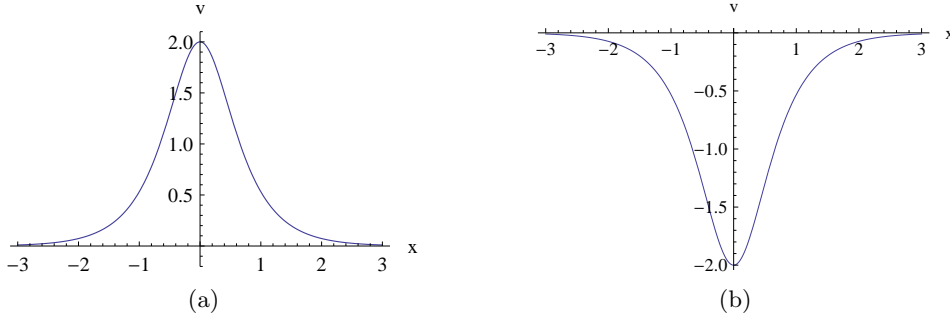

Figure 1: The shape of one-soliton solution given by (5.5) at $t = 0$. (a). Soliton for $a_1^+ = a_1^- = 1$, $k_1 = -1$ and $\xi_1^{(0)} = 0$. (b). Anti-soliton for $a_1^+ = a_1^- = 1$, $k_1 = 1$ and $\xi_1^{(0)} = 0$.

Obviously, this soliton is identified by the amplitude

$$\text{Amp} = -2 \cdot \operatorname{sgn} \left[\frac{a_1^-}{a_1^+} \right] \cdot k_1$$

and top trace (trajectory)

$$x(t) = 4k_1^2 t + \frac{1}{2k_1} \ln \left| \frac{a_1^-}{a_1^+} \right|, \quad (5.6)$$

or velocity $4k_1^2$. Obviously, solitons of the mKdV equation are single-direction waves.

Next, let us look at two-soliton solution. The two-soliton solution of the mKdV (1.3) can be expressed by (5.1) where from (5.3b)

$$F_1 = (k_2 - k_1) (a_1^- a_2^- e^{4(k_1^3 + k_2^3)t - (k_1 + k_2)x} + a_1^+ a_2^+ e^{-4(k_1^3 + k_2^3)t + (k_1 + k_2)x}), \quad (5.7a)$$

$$F_2 = (k_2 + k_1) (a_1^- a_2^+ e^{4(k_1^3 - k_2^3)t - (k_1 - k_2)x} - a_1^+ a_2^- e^{4(-k_1^3 + k_2^3)t + (k_1 - k_2)x}). \quad (5.7b)$$

We assume that $a_j^\pm \neq 0$ and set $\operatorname{sgn} \left[\frac{a_1^-}{a_1^+} \right] = \operatorname{sgn} \left[\frac{a_2^-}{a_2^+} \right]$, so that F_1, F_2 are not zero at same time. Without loss of generality, we also take $0 < |k_2| < |k_1|$. For the analysis of asymptotic behaviors, it is convenient to use the following expression

$$v = 2 \left(\arctan \frac{F_2}{F_1} \right)_x. \quad (5.8)$$

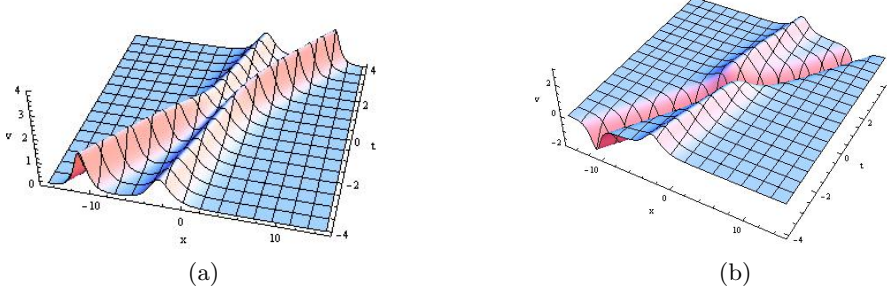

Figure 2: Two-soliton interactions. (a). Soliton-soliton for $a_1^+ = a_1^- = a_2 = 1$, $b_2 = -1$, $k_1 = 0.8$, $k_2 = 0.5$ and $\xi_1^{(0)} = \xi_2^{(0)} = 0$. (b). Soliton-anti-soliton for $a_1^+ = a_1^- = a_2 = 1$, $b_2 = -1$, $k_1 = -0.8$, $k_2 = 0.5$ and $\xi_1^{(0)} = \xi_2^{(0)} = 0$.

There are two types of 2-soliton interactions, soliton-soliton (or anti-soliton-anti-soliton) interaction and soliton-anti-soliton interaction, as shown in Fig.2.

To investigate asymptotic behaviors of the two solitons involved in interaction, we first name them k_1 -soliton and k_2 -soliton, respectively. Then we rewrite the two-soliton solution (5.8) in terms of the following coordinates,

$$(X_1 = x - 4k_1^2 t, t), \quad (5.9)$$

which then gives

$$v = 2 \left(\arctan \frac{(a_1^+ a_2^- e^{2k_1 X_1} - a_2^+ a_1^- e^{8k_2(k_1^2 - k_2^2)t + 2k_2 X_1})(k_1 + k_2)}{(a_1^- a_2^- + a_1^+ a_2^+ e^{8k_2(k_1^2 - k_2^2)t + 2(k_1 + k_2)X_1})(k_1 - k_2)} \right)_{X_1}. \quad (5.10)$$

Noting that for any $0 < |k_2| < |k_1|$ it is always valid that $k_1^2 - k_2^2 > 0$ and $\frac{k_1 + k_2}{k_1 - k_2} > 0$, we can keep X_1 to be constant and let t go to infinity. Then we can find there is only k_1 -soliton left along the line $X_1 = \text{const.}$ and also find how the k_1 -soliton is asymptotically identified by its top trace and amplitude, for both $t \rightarrow \pm\infty$.

As for details, when $k_2 > 0$, $t \rightarrow -\infty$ or $k_2 < 0$, $t \rightarrow +\infty$, i.e. $\text{sgn}[k_2] \cdot t \rightarrow -\infty$, the solution (5.10) becomes

$$\begin{aligned} v &= 2 \left(\arctan \frac{a_1^+(k_1 + k_2)e^{2k_1 X_1}}{a_1^-(k_1 - k_2)} \right)_{X_1} \\ &= 2 \cdot \text{sgn} \left[\frac{a_1^-}{a_1^+} \right] \cdot k_1 \cdot \text{sech} \left(2k_1 X_1 - \ln \left| \frac{a_1^-}{a_1^+} \right| + \ln \frac{k_1 + k_2}{k_1 - k_2} \right); \end{aligned} \quad (5.11)$$

and when $k_2 > 0$, $t \rightarrow +\infty$ or $k_2 < 0$, $t \rightarrow -\infty$, i.e. $\text{sgn}[k_2] \cdot t \rightarrow +\infty$, (5.10) becomes

$$\begin{aligned} v &= 2 \left(\arctan \frac{-a_1^-(k_1 + k_2)}{a_1^+ e^{2k_1 X_1} (k_1 - k_2)} \right)_{X_1} \\ &= 2 \cdot \text{sgn} \left[\frac{a_1^-}{a_1^+} \right] \cdot k_1 \cdot \text{sech} \left(2k_1 X_1 - \ln \left| \frac{a_1^-}{a_1^+} \right| - \ln \frac{k_1 + k_2}{k_1 - k_2} \right). \end{aligned} \quad (5.12)$$

We can also rewrite the two-soliton solution (5.8) in terms of the coordinates

$$(X_2 = x - 4k_2^2 t, t), \quad (5.13)$$

and do a similar asymptotic analysis for the k_2 -soliton. Finally, we reach to

Theorem 3. *Suppose that $\text{sgn}\left[\frac{a_1^-}{a_1^+}\right] = \text{sgn}\left[\frac{a_2^-}{a_2^+}\right]$, $a_j^\pm \neq 0$ and $0 < |k_2| < |k_1|$ in (5.10). Then, when $\text{sgn}[k_2] \cdot t \rightarrow \pm\infty$, the k_1 -soliton asymptotically follows*

$$\text{top trace : } x(t) = 4k_1^2 t + \frac{1}{2k_1} \ln \left| \frac{a_1^-}{a_1^+} \right| \pm \frac{1}{2k_1} \ln \frac{k_1 + k_2}{k_1 - k_2}, \quad (5.14a)$$

$$\text{amplitude : } 2 \cdot \text{sgn}\left[\frac{a_1^-}{a_1^+}\right] \cdot k_1, \quad (5.14b)$$

and when $\text{sgn}[k_1] \cdot t \rightarrow \pm\infty$, the k_2 -soliton asymptotically follows

$$\text{top trace : } x(t) = 4k_2^2 t + \frac{1}{2k_2} \ln \left| \frac{a_2^-}{a_2^+} \right| \pm \frac{1}{2k_2} \ln \frac{k_1 + k_2}{k_1 - k_2}, \quad (5.15a)$$

$$\text{amplitude : } -2 \cdot \text{sgn}\left[\frac{a_2^-}{a_2^+}\right] \cdot k_2. \quad (5.15b)$$

The phase shift for the k_j -soliton after interactions is $\frac{1}{k_j} \ln \frac{k_2 + k_1}{k_1 - k_2}$.

Now it is completely clear how the two-soliton interactions are related to the parameters $\{k_j, a_j, b_j\}$. This will be helpful to understand the asymptotic behavior of limit solutions.

5.2 Asymptotic behavior of limit solutions

The simplest limit solution in Case II is

$$v = 2 \left(\arctan \frac{a_1^+ a_1^- (-48k_1^3 t + 4k_1 x)}{a_1^{-2} e^{8k_1^3 t - 2k_1 x} + a_1^{+2} e^{-8k_1^3 t + 2k_1 x}} \right)_x. \quad (5.16)$$

This is derived from (5.2) with

$$f = \begin{vmatrix} \varphi_1 & \varphi_{1,x} \\ \partial_{k_1} \varphi_1 & (\partial_{k_1} \varphi_1)_x \end{vmatrix}, \quad (5.17a)$$

where φ_1 is defined in (3.5b), i.e.,

$$\varphi_1 = a_1^+ e^{\xi_1} + i a_1^- e^{-\xi_1}, \quad \xi_1 = k_1 x - 4k_1^3 t + \xi_1^{(0)}, \quad a_1^\pm, k_1, \xi_1^{(0)} \in \mathbb{R}. \quad (5.17b)$$

The solution (5.16) is depicted in Fig.3. We characterize dynamics of the solution by the following two points, which are typically different from the interaction of two normal solitons that we described in the previous subsection. These two points are

- Soliton-anti-soliton interaction with (asymptotically) asymmetric wave shape,
- Top trace of each soliton is asymptotically governed by logarithm and linear functions.

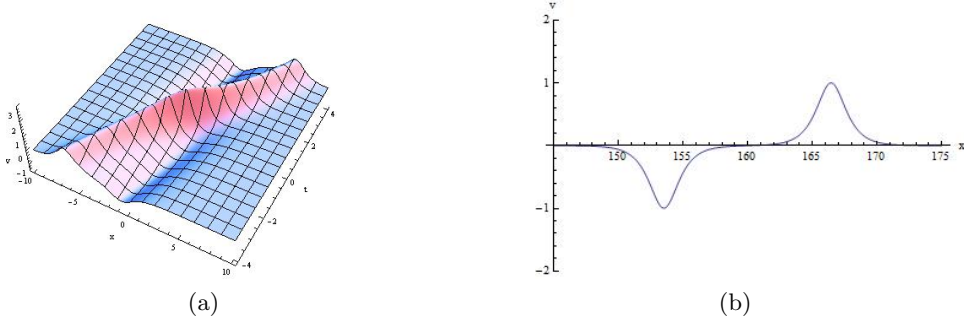

Figure 3: Limit solution given by (5.16) for $a_1^+ = a_1^- = 1$, $k_1 = 0.5$ and $\xi_1^{(0)} = 0$. (a). Shape and motion. (b). Asymmetric wave shape at $t = 160$.

The first point can be explained as follows. Recall the two-soliton interaction with $a_2^\pm = a_1^\pm \neq 0$ and $k_1 \cdot k_2 > 0$. According to Theorem 3, this is a soliton-anti-soliton interaction and the absolute of amplitude of each soliton is $2|k_j|$. Obviously, the asymmetric shape of limit solution (5.16) coincides well with the limit $k_2 \rightarrow k_1$.

To understand the second point, again we put the limit solution in the coordinate system

$$(Y = x - 4k_1^2 t, t), \quad (5.18)$$

and this gives

$$v = 2 \left(\arctan \frac{4a_1^+ a_1^- e^{2k_1 Y} k_1 (Y - 8k_1^2 t)}{a_1^{-2} + a_1^{+2} e^{4k_1 Y}} \right)_Y, \quad (5.19)$$

which is described in Fig.4.

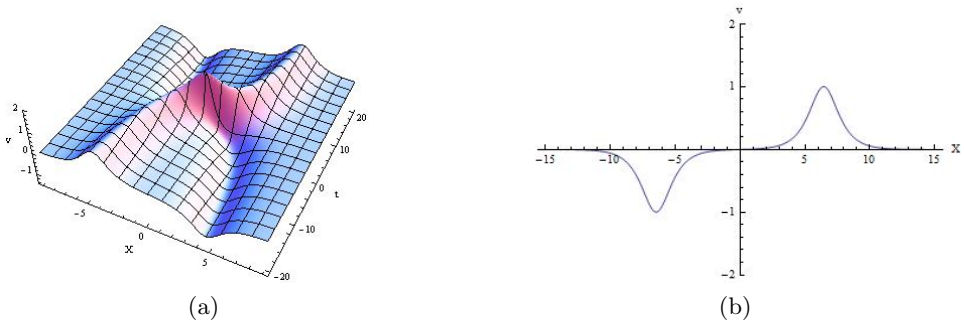

Figure 4: Limit solution given by (5.19) for $a_1^+ = a_1^- = 1$ and $k_1 = 0.5$. (a). Shape and motion. (b). Asymmetric wave shape at $t = 160$.

For convenience here we suppose that $k_1 > 0$. Then by analyzing the leading terms as $t \rightarrow \pm\infty$ in the numerator and denominator in (5.19), we can conclude the asymptotic behaviors of the limit solution (5.19) as follows.

Theorem 4. Suppose that $a_1^\pm \neq 0$ and $k_1 > 0$ in (5.19). When $t \rightarrow -\infty$ there are two waves moving with amplitudes $\mp 2 \cdot \operatorname{sgn}\left[\frac{a_1^-}{a_1^+}\right] \cdot k_1$ and top traces governed by the logarithm functions

$$Y_\pm = \frac{1}{2k_1} \left(\ln \left| \frac{a_1^-}{a_1^+} \right| \pm \ln(-32k_1^3 t) \right), \quad (5.20a)$$

where the subscript \pm of Y stands for $Y \rightarrow \pm\infty$. When $t \rightarrow +\infty$, there are also two waves moving with amplitudes $\pm 2 \cdot \operatorname{sgn}\left[\frac{a_1^-}{a_1^+}\right] \cdot k_1$ and top traces

$$Y_\pm = \frac{1}{2k_1} \left(\ln \left| \frac{a_1^-}{a_1^+} \right| \pm \ln(32k_1^3 t) \right). \quad (5.20b)$$

Replacing Y by x by using (5.18) the top traces of the waves in Fig.3 are then asymptotically governed by linear and logarithm functions of t .

Let us end up this subsection with the following remark. With regard to the limit solutions the top traces (or waves trajectories) are governed by (linear and) logarithm functions should be a typical characteristic, which differs from normal soliton interactions with straight line trajectories. (See [30, 27, 28, 29] for more examples).

5.3 Breathers

Wronskian entries in Case III provides breather solutions to the mKdV equation (1.3). The simplest one corresponds to

$$f = \begin{vmatrix} \varphi_{11} & \varphi_{11,x} \\ \varphi_{12} & \varphi_{12,x} \end{vmatrix} = F_1 + iF_2, \quad (5.21a)$$

where

$$\varphi_{11} = a_1 e^{\xi_1} + b_1 e^{-\xi_1}, \quad \varphi_{12} = \bar{a}_1 e^{\bar{\xi}_1} - \bar{b}_1 e^{-\bar{\xi}_1}, \quad (5.21b)$$

$$\xi_1 = k_1 x - 4k_1^3 t, \quad k_1, a_1, b_1 \in \mathbb{C}, \quad (5.21c)$$

$$F_1 = 4k_{11}(a_{11}b_{11} + a_{12}b_{12}) \cos(24k_{11}^2 k_{12} t - 8k_{12}^3 t - 2k_{12} x) \\ + 4k_{11}(a_{12}b_{11} - a_{11}b_{12}) \sin(24k_{11}^2 k_{12} t - 8k_{12}^3 t - 2k_{12} x), \quad (5.21d)$$

$$F_2 = -2k_{12} e^{-2k_{11}(4k_{11}^2 t + 12k_{12}^2 t + x)} [(b_{11}^2 + b_{12}^2) e^{16k_{11}^3 t} \\ + (a_{11}^2 + a_{12}^2) e^{4k_{11}(12k_{12}^2 t + x)}], \quad (5.21e)$$

and we have written

$$k_1 = k_{11} + ik_{12}, \quad a_1 = a_{11} + ia_{12}, \quad b_1 = b_{11} + ib_{12}.$$

Then the breather solution is expressed by (5.1) with the above F_1, F_2 . We further assume that

$$\sin \theta = \frac{a_{11}b_{11} + a_{12}b_{12}}{\alpha}, \quad \alpha = \sqrt{(a_{11}b_{11} + a_{12}b_{12})^2 + (a_{12}b_{11} - a_{11}b_{12})^2},$$

and then rewrite (5.1) as[‡]

$$v = -2 \left(\arctan \frac{P}{Q} \right)_x, \quad (5.22a)$$

where

$$P = 2k_{11}\alpha \sin [2k_{12}(x - 4t(3k_{11}^2 - k_{12}^2)) - \theta], \quad (5.22b)$$

$$Q = k_{12}[(a_{11}^2 + a_{12}^2)e^{2k_{11}(x+4t(3k_{12}^2-k_{11}^2))} + (b_{11}^2 + b_{12}^2)e^{-2k_{11}(x+4t(3k_{12}^2-k_{11}^2))}]. \quad (5.22c)$$

Such a breather is described in Fig.5.

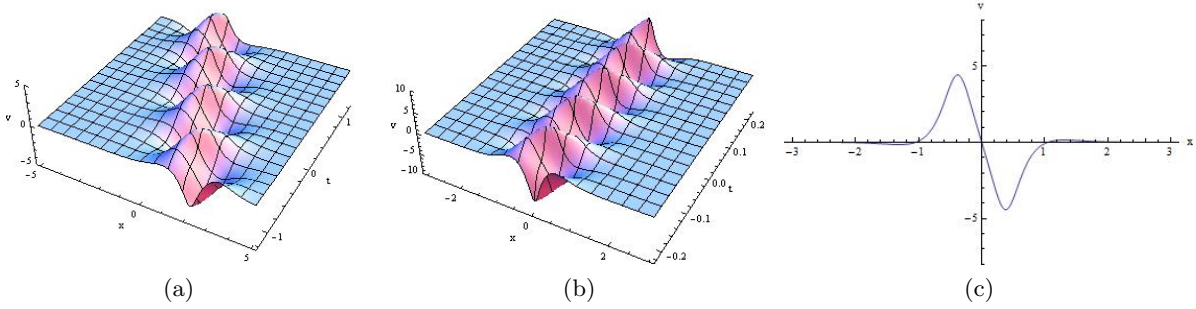

Figure 5: Breathers given by (5.22). (a). A moving breather with $a_1 = 1 + i$, $b_1 = 2 + 0.5i$, $k_1 = 0.8 - 0.6i$. (b). A stationary breather with $a_1 = b_1 = 1$, $k_1 = \sqrt{3} + i$. (c). A 2D-plot of (b) at $t = 0$.

Fig.5(a) shows an oscillating wave moving along a straight line. The oscillation comes from the sine function and the frequency depends on both x and t . To understand more on the wave we use the coordinates

$$(Z = x + 4t(3k_{12}^2 - k_{11}^2), t) \quad (5.23)$$

to rewrite the solution (5.22) as

$$v = -2 \left(\arctan \frac{2k_{11}\alpha \sin (2k_{12}(Z - 8t(k_{11}^2 + k_{12}^2)) - \theta)}{k_{12}((a_{11}^2 + a_{12}^2)e^{2k_{11}Z} + (b_{11}^2 + b_{12}^2)e^{-2k_{11}Z})} \right)_Z, \quad (5.24)$$

and then fix $Z = 0$, i.e., looking at the wave along the straight line $Z = 0$. Then it is clear that

- The breather travels along the straight line $Z = 0$, in other words, the wave speed is $4(3k_{12}^2 - k_{11}^2)$, which means it admits bi-direction traveling.
- A stationary breather appears when $3k_{12}^2 = k_{11}^2$, as depicted in Fig.5(b).
- Under the coordinate system (5.23) the frequency only depends on t and the period reads

$$T = \frac{\pi}{8k_{12}(k_{11}^2 + k_{12}^2)}. \quad (5.25)$$

[‡]From (5.22) we can see that $k_{1j} \neq 0$ is necessary for getting nontrivial breather solutions.

We note that in two dimensions (fixing t) the breather is in fact a spindle-shape wave. Let us go back to the solution (5.22). If we fix time t , then the breather oscillates with frequency $\frac{|k_{12}|}{\pi}$ and its amplitude decays by the rate $e^{-2|xk_{11}|}$ as $x \rightarrow \pm\infty$. That means if $|k_{12}|$ is small and $|k_{11}|$ is relatively large so that the amplitude decay becomes the dominating factor, we get a ‘normal’ breather as shown in Fig.6(a); while if $|k_{11}|$ is small enough and $|k_{12}| \gg |k_{11}|$ so that the oscillation dominates, we will see a spindle-like wave shown in Fig.6(b). In the latter case, the wave will travel with high speed and high oscillating frequency. This can lead to overlaps of ‘normal’ oscillating waves (like Fig.6(a)) during their traveling, which makes a spindle shape.

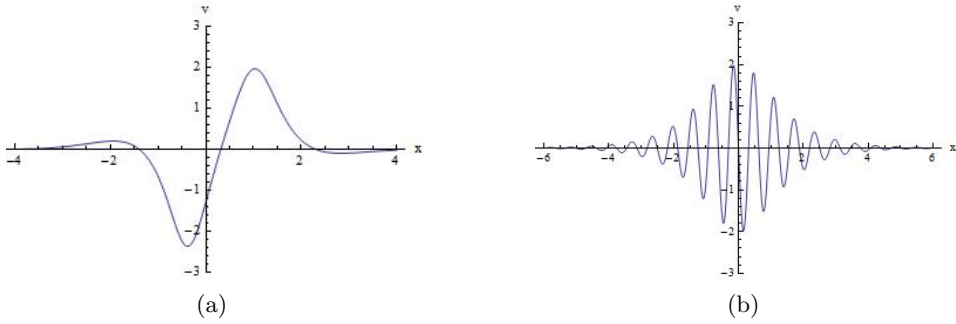

Figure 6: Shape of breathers given by (5.22). (a). ‘Normal’ shape at $t = 0$ with $a_1 = 1 + i$, $b_1 = 2 + 0.5i$, $k_1 = 0.8 - 0.6i$. (b). Spindle-shape breather at $t = 0$ with $a_1 = 1 + i$, $b_1 = 1 + i$, $k_1 = 0.5 + 5i$.

Finally, in this subsection we list and depict two-breather solution and the simplest limit breather solution, without further asymptotic analysis. Both solutions can be given by (5.1) with f being a 4 by 4 Wronskian

$$f = |\varphi, \varphi_x, \varphi_{xx}, \varphi_{xxx}|, \quad (5.26)$$

where for the 2-breather solution

$$\varphi = (\varphi_{11}, \varphi_{12}, \varphi_{21}, \varphi_{22})^T, \quad (5.27a)$$

$$\varphi_{j1} = a_j e^{\xi_j} + b_j e^{-\xi_j}, \quad \varphi_{j2} = \bar{a}_j e^{\bar{\xi}_j} - \bar{b}_j e^{-\bar{\xi}_j}, \quad \xi_j = k_j x - 4k_j^3 t + \xi_j^{(0)}, \quad (5.27b)$$

in which $a_j, b_j, k_j, \xi_j^{(0)} \in \mathbb{C}$, and for the limit breather

$$\varphi = (\varphi_{11}, \varphi_{12}, \partial_{k_1} \varphi_{11}, \partial_{\bar{k}_1} \varphi_{12})^T, \quad (5.28)$$

in which $\varphi_{11}, \varphi_{12}$ are defined by (5.27b).

Fig.7 shows the two-breather interaction where from the density plot (b) one can clearly see that the two breathers are traveling along straight lines and a phase shift appears after interaction. Fig.8 shows the shape and motion of a limit breather solution, where from the density plot (b) one can clearly see that the breather trajectories are not any longer straight lines, Here we conjecture that they are governed by logarithm functions.

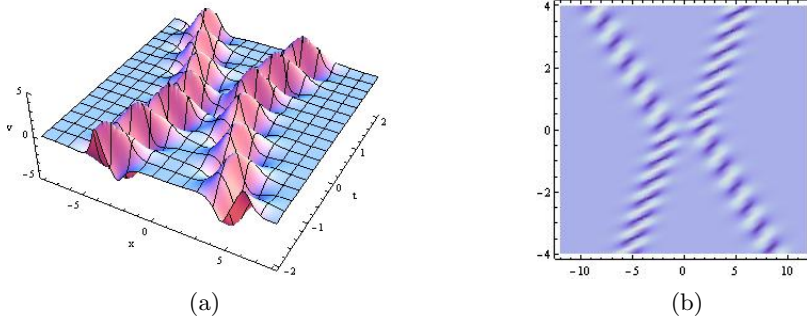

Figure 7: Shape and motion of two breather solution given by (5.1) with (5.26) and (5.27). (a). 3D-plot for $a_1 = b_1 = a_2 = b_2 = 1$, $k_1 = 1 + 0.5i$, $k_2 = 0.8 - 0.6i$ and $\xi_1^{(0)} = \xi_2^{(0)} = 0$. (b). Density plot of (a) for $x \in [-12, 12]$, $t \in [-4, 4]$.

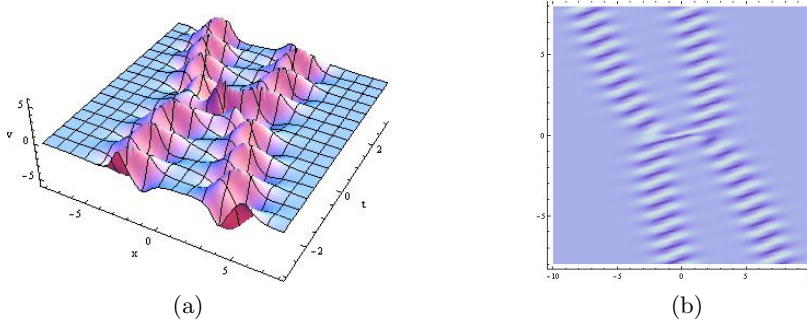

Figure 8: Shape and motion of the limit breather solution given by (5.1) with (5.26) and (5.28). (a). 3D-plot for $a_1 = b_1 = 1$, $k_1 = 0.8 + 0.5i$ and $\xi_1^{(0)} = 0$. (b). Density plot of (a) for $x \in [-10, 10]$, $t \in [-8, 8]$.

5.4 Dynamics of rational solutions

The first non-trivial rational solution to the mKdV equation is (4.21), i.e.,

$$v = v_0 - \frac{4v_0}{4v_0^2 X^2 + 1}, \quad X = x - 6v_0^2 t. \quad (5.29)$$

This is a non-singular traveling wave moving with the constant speed $6v_0^2$, constant amplitude $-3v_0$ and asymptotic line $v = v_0$. It is depicted in Fig.9.

The next rational solution is given by (4.22), i.e.,

$$v = v_0 - \frac{12v_0(X^4 + \frac{3}{2v_0^2}X^2 - \frac{3}{16v_0^4} - 24Xt)}{4v_0^2(X^3 + 12t - \frac{3X}{4v_0^2})^2 + 9(X^2 + \frac{1}{4v_0^2})^2}, \quad X = x - 6v_0^2 t. \quad (5.30)$$

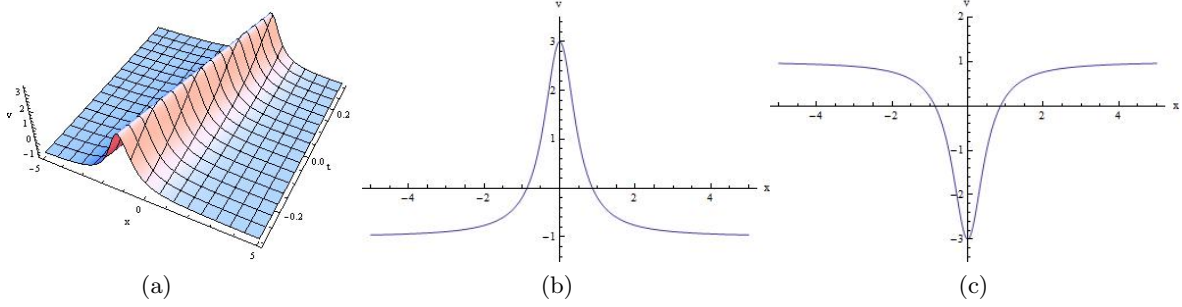

Figure 9: Shape and motion of the rational solution given by (5.29) for $v_0 = -0.8$ in (a), $v_0 = -1$ in (b) and $v_0 = 1$ in (c).

It can be viewed as a double-traveling wave solution

$$v = v_0 - \frac{12v_0(X^4 + \frac{3}{2v_0^2}XY - \frac{3}{16v_0^4})}{4v_0^2(X^3 - \frac{3Y}{4v_0^2})^2 + 9(X^2 + \frac{1}{4v_0^2})^2}, \quad (5.31)$$

with

$$X = x - 6v_0^2t, \quad Y = x - 22v_0^2t. \quad (5.32)$$

However, it does not show interactions of two single rational solutions. Only one wave is left for large x, t (see Fig.10). We re-depict Fig.10(a) in Fig.11 by a density plot so that we can see the wave top trace clearer.

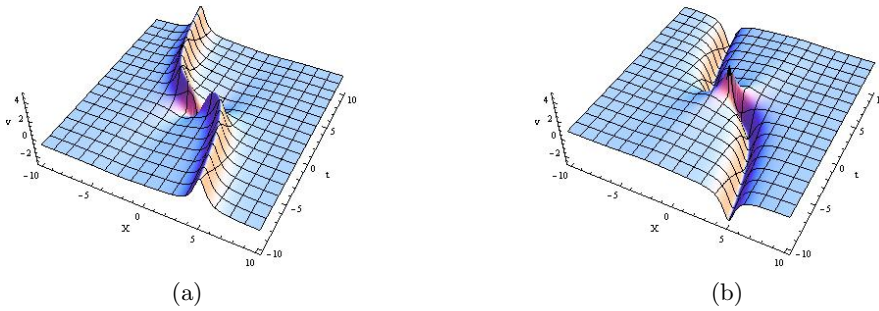

Figure 10: Shape and motion of the rational solution given by (5.30) for $v_0 = -0.8$ in (a) and $v_0 = 0.8$ in (b).

To realize the asymptotic behavior analytically, we rewrite the solution (5.30) in the following coordinates system

$$(X, T = X^3 + 12t + \frac{3}{16v_0^4}X) \quad (5.33)$$

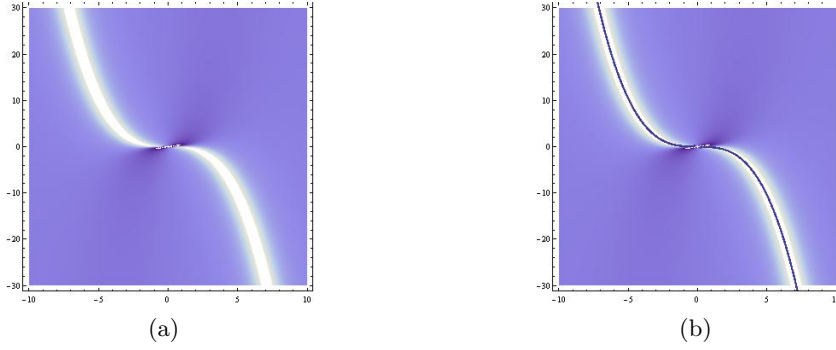

Figure 11: (a): Density plot of Fig.10 (a) with $X \in [-10, 10]$, $t \in [-30, 30]$. (b): (a) overlapped by the trajectory curve given by (5.36).

and this gives

$$v = v_0 - \frac{12v_0(3X^4 + \frac{3}{2v_0^2}X^2 - 2TX + \frac{3}{16v_0^4})}{4v_0^2(T - \frac{3}{16v_0^4X} - \frac{3X}{4v_0^2})^2 + 9(X^2 + \frac{1}{4v_0^2})^2}. \quad (5.34)$$

Then, by calculation it can be found that for given large X the wave (5.34) has a single stationary point at $T = 0$ where v gets a local extreme value

$$v = \frac{v_0(1 - 12v_0^2X^2)}{1 + 4v_0^2X^2}, \quad (5.35)$$

which goes to $-3v_0$ as $X \rightarrow \pm\infty$. Thus we can conclude that for large X, t the wave asymptotically travels along the curve

$$T = X^3 + 12t + \frac{3}{16v_0^4X} = 0 \quad (5.36)$$

with amplitude $-3v_0$. Fig.11(b) displays a density plot overlapped by the above wave trajectory curve.

More details on the rational solutions to the mKdV equation can be found in [40] where the rational solutions are derived via bilinear Bäcklund transformation.

6 Conclusions

6.1 Summation

In the paper we reviewed the Wronskian solutions to the mKdV equation (1.3) in terms of Wronskians. When a solution is expressed through the Wronskian

$$f = f(\varphi) = |\widehat{N - 1}|, \quad (6.1)$$

one needs to solve the finalized CES (2.18) together with (2.19), i.e.,

$$\varphi_{xx} = \mathbb{A}\varphi, \quad (6.2a)$$

$$\varphi_x = \mathbb{B}\bar{\varphi}, \quad (6.2b)$$

$$\varphi_t = -4\varphi_{xxx}, \quad (6.2c)$$

and

$$\mathbb{A} = \mathbb{B}\bar{\mathbb{B}}. \quad (6.3)$$

\mathbb{A} is the auxiliary matrix that we introduced to deal with the complex operation in (6.2b) and it works in practice. As a result, with the help of \mathbb{A} we solved the above CES and then categorized the solutions to the mKdV equation in terms of the canonical form of \mathbb{A} (rather than canonical form of \mathbb{B}). Solutions are categorized by solitons (together with their limit case) and breathers (together with their limit case). There are no rational solutions arising from (6.2) because no rational solutions correspond to zero eigenvalues of \mathbb{A} while we need $|\mathbb{B}| \neq 0$ to finish Wronskian verification. To derive rational solutions for the mKdV equation (1.3), we employed the Galilean transformed equation, i.e., the KdV-mKdV equation (1.4) which admits rational solutions in Wronskian form. Then the rational solutions to the mKdV equation can be recovered through the inverse transformation. Dynamics of some obtained solutions was analyzed and illustrated. Here, particularly, we would like to sum up a typical characteristic of limit solitons: the wave trajectories asymptotically follow logarithm curves (combined with linear functions). This point is based on several examples we have examined[43].

Obviously, through the Galilean transformation (4.2), all these obtained solutions of the mKdV equation (1.3) can easily be used for the KdV-mKdV equation (1.4) which often appears in physics contexts. In fact, in the paper we do not differ them from each other. In addition to the KdV-mKdV equation, our treatment to the complex operation in (6.2) can also be applied to the sine-Gordon equation.

There are Miura transformations between the KdV equation and the mKdV equation (for both $\varepsilon = \pm 1$). For the mKdV($\varepsilon = -1$) equation the Miura transformation provides a real map between solutions of the KdV equation and the mKdV equation($\varepsilon = -1$), c.f.[20]. However, when $\varepsilon = 1$, i.e., for the mKdV equation (1.3), the Miura transformation has to be complex. In more detail, it maps the real mKdV equation (1.3) to a complex KdV equation. That means we have had a nice determinant expression for the complex KdV equation. Further investigation about this will be considered separately.

6.2 List of solutions

Let us list out the obtained solutions and their corresponding basic Wronskian vectors. Solutions to the mKdV equation (1.3) can be given by

$$v = 2 \left(\arctan \frac{F_2}{F_1} \right)_x = \frac{-2(F_{1,x}F_2 - F_1F_{2,x})}{F_2^2 + F_1^2}, \quad (6.4a)$$

where

$$f = f(\varphi) = |\widehat{N-1}| = F_1 + iF_2, \quad F_1 = \text{Re}[f], \quad F_2 = \text{Im}[f]. \quad (6.4b)$$

The available Wronskian vectors are the following.

- **For soliton solutions:**

$$\varphi = \varphi_N^{[s]} = (\varphi_1, \varphi_2, \dots, \varphi_N)^T, \quad (6.5a)$$

with

$$\varphi_j = a_j^+ e^{\xi_j} + ia_j^- e^{-\xi_j}, \quad \xi_j = k_j x - 4k_j^3 t + \xi_j^{(0)}, \quad a_j^+, a_j^-, k_j, \xi_j^{(0)} \in \mathbb{R}. \quad (6.5b)$$

- **For limit solutions of solitons:**

$$\varphi = \varphi_N^{[ls]}(k_1) = \mathcal{A}^+ \mathcal{Q}_0^+ + i\mathcal{A}^- \mathcal{Q}_0^-, \quad \mathcal{A}^\pm \in \tilde{G}_N(\mathbb{R}), \quad (6.6a)$$

with

$$\mathcal{Q}_0^\pm = (\mathcal{Q}_{0,0}^\pm, \mathcal{Q}_{0,1}^\pm, \dots, \mathcal{Q}_{0,N-1}^\pm)^T, \quad \mathcal{Q}_{0,s}^\pm = \frac{1}{s!} \partial_{k_1}^s e^{\pm \xi_1}, \quad (6.6b)$$

where ξ_1 is defined in (6.5b).

- **For breather solutions:**

$$\varphi = \varphi_{2N}^{[b]} = (\varphi_{11}, \varphi_{12}, \varphi_{21}, \varphi_{22}, \dots, \varphi_{N1}, \varphi_{N2})^T, \quad (6.7a)$$

with

$$\varphi_{j1} = a_j e^{\xi_j} + b_j e^{-\xi_j}, \quad \varphi_{j2} = \bar{a}_j e^{\bar{\xi}_j} - \bar{b}_j e^{-\bar{\xi}_j}, \quad (6.7b)$$

$$\xi_j = k_j x - 4k_j^3 t + \xi_j^{(0)}, \quad a_j, b_j, \xi_j^{(0)} \in \mathbb{C}. \quad (6.7c)$$

- **For limit solutions of breathers:**

$$\varphi = \varphi_{2N}^{[lb]}(k_1) = (\varphi_{1,1}^+, \varphi_{1,2}^-, \varphi_{2,1}^+, \varphi_{2,2}^-, \dots, \varphi_{N,1}^+, \varphi_{N,2}^-)^T, \quad (6.8a)$$

and the elements are given through

$$\varphi^+ = (\varphi_{1,1}^+, \varphi_{2,1}^+, \dots, \varphi_{N,1}^+)^T = \mathcal{A} \mathcal{Q}_0^+ + \mathcal{B} \mathcal{Q}_0^-, \quad (6.8b)$$

$$\varphi^- = (\varphi_{1,2}^-, \varphi_{2,2}^-, \dots, \varphi_{N,2}^-)^T = \bar{\mathcal{A}} \bar{\mathcal{Q}}_0^+ - \bar{\mathcal{B}} \bar{\mathcal{Q}}_0^-, \quad (6.8c)$$

where $\mathcal{A}, \mathcal{B} \in \tilde{G}_N(\mathbb{C})$,

$$\mathcal{Q}_0^\pm = (\mathcal{Q}_{0,0}^\pm, \mathcal{Q}_{0,1}^\pm, \dots, \mathcal{Q}_{0,N-1}^\pm)^T, \quad \mathcal{Q}_{0,s}^\pm = \frac{1}{s!} \partial_{k_1}^s e^{\pm \xi_1}, \quad (6.8d)$$

and ξ_1 is defined in (6.7c).

We note that, thanks to the linear property of the CES (2.18), one may also get mixed solutions by arbitrarily combining the above vectors to be a new Wronskian vector. For example, take

$$\varphi = \begin{pmatrix} \varphi_{N_1}^{[s]} \\ \varphi_{N_2}^{[ls]}(k_{N_1+1}) \end{pmatrix}. \quad (6.9)$$

The related solution corresponds to the interaction between N_1 -soliton and a $(N_2 - 1)$ -order limit-soliton solutions.

Finally, for the rational solution, it is given by

$$v(x, t) = v_0 - \frac{2(F_{1,X} F_2 - F_1 F_{2,X})}{F_2^2 + F_1^2}, \quad X = x - 6v_0^2 t, \quad v_0 \neq 0 \in \mathbb{R}, \quad (6.10a)$$

where still

$$f = f(\psi) = |\widehat{N-1}| = F_1 + iF_2, \quad F_1 = \text{Re}[f], \quad F_2 = \text{Im}[f], \quad (6.10b)$$

and the Wronskian is composed by

$$\psi = (\psi_1, \psi_2, \dots, \psi_N)^T, \quad (6.11a)$$

with

$$\psi_{j+1} = \frac{1}{(2j)!} \frac{\partial^{2j}}{\partial k_1^{2j}} \varphi_1 \Big|_{k_1=0}, \quad (j = 0, 1, \dots, N-1), \quad (6.11b)$$

and

$$\varphi_1 = \sqrt{2v_0 + 2ik_1} e^{\eta_1} + \sqrt{2v_0 - 2ik_1} e^{-\eta_1}, \quad \eta_1 = k_1 X - 4k_1^3 t, \quad k_1 \in \mathbb{R}. \quad (6.11c)$$

Acknowledgments

The authors sincerely thank Prof. Gesztesy for kindly providing Refs.[20, 23]. This project is supported by the NSF of China (No. 11071157), Specialized Research Fund for the Doctoral Program of Higher Education of China (No. 20113108110002), Shanghai Leading Academic Discipline Project (No. J50101) and Postgraduate Innovation Foundation of Shanghai University (No. SHUCX111027).

A Proof of Theorem 1

Proof. The compatibility of (2.12a) and (2.12b), i.e., $\phi_{xt} = \phi_{tx}$, yields (2.13b). Using (2.12a) one gets the complex conjugate form of f as

$$\bar{f} = |\bar{B}(t)| | -1, \widehat{N-2} |. \quad (A.1)$$

Then the necessary derivatives of f and \bar{f} are presented as the following,

$$f_x = |\widehat{N-2}, N |, \quad (A.2a)$$

$$f_{xx} = |\widehat{N-3}, N-1, N | + |\widehat{N-2}, N+1 |, \quad (A.2b)$$

$$f_{xxx} = |\widehat{N-4}, N-2, N-1, N | + |\widehat{N-2}, N+2 | \\ + 2|\widehat{N-3}, N-1, N+1 |, \quad (A.2c)$$

$$f_t = -4(|\widehat{N-4}, N-2, N-1, N | - |\widehat{N-3}, N-1, N+1 | \\ + |\widehat{N-2}, N+2 |) + \text{tr}(C(t)) |\widehat{N-1} |, \quad (A.2d)$$

and

$$\bar{f}_x = |\bar{B}(t)| | -1, \widehat{N-3}, N-1 |, \quad (A.3a)$$

$$\bar{f}_{xx} = |\bar{B}(t)| (| -1, \widehat{N-4}, N-2, N-1 | + | -1, \widehat{N-3}, N |), \quad (A.3b)$$

$$\bar{f}_{xxx} = |\bar{B}(t)| (| -1, \widehat{N-3}, N+1 | + 2| -1, \widehat{N-4}, N-2, N | \\ + | -1, \widehat{N-5}, N-3, N-2, N-1 |), \quad (A.3c)$$

$$\bar{f}_t = -4|\bar{B}(t)| (| -1, \widehat{N-5}, N-3, N-2, N-1 | \\ - | -1, \widehat{N-4}, N-2, N | + | -1, \widehat{N-3}, N+1 |) \\ + |\bar{B}(t)|_t | -1, \widehat{N-2} | + \text{tr}(C(t)) |\bar{B}(t)| | -1, \widehat{N-2} |. \quad (A.3d)$$

Using the condition (2.12a) the complex conjugate of (A.2d) is

$$\begin{aligned}\bar{f}_t &= -4|\bar{B}(t)|(|-1, \widehat{N-5}, N-3, N-2, N-1| - |-1, \widehat{N-4}, N-2, N| \\ &\quad + |-1, \widehat{N-3}, N+1|) + \text{tr}(\bar{C}(t))|\bar{B}(t)||-1, \widehat{N-2}|,\end{aligned}$$

which should be same as (A.4). This requires $|B(t)|_t = 0$ and $\text{tr}(C(t)) \in \mathbb{R}(t)$, i.e., the condition (2.13a).

Noting that $\phi_{xx} = B(t)\bar{B}(t)\phi$ and using Proposition 1 with $\Omega_{j,s} = \partial_x^2$, we find

$$\begin{aligned}\text{tr}(B(t)\bar{B}(t))|-1, \widehat{N-3}, N-1| &= -|-1, \widehat{N-5}, N-3, N-2, N-1| \\ &\quad + |-1, \widehat{N-3}, N+1|,\end{aligned}\tag{A.4}$$

$$\text{tr}(B(t)\bar{B}(t))|\widehat{N-2}, N| = -|\widehat{N-4}, N-2, N-1, N| + |\widehat{N-2}, N+2|,\tag{A.5}$$

$$\text{tr}(B(t)\bar{B}(t))|-1, \widehat{N-2}| = -|-1, \widehat{N-4}, N-2, N-1| + |-1, \widehat{N-3}, N|,\tag{A.6}$$

$$\text{tr}(B(t)\bar{B}(t))|\widehat{N-1}| = -|\widehat{N-3}, N-1, N| + |\widehat{N-2}, N+1|.\tag{A.7}$$

Then, substituting (A.2) and (A.3) into (2.10a) and making use of (A.7), we have

$$\begin{aligned}&\bar{f}_t f - \bar{f} f_t + \bar{f}_{xxx} f - 3\bar{f}_{xx} f_x + 3\bar{f}_x f_{xx} - \bar{f} f_{xxx} \\ &= 6|\bar{B}(t)|(-|-1, \widehat{N-3}, N+1||\widehat{N-1}| - |-1, \widehat{N-4}, N-2, N-1||\widehat{N-2}, N| \\ &\quad + |\widehat{N-4}, N-2, N-1, N||-1, \widehat{N-2}| - |\widehat{N-3}, N-1, N+1||-1, \widehat{N-2}| \\ &\quad + |\widehat{N-2}, N+1||-1, \widehat{N-3}, N-1| - |-1, \widehat{N-4}, N-2, N||\widehat{N-1}|),\end{aligned}$$

which is zero in the light of Proposition 2. Similarly, one can prove (2.10b). Thus the proof is completed. \square

B Eigen-polynomial of $\mathbb{A} = \mathbb{B}\bar{\mathbb{B}}$

We prove the Proposition 3 through the following 2 Lemmas.

Lemma B.1. *For two arbitrary N th-order complex matrices A and B ,*

$$\det(\lambda I_N - AB) = \det(\lambda I_N - BA),\tag{B.1}$$

where I_N is the N th-order unit matrix.

Proof. Assuming that $\text{rank}(A) = r$, then there exist N th-order non-singular matrices P and Q such that

$$A = P \begin{pmatrix} I_r & 0 \\ 0 & 0 \end{pmatrix} Q.\tag{B.2}$$

Thus

$$\begin{aligned}\det(\lambda I_N - AB) &= \det(\lambda I_N - P \begin{pmatrix} I_r & 0 \\ 0 & 0 \end{pmatrix} QB) \\ &= \det(P^{-1}(\lambda I_N - P \begin{pmatrix} I_r & 0 \\ 0 & 0 \end{pmatrix} QB)P) \\ &= \det(\lambda I_N - P^{-1}(P \begin{pmatrix} I_r & 0 \\ 0 & 0 \end{pmatrix} QB)P) \\ &= \det(\lambda I_N - \begin{pmatrix} I_r & 0 \\ 0 & 0 \end{pmatrix} QBP).\end{aligned}$$

In a similar way we have

$$\det(\lambda I_N - BA) = \det(\lambda I_N - QBP \begin{pmatrix} I_r & 0 \\ 0 & 0 \end{pmatrix}). \quad (\text{B.3})$$

If we rewrite the matrix QBP into the following block matrix form with same structure as $\begin{pmatrix} I_r & 0 \\ 0 & 0 \end{pmatrix}$,

$$QBP = \begin{pmatrix} B_{11} & B_{12} \\ B_{21} & B_{22} \end{pmatrix}, \quad (\text{B.4})$$

then we have

$$\begin{pmatrix} I_r & 0 \\ 0 & 0 \end{pmatrix} QBP = \begin{pmatrix} B_{11} & B_{12} \\ 0 & 0 \end{pmatrix}, \quad QBP \begin{pmatrix} I_r & 0 \\ 0 & 0 \end{pmatrix} = \begin{pmatrix} B_{11} & 0 \\ B_{21} & 0 \end{pmatrix}, \quad (\text{B.5})$$

which further means

$$\det(\lambda I_N - AB) = \lambda^{N-r} \det(\lambda I_r - B_{11}) = \det(\lambda I_N - BA). \quad (\text{B.6})$$

We complete the proof. \square

Lemma B.2. *Assuming that B is an arbitrary N th-order complex matrix and \bar{B} is its complex conjugate, then $\det(\lambda I - \bar{B}B)$ is a polynomial of λ with real coefficients.*

Proof. Write

$$f(\lambda) = \det(\lambda I_N - \bar{B}B) = a_N \lambda^N + \cdots + a_1 \lambda + a_0. \quad (\text{B.7})$$

Then using Lemma B.1 with $A = \bar{B}$ we have

$$f(\lambda) = \det(\lambda I_N - \bar{B}B) = \det(\lambda I_N - B\bar{B}) = \overline{\det(\bar{\lambda} I_N - \bar{B}B)} = \overline{f(\bar{\lambda})}, \quad (\text{B.8})$$

which means all the coefficients $\{a_j\}$ are real. \square

C Discussions on the trivial solutions to the CES (2.18)

Let the square matrices \mathbb{A}, \mathbb{B} follow the relation

$$\mathbb{A} = \mathbb{B}\bar{\mathbb{B}}. \quad (\text{C.1})$$

We start from the 2×2 case. Noting that the product of all the eigenvalues of \mathbb{A} is non-negative, in the following we first look at

$$\mathbb{A} = \begin{pmatrix} -k_1^2 & 0 \\ 0 & -k_2^2 \end{pmatrix}, \quad k_1 \neq k_2 \neq 0, \quad k_1, k_2 \in \mathbb{R}, \quad (\text{C.2})$$

and suppose

$$\mathbb{B} = \begin{pmatrix} a & b \\ c & d \end{pmatrix} \quad (\text{C.3})$$

with undetermined $a, b, c, d \in \mathbb{C}$. However, in this case it can be found that the matrix relation (C.1) does not have any solutions unless $k_1^2 = k_2^2$. So next we turn to consider

$$\mathbb{A} = \begin{pmatrix} -k^2 & 0 \\ 0 & -k^2 \end{pmatrix}, \quad k \in \mathbb{R}. \quad (\text{C.4})$$

In this case, the equation (C.1) admits a non-diagonal matrix solution \mathbb{B} as

$$\mathbb{B} = \begin{pmatrix} -d & -\frac{d^2+k^2}{c} \\ c & d \end{pmatrix} e^{i\theta}, \quad c \neq 0, \quad c, d, \theta \in \mathbb{R}. \quad (\text{C.5})$$

We note that such a \mathbb{B} does not lead to any nontrivial solutions to the mKdV equation. In fact, in the CES (2.18), the general solution to the equation set (2.18a) and (2.18c) is

$$\varphi = \begin{pmatrix} \varphi_1 \\ \varphi_2 \end{pmatrix} = H \begin{pmatrix} e^{i\xi} \\ e^{-i\xi} \end{pmatrix} \quad (\text{C.6a})$$

with arbitrary matrix $H \in \mathbb{C}_{2 \times 2}$ and

$$\xi = kx + 4k^3t + \xi^{(0)}, \quad k, \xi^{(0)} \in \mathbb{R}. \quad (\text{C.6b})$$

However, no matter what condition the matrix H should satisfy under the equation (2.18b), the Wronskian

$$f(\varphi) = |H| f((e^{i\xi}, e^{-i\xi})^T)$$

is always a constant, which leads to a trivial solution to the mKdV equation. In the case of the $N \times N$ matrix (N is even)

$$A = \text{diag}(-k^2, -k^2, \dots, -k^2), \quad k \in \mathbb{R},$$

similar to (C.6), the general solution to (2.18a) and (2.18c) is

$$\phi = H \times (e^{i\xi}, e^{-i\xi}, 0, 0, \dots, 0)^T, \quad H \in \mathbb{C}_{N \times N},$$

which leads to a zero Wronskian $f(\varphi)$.

With these discussions we can conclude that for the CES (2.18) with an $N \times N$ matrix

$$\mathbb{A} = \text{diag}(\alpha, \alpha, \dots, \alpha), \quad \alpha \in \mathbb{R}, \quad (\text{C.7})$$

the possible solution φ to (2.18) composes a trivial Wronskian $f(\varphi)$.

D Proof for Theorem 2

Proof. The parameter v_0 will lead to complicated expressions for \bar{f} and its derivatives. For simplification let us introduce the notation $|\cdot|_j$ where the subscript j indicates the absence of the $\phi^{(j)}$ column[22], for example,

$$|\widehat{N}|_j = |\phi^{(0)}, \dots, \phi^{(j-1)}, \phi^{(j+1)}, \dots, \phi^{(N)}|.$$

Derivatives of f have already given in (A.2). For \bar{f} , using the CES (4.6) we can reach

$$\begin{aligned}
\bar{f} &= |B^{-1}(t)| \sum_{j=0}^N (-v_0)^j i^{N-j} |\widehat{N}|_j, \\
\bar{f}_X &= |B^{-1}(t)| \left(\sum_{j=0}^{N-1} (-v_0)^{j+1} i^{N-j-1} |\widehat{N}|_j + \sum_{j=0}^{N-1} (-v_0)^j i^{N-j} |\widehat{N-1, N+1}|_j \right), \\
\bar{f}_{XX} &= |B^{-1}(t)| \left((-v_0)^N |\widehat{N-2, N+1}| + \sum_{j=0}^{N-1} (-v_0)^j i^{N-j} |\widehat{N-1, N+2}|_j \right. \\
&\quad + \sum_{j=0}^{N-2} (-v_0)^j i^{N-j} |\widehat{N-2, N, N+1}|_j + \sum_{j=0}^{N-2} (-v_0)^{j+2} i^{N-j-2} |\widehat{N}|_j \\
&\quad \left. + 2 \sum_{j=0}^{N-2} (-v_0)^{j+1} i^{N-j-1} |\widehat{N-1, N+1}|_j \right), \\
\bar{f}_{XXX} &= |B^{-1}(t)| \left(3 \sum_{j=0}^{N-3} (-v_0)^{j+2} i^{N-j-2} |\widehat{N-1, N+1}|_j + (-v_0)^N |\widehat{N-2, N+2}| \right. \\
&\quad + 3 \sum_{j=0}^{N-2} (-v_0)^{j+1} i^{N-j-1} |\widehat{N-1, N+2}|_j + 2(-v_0)^N |\widehat{N-3, N-1, N+1}| \\
&\quad + \sum_{j=0}^{N-1} (-v_0)^j i^{N-j} |\widehat{N-1, N+3}|_j + 2 \sum_{j=0}^{N-2} (-v_0)^j i^{N-j} |\widehat{N-2, N, N+2}|_j \\
&\quad + 3 \sum_{j=0}^{N-3} (-v_0)^{j+1} i^{N-j-1} |\widehat{N-2, N, N+1}|_j + 2(-v_0)^{N-1} i |\widehat{N-3, N, N+1}| \\
&\quad \left. + \sum_{j=0}^{N-3} (-v_0)^j i^{N-j} |\widehat{N-3, N-1, N, N+1}|_j + \sum_{j=0}^{N-3} (-v_0)^{j+3} i^{N-j-3} |\widehat{N}|_j \right), \\
\bar{f}_t &= -4 |B^{-1}(t)| \left(\sum_{j=0}^{N-1} (-v_0)^j i^{N-j} |\widehat{N-1, N+3}|_j + \sum_{j=0}^{N-3} (-v_0)^{j+3} i^{N-j-3} |\widehat{N}|_j \right. \\
&\quad + \sum_{j=0}^{N-3} (-v_0)^j i^{N-j} |\widehat{N-3, N-1, N, N+1}|_j + (-v_0)^N |\widehat{N-2, N+2}| \\
&\quad - \sum_{j=0}^{N-2} (-v_0)^j i^{N-j} |\widehat{N-2, N, N+2}|_j - (-v_0)^{N-1} i |\widehat{N-3, N, N+1}| \\
&\quad \left. - (-v_0)^N |\widehat{N-3, N-1, N+1}| \right) + \text{tr}(C(t)) |B^{-1}(t)| \sum_{j=0}^N (-v_0)^j i^{N-j} |\widehat{N}|_j.
\end{aligned}$$

Using the condition (4.6) the complex conjugate of (A.2d) should be same as the above \bar{f}_t . This requires $\text{tr}(C(t)) \in \mathbb{R}(t)$, i.e., the condition (4.7b).

Besides, noting that $\phi_{XX} = (B(t)\bar{B}(t) - v_0^2 I_N)\phi$ and using Proposition 1 with $\Omega_{j,s} = \partial_X^2$, we can have the following identities:

$$\begin{aligned} \text{tr}(B(t)\bar{B}(t) - v_0^2 I_N)|\widehat{N}|_j &= |\widehat{N-1}, N+2|_j - |\widehat{N-2}, N, N+1|_j \\ &\quad - |\widehat{N}|_{j-2}, \quad (j = 0, 1, \dots, N-2), \\ \text{tr}(B(t)\bar{B}(t) - v_0^2 I_N)|\widehat{N-1}, N+1|_j &= |\widehat{N-1}, N+3|_j - |\widehat{N-3}, N-1, N, N+1|_j \\ &\quad - |\widehat{N-1}, N+1|_{j-2}, \quad (j = 0, 1, \dots, N-3), \\ \text{tr}(B(t)\bar{B}(t) - v_0^2 I_N)|\widehat{N-1}| &= -|\widehat{N-3}, N-1, N| + |\widehat{N-2}, N+1|, \\ \text{tr}(B(t)\bar{B}(t) - v_0^2 I_N)|\widehat{N-2}, N| &= -|\widehat{N-4}, N-2, N-1, N| + |\widehat{N-2}, N+2|. \end{aligned}$$

With these results and (A.2) in hand, for (4.4a) we have

$$\begin{aligned} &\bar{f}_t f - \bar{f} f_t + \bar{f}_{XX} f - 3\bar{f}_{XX} f_X + 3\bar{f}_X f_{XX} - \bar{f} f_{XXX} \\ &= 6(-v_0)^{N-1} i (|\widehat{N-3}, N, N+1| |\widehat{N-1}| - |\widehat{N-2}, N| |\widehat{N-3}, N-1, N+1| \\ &\quad + |\widehat{N-2}, N+1| |\widehat{N-3}, N-1, N|) \\ &= 0. \end{aligned}$$

Similarly, one can prove (4.4b). □

References

- [1] D.J. Zhang, Notes on solutions in Wronskian form to soliton equations: Korteweg de Vries-type, arXiv:nlin.SI/0603008.
- [2] R.M. Miura, C.S. Gardner and M.D. Kruskal, KdV equation and generalizations. II. Existence of conservation laws and constant of motion, *J. Math. Phys.* **9** (1968) 1204–1209.
- [3] C.S. Gardner, J.M. Green, M.D. Kruskal and R.M. Miura, Method for solving the Korteweg-de Vries equation, *Phys. Rev. Lett.* **19** (1967) 1095–1097.
- [4] H. Ono, Soliton fission in anharmonic lattices with reflectionless inhomogeneity, *J. Phys. Soc. Jpn.* **61** (1992) 4336–4343.
- [5] T. Kakutani and H. Ono, Weak non-linear hydromagnetic waves in a cold collision-free plasma, *J. Phys. Soc. Jpn.* **26** (1969) 1305–1318.
- [6] K. Konno and Y.H. Ichikawa, A modified Korteweg de Vries equation for ion acoustic waves, *J. Phys. Soc. Jpn.* **37** (1974) 1631–1636.
- [7] S. Watanabe, Ion acoustic soliton in plasma with negative ion, *J. Phys. Soc. Jpn.* **53** (1984) 950–956.
- [8] K.E. Lonngren, Ion acoustic soliton experiment in a plasma, *Opt. Quant. Electron.* **30** (1998) 615–630.

- [9] T.S. Komatsu and S.-i. Sasa, Kink soliton characterizing traffic congestion, *Phys. Rev. E* **52** (1995) 5574–5582.
- [10] T. Nagatani, TDGL and mKdV equations for jamming transition in the lattice models of traffic, *Physica A* **264** (1999) 581–592.
- [11] V. Ziegler, J. Dinkel, C. Setzer and K.E. Lonngren, On the propagation of nonlinear solitary waves in a distributed Schottky barrier diode transmission line, *Chaos, Solitons and Fractals* **12** (2001) 1719–1728.
- [12] B. Cushman-Roisin, L.J. Pratt and E.A. Ralph, A general theory for equivalent barotropic thin jets, *J. Phys. Oceanogr.* **23** (1992) 91–103.
- [13] E.A. Ralph and L. Pratt, Predicting eddy detachment for an equivalent barotropic thin jet, *J. Nonlinear Sci.* **4** (1994) 355–374.
- [14] R. Grimshaw, E. Pelinovsky, T. Talipova and A. Kurkin, Simulation of the transformation of internal solitary waves on oceanic shelves, *J. Phys. Oceanogr.* **34** (2004) 2774–2779.
- [15] R. Grimshaw, Internal solitary waves, in *Environmental Stratified Flows*, ed. R. Grimshaw (Kluwer Academic, Boston, 2001), pp. 1–27.
- [16] F.D. Tappert and C.M. Varma, Asymptotic theory of self-trapping of heat pulses in solids, *Phys. Rev. Lett.* **25** (1970) 1108–1111.
- [17] R. Hirota, Exact solution of the modified Korteweg-de Vries equation for multiple collisions of solitons, *J. Phys. Soc. Jpn.* **33** (1972) 1456–1458.
- [18] M. Wadati, The modified Korteweg-de Vries equation, *J. Phys. Soc. Jpn.* **34** (1973) 1289–1296.
- [19] S. Tanaka, Modified Korteweg-de Vries equation and scattering theory, *Proc. Jap. Acad.* **48** (1972) 466–469.
- [20] T. Gesztesy, W. Schweiger and B. Simon, Commutation methods applied to the mKdV-equation, *Trans. Amer. Math. Soc.* **324** (1991) 465–525.
- [21] J. Satsuma, A Wronskian representation of N -soliton solutions of nonlinear evolution equations, *J. Phys. Soc. Jpn.* **46** (1979) 359–360.
- [22] J.J.C. Nimmo and N.C. Freeman, The use of Bäcklund transformations in obtaining N -soliton solutions in Wronskian form, *J. Phys. A: Math. Gen.* **17** (1984) 1415–1424.
- [23] T. Gesztesy and W. Schweiger, Rational KP and mKP-solutions in Wronskian form, *Rep. Math. Phys.* **30** (1991) 205–222.
- [24] N. C. Freeman and J. J. C. Nimmo, Soliton solutions of the KdV and KP equations: the Wronskian technique, *Phys. Lett. A* **95** (1983) 1–3.
- [25] S. Sirianunpiboon, S.D. Howard and S.K. Roy, A note on the Wronskian form of solutions of the KdV equation, *Phys. Lett. A* **134** (1988) 31–33.

- [26] W.X. Ma and Y.C. You, Solving the Korteweg-de Vries equation by its bilinear form: Wronskian solutions, *Trans. Amer. Math. Soc.* **357** (2005) 1753–1778.
- [27] J. Zhou, D.J. Zhang and S.L. Zhao, Breathers and limit solutions of the nonlinear lumped self-dual network equation, *Phys. Lett. A* **373** (2009) 3248–3258.
- [28] D.J. Zhang, J.B. Zhang and Q. Shen, A limit symmetry of the KdV equation and its applications, *Theore. Math. Phys.* **163** (2010) 634–643.
- [29] X. Kou, D.J. Zhang, Y. Shi and S.L. Zhao, Generating solutions to discrete sine-Gordon equation from modified Bäcklund transformation, *Commun. Theor. Phys.* **55** (2011) 545–550.
- [30] D.J. Zhang, J. Hietarinta, Generalized double-Wronskian solutions to the nonlinear Schrödinger equation, preprint, (2005).
- [31] R. Hirota, Exact solution of the KdV equation for multiple collisions of solitons. *Phys. Rev. Lett.* **27** (1971) 1192–1194.
- [32] R. Hirota, *The Direct Method In Soliton Theory* (Cambridge University Press, Cambridge, 2004).
- [33] E. Kamke, *Handbook on Ordinary Differential Equations* (in Chinese) (Science Press, Beijing, 1977).
- [34] D.J. Zhang, The N -soliton solutions for the modified KdV equation with self-consistent sources, *J. Phys. Soc. Jpn.* **71** (2002) 2649–2656.
- [35] H. Ono, Algebraic soliton of the modified Korteweg-de Vries equation, *J. Phys. Soc. Jpn.* **41** (1976) 1817–1818.
- [36] M.J. Ablowitz and J. Satsuma, Solitons and rational solutions of nonlinear evolution equations, *J. Math. Phys.* **19** (1978) 2180–2186.
- [37] M.J. Ablowitz and H. Segur, *Solitons and the Inverse Scattering Transform* (SIAM, Philadelphia, 1981).
- [38] M. Wadati, Wave propagation in nonlinear lattice I, *J. Phys. Soc. Jpn.* **38** (1975) 673–680.
- [39] R. Hirota and J. Satsuma, A variety of nonlinear network equations generated from the Bäcklund transformation for the Toda lattice, *Suppl. Prog. Theor. Phys.* **59** (1976) 64–100.
- [40] Y.Y. Sun and D.J. Zhang, Rational solutions with non-zero asymptotics of the modified Korteweg-de Vries equation, to appear in *Commun. Theor. Phys.* (2012).
- [41] J.J.C. Nimmo and N.C. Freeman, Rational solutions of the KdV equation in Wronskian form, *Phys. Lett. A* **96** (1983) 443–446.
- [42] H. Wu and D.J. Zhang, Mixed rational-soliton solutions of two differential-difference equations in Casorati determinant form, *J. Phys. A: Gen. Math.* **36** (2003) 4867–4873.
- [43] D.J. Zhang, Limit solutions for soliton equations: Straight way and limit interpretation, preprint, (2010).