

# Quantum transport through single phenalenyl molecule: Effect of interface structure

Santanu K. Maiti<sup>1,2,\*</sup>

<sup>1</sup>*Theoretical Condensed Matter Physics Division, Saha Institute of Nuclear Physics,  
1/AF, Bidhannagar, Kolkata-700 064, India*

<sup>2</sup>*Department of Physics, Narasinha Dutt College, 129, Belilious Road, Howrah-711 101, India*

## Abstract

Electronic transport characteristics through a single phenalenyl molecule sandwiched between two metallic electrodes are investigated by the use of Green's function technique. A parametric approach, based on the tight-binding model, is used to study the transport characteristics through such molecular bridge system. The electronic transport properties are significantly influenced by (a) the molecule-to-electrode interface structure and (b) the molecule-to-electrode coupling strength.

**PACS No.:** 73.23.-b; 73.63.Rt; 85.65.+h

**Keywords:** Phenalenyl molecule; Conductance;  $I$ - $V$  characteristic.

\***Corresponding Author:** Santanu K. Maiti  
Electronic mail: santanu.maiti@saha.ac.in

# 1 Introduction

Molecular transport have attracted much more attention since molecules constitute promising building blocks for future generation of electronic devices. Electron transport through molecules was first studied theoretically in 1974 by Aviram *et al.* [1]. Since then numerous experiments [2, 3, 4, 5, 6] have been performed through molecules placed between two electrodes with few nanometer separation. The operation of such two-terminal devices is due to an applied bias. Current passing across the junction is strongly nonlinear function of the applied bias voltage and its detailed description is a very complex problem. The complete knowledge of the conduction mechanism in this scale is not well understood even today. The transport properties of these systems are associated with some quantum effects, like as quantization of energy levels, quantum interference of electron waves [7, 8, 9, 10, 11, 12, 13, 14], etc. Following experimental developments, theory can play a major role in understanding the new mechanisms of conductance. The single-molecule electronics plays a key role in the design of future nanoelectronic circuits, but, the goal of developing a reliable molecular-electronics technology is still over the horizon and many key problems, such as device stability, reproducibility and the control of single-molecule transport need to be solved. It is very essential to control electron conduction through such quantum devices and the present understanding about it is quite limited. For example, it is not very clear how the molecular transport is affected by the structure of the molecule itself or by the nature of its coupling to the electrodes. To design molecular electronic devices with specific properties, structure-conductance relationships are needed and in a recent work Ernzerhof *et al.* [15] have presented a general design principle and performed several model calculations to demonstrate the concept.

There exist several *ab initio* methods for the calculation of conductance [16, 17, 18, 19, 20, 21, 22] through a molecular bridge system. At the same time the tight-binding model has been extensively studied in the literature and it has also been extended to DFT transport calculations [23]. The study of static density functional theory (DFT) [24] within the local-density approximation (LDA) to investigate the electronic transport through nanoscale conductors, like atomic-scale point contacts, has met with nice success. But, when this similar theory applies to molecular junctions, theoretical conduc-

tances achieve larger values compared to the experimental predictions and these quantitative discrepancies need extensive study in this particular field. In a recent work, Sai *et al.* [25] have predicted a correction to the conductance using the time-dependent current-density functional theory since the dynamical effects give significant contribution in the electron transport, and illustrated some important results with specific examples. Similar dynamical effects have also been reported in some other recent papers [26, 27], where authors have abandoned the infinite reservoirs, as originally introduced by Landauer, and considered two large but finite oppositely charged electrodes connected by a nanojunction.

Our aim of the present article is to reproduce an analytic approach based on the tight-binding model to characterize the electronic transport properties for the model of a single phenalenyl molecule and focus our attention on the effects of (a) the molecule-to-electrode coupling strength and (b) the quantum interferences in these transport. This is an interesting molecular system to study because of the unique behavior of the phenalenyl molecule and contacting the molecule to the electrodes from two different locations several interesting results are obtained for the electron transport. Here we adopt a simple parametric approach [28, 29, 30, 31, 32, 33] for this calculation. The parametric study is motivated by the fact that the *ab initio* theories are computationally very expensive and here we concentrate only on the qualitative effects rather than the quantitative ones. This is why we restrict our calculations only on the simple analytical formulation of the transport problem. Not only that, the *ab initio* theories do not give any new qualitative behavior for this particular study in which we concentrate ourselves.

This paper is specifically arranged as follows. In Section 2, we give a very brief description for the calculation of transmission probability ( $T$ ), conductance ( $g$ ) and current ( $I$ ) through a finite size conductor sandwiched between two metallic electrodes. Section 3 focuses the behavior of the conductance-energy and the current-voltage characteristics for the single phenalenyl molecule and studies the effects of (a) the molecule-to-electrode interface structure and (b) the molecular coupling strength on the above mentioned characteristics. These two factors i.e., the interface structure and the coupling strength play significant role on the quantum transport through molecular devices. Finally, we summarize our results in Section 4.

## 2 A glimpse onto the theoretical formulation

Here we describe very briefly about the methodology for the calculation of transmission probability ( $T$ ), conductance ( $g$ ) and current ( $I$ ) through a finite size conducting system attached to two semi-infinite metallic electrodes by using the Green's function technique.

Let us first consider a one-dimensional conductor with  $N$  number of atomic sites (array of filled circles) connected to two semi-infinite metallic electrodes, namely, source and drain, as given in Fig. 1. The conducting system in between the two elec-

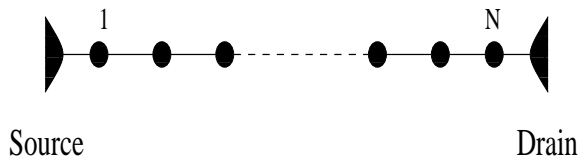

Figure 1: Schematic view of a one-dimensional conductor with  $N$  number of atomic sites (filled circles) attached to two electrodes, source and drain, through sites 1 and  $N$ , respectively.

trodes can be an array of few quantum dots, or a single molecule, or an array of few molecules, etc. At low voltages and temperatures, the conductance of the conductor can be written by using the Landauer conductance formula [34, 35],

$$g = \frac{2e^2}{h} T \quad (1)$$

where  $g$  is the conductance and  $T$  is the transmission probability of an electron through the conductor. The transmission probability can be expressed in terms of the Green's function of the conductor and the coupling of the conductor to the two electrodes by the expression [34, 35],

$$T = \text{Tr} [\Gamma_S G_C^r \Gamma_D G_C^a] \quad (2)$$

where  $G_C^r$  and  $G_C^a$  are respectively the retarded and advanced Green's function of the conductor.  $\Gamma_S$  and  $\Gamma_D$  are the coupling terms due to the coupling of the conductor to the source and drain, respectively. For the complete system i.e., the conductor including the two electrodes, the Green's function is defined as,

$$G = (\epsilon - H)^{-1} \quad (3)$$

where  $\epsilon = E + i\eta$ .  $E$  is the injecting energy of the source electron and  $\eta$  gives an infinitesimal imaginary part to  $\epsilon$ . Evaluation of this Green's function

requires the inversion of an infinite matrix as the system consists of the finite conductor and the two semi-infinite electrodes. However, the entire system can be partitioned into sub-matrices corresponding to the individual sub-systems, and the Green's function for the conductor can be effectively written as,

$$G_C = (\epsilon - H_C - \Sigma_S - \Sigma_D)^{-1} \quad (4)$$

where  $H_C$  is the Hamiltonian for the conductor sandwiched between the two electrodes. The single band tight-binding Hamiltonian for the conductor within the non-interacting picture can be written in the form,

$$H_C = \sum_i \epsilon_i c_i^\dagger c_i + \sum_{\langle ij \rangle} t (c_i^\dagger c_j + c_j^\dagger c_i) \quad (5)$$

where  $c_i^\dagger$  ( $c_i$ ) is the creation (annihilation) operator of an electron at site  $i$ ,  $\epsilon_i$ 's are the site energies and  $t$  is the nearest-neighbor hopping integral. In Eq. 4,  $\Sigma_S = h_{SC}^\dagger g_S h_{SC}$  and  $\Sigma_D = h_{DC} g_D h_{DC}^\dagger$  are the self-energy operators due to the two electrodes, where  $g_S$  and  $g_D$  are respectively the Green's function for the source and the drain.  $h_{SC}$  and  $h_{DC}$  are the coupling matrices and they will be non-zero only for the adjacent points in the conductor, 1 and  $N$  as shown in Fig. 1, and the electrodes respectively. The coupling terms  $\Gamma_S$  and  $\Gamma_D$  for the conductor can be calculated through the expression,

$$\Gamma_{\{S,D\}} = i \left[ \Sigma_{\{S,D\}}^r - \Sigma_{\{S,D\}}^a \right] \quad (6)$$

where  $\Sigma_{\{S,D\}}^r$  and  $\Sigma_{\{S,D\}}^a$  are the retarded and advanced self-energies, respectively, and they are conjugate with each other. Datta *et al.* [34] have shown that the self-energies can be expressed like as,

$$\Sigma_{\{S,D\}}^r = \Lambda_{\{S,D\}} - i\Delta_{\{S,D\}} \quad (7)$$

where  $\Lambda_{\{S,D\}}$  are the real parts of the self-energies which correspond to the shift of the energy eigenvalues of the conductor and the imaginary parts  $\Delta_{\{S,D\}}$  of the self-energies represent the broadening of these energy levels. This broadening is much larger than the thermal broadening and this is why we restrict our all calculations in this article only at absolute zero temperature. The real and imaginary parts of the self-energies can be determined in terms of the hopping integral ( $\tau_{\{S,D\}}$ ) between the boundary site of the conductor and the electrodes, the injection energy ( $E$ ) of the transmitting electron and the hopping strength ( $v$ ) between nearest-neighbor sites of the electrodes.

Thus the coupling terms  $\Gamma_S$  and  $\Gamma_D$  can be written in terms of the retarded self-energy as,

$$\Gamma_{\{S,D\}} = -2\text{Im} \left[ \Sigma_{\{S,D\}}^r \right] \quad (8)$$

Now all the information regarding the conductor to electrodes coupling are included into the two self energies as stated above and are analyzed through the use of Newns-Anderson chemisorption theory [28, 29]. The detailed description of this theory is obtained in these two references.

Hence, by calculating the self-energies, the coupling terms  $\Gamma_S$  and  $\Gamma_D$  can be easily obtained and then the transmission probability ( $T$ ) will be computed from the expression as mentioned in Eq. 2.

Since the coupling matrices  $h_{SC}$  and  $h_{DC}$  are non-zero only for the adjacent points in the conductor, 1 and  $N$  as shown in Fig. 1, the transmission probability becomes,

$$T(E, V) = 4\Delta_{11}^S(E, V)\Delta_{NN}^D(E, V)|G_{1N}(E, V)|^2 \quad (9)$$

where  $\Delta_{11} = \langle 1|\Delta|1 \rangle$ ,  $\Delta_{NN} = \langle N|\Delta|N \rangle$  and  $G_{1N} = \langle 1|G_C|N \rangle$ .

The current passing through the conductor is depicted as a single-electron scattering process between the two reservoirs of charge carriers. The current-voltage relation is evaluated from the following expression [35],

$$I(V) = \frac{e}{\pi\hbar} \int_{E_F - eV/2}^{E_F + eV/2} T(E, V) dE \quad (10)$$

where  $E_F$  is the equilibrium Fermi energy. For the sake of simplicity, here we assume that the entire voltage is dropped across the conductor-electrode interfaces and this assumption does not greatly change the qualitative behaviors of the  $I$ - $V$  characteristics. This assumption is based on the fact that the electric field inside the molecule, especially for short molecules, seems to have a minimal effect on the conductance-voltage characteristics. On the other hand for quite longer molecules and high bias voltage, the electric field inside the molecule may play a more significant role depending on the internal structure of the molecule [34], yet the effect is too small. Using the expression of  $T(E, V)$  as in Eq. 9 the final form of  $I(V)$  will be,

$$I(V) = \frac{4e}{\pi\hbar} \int_{E_F - eV/2}^{E_F + eV/2} \Delta_{11}^S(E, V)\Delta_{NN}^D(E, V) \times |G_{1N}(E, V)|^2 dE \quad (11)$$

Eqs. 1, 9 and 11 are the final working formulæ for the calculation of conductance  $g$ , transmission probability  $T$ , and current  $I$ , respectively through any finite size conductor sandwiched between two electrodes.

By using the above methodology, in this article we will investigate the electronic transport characteristics through a single phenalenyl molecule (Fig. 2). Throughout this article we set  $E_F = 0$  and choose the unit  $c = e = h = 1$ .

### 3 Results and their interpretation

In this section we focus on the conductance-energy and current-voltage characteristics of a single phenalenyl molecule and investigate the dependence of these characteristics on (a) the molecule-to-electrode interface structure and (b) the molecular coupling strength. The schematic representations of single phenalenyl molecules attached to the two metallic electrodes are shown in Fig. 2. To

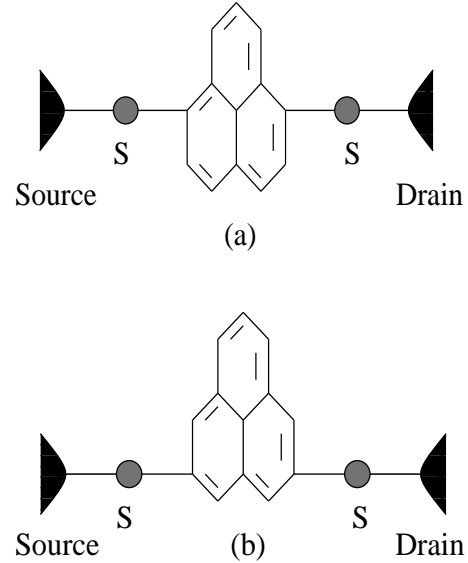

Figure 2: Schematic view of single phenalenyl molecules attached to two metallic electrodes, namely, source and drain, through thiol (S-H) groups.

characterize the molecule-to-electrode interface effect, here we consider two different geometries (see Figs. 2(a) and (b)). These single molecules are connected to the electrodes by thiol (S-H) groups. In experiments, two electrodes made from gold (Au) are used and molecules attached to the electrodes

by thiol (S-H) groups in the chemisorption technique where hydrogen (H) atoms remove and sulfur (S) atoms reside. Here the molecule is described by the similar tight-binding Hamiltonian as prescribed in Eq. 5. Throughout the article we describe all the essential features of electron transport in two distinct regimes. One is  $\tau_{\{S,D\}} \ll t$ , called the weak-

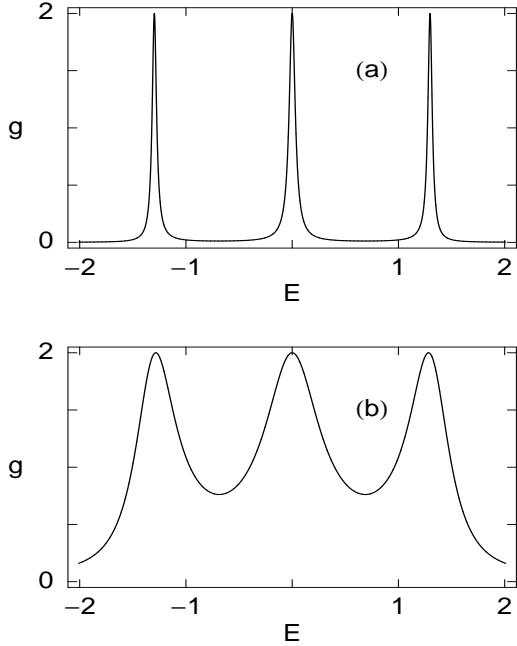

Figure 3: Conductance  $g$  as a function of the energy  $E$  for the phenalenyl molecule connected to the electrodes according to Fig. 2(a). (a) and (b) correspond to the results for the weak and strong molecule-to-electrode coupling limits, respectively.

coupling limit and the other one is  $\tau_{\{S,D\}} \sim t$ , called the strong-coupling limit, where  $\tau_S$  and  $\tau_D$  are the hopping strengths of the molecule to the source and drain, respectively. The common set of values of the parameters used in our calculations for these two limiting cases are:  $\tau_S = \tau_D = 0.5$ ,  $t = 2.5$  (weak-coupling) and  $\tau_S = \tau_D = 1.5$ ,  $t = 2.5$  (strong-coupling). We set the nearest-neighbor hopping strength  $v = 4$ .

Figure 3 shows the variation of the conductance  $g$  as a function of the injecting electron energy  $E$  for the molecular bridge given in Fig. 2(a). Figure 3(a) corresponds to the result for the bridge system in the weak coupling limit. The conductance is almost everywhere zero, except at the resonances where it approaches to 2. The resonant peaks in the conductance spectrum coincide with the energy eigen-

values of the single phenalenyl molecule. Therefore the conductance spectrum manifests itself the electronic structure of the molecule. On the other hand, in the strong coupling limit the resonant peaks get substantial widths, as shown in Fig. 3(b) and it emphasizes that the electron conduction takes place throughout the energy range (the range taken here in the figure). This is due to the broadening of the

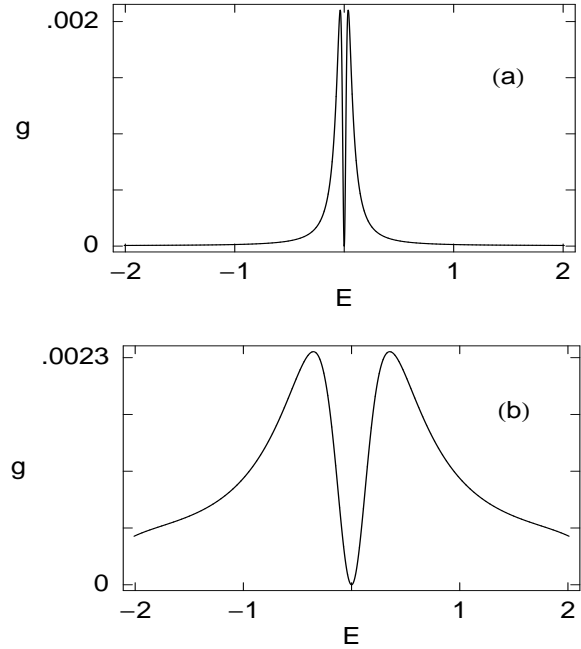

Figure 4: Conductance  $g$  as a function of the energy  $E$  for the phenalenyl molecule connected to the electrodes according to Fig. 2(b). (a) and (b) correspond to the results for the weak and strong molecule-to-electrode coupling limits, respectively.

molecular energy levels in the strong coupling case, where the contribution comes from the imaginary parts of the self-energies [34], as described earlier.

To characterize the molecule-to-electrode interface effect on electron transport, we plot the conductance in Fig. 4 for the molecular bridge given in Fig. 2(b). Figures 4(a) and (b) correspond to the results for the bridge system in the weak and strong coupling limits, respectively. The broadening of the conductance peaks in the strong coupling limit (see Fig. 4(b)) is due to the same reason as mentioned earlier. From the curves plotted in Fig. 4, we see that the conductance peaks do not reach to unity anymore and get much reduced value, compared to the results described in Fig. 3. Such a behavior can be understood as follows. The electrons are car-

ried from the source to drain through the molecule and thus the electron waves propagating along the two arms of the molecular ring may suffer a phase shift between themselves, according to the result of quantum interference between the various pathways that the electron can take. Therefore, the probability amplitude of the electron across the molecular ring becomes strengthened or weakened (from the standard interpretation of the wave functions). It emphasizes itself especially as transmittance cancellations and anti-resonances in the transmission (conductance) spectrum. Here the mentioned phase shift is observed by the variation of the geometry of the molecular bridge. The most significant issue for considering these two different molecular bridge systems is that in this way the interference conditions are changed quite significantly.

Another key feature observed from the conductance spectrum is the existence of the conductance (transmittance) zero. From Fig. 4, it is observed that the conductance zero appears across  $E = 0$ . Such anti-resonant state is specific to the interferometric nature of the scattering and does not occur in usual one-dimensional scattering problems of potential barriers. It is also observed that the position of the anti-resonant state on the energy scale is independent of the molecule-to-electrode coupling strength. The width of this state is very small and hence it does not give any significant contribution to the current-voltage characteristics. However, the variations of the interference conditions have strong influence on the magnitude of the current flowing through the bridge systems.

Thus it can be emphasized that the electron transmission is strongly influenced by the molecule-to-electrode interface structure.

The scenario of electron transfer through the molecular junction is much more clearly visible from the current-voltage characteristics. Current through the molecular system is computed by the integration procedure (given in Eq. 11) [35] of the transmission function  $T$ . The behavior of the transmission function is similar to that of the conductance variation since  $g = 2T$  (from the Landauer conductance formula, Eq. 1, with  $e = h = 1$  in our present formulation). In Fig. 5, we plot the current-voltage characteristics for the molecular bridge shown in Fig. 2(a). Figures 5(a) and (b) correspond to the currents for the bridge system in the weak and strong coupling cases, respectively. It is observed that in the weak coupling case the current shows staircase-like structure with sharp steps. This is due to the discreteness of molecu-

lar resonances as shown in Fig. 3(a). As the voltage increases, the electrochemical potentials on the electrodes are shifted and eventually cross one of the molecular energy levels. Accordingly, a current channel is opened up and a jump in the  $I$ - $V$  curve appears. The shape and height of these current steps depend on the width of the molecular resonances. With the increase of the molecule-to-electrode coupling strength, the current varies continuously with the applied bias voltage and gains much more bigger values, as shown in Fig. 5(b). This behavior can be clearly observed by noting the area under the curve of the conductance spectrum given in Fig. 3(b). Comparing the results plotted

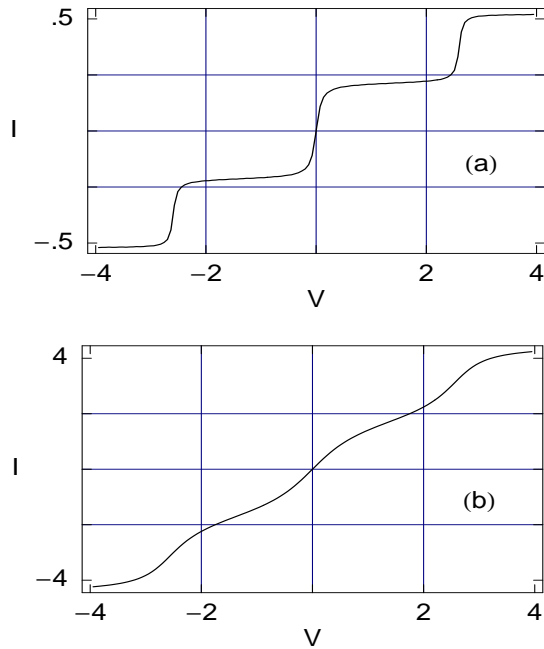

Figure 5: Current  $I$  as a function of the applied bias voltage  $V$  for the phenalenyl molecule connected to the electrodes according to Fig. 2(a). (a) and (b) correspond to the results for the weak and strong molecule-to-electrode coupling limits, respectively.

in Figs. 5(a) and (b) it is clearly observed that the current amplitude gets an order of magnitude enhancement with the increase of the molecular coupling strength. So the electron transport through the molecular bridge is significantly affected by the molecule-to-electrode coupling strength.

The effect of the molecule-to-electrode interface structure on the electron transport through the phenalenyl molecule is much more clearly explained from Fig. 6, where we plot the currents for the



molecular bridge given in Fig. 2(b). Figures 6(a) and (b) correspond to the currents in the two limiting cases as in Fig. 5. Similar to the previous case, here also the current amplitude gets an order of magnitude enhancement with the increase of the molecular coupling strength. But the significant ob-

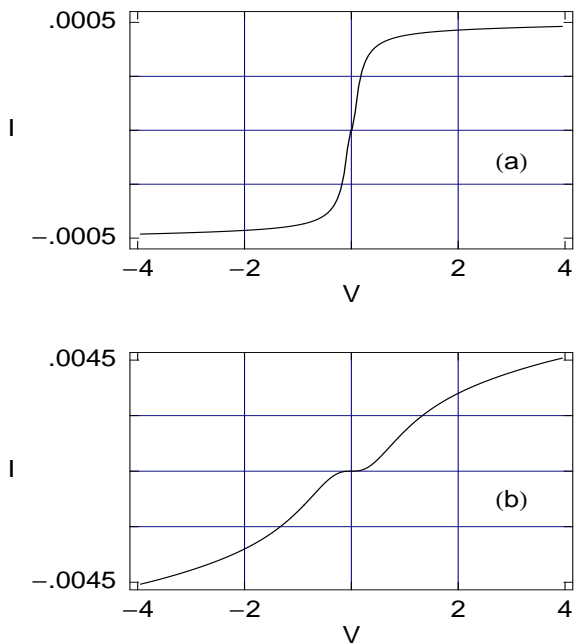

Figure 6: Current  $I$  as a function of the applied bias voltage  $V$  for the phenalenyl molecule connected to the electrodes according to Fig. 2(b). (a) and (b) correspond to the results for the weak and strong molecule-to-electrode coupling limits, respectively.

servation is that for this bridge (Fig. 2(b)) the current amplitudes get reduced enormously compared to the results predicted for the molecular bridge given in Fig. 2(a) (see the results given in Fig. 5). This is solely due to the quantum interference effect between the different pathways that the electron can take. So it can be emphasized that designing a molecular device is strongly influenced by the molecule-to-electrode interface structure.

All the above mentioned characteristics are also valid if the electron-electron interaction is taken into account. The main effect of the electron correlation is to shift and to split the resonant positions. This is due to the fact that the on-site Coulomb repulsive energy  $U$  gives a renormalization of the site energies. Depending on the strength of the nearest-neighbor hopping integral ( $t$ ) compared to the on-site Coulomb interaction ( $U$ ) different regimes ap-

pear. For the case  $t/U \ll 1$ , the resonances and anti-resonances would split into two distinct narrow bands separated by the on-site Coulomb energy. On the other hand, for the case where  $t/U \gg 1$ , the resonances and anti-resonances would occur in pairs.

## 4 Concluding remarks

To summarize, a parametric approach based on the tight-binding model has been used to investigate the electronic transport characteristics of a single phenalenyl molecule sandwiched between two metallic electrodes. Here we have used the Green's function method to determine the transmission probability ( $T$ ), the conductance ( $g$ ) and the current-voltage ( $I$ - $V$ ) characteristics through the molecule. This technique can be used to study the electronic transport in any complicated molecular bridge system. This is an interesting molecular system to study because of the unique behavior of the phenalenyl molecule. In this article, contacting the phenalenyl molecule from two different locations leads to a large change in magnitude and shape in the transmission spectrum and the associated current-voltage curves. Electron conduction through the molecule is strongly influenced by (a) the molecule-to-electrode coupling strength and (b) the interface structure. These findings indicate that designing a whole system that includes not only molecule but also molecule-to-electrode coupling and interface structure are highly important in fabricating molecular electronic devices.

More studies are expected to take the Schottky effect, comes from the charge transfer across the metal-molecule interfaces, the static Stark effect, which is taken into account for the modification of the electronic structure of the molecular bridge due to the applied bias voltage (essential especially for higher voltages). Here we have also ignored the effects of inelastic scattering processes and electron-electron correlation to characterize the electron transport through such molecular bridge systems.

## References

- [1] A. Aviram and M. Ratner, *Chem. Phys. Lett.* **29**, 277 (1974).
- [2] R. M. Metzger *et al.*, *J. Am. Chem. Soc.* **119**, 10455 (1997).

- [3] C. M. Fischer, M. Burghard, S. Roth, and K. V. Klitzing, *Appl. Phys. Lett.* **66**, 3331 (1995).
- [4] J. Chen, M. A. Reed, A. M. Rawlett, and J. M. Tour, *Science* **286**, 1550 (1999).
- [5] M. A. Reed, C. Zhou, C. J. Muller, T. P. Burgin, and J. M. Tour, *Science* **278**, 252 (1997).
- [6] T. Dadosh, Y. Gordin, R. Krahne, I. Khivrich, D. Mahalu, V. Frydman, J. Sperling, A. Yacoby, and I. Bar-Joseph, *Nature* **436**, 677 (2005).
- [7] K. Tagami, M. Tsukada, T. Matsumoto, and T. Kawai, *Phys. Rev. B* **67**, 245324 (2003).
- [8] M. Magoga and C. Joachim, *Phys. Rev. B* **59**, 16011 (1999).
- [9] J.-P. Launay and C. D. Coudret, in: A. Aviram and M. A. Ratner (Eds.), *Molecular Electronics*, New York Academy of Sciences, New York (1998).
- [10] R. Baer and D. Neuhauser, *Chem. Phys.* **281**, 353 (2002).
- [11] R. Baer and D. Neuhauser, *J. Am. Chem. Soc.* **124**, 4200 (2002).
- [12] D. Walter, D. Neuhauser, and R. Baer, *Chem. Phys.* **299**, 139 (2004).
- [13] R. H. Goldsmith, M. R. Wasielewski, and M. A. Ratner, *J. Phys. Chem. B* **110**, 20258 (2006).
- [14] M. Ernzerhof, H. Bahmann, F. Goyer, M. Zhuang, and P. Rocheleau, *J. Chem. Theory Comput.* **2**, 1291 (2006).
- [15] M. Ernzerhof, M. Zhuang, and P. Rocheleau, *J. Chem. Phys.* **123**, 134704 (2005).
- [16] K. Tagami, L. Wang, and M. Tsukada, *Nano Lett.* **4** (2004) 209.
- [17] S. N. Yaliraki, A. E. Roitberg, C. Gonzalez, V. Mujica, and M. A. Ratner, *J. Chem. Phys.* **111**, 6997 (1999).
- [18] M. Di Ventra, S. T. Pantelides, and N. D. Lang, *Phys. Rev. Lett.* **84**, 979 (2000).
- [19] Y. Xue, S. Datta, and M. A. Ratner, *J. Chem. Phys.* **115**, 4292 (2001).
- [20] J. Taylor, H. Gou, and J. Wang, *Phys. Rev. B* **63**, 245407 (2001).
- [21] P. A. Derosa and J. M. Seminario, *J. Phys. Chem. B* **105**, 471 (2001).
- [22] P. S. Damle, A. W. Ghosh, and S. Datta, *Phys. Rev. B* **64**, R201403 (2001).
- [23] (a) M. Elstner *et al.*, *Phys. Rev. B* **58**, 7260 (1998). (b) T. Frauenheim *et al.*, *J. Phys.: Condens. Matter* **14**, 3015 (2002).
- [24] (a) P. Hohenberg and W. Kohn, *Phys. Rev.* **136**, B864 (1964). (b) W. Kohn and L. J. Sham, *Phys. Rev.* **140**, A1133 (1965).
- [25] N. Sai, M. Zwolak, G. Vignale, and M. D. Ventra, *Phys. Rev. Lett.* **94**, 186810 (2005).
- [26] N. Bushong, N. Sai, and M. D. Ventra, *Nano Lett.* **5**, 2569 (2005).
- [27] M. D. Ventra and T. N. Todorov, *J. Phys.: Condens. Matter* **16**, 8025 (2004).
- [28] V. Mujica, M. Kemp, and M. A. Ratner, *J. Chem. Phys.* **101**, 6849 (1994).
- [29] V. Mujica, M. Kemp, A. E. Roitberg, and M. A. Ratner, *J. Chem. Phys.* **104**, 7296 (1996).
- [30] M. P. Samanta, W. Tian, S. Datta, J. I. Henderson, and C. P. Kubiak, *Phys. Rev. B* **53**, R7626 (1996).
- [31] M. Hjort and S. Staftröm, *Phys. Rev. B* **62**, 5245 (2000).
- [32] K. Walczak, *Cent. Eur. J. Chem.* **2**, 524 (2004).
- [33] K. Walczak, *Phys. Stat. Sol. (b)* **241**, 2555 (2004).
- [34] W. Tian, S. Datta, S. Hong, R. Reifenberger, J. I. Henderson, and C. I. Kubiak, *J. Chem. Phys.* **109**, 2874 (1998).
- [35] S. Datta, *Electronic transport in mesoscopic systems*, Cambridge University Press, Cambridge (1997).