

October, 2005

## Tunnel transport through multiple junctions

J. Peralta-Ramos<sup>a,\*</sup> and A. M. Llois<sup>a</sup>

<sup>a</sup> *Departamento de Física, Centro Atómico Constituyentes, Comisión Nacional de Energía Atómica*

We calculate the conductance through double junctions of the type M(inf.)-Sn-Mm-Sn-M(inf.) and triple junctions of the type M(inf.)-Sn-Mm-Sn-Mm-Sn-M(inf.), where M(inf.) are semi-infinite metallic electrodes, Sn are 'n' layers of semiconductor and Mm are 'm' layers of metal (the same as the electrodes), and compare the results with the conductance through simple junctions of the type M(inf.)-Sn-M(inf.). The junctions are bi-dimensional and their parts (electrodes and 'active region') are periodic in the direction perpendicular to the transport direction. To calculate the conductance we use the Green's Functions Landauer-Büttiker formalism. The electronic structure of the junction is modeled by a tight binding Hamiltonian. For a simple junction we find that the conductance decays exponentially with semiconductor thickness. For double and triple junctions, the conductance oscillates with the metal in-between thickness, and presents peaks for which the conductance is enhanced by 1-4 orders of magnitude. We find that when there is a conductance peak, the conductance is higher to that corresponding to a simple junction. The maximum ratio between the conductance of a double junction and the conductance of a simple junction is 146 %, while for a triple junction it is 323 %. These oscillations in the conductance are explained in terms of the energy spectrum of the junction's active region.

KEY WORDS: tunnel conductance, multiple tunnel junctions.

\* Corresponding author

Centro Atómico Constituyentes, Av. Gral. Paz 1499, San Martín (1650), Buenos Aires,  
Argentina

TEL: (54-11) 6772-7007 FAX: (54-11) 6772-7121

peralta@cnea.gov.ar

A magnetic tunnel junction (MTJ) consists of a few layers of a non-conducting material placed between two ferromagnetic electrodes. If we apply a voltage to the electrodes, a current will flow through the junction. It is observed experimentally that the magnitude of this current depends on the relative orientation of the magnetization in each electrode. This phenomenon is termed tunneling magnetoresistance (TMR), and is nowadays being extensively studied since it forms the basis of what is called 'spintronics'.

Simple MTJ's like that described above have been extensively studied [1], but double and triple junctions, in which metallic layers are inserted between the non-conducting material, have not. Some recent conductance measurements in double junctions [2,3] show a large increase in the conductance as compared to the conductance of simple junctions composed of the same materials, indicating that multiple junctions may present an advantage over simple ones. The aim of this contribution is to study, within a very simple model for the junction's electronic structure, what happens with the conductance of a simple junction when we insert metallic layers in between the semiconductor.

As a model system, we consider a semiconductor whose structure is given by a square Bravais lattice of constant  $a = 3.2 \text{ \AA}$  with two atoms per unit cell, A and B. Each semiconductor layer consists of an infinite array of atoms A and B in the  $y$  direction, and has a thickness of  $3.2 \text{ \AA}$ , as shown in Fig. 1. In a simple junction, the semiconductor slab is sandwiched by two semi-infinite metallic electrodes of the same structure which are paramagnetic, composed of atoms C and D instead of A and B. Epitaxial growth of the spacer on the metallic leads is assumed. The electronic structure of the junction is modeled by a tight-binding Hamiltonian with one  $s$  orbital per site and second nearest neighbors interaction. For the semiconductor, the on-site energies are  $E_A = 1 \text{ eV}$  and  $E_B = 1.5 \text{ eV}$ , and the hopping parameter is  $t = 0.2 \text{ eV}$  for first and second nearest-neighbors. With these parameters, a band gap of  $0.5 \text{ eV}$  is obtained. For the electrodes, the parameters are  $E_C = 2.8 \text{ eV}$ ,  $E_D = 2.9 \text{ eV}$  and  $t = 1 \text{ eV}$ . The Fermi energy  $E_F$  falls in the middle of the spacer's band gap. To construct double and triple junctions, metallic layers identical to the electrodes are inserted in between the semiconductor layers of a simple junction. Fig. 2 shows schematically the structure of simple, double and triple junctions. The active region consists of a 'semiconductor region' and in-between metallic layers.

The conductance is calculated using the Landauer-Büttiker formalism [4] expressed in terms of the active region's Green's function  $G_S = [\hat{1}E - H_S - \Sigma_L - \Sigma_R]^{-1}$ , where  $\hat{1}$  stands for the unit matrix,  $H_S$  is the Hamiltonian corresponding to the active part of the junction, and  $\Sigma_{L/R}$  are the self-energies describing the interaction of the active region with the left (L) or right (R) electrodes. In this expression,  $E$  is actually  $E + i\eta$ , where

$\eta > 0$  is a very small real number. This Green's function describes the propagation of an electron through the active region **taking into account, via the self-energies, the presence of the electrodes**. The self-energies are given by  $\Sigma_L = H_{LS}^\dagger g_L H_{LS}$  and  $\Sigma_R = H_{RS}^\dagger g_R H_{RS}$ , where  $H_{LS}$  and  $H_{RS}$  describe the coupling of the active region with the electrodes, and  $g_{L/R}$  are the surface Green's functions for each electrode. These surface Green's functions are calculated using a semi-analytical method [5] and are exact within our tight-binding approximation. The transmission probability  $T$  is given by [4]  $T(k_y, E) = Tr [\Delta_L G_S \Delta_R G_S^\dagger]$  where  $\Delta_{L/R} = i(\Sigma_{L/R} - \Sigma_{L/R}^\dagger)$ , while the conductance is given by

$$\Gamma(E) = \frac{2e^2}{h} \frac{1}{N_{k_y}} \sum_{k_y} T(k_y, E) \quad (1)$$

where the 2 comes from spin degeneracy and  $N_{k_y}$  is the total number of wave vectors considered (in our case 400 is enough to achieve stable values of  $\Gamma$ ). In this work we restrict to  $E = E_F$ .

For a simple junction, it is found that the conductance decays exponentially with semiconductor thickness, with a decay parameter in excellent agreement with its complex band structure [6,7]. For double and triple junctions, the conductance presents peaks for certain thicknesses of the in-between metal, in which the conductance raises by 1 to 4 orders of magnitude with respect to other thicknesses. The peak conductance is more than one order of magnitude larger for a multiple junction as compared to the conductance of a simple junction, and this conductance is higher for triple than for double junctions. Fig. 3 shows as an example the conductance of a double junction of 2 semiconductor layers as a function of the number of layers of the metal in between.

It is found that for 2, 6 and 9 layers of the metal in between there are peaks in the conductance. The ratio between the maximum conductance of a double or triple junction and the conductance of a simple junction is shown in Fig. 4. It is seen that the maximum ratio is 146 % for a double junction and 323 % for a triple junction, which represent very large increases in the conductance of these multiple junctions. For a double junction, the largest increase occurs for 3 semiconductor layers at each side of the metal layers, while for a triple junction it occurs for 4 semiconductor layers. Lastly, for those in-between metal thicknesses for which there is a conductance peak, it is found that the energy spectrum of the junction's active region possesses an eigenenergy very close to the Fermi energy of the electrodes, and that this does not happen for other in-between metal thicknesses. As confirmed by density of states calculations, the insertion of metal layers in between the semiconductor results in the appearance of electronic states with energies in the semiconductor's band gap. By calculating partial densities of states projected onto each active region's atom, it is found that these states are not localized, and, to the contrary, extend throughout the whole active region. For certain thicknesses of the in-between metallic layers, some of these band gap states have an energy very close to  $E_F$ , thus producing a resonance state which extends throughout the whole junction, including the electrodes.

In conclusion, by using a very simple model junction we have made plausible a situation in which the conductance of a simple junction largely increases by the insertion of metal in between the non-conducting material, and have also shown that this effect is to be traced back to resonance states that can extend throughout the whole junction. We be-

lieve that by making the electrodes ferromagnetic, the conductance peaks for each spin channel will occur at different thicknesses of the in-between metal, thus allowing to tune the values of TMR (the ratio between the conductance in the parallel and antiparallel configuration) by varying this thickness. These issues are currently being investigated. This work was partially funded by UBACyT-X115, Fundación Antorchas and PICT 03-10698. Ana María Llois belongs to CONICET (Argentina).

### References

- [1] X-G Zhang *et al*, J. Phys.: Condens. Matter **15** (2003) R1603-R1639
- [2] J. H. Lee *et al*, J. Magn. Magn. Mater. **286** (2005), 138-141
- [3] T. Nozaki *et al*, Appl. Phys. Lett. **86**, 082501 (2005)
- [4] S. Datta, 'Electronic transport in mesoscopic systems', Cambridge University Press, United Kingdom, 1999
- [5] S. Sanvito *et al*, Phys. Rev. B **59**, 11936 (1999)
- [6] Ph. Mavropoulos *et al*, Phys. Rev. Lett. **85** (2000) 1088
- [7] Jerónimo Peralta-Ramos *et al*, Physica B **354** (2004) 166-170

Figure 1

Structure of the semiconductor. The system is periodic in the  $y$  direction. The electrodes are semi-infinite in the  $x$  direction and have the same structure as the semiconductor.

Figure 2

Schematic structure of a simple, double and triple junction.

Figure 3

Conductance at the Fermi energy as a function of the number of layers of the in-between metal, for a double junction with 2 semiconductor layers at each side of the in-between metal.

Figure 4

Ratio between the largest conductances obtained for double and triple junctions and that of the simple junction, as a function of the number of layers in the semiconducting regions.

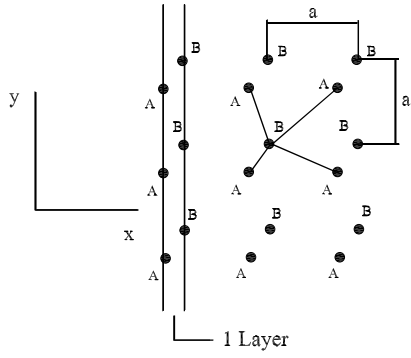

Figure 1:

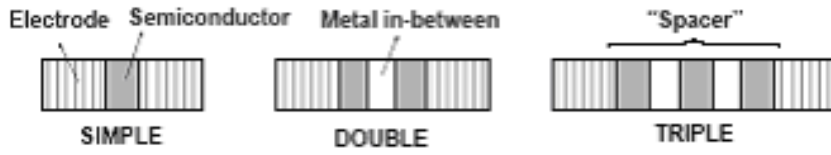

Figure 2:



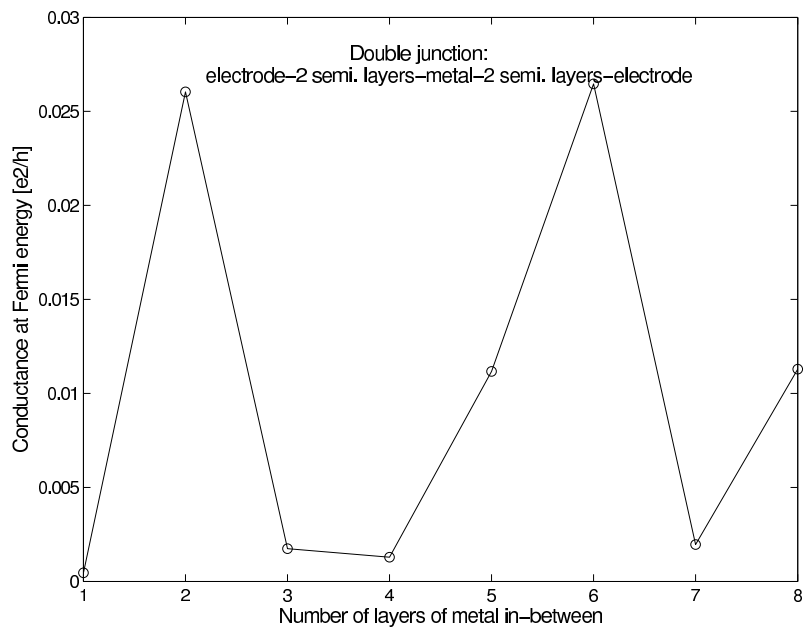

Figure 3:

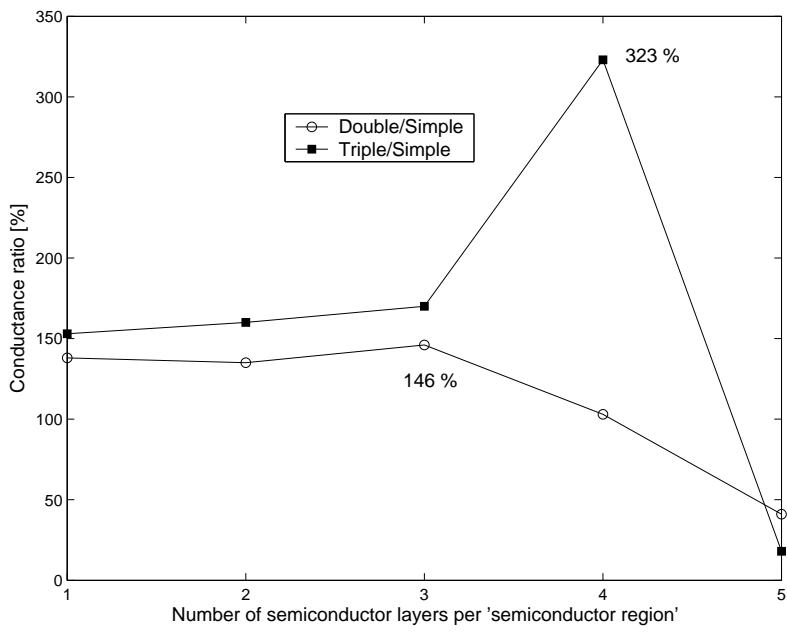

Figure 4: